



## N/D468

### N/DYM® Dynamic Supercardioid Instrument Microphone

- Designed specifically for musical instruments
- Accurate response, even in high sound pressure level (SPL) applications
- Flexible mechanical design for optimum positioning
- Supercardioid pattern for exceptional acoustic isolation and feedback rejection

---

#### Description

The Electro-Voice N/D468, part of a new generation of N/DYM® microphones, is specifically designed to accurately capture the sound of horns, acoustic and electric guitars, and the percussive energy of drums in both live performance and studio recording. The N/D468 is a member of a family of microphones manufactured to enhance sonic smoothness, improve gain-before-feedback, and provide more consistent performance with greater durability than earlier generations of N/DYM® microphones. EV's microphone designers created a smooth, extended response with an open "top end" to reproduce instrumental sounds with natural acoustic accuracy. The N/D468's reduced size and exclusive pivoting yoke gives you maximum mechanical versatility on any instrument. The N/D468 is the musician's choice for a microphone with unsurpassed mechanical flexibility and studio-quality acoustics.

Characteristic of all N/DYM® microphones is the outstanding neodymium-iron-boron magnetic structure. This structure provides greater sensitivity for exceptional signal-to-noise ratio and improved recording quality. Combining the N/DYM® mag-

netic structure with a large, reinforced diaphragm results in a transducer manifesting a warm, open and transparent sound quality normally found in studio-quality microphones. The N/D468 also includes a highly effective hum-bucking coil that reduces hum interference from lighting and other electrical power sources.

N/DYM® microphones feature EV's AcoustiDYM™ shock-mount system. This unique vibration isolating system works as a multistage device. At low frequencies, a rear sound wave cancels the diaphragm motion while, at high frequencies, the specially designed rubber shock mount isolates the transducer from motion. Combined with the windscreen bumper, the shock mount forms an advanced technology, vibration isolating system that dramatically reduces all forms of handling noise for the most demanding situations.

To ensure superior gain-before-feedback in live performance and acoustic isolation in recording studio environments, the N/D468 is constructed with a supercardioid polar pattern. The supercardioid pattern yields greater rejection and acoustic isolation to off-axis sounds than the typical heart-shaped cardioid pattern. For enhanced clarity, the polar re-

sponse is also unusually uniform with frequency. The impact of the supercardioid polar design is to reduce the likelihood of feedback in live performance conditions, particularly with typical monitor speaker placements.

The N/D468 pop filter's unique design utilizes a specially processed Acoustifoam™ filter to minimize wind noise and vocal P-pops. This design makes the pop filter an integral part of the microphone's removable front grille assembly, allowing easy cleaning for continued top performance.

---

#### Operation

The N/D468's low-frequency response varies with the distance of the sound source to the microphone. This is known as "proximity effect." Maximum bass response is produced in "close-up" use with the microphone 1/4 inch from the sound source. Minimal bass response is experienced at distances greater than 24 inches. By working closer to the microphone, the instrument will sound more robust. The pivoting yoke designed for the N/D468 allows this type of versatile microphone placement.

"Close miking" will also reduce the potential for feedback from a PA sound system.

# N/D468 Supercardioid Instrument Microphone

This benefit is in addition to the feedback-reducing supercardioid polar pattern. When close-talked, the substantial bass boost provides an increase in overall microphone output level. The mixer gain may be proportionately reduced, resulting in a reduction of the system's sensitivity to feedback caused by sound entering the microphone from the loudspeakers.

The dynamic element of the N/D468 will provide reliable operation in extreme temperature, humidity and other adverse conditions that would render typical condenser microphones useless. These N/D468 features will provide years of trouble-free operation.

## Certified Performance

Every N/D468 is inspected by a quality control tester and subjected to a computer-controlled test system that verifies numerous performance parameters. After the performance meets or exceeds our rigorous standards, the actual measured frequency response is plotted on a "Certificate of Performance" and included with the microphone. Certified performance may vary from published "Average Response." This certificate guarantees that each N/D468 will perform to exacting standards of the **100% quality assurance testing**, established by EV's design engineers.

## Limited Warranty

Electro-Voice products are guaranteed against malfunction due to defects in materials or workmanship for a specified period, as noted in the individual product-line statement(s) below, or in the individual prod-

uct data sheet or owner's manual, beginning with the date of original purchase. If such malfunction occurs during the specified period, the product will be repaired or replaced (at our option) without charge. The product will be returned to the customer prepaid.

**Exclusions and Limitations:** The Limited Warranty does not apply to: (a) exterior finish or appearance; (b) certain specific items described in the individual product-line statement(s) below, or in the individual product data sheet or owner's manual; (c) malfunction resulting from use or operation of the product other than as specified in the product data sheet or owner's manual; (d) malfunction resulting from misuse or abuse of the product; or (e) malfunction occurring at any time after repairs have been made to the product by anyone other than EVI Audio Service or any of its authorized service representatives. **Obtaining Warranty Service:** To obtain warranty service, a customer must deliver the product, prepaid, to EVI Audio Service or any of its authorized service representatives together with proof of purchase of the product in the form of a bill of sale or receipted invoice. A list of authorized service representatives is available from EVI Audio Service at 600 Cecil Street, Buchanan, MI 49107 (800/685-2606 or FAX 616/695-4743). **Incidental and Consequential Damages Excluded:** Product repair or replacement and return to the customer are the only remedies provided to the customer. Electro-Voice shall not be liable for any incidental or consequential damages including, without limitation, injury to per-

sons or property or loss of use. Some states do not allow the exclusion or limitation of incidental or consequential damages so the above limitation or exclusion may not apply to you. **Other Rights:** This warranty gives you specific legal rights, and you may also have other rights which vary from state to state.

**Electro-Voice Wired Microphones** are guaranteed against malfunction from any cause for two (2) years from the date of original purchase. In addition, the Limited Warranty for the acoustic system contained in these microphones shall apply for the life of the product, defined as a period of ten (10) years from the date that the manufacture of the specific microphone has been discontinued. Any and all active electronics incorporated in these microphones are guaranteed against malfunction due to defects in materials or workmanship for a period of three (3) years from the date of original purchase. The Limited Warranty does not extend to cables, cable connectors, or switches. Additional details are included in the Uniform Limited Warranty statement.

**For technical assistance**, contact Technical Support at 800/234-6831 or 616/695-6831, M-F, 8:00 a.m. to 5:00 p.m. Eastern Standard time.

Specifications subject to change without notice.

# N/D468 Supercardioid Instrument Microphone

N/D468 Supercardioid Instrument Microphone

**Figure 1—Frequency Response**

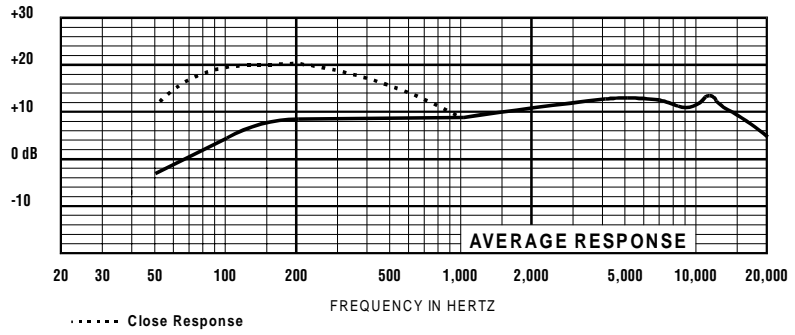

**Figure 2—Polar Response**

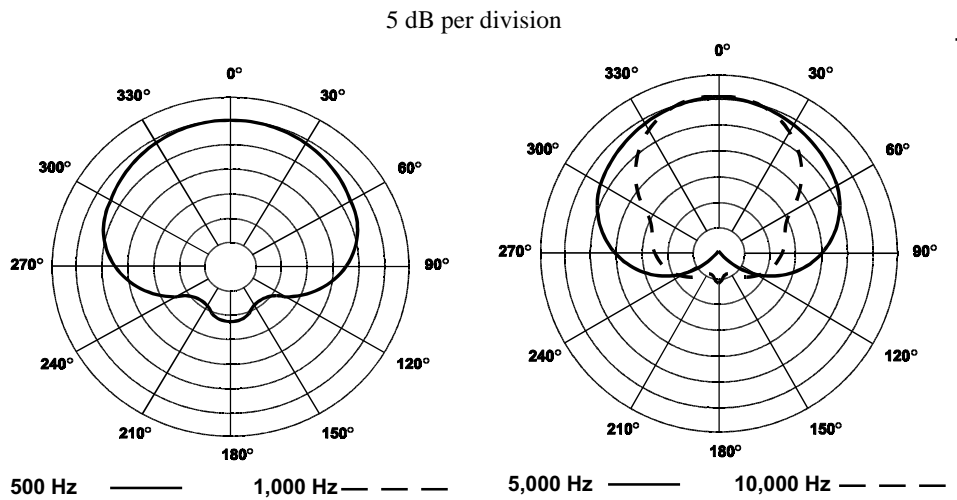

**Figure 3—Dimensions**

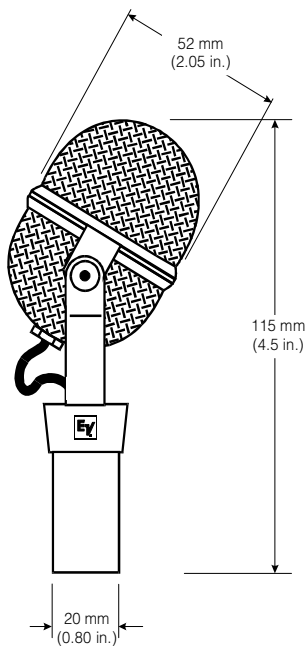

# N/D468 Supercardioid Instrument Microphone

## Specifications

### Frequency Response,

#### Close Response:

30-22,000 Hz

#### Far Response:

60-22,000 Hz

### Polar Pattern:

Supercardioid

### Sensitivity,

#### Open Circuit Voltage @ 1 kHz:

3.1 mV/pascal

### Power level @ 1 kHz:

-51 dB

(0 dB = 1mW/pascal)

### Dynamic Range:

144 dB

### Equivalent Output Noise:

14 dB A weighted

(0 dB = 0.00002 pascal)

### Polarity:

Positive pressure on diaphragm causes

positive voltage on pin 2 ref. pin 3

### Impedance:

150 ohms balanced (low-Z)

### Materials,

#### Grill Screen:

Memraflex™

#### Finish:

Nonreflecting black

### Accessories Included:

311 stand clamp

Soft zippered "gig" bag

### Dimensions,

#### Length:

115 mm (4.5 in.)

#### Diameter:

52 mm (2.05 in.)

#### Shank:

20 mm (0.80 in.)

### Net Weight:

190 g (6.7 oz)

### Shipping Weight:

453 g (16 oz)

MADE IN USA

# Electro-Voice®

600 Cecil Street, Buchanan, MI 49107

616/695-6831, 616/695-1304 Fax

©EVI Audio 1998 • Litho in U.S.A.

MICROPHONES—N/DYM®

Part Number 534570-9805