

SHOWN WITHOUT GRILLE

## MTH-4.5/64B Manifold Technology® Midbass/Mid-Frequency/ High-Frequency Sound Reinforcement System

- Sonically improved lower midrange
- 60° x 40° constant-directivity pattern
- Larger MT rectangular enclosure
- High acoustic output, low distortion
- Manifold Technology® enables smaller and lighter loudspeaker arrays
- MT systems with different coverage patterns and output capabilities may be mixed and matched
- Unique rigging scheme for flexible array design and quick assembly
- Available without rigging hardware
- Available carpeted or painted

### SPECIFICATIONS

**Frequency Response** (measured in farfield, calculated to one meter on axis, swept sine wave, one watt into midbass section, anechoic environment; see Figure 1):

150-20,000 Hz

**Recommended Crossover Frequencies:**

160 Hz, 1,600 Hz, 8,000 Hz

**Efficiency, MB/MF/HF:**

14/25/25%

**Long-Term Average Power-Handling Capacity** (per EIA RS-426-A 1980; see Power Handling Section),

MB/MF/HF: 1,200/240/120

**Maximum Long-Term Average Midband Acoustic Output:**

230 watts

**Sensitivity (SPL at one meter, indicated input power, anechoic environment, band-limited pink-noise signal), MB/MF/HF,**

1/1/1 Watt: 109/113.5/108 dB

1,200/240/120 Watts: 140/137.5/129 dB

**Beamwidth** (angle included by 6-dB-down points on polar responses, indicated one-third-octave bands of pink noise; see Figures 3 and 4),

500-16,000 Hz, Horizontal:  
60° (+30°, -12°)

500-16,000 Hz, Vertical:  
40° (+20°, -12°)

**Directivity Factor  $R_s$  (Q), 500- to 16,000-Hz Median** (see Figure 5):

24.8 (+15.1, -12.8)

**Directivity Index  $D_s$ , 500- to 16,000-Hz Median** (see Figure 5):

14.0 dB (+2.1 dB, -3.1 dB)

**Distortion, 120 dB SPL at 1 Meter, Shaped Spectrum** (see Figure 6),

Second Harmonic,  
200 Hz: 0.9%

1,000 Hz: 0.6%

3,000 Hz: 2.2%

10,000 Hz: 1.8%

**Third Harmonic,**

200 Hz: 0.3%

1,000 Hz: 0.6%

3,000 Hz: 0.3%

10,000 Hz: 0.7%

**Transducer Complement,**

**MB:** Four DL10X 10-inch drivers, integrated 60° x 40° horn

**MF:** Four DH2Amt compression drivers HP64, 60° x 40° horn

**HF:** Two DH2As1-16 compression drivers HP64, 60° x 40° horn

**Impedance (MB1 and MB2 paralleled; see Figures 2 and 7),**

**Nominal, MB/MF/HF:**

4/8/8 ohms

**Minimum, MB/MF/HF:**

2.6/6.8/7.5 ohms

**Input Connections:**

Neutrik Speakon® NL8MPR

**Enclosure Materials, Structural, All Versions:**

14-ply birch plywood

**Finish,**

MTH-4.5/64BC, MTH-4.5/64BCF:

Black carpet

MTH-4.5/64BP, MTH-4.5/64BF:

Black textured paint

**Hanging (MTH-4.5/64BCF and MTH-4.5/64BPF only):**

Two-point flying system (tracks accept New Haven NH32102-1 fittings)

**Dimensions,**

Height: 91.4 cm (36.00 in.)

Width: 91.4 cm (36.00 in.)

Depth: 75.9 cm (29.88 in.)

**Net Weight:**

171 kg (377 lb)

**Shipping Weight:**

193 kg (425 lb)

### DESCRIPTION

The Electro-Voice MTH-4.5/64B midbass/mid-frequency/high-frequency loudspeaker system

is a member of the family of Manifold Technology® MT loudspeaker systems designed for high-level sound reinforcement in concert-sound touring and permanent-installation applications. The MTH-4.5/64B is an active, three-way, horn-loaded, 60° x 40° constant-directivity system with a rectangular enclosure, utilizing four high-power midbass drivers in the midbass-frequency band, four high-power compression drivers in the mid-frequency band and two high-power compression drivers in the high-frequency band. This configuration results in exceptionally high acoustic output from a small enclosure. The MTH-4.5/64B may be combined with other members of the MT-4 and MT-2 loudspeaker family. The combination of the MTH-4.5/64B loudspeaker system and the MTL-4B low-frequency loudspeaker system form the MT-4/64B full-range system. There are four models in the MTH-4.5/64B series: the MTH-4.5/64BCF (carpeted finish with flying hardware), the MTH-4.5/64BC (carpeted finish without flying hardware), the MTH-4.5/64BPF (painted finish with flying hardware) and the MTH-4.5/64BP (painted finish without flying hardware).

The MTH-4.5/64B midbass section utilizes four high-efficiency, low-distortion DL10X 10-inch midbass drivers coupled to a unique phase plug (U.S. Patent No. 4,718,517). An Aperiodic Enhancer™, this phase plug extends the upper-end response by making use of the fact that only the apex area of the cone near the voice coil is in motion at the higher frequencies, and automatically adjusts the acoustic loading to maximize acoustic output. The output of the four drivers is summed through a midbass manifold (U.S. Patent No. 4,923,021) and coupled to a 60° x 40° constant-directivity horn.

The MTH-4.5/64B mid-frequency section contains four DH2Amt compression drivers manifolded onto a 60° x 40° constant-directivity horn. The DH2Amt (8-ohm, 1.0-inch screw-on version of the DH2A) features a powerful motor

**MTH-4.5/64B SPECIFICATION GRAPHICS**

**FIGURE 1 — MTH-4.5/64B Axial Frequency Response**

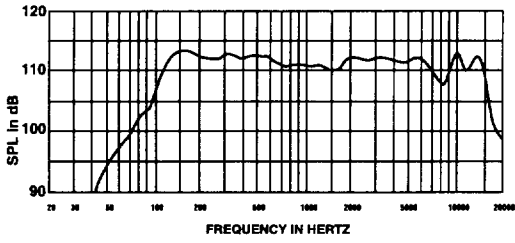

**FIGURE 2 — MTH-4.5/64B Impedance vs. Frequency**

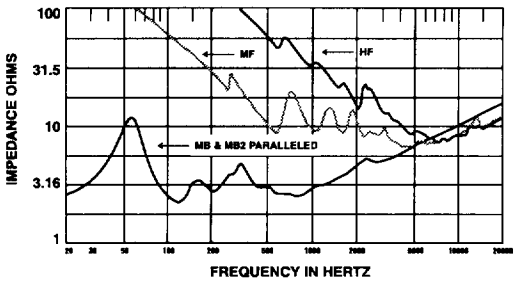

**FIGURE 3 — MTH-4.5/64B Polar Response**

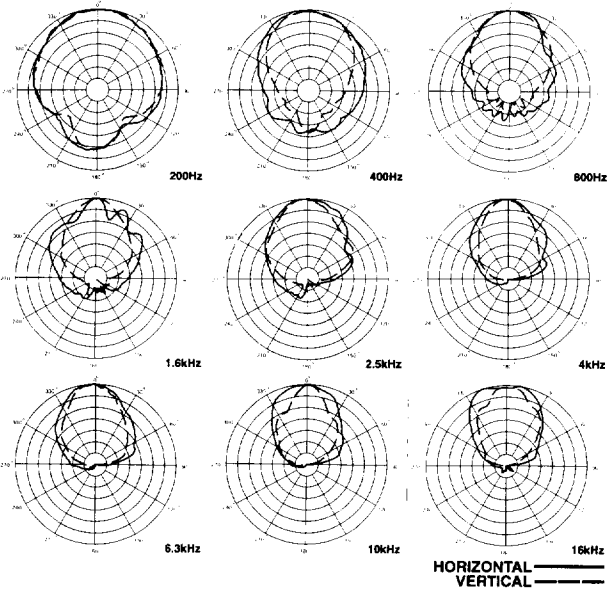

**FIGURE 4 — Beamwidth vs. Frequency**

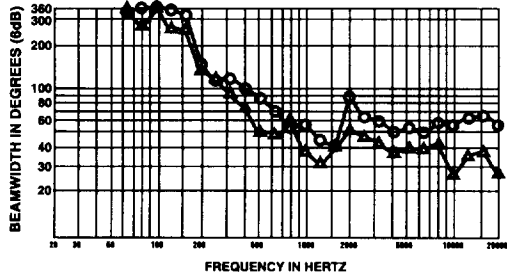

**FIGURE 5 — MTH-4.5/64B Directivity vs. Frequency**

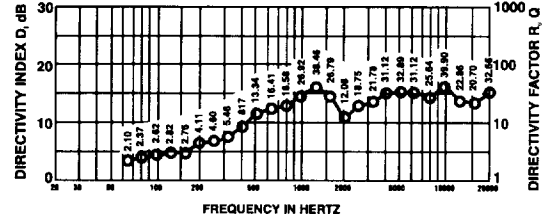

**FIGURE 6 — MTH-4.5/64B Harmonic Distortion**

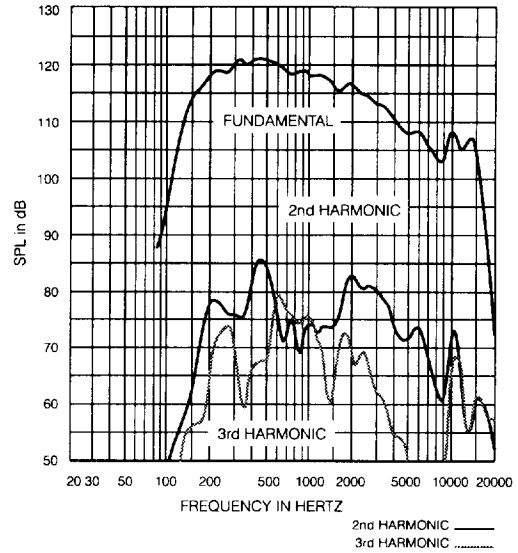

**FIGURE 7 — MTH-4.5/64B Wiring Diagram**

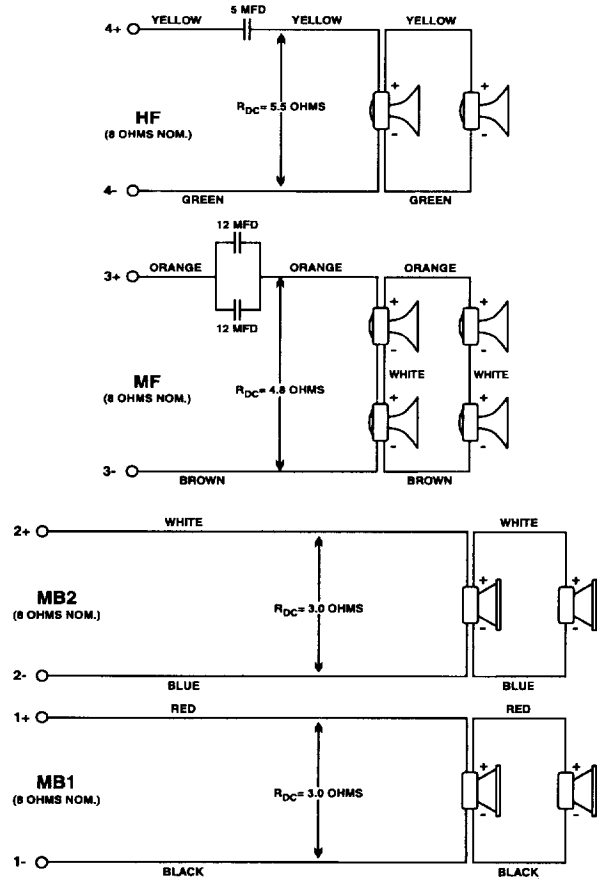

structure and titanium diaphragm for maximum linear acoustic output, extended high-frequency response and accurate transient response. The outputs of the four drivers are summed through the MTA-42 high-frequency manifold (U.S. Patent No. 4,629,029) and coupled to an HP64 horn. The HP64 is a member of the HP TransPlanar™ horn series (U.S. Patent No. 4,685,532) that features beamwidth-control vanes as part of the waveguide to correct the very-high-frequency beamwidth anomalies that typically plague 2.0-inch-throat horns.

The MTH-4.5/64B high-frequency section contains two DH2AS1-16 compression drivers manifolded onto a 60° x 40° constant-directivity horn. The DH2AS1-16 (16-ohm, 1.375-inch bolt-on version of the DH2A) also features a powerful motor structure and titanium diaphragm for maximum linear acoustic output, extended high-frequency response and accurate transient response. The outputs of the two drivers are summed through the MTA-22 high-frequency manifold (U.S. Patent No. 4,629,029) and coupled to an HP64 constant-directivity horn; identical to the horn used in the mid-frequency section. The use of the same horn in the mid- and high-frequency sections ensures identical coverage patterns and minimizes path-length differences between the two frequency bands.

All versions of the MTH-4.5/64B are constructed of 0.75-inch-thick, 14-ply birch plywood and extremely well braced to survive the rigors of the road. The MTH-4.5/64BCF (flying) and MTH-4.5/64BC (non-flying) systems are covered with black Ozite Super TNT carpeting, the most rugged in the industry. For permanent installation applications, the MTH-4.5/64BPF (flying) and MTH-4.5/64BP (non-flying) systems are available with a black textured paint finish. The MTH-4.5/64BCF (carpeted) and MTH-4.5/64BPF (painted) systems incorporate a two-point flying system. All models feature a black nylon cloth grille. The RD-1 removable dolly is available for use with the carpeted MTH-4.5/64BCF and MTH-4.5/64BC versions for portable applications.

#### APPLICATIONS

The MTH-4.5/64B is ideal for any professional concert-sound touring or permanent-installation application requiring high sound pressure levels with low distortion from a compact enclosure. The Manifold Technology® design maximizes the acoustic output per enclosure frontal area, acoustic output per enclosure bulk volume, and acoustic output per enclosure weight of the loudspeaker system. This enables loudspeaker arrays to be constructed that are significantly smaller and lighter than would be obtainable with conventional loudspeaker-system designs. The MTH-4.5/64B may be combined with other members of the MT-4 and MT-2 loudspeaker family, providing the array designer a variety of coverage angles, acoustic output and enclosure sizes from which to choose. For full-range applications, the MTH-4.5/64B may be combined with the MTL-4 or MTL-2 low-frequency sound-reinforcement systems. (The MTL-4B is a low-frequency system with a rectangular enclosure that is dimensionally identical to the MTH-4.5/64B.) For optimal acoustic performance of the MT loudspeaker systems, the Electro-Voice Dx34 digital electronic crossover/equalization/time-delay/limiter unit is recommended.

Careful attention was paid to details to provide both the touring company and sound contractor a convenient and timesaving sound reinforcement package. The MTH-4.5/64B dimensions were chosen for efficient truck pack and high-density array design. The systems may be stacked three high and three wide in a standard truck box, enabling 14,000 watts of sound system to be accommodated in only three feet of truck-floor length. The two-point rigging system offers flexible array design and efficient assembly. To facilitate service, a variety of screws, washers and hex key wrenches are provided with each loudspeaker system. In addition, there are wiring diagram labels in convenient locations inside the enclosure.

#### FREQUENCY RESPONSE

The MTH-4.5/64B frequency response (shown in Figure 1) was measured on axis in the farfield in an anechoic environment using a swept sine wave signal. The Dx34 digital electronic unit was used to provide the necessary crossover filters, equalization and time delay. No high-pass crossover filters were applied to the low end of the midbass section. One watt of power (2.00 volts rms at 500 Hz) was applied to the midband of the midbass section. The sound pressure level was normalized for an equivalent one-meter distance.

#### DIRECTIVITY

The directional response of the MTH-4.5/64B was measured in an anechoic environment at a distance of 6.1 meters (20 feet) using 1/3-octave-filtered pink noise. A full spherical measurement system was used. The Dx34 digital electronic unit was used to provide the necessary crossover filters, equalization and time delay. The polar response of the loudspeaker system at selected 1/3-octave frequencies is shown in Figure 3. The frequencies selected are fully representative of the polar response of the system. The beamwidth of the system utilizing the complete 1/3-octave polar data is shown in Figure 4. The Directivity Factor  $R_0(Q)$ , and Directivity Index,  $D_0$ , are shown in Figure 5. Complete AcoustaCADD™ data is available for the MTH-4.5/64B loudspeaker system.

#### DISTORTION

Distortion for the MTH-4.5/64B (shown in Figure 6) was measured on axis in the farfield in an anechoic environment with an input signal that would result in a sound pressure level of 120 dB at one meter. The Dx34 digital electronic unit was used to provide the necessary crossover filters, equalization and time delay. A 24-dB-per-octave, high-pass crossover filter at 160 Hz was applied to the low end of the midbass section. A frequency spectrum typical of close-miked rock music was employed. The sound pressure level was normalized for an equivalent one-meter distance. Plots of second- and third-harmonic distortion are shown referenced to the fundamental.

#### POWER-HANDLING CAPACITY

Electro-Voice components and systems are manufactured to exacting standards to ensure reliability in continuous use in arduous real-life conditions. Besides utilizing industry-standard power tests, extreme in-house power tests which push the performance boundaries of the loudspeakers are also performed for an extra measure of reliability. The MT systems are rated as per the EIA RS-426-A 1980 Loudspeaker Power Rating, Full Range Test, which uses a shaped-random-noise signal to simu-

late typical music to test the mechanical and thermal capabilities of the loudspeakers. The Dx34 digital electronic unit was used to provide the necessary crossover filters and equalization during power testing. Specifically, the MTH-4.5/64B passes the EIA RS-426-A 1980 power test with the following test parameters:

#### Midbass Section (MB1 & MB2 paralleled):

$P_{E(MAX)}$ :	1,200 watts
Test Voltages:	45.5 volts rms 91.0 volts peak
$R_{SR} (1.15 \times R_E)$ :	1.73 ohms

#### Mid-Frequency Section:

$P_{E(MAX)}$ :	240 watts
Test Voltages:	36.4 volts rms 72.8 volts peak
$R_{SR} (1.15 \times R_E)$ :	5.52 ohms

#### High-Frequency Section:

$P_{E(MAX)}$ :	120 watts
Test Voltages:	27.6 volts rms 55.2 volts peak
$R_{SR} (1.15 \times R_E)$ :	6.33 ohms

#### CROSSOVER, EQ AND TIME DELAY

The usable frequency ranges of the individual MTH-4.5/64B sections are 150-2,000 Hz for the midbass section, 1,200-20,000 Hz for the mid-frequency section and 6,000-20,000 for the high-frequency section. Crossover frequencies of 160, 1,600 and 8,000 Hz with 24-dB-per-octave slopes are recommended. For full-range applications, the MTL-4B low-frequency loudspeaker system is recommended for use with the MTH-4.5/64B. For optimal acoustic performance, the Electro-Voice Dx34 digital electronic crossover/equalization/time-delay unit is recommended.

The Dx34 is a programmable, two-in/four-out, digital electronic unit which may be configured for stereo two-way, mono three-way plus sub-woofer, or mono four-way operation. Each output section includes crossover filters, equalization, limiting, time delay, polarity and gain adjustment; the parameters of which all may be programmed and stored by the user. In the mono, four-way configuration, the Dx34 includes a factory preset for optimal performance of the MT-4/64B loudspeaker system (the MTH-4.5/64B and MTL-4B systems combined) that utilizes Linkwitz-Riley 24-dB-per-octave crossover filters at 160, 1,600 and 8,000 Hz. Each output section has equalization specifically matched to the loudspeaker system, and time delay set to achieve zero lobing error and time alignment between frequency bands. In addition, the output levels of each frequency band are set so that, with the output level controls set in the zero-dB position, the loudspeaker system will have a flat frequency response in an anechoic environment when used with amplifiers having identical gain.

#### ELECTRICAL CONNECTION AND SYSTEM WIRING

Electrical connections to the MTH-4.5/64B are made on the back of the enclosure via an 8-pin connector. There are two connectors on the input panel to allow paralleling of other MTH-4.5/64B systems. The Neutrik Speakon® NL8MPPR is used for both connections. One mating Neutrik Speakon® NL8FC cable-end connector is supplied with each loudspeaker system. The pin assignments are as follows:

Pin 1+:	MB1 (+)	Pin 1-:	MB1 (-)
Pin 2+:	MB2 (+)	Pin 2-:	MB2 (-)
Pin 3+:	MF (+)	Pin 3-:	MF (-)
Pin 4+:	HF (+)	Pin 4-:	HF (-)

The midbass section has four 8-ohm drivers; however, the acoustic loading of the phase plugs and horn increases their electrical impedance to a nominal 16 ohms each. These four drivers are wired in paralleled pairs, resulting in two nominal 8-ohm loads, with one pair connected to Pins 1+/- and the other pair to Pins 2+/- . The mid-frequency section has four 8-ohm drivers wired in a parallel-series arrangement, resulting in a single 8-ohm nominal load connected to Pins 3+/- . The high-frequency section has two 16-ohm drivers wired in parallel, resulting in a single 8-ohm nominal load connected to Pins 4+/- . A wiring diagram of the loudspeaker system is shown in Figure 7. The electrical impedance versus frequency is shown in Figure 2.

#### FLYING THE MT SYSTEMS

A manual entitled the *MT Flying Manual* is available from Electro-Voice, and is included with each flying MT loudspeaker system. A brief introductory overview is included here. The *MT Flying Manual* should be consulted for complete structural specifications and detailed information on safely suspending and using the MT systems.

The MTH-4.5/64BCF (carpeted) and MTH-4.5/64BPF (painted) are versions of the MTH-4.5/64B loudspeaker system that include flying hardware. The MT systems incorporate a unique two-point flying system that permits a wide range of vertical angle adjustment, and offers maximum flexibility in array design and implementation for both touring sound and permanent installations. The quick-release, aircraft L-track-type, hardware design allows arrays of loudspeakers to be assembled (and disassembled) very-quickly, and offers such flexibility in the vertical angling of cabinets that pull-up points are usually unnecessary. Furthermore, all of the flying MT-4B and MT-2B loudspeaker models include the same rigging hardware, allowing the different models to be mixed as necessary throughout an array.

The rigging track accepts New Haven NH32102-1 double-stud ring fittings. Individual rigging points have typical break-strength ratings of 3,750-4,000 pounds; which translates to working-load ratings of 750-800 pounds for a 5:1 safety factor. (Consult the *MT Flying Manual* for specific structural strength ratings and limitations.) The enclosures may be oriented with the rigging track on the sides of the enclosure, or on the top and bottom, and may be daisy chained together as long as the safety factor is 5:1 or greater, and local regulations are met. Electro-Voice offers a line of flying-hardware accessories for use with the MT loudspeaker systems.

**CAUTION: the MT loudspeaker systems should be suspended overhead only in accordance with the procedures and limitations specified in the *MT Flying Manual* and manual update notices.**

#### FIELD SERVICE

In the unlikely event that the MTH-4.5/64B should require service, the midbass drivers can be accessed by removing the back of the enclosure using a #2 Phillips screwdriver. The midbass drivers can be unbolted using a 5/32-inch hex-key wrench, and can be lifted away from the baffle board and slid out around the

phase plugs. There is a wiring diagram label for the midbass section located on the back of the enclosure near the drivers. The mid- and/or high-frequency drivers can be accessed by removing the grille using a #2 Phillips screwdriver, and removing the MF/HF horn baffle using a 5/32-inch hex-key wrench. The mid-frequency drivers can be unscrewed from the four-driver manifold, while the high-frequency drivers can be unbolted from the two-driver manifold using a 5/32-inch hex-key wrench. There is a wiring diagram label for the mid- and high-frequency section located on the horn-baffle assembly near the drivers. As a further service convenience, a hardware kit that includes a 5/32-inch hex key and an assortment of spare screws and washers is included with every MTH-4.5/64B loudspeaker system.

A 10-inch-midbass-driver failure will require the entire driver to be returned to an authorized Electro-Voice service center for repair. A mid- or high-frequency-driver failure can be repaired in the field by replacing the diaphragm assembly; or, if desired, the entire driver can be returned to an authorized service center for repair. The following service parts are available from the Service Department in Buchanan, Michigan:

MTH-4.5/64B Service Data Sheet: #533171  
 HF: #82816-XX 16-ohm DH2A Diaphragm Kit  
 #832-2349 DH2AS1-16 Driver  
 MF: #81161-XX, 8-ohm DH2A Diaphragm Kit  
 #832-1721 DH2Amt Driver  
 MB: #810-1491 DL10X Driver

#### ARCHITECTS' AND ENGINEERS' SPECIFICATIONS

The loudspeaker system shall be a three-way active midbass/mid-frequency/high-frequency system. The midbass section shall operate from 150-2,000 Hz with a sensitivity of 109 dB for one watt at one meter, and consist of four 10-inch cone drivers, each individually coupled to a midbass phase plug, then collectively manifolded and coupled to a 60° x 40° constant-directivity horn, have a total input impedance of 4 ohms, and have a power rating of 1,200 watts as per EIA RS-426-A 1980. The mid-frequency section shall operate from 1,200-20,000 Hz with a sensitivity of 113.5 dB for one watt at one meter, and consist of four compression drivers collectively manifolded and coupled to a 60° x 40° constant-directivity horn, have a total input impedance of 8 ohms, and have a power rating of 240 watts as per EIA RS-426-A 1980. The high-frequency section shall operate from 6,000-20,000 Hz with a sensitivity of 108 dB for one watt at one meter, and consist of two compression drivers collectively manifolded and coupled to a 60° x 40° constant-directivity horn, have a total input impedance of 8 ohms, and have a power rating of 120 watts as per EIA RS-426-A 1980. The total system shall have a uniform on-axis frequency response from 150-20,000 Hz, and shall have a nominal horizontal beamwidth of 60° and a nominal vertical beamwidth of 40°. The loudspeaker system shall have an enclosure constructed from 0.75-inch thick, 14-ply birch plywood, be finished with a black carpet (or a black textured paint), have a black nylon grille, and have a two-point rigging system that will accept New Haven NH32102-1 type double-stud ring fittings (if applicable). The loudspeaker

enclosure shall be 91.4 cm (36.00 in.) high, 91.4 cm (36.00 in.) wide and 75.9 cm (29.88 in.) deep, and weigh 177 kg (377 lb). The loudspeaker system shall be the Electro-Voice MTH-4.5/64B (MTH-4.5/64BCF, MTH-4.5/64BC, MTH-4.5/64BPF or MTH-4.5/64BP).

#### UNIFORM LIMITED WARRANTY

Electro-Voice products are guaranteed against malfunction due to defects in materials or workmanship for a specified period, as noted in the individual product-line statement(s) below, or in the individual product data sheet or owner's manual, beginning with the date of original purchase. If such malfunction occurs during the specified period, the product will be repaired or replaced (at our option) without charge. The product will be returned to the customer prepaid. **Exclusions and Limitations:** The Limited Warranty does not apply to: (a) exterior finish or appearance; (b) certain specific items described in the individual product-line statement(s) below, or in the individual product data sheet or owner's manual; (c) malfunction resulting from use or operation of the product other than as specified in the product data sheet or owner's manual; (d) malfunction resulting from misuse or abuse of the product; or (e) malfunction occurring at any time after repairs have been made to the product by anyone other than Electro-Voice or any of its authorized service representatives. **Obtaining Warranty Service:** To obtain warranty service, a customer must deliver the product, prepaid, to Electro-Voice or any of its authorized service representatives together with proof of purchase of the product in the form of a bill of sale or receipted invoice. A list of authorized service representatives is available from Electro-Voice at 600 Cecil Street, Buchanan, MI 49107 (616/695-6831 or 800/234-6831). **Incidental and Consequential Damages Excluded:** Product repair or replacement and return to the customer are the only remedies provided to the customer. Electro-Voice shall not be liable for any incidental or consequential damages including, without limitation, injury to persons or property or loss of use. Some states do not allow the exclusion or limitation of incidental or consequential damages so the above limitation or exclusion may not apply to you. **Other Rights:** This warranty gives you specific legal rights, and you may also have other rights which vary from state to state.

**Electro-Voice Speakers and Speaker Systems** are guaranteed against malfunction due to defects in materials or workmanship for a period of five (5) years from the date of original purchase. The Limited Warranty does not apply to burned voice coils or malfunctions such as cone and/or coil damage resulting from improperly designed enclosures. Electro-Voice active electronics associated with the speaker systems are guaranteed for three (3) years from the date of original purchase. Additional details are included in the Uniform Limited Warranty statement.

**Electro-Voice Flying Hardware** (including enclosure-mounted hardware and rigging accessories) is guaranteed against malfunction due to defects in materials or workmanship for a period of one (1) year from the date of original purchase. Additional details are included in the Uniform Limited Warranty statement.

**Electro-Voice Accessories** are guaranteed against malfunction due to defects in materials or workmanship for a period of one (1) year from the date of original purchase. Additional details are included in the Uniform Limited Warranty statement.

Service and repair address for this product: Electro-Voice, Inc., 600 Cecil Street, Buchanan, Michigan 49107 (616/695-6831 or 800/234-6831).

Specifications subject to change without notice.



**ELECTRO-VOICE** a MARK IV company **600 Cecil Street, Buchanan, Michigan 49107**

MANUFACTURING PLANTS AT ■ BUCHANAN, MI ■ NEWPORT, TN ■ SEVIERVILLE, TN ■ OKLAHOMA CITY, OK ■ GANANOQUE, ONT.  
 © Electro-Voice, Inc. 1996 ■ Litho in U.S.A. Part Number 533169 — 9607