

ALTEC
LANSING®

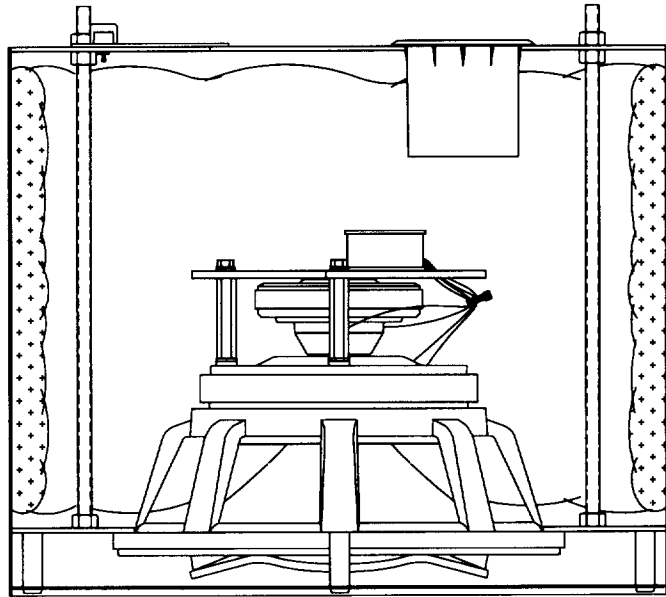

EP925-8B EP925-32T EP925-60T EP925-100T

Duplex® Ceiling Loudspeaker Systems

- Ease of installation
- Architecturally pleasing
- High SPL (97 dB, 1 watt at 1 meter)
- Multiple transformer options
- System ships complete from factory
- 925-8B component in a 17¾-inch diameter enclosure

Description

The Altec Lansing EP925-8B series Duplex® loudspeaker systems are complete two-way ceiling loudspeaker packages. The package consists of a rear enclosure, grille, and the 925-8B two-way 12-in. Duplex® loudspeaker which features a rectangular-coverage 90° x 90° horn driven by a 1-in. compression driver coaxially mounted to a 12-in. low-frequency cone driver with a high-temperature voice-coil assembly. The system is offered in either a nontransformer, 32-watt, 60-watt or 100-watt line-matching transformer package. Each system utilizes a dual-section cross-over network with a self-resetting protection circuit for the compression driver.

The EP925-32T utilizes a transformer that offers a selection of 4, 8, 16 and 32 watts delivered to the loudspeaker system using either 70-V or 100-V lines.

The EP925-60T utilizes a transformer that offers a selection of 7.5, 15, 30 and 60 watts delivered to the loudspeaker system using either 25-V, 70-V or 100-V lines.

The EP925-100T utilizes a transformer that offers a selection of 50, 70, 100, 140 and 200 watts delivered to the loudspeaker system using either 70-V or 100-V lines.

The rear enclosure provides an optimum internal volume, ensuring extended low-frequency performance. It is constructed from rugged heavy-gauge, cold-rolled steel, finished with a black-wrinkle epoxy powder coat. In addition, the interior is lined with a polyester batting blanket to ensure optimum acoustic performance. Three hanging points are provided through the rear cover each consisting of a ¾-in. length of 3/8-16 threaded rod or "all-thread" (see Mounting the System in a Ceiling). For the EP925-8B nontransformer version, the rear cover provides access to a dual terminal block for direct connection to the speaker. For the EP925-32T, EP925-60T and EP925-100T transformer models, the rear cover provides access to both a dual terminal block for direct connection to the speaker and an 8-pin terminal block that allows direct connection to each of the transformer taps.

The attached grille is constructed from 16 gauge perforated cold-rolled steel, finished in a semi-gloss black powder-coated enamel. These components have been designed to work together as a complete system in a wide range of different ceiling constructions. They provide wide dispersion, high efficiency, high-maximum output, ease of installation and wide-range reproduction of music or voice.

Mounting the System in a Ceiling

Three hanging points are provided through the rear cover consisting of ¾-in. length of 3/8-16 threaded rod ("all-thread") for use with either the optional EBK-2 kit or by many other obtainable hardware options that can utilize the 3/8-16 male thread.

It is imperative, before beginning the installation, to determine the type of material employed in the ceiling to verify that it can safely accommodate the weight of the system(s).

It is recommended to use all three hanging points with the optional EBK-2 kit, which consists of three 3/8-16 eye-nuts which in turn are screwed securely into each of the "all-thread" protruding through the rear of the enclosure. From these points, the system can be suspended from a girder, beam or appropriate ceiling fixture depending on where the system is being used.

If the speaker system must be mounted inconspicuously, the system can be suspended above a drop ceiling with an existing tile replaced with the optional CG-1, 24-in. x 24-in. white powder-coated perforated grille kit.

EP925 Series Duplex^(S) Ceiling Loudspeaker Systems

EP925 Series Duplex[®] Ceiling Loudspeaker Systems

Selecting a Transformer Tap for Transformer Models

The transformer tap of choice can be obtained by making connection between the ground terminal (#1) and any of the wattage taps indicated on the input label. For the EP925-32T and EP925-100T, either 70-V or 100-V lines can be used. For the EP925-60T, either 25-V, 70-V or 100-V lines can be used - refer to the input panel label to determine the appropriate wattage for the line voltage used.

Architects' and Engineers' Specifications

The loudspeaker systems shall be of the ceiling Duplex[®] type consisting of a rear enclosure, front grille, transformer (for transformer models) and 12-inch Duplex[®]-type loudspeaker. The loudspeaker will feature a single high-frequency compression driver coaxially mounted to a single 305-mm (12-in.) high-power woofer using a 90° x 90° coverage pattern horn. The loudspeaker system shall meet the following criteria: power handling shall be 250 watts of band-limited pink noise with 6-dB crest factor. Frequency response shall be smooth and uniformly usable from 60 Hz to 20 kHz. Pressure sensitivity shall be 97 dB SPL when measured at one meter on axis with one watt of pink noise. The loudspeaker shall weigh 23.8 kg (52.5 lb) (nontransformer).

The Duplex[®] ceiling loudspeaker packages shall be the Altec Lansing models EP925-8B with no transformer, EP925-32T with 32-watt

transformer, EP925-60T with 60-watt transformer and EP925-100T with 100-watt transformer.

Uniform Limited Warranty Statement

Altec Lansing products are guaranteed against malfunction due to defects in materials or workmanship for a specified period, as noted in the individual product-line statement(s) below, or in the individual product data sheet or owner's manual, beginning with the date of original purchase. If such malfunction occurs during the specified period, the product will be repaired or replaced (at our option) without charge. The product will be returned to the customer prepaid.

Exclusions and Limitations: The Limited Warranty does not apply to: (a) exterior finish or appearance; (b) certain specific items described in the individual product-line statement(s) below, or in the individual product data sheet or owner's manual; (c) malfunction resulting from use or operation of the product other than as specified in the product data sheet or owner's manual; (d) malfunction resulting from misuse or abuse of the product; or (e) malfunction occurring at any time after repairs have been made to the product by anyone other than EVI Audio Service or any of its authorized service representatives. **Obtaining Warranty Service:** To obtain warranty service, a customer must deliver the product, prepaid, to EVI Audio Service or any of its authorized service representatives together with proof of purchase of the product in the form of a bill of sale or receipted invoice. A list of autho-

rized service representatives is available from EVI Audio Service at 10500 W. Reno Avenue, Oklahoma, OK 73127 (800/845-8727 or FAX 405/577-3274). **Incidental and Consequential Damages Excluded:** Product repair or replacement and return to the customer are the only remedies provided to the customer. Altec Lansing shall not be liable for any incidental or consequential damages including, without limitation, injury to persons or property or loss of use. Some states do not allow the exclusion or limitation of incidental or consequential damages so the above limitation or exclusion may not apply to you. **Other Rights:** This warranty gives you specific legal rights, and you may also have other rights which vary from state to state.

Altec Lansing Speakers and Speaker Systems are guaranteed against malfunction due to defects in materials or workmanship for a period of five (5) years from the date of original purchase. The Limited Warranty does not apply to burned voice coils or malfunctions such as cone and/or coil damage resulting from improperly designed enclosures. Altec Lansing active electronics associated with the speaker systems are guaranteed for three (3) years from the date of original purchase. Additional details are included in the Uniform Limited Warranty statement.

For technical assistance, contact Technical Support at 800/234-6831 or 616/695-6831, M-F, 8:00 a.m. to 5:00 p.m. Eastern Standard time.

Specifications subject to change without notice.

EP925 Series Duplex^(R) Ceiling Loudspeaker Systems

Figure 1—EP925-8B Frequency Response (on axis, 1 watt/1 meter, anechoic environment)

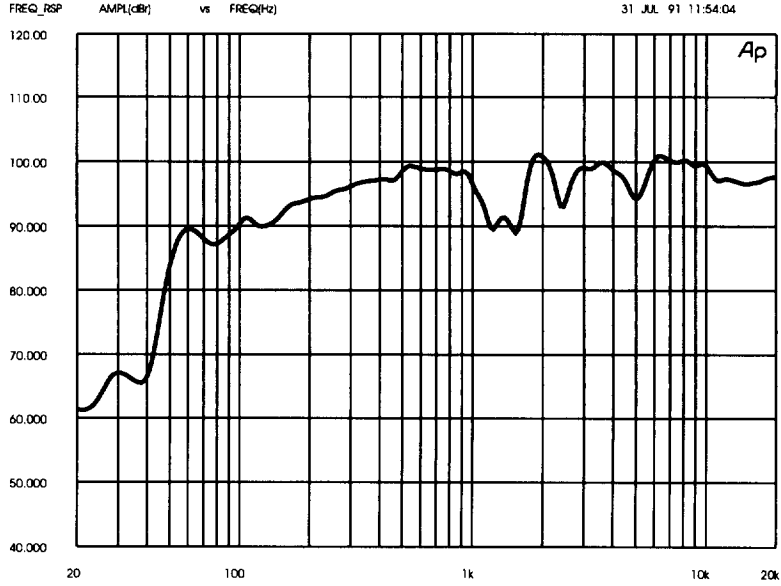
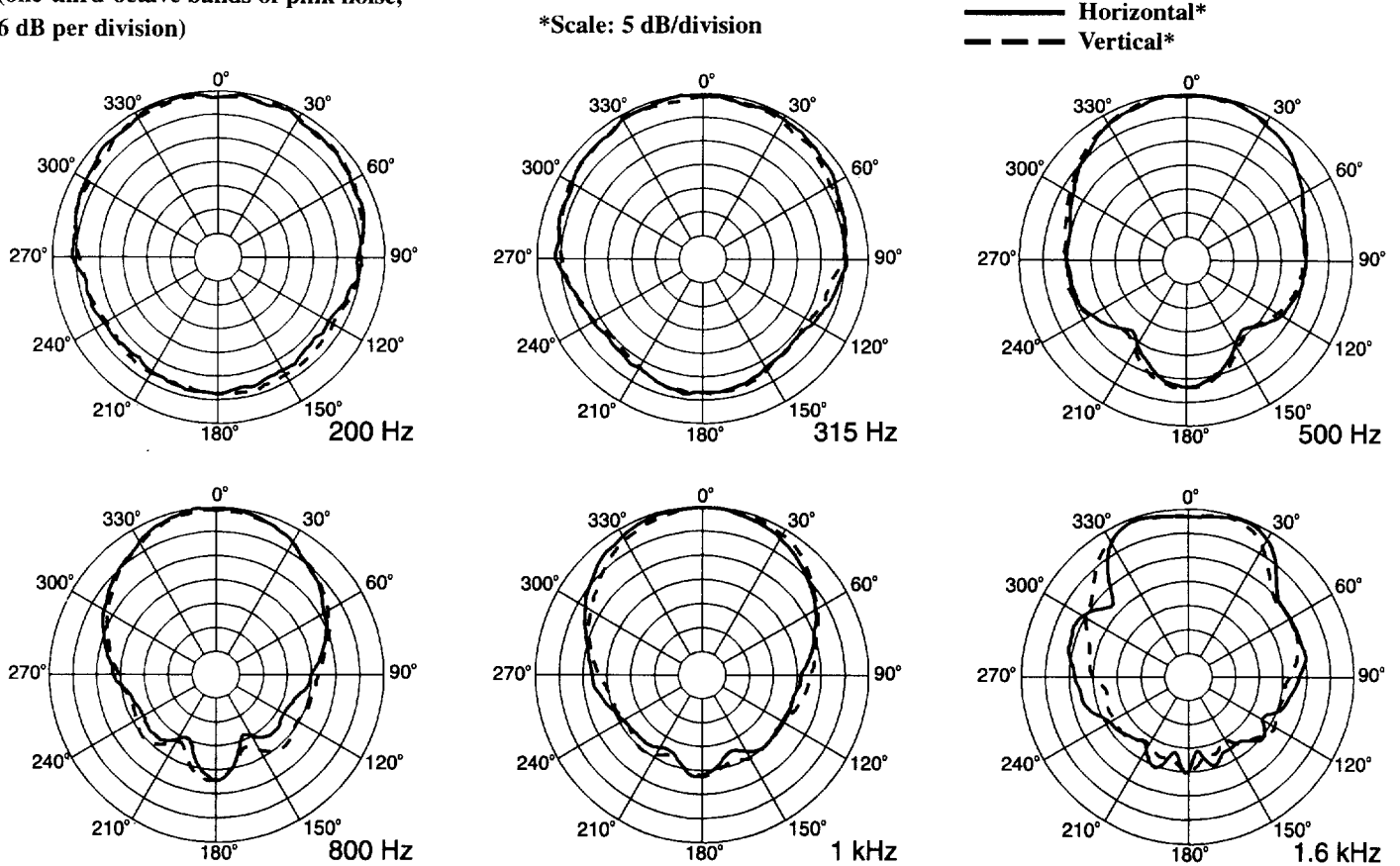

Figure 2—EP925-8B Polar Response (one-third-octave bands of pink noise, 6 dB per division)



EP925 Series Duplex[®] Ceiling Loudspeaker Systems

*Scale: 5 dB/division

— Horizontal*
 - - - Vertical*

EP925 Series Duplex[®] Ceiling Loudspeaker Systems

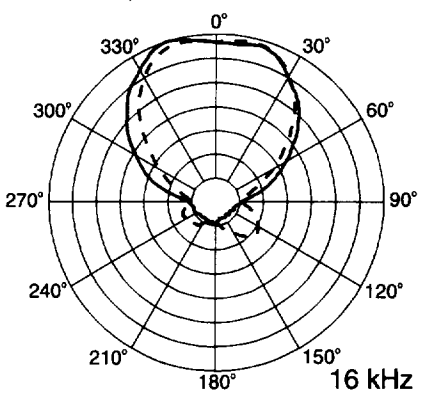
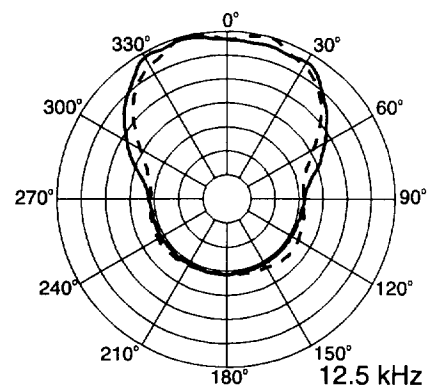
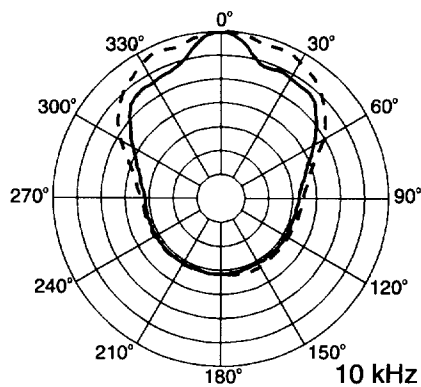
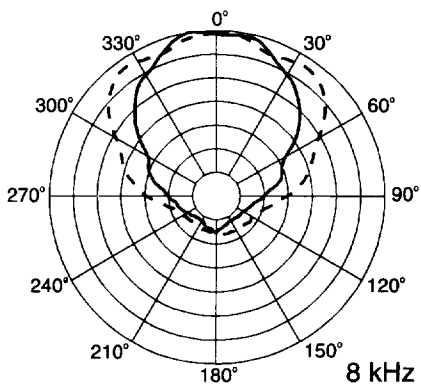
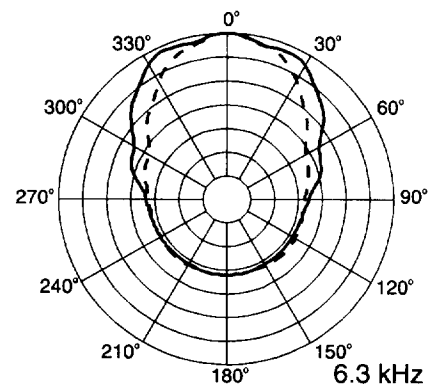
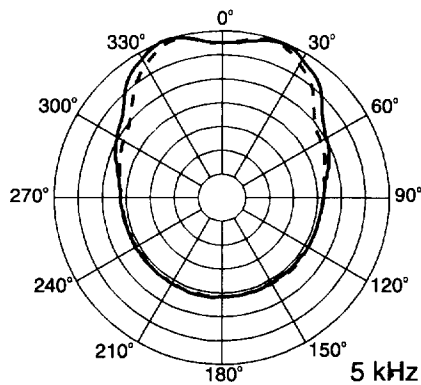
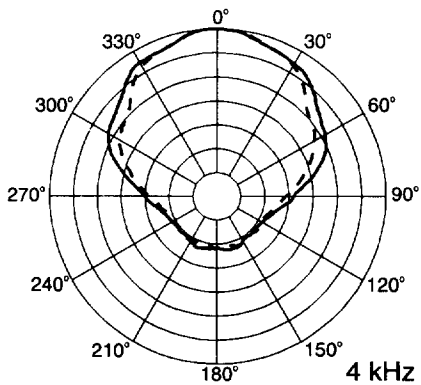
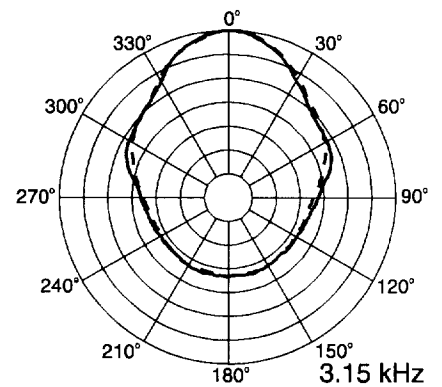
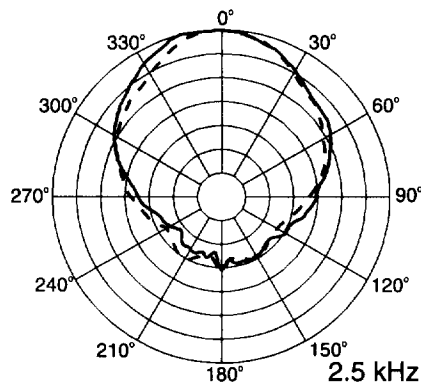
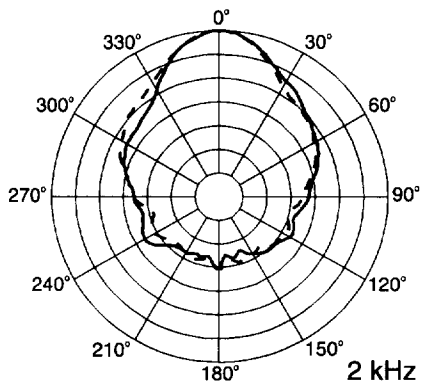

EP925 Series Duplex^(S) Ceiling Loudspeaker Systems

Figure 3—EP925-8B Impedance (Log Scale)

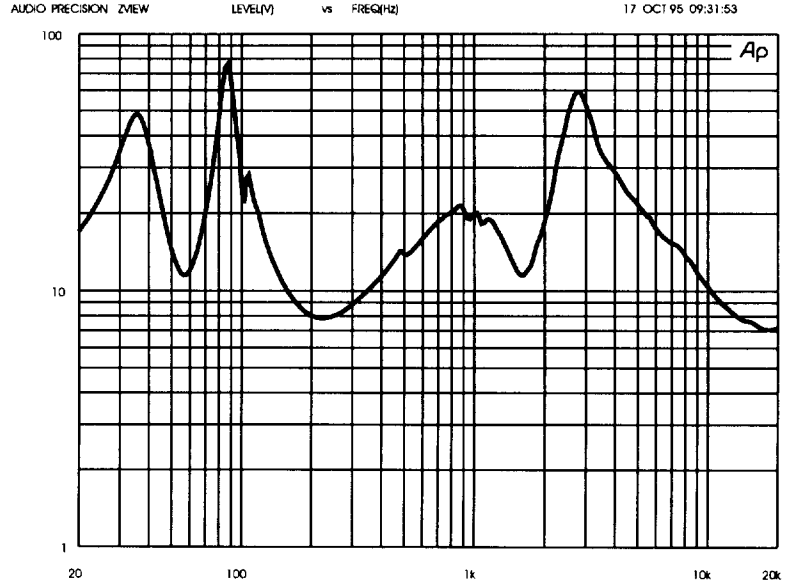

Figure 4—EP925-8B Harmonic Distortion at 0.01 rated power (3.0 W)⁵

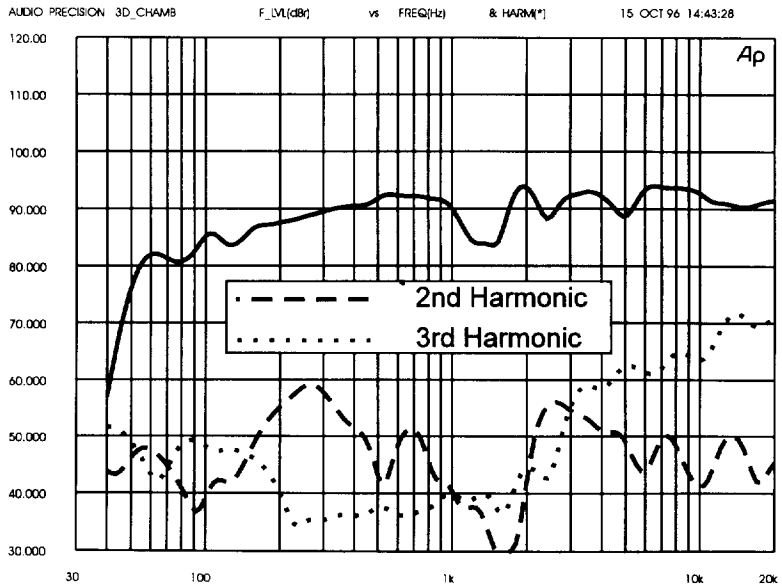
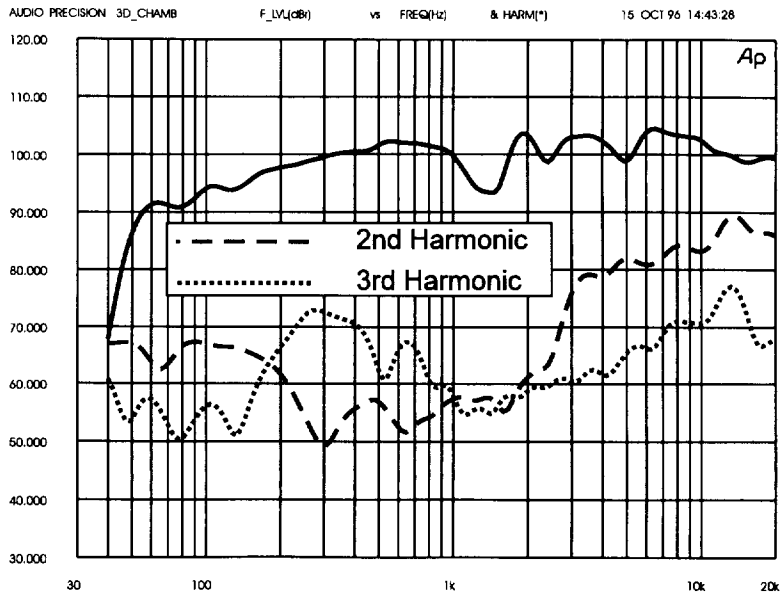

Figure 5—EP925-8B Harmonic Distortion at 0.1 rated power (30 W)⁵



EP925 Series Duplex[®] Ceiling Loudspeaker Systems

Figure 6—EP925-8B Beamwidth

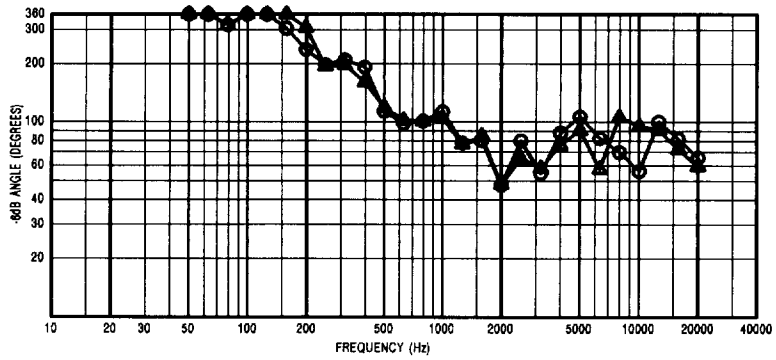

Figure 7—EP925-8B Directivity

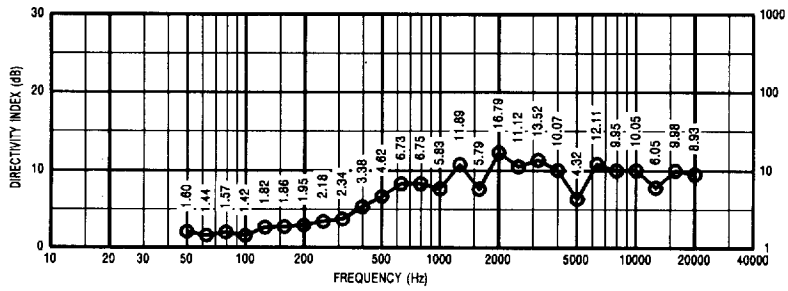
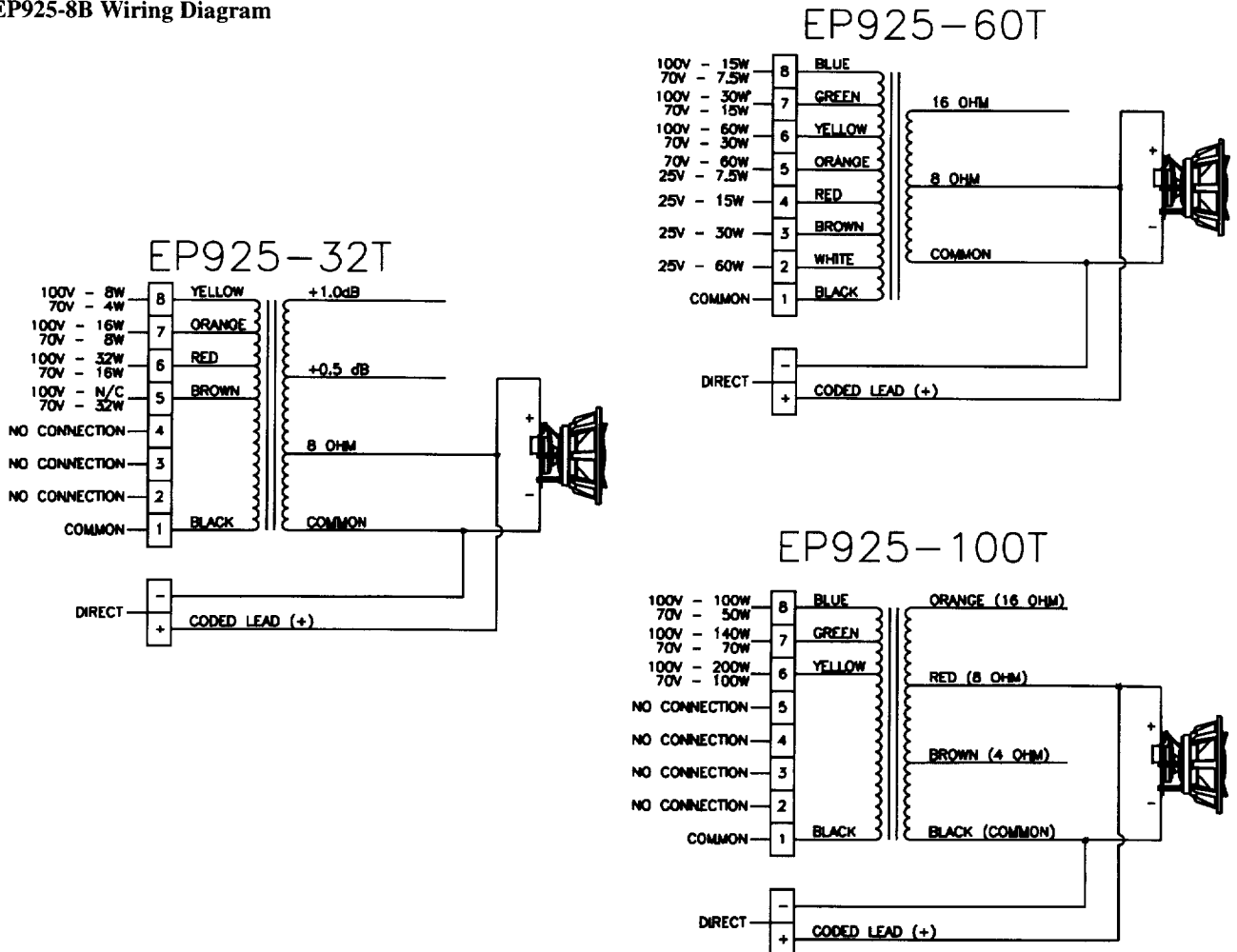
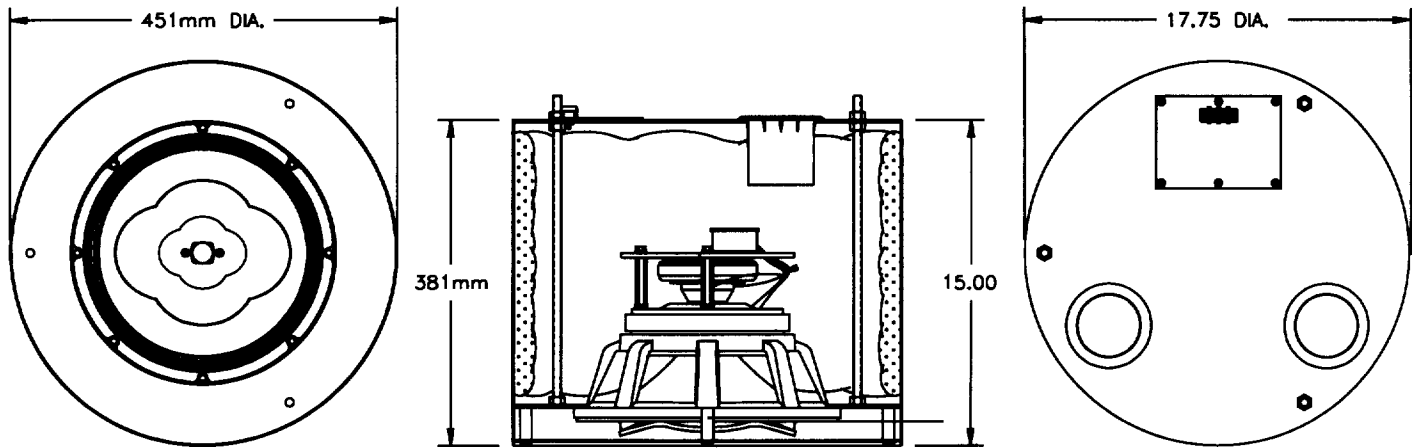

Figure 8—EP925-8B Wiring Diagram



EP925 Series Duplex[®] Ceiling Loudspeaker Systems

Figure 9—EP925-8B Dimensions



EP925 Series Duplex[®] Ceiling Loudspeaker Systems

Specifications

System Type:

Two-way, full-range Duplex[®] loudspeaker systems

Frequency Response (see Figure 1):⁶

60-20,000 Hz²

Pressure Sensitivity,⁶

60-20,000 Hz:
97 dB SPL¹

Beamwidth,

Horizontal, 500-20,000 Hz:

90° (+15°, -40°)

Vertical, 500-20,000 Hz:

90° (+15°, -40°)

Directivity Factor, R_0 (Q), 500-20,000 Hz:

10.4 (+7.7, -4.8)

Directivity Index, D_1 , 500-20,000 Hz:

10.2 dB (+2.7 dB, -3.3 dB)

Power Handling:

250 watts³

Maximum Long-Term Output,

LF (60-20,000 Hz, 250 watts input):
120 dB SPL⁴

Impedance:

7.0 ohms minimum
8.0 ohms nominal

Components,

LF:

305-mm (12-in.), high efficiency
woofer

HF:

25.4-mm (1-in.) exit high-frequency
driver

Replacement LF:

812-2874

Replacement HF:

833-990

Input Terminals:

EP925-8B:

Dual terminal barrier strip with screw
type connector

EP925-32T, -60T and 100T:

Dual terminal barrier strip with screw-
type connector for direct connection
to woofer and an eight-way barrier
strip with screw-type connector for
transformer connections.

Dimensions,

451 mm (17.75 in.) diameter
381 mm (15 in.) depth

Net Weight,

EP925-8B:

23.8 kg (52.5 lb)

EP925-32T:

25.3 kg (55.7 lb)

EP925-60T:

25.2 kg (55.5 lb)

EP925-100T:

27.4 kg (60.5 lb)

Shipping Weight:

EP925-8B:

26.5 kg (58.5 lb)

EP925-32T:

30.0 kg (61.7 lb)

EP925-60T:

27.9 kg (61.5 lb)

EP925-100T:

30.2 kg (66.5 lb)

Finish:

Black-wrinkle powder coat enamel

Accessories:

EBK-2 hardware mounting kit

CG-1 24-in. x 24-in. white grille kit

EP925 Series Duplex^{us} Ceiling Loudspeaker Systems

EP925 Series Duplex^{us} Ceiling Loudspeaker Systems

Transformer Specifications

EP925-32T:

Frequency Response:
50 Hz to 15 kHz, +/-1 dB

Insertion Loss:
<0.5 dB

Primary Voltage:
70.7 Vrms

Secondary Impedance:
8 ohms

Primary Impedance and Power Drawn:

- 1,250 ohms / 4.0 watt
- 650 ohms / 8.0 watt
- 312 ohms / 16.0 watt
- 156 ohms / 32.0 watt

EP925-60T:

Frequency Response:
60 Hz to 10 kHz, +/-1 dB

Insertion Loss:
<0.5 dB

Primary Voltage:
70.7 Vrms

Secondary Impedance:
8-16 ohms

Primary Impedance and Power Drawn:

- 667 ohms / 7.5 watt
- 333 ohms / 15.0 watt
- 166 ohms / 30.0 watt
- 83 ohms / 60.0 watt

EP925-100T:

Frequency Response:
20 Hz to 20 kHz, +/-1 dB

Insertion Loss:
<0.5 dB

Primary Voltage:
70.7 Vrms

Secondary Impedance:
8-16 ohms

Primary Impedance and Power Drawn:

- 99 ohms / 50.0 watt
- 71 ohms / 70.0 watt
- 50 ohms / 100 watt
- 36 ohms / 140 watt
- 25 ohms / 200 watt

Versions:

EP925-8B
EP925-32T
EP925-60T
EP925-100T

NOTES ON MEASUREMENT CONDITIONS

1. Pink-noise signal, one watt calculated using E^2/Z_{min} , 3.16-meter measurement distance referred to one meter.

2. On axis, one watt calculated using E^2/Z_{min} , 3.16-meter measurement distance referred to one meter, low frequencies corrected for anechoic-chamber error.

3. This system rating patterned after the ANSI/EIA RS-426-A method where the test signal is pink noise with a 6-dB crest factor over the bandwidth of the system, with power calculated using $E^2/R_E \times 1.15$, for 24 hours.

4. This measurement made under the same conditions as pressure sensitivity, but at rated power and takes into account any power-compression effects due to nonlinearities in the system.

5. Distortion components invalid above 10 kHz. The distortion at any given frequency may be found by graphically taking the difference between the fundamental and harmonic and adding the number of decibels which the harmonic has been raised on the graph and apply the formula:

$$\text{percent distortion} = 100 \times 10^{(-\text{difference in dB}/20)}$$

6. This measurement made with a nontransformer 3.0 cubic foot system vented enclosure.



600 Cecil Street, Buchanan, MI 49107
Phone: 616/695-6831, FAX: 616/695-1304