

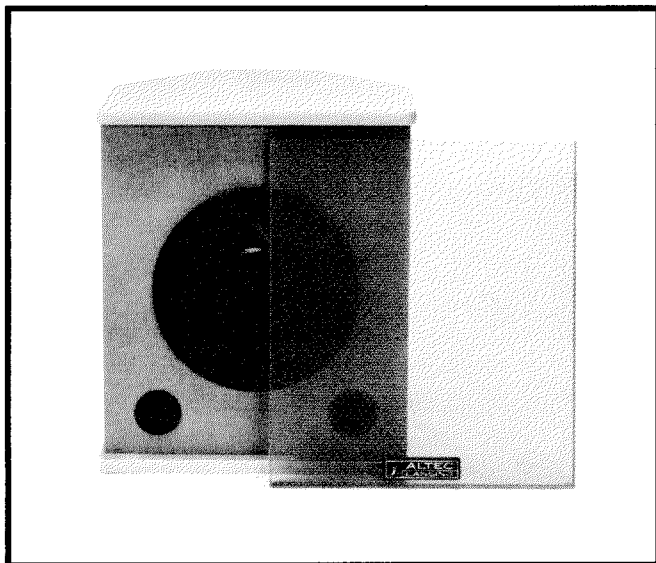

# 9820-8B 12" Duplex® Loudspeaker System



## KEY FEATURES

- ★ Medium-Output Capability
- ★ Auto-Reset Circuit Breaker
- ★ Enclosure Allows Refinishing
- ★ Unique 5-Sided Enclosure

## PRIMARY SPECIFICATIONS

<b>System Type:</b>	Two-way, vented-type full-range loudspeaker system.
<b>Pressure Sensitivity:</b> (1 W, 50 Hz to 15 kHz, re: 20 $\mu$ Pa, see note 1)	97.0 dB SPL.
<b>Frequency Response:</b> (see Figure 1, note 2)	50 Hz to 15 kHz.
<b>Power Handling:</b> (50 Hz to 15 kHz, see note 3)	125 watts, AES method. 250 watts, continuous program. 500 watts, peak power.
<b>Maximum Output:</b> (see note 4)	117 dB SPL, AES method. 120 dB SPL, continuous program. 123 dB SPL, peak power.
<b>Impedance:</b>	5.2 ohms minimum. 8.0 ohms nominal.

## DESCRIPTION

The Altec Lansing **9820-8B** loudspeaker is a two-way, factory assembled system capable of producing medium to high acoustic output from a small package. It is well suited for medium to high level sound reproduction in houses of worship, audio-visual presentations, conference rooms or other smaller acoustic environments. The **9820-8B** utilizes a 12.0 inch (30.5 cm) Duplex® loudspeaker with a wide dispersion dome tweeter. Smooth transition at crossover is accomplished by a dual-section 12 dB/octave network with a center frequency of 1.5 kHz. The **9820-8B** is also fully protected by means of an auto-reset circuit breaker at the input of the system which will not allow the inexperienced operator to damage the system's components. The enclosure is

constructed of 0.75 inch (1.9 cm) Enviro-board™ covered in a new and unique wood-grained vinyl which can be painted or stained to complement any interior. The enclosure is also supplied with a removable metal grille which is fastened to the front of the enclosure with four wood screws. Because of its compact size and unique cabinet design, it allows for easy and creative positioning to optimize sound dispersion patterns in difficult rooms. In addition, convenient tee-nut mounting points are provided to aid in hanging the system in a permanent installation.

The intended use of the **9820-8B** is in a small main sound reinforcement system or as a floor monitor in portable or fixed installations.

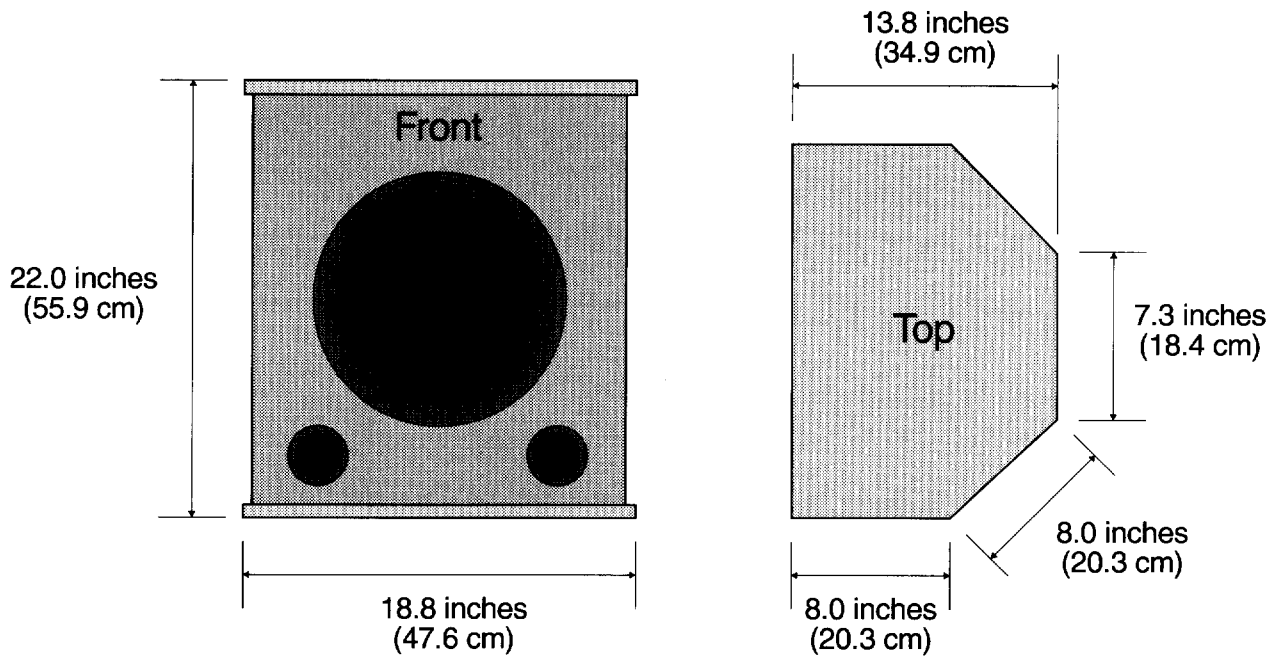

## 9820-8B SPECIFICATIONS (continued)

<b>Components:</b>	12.0 inch (30.5 cm) duplex® loudspeaker with a wide-dispersion dome tweeter.	<b>Finish:</b>	Acousta-beige wood-grained vinyl with beige metal grille.
<b>Crossover Network:</b>	Two-way at 1500 Hz with a 12 dB per octave slope for both sections.	<b>Dimensions:</b>	
<b>Input Terminals:</b>	Two 1/4 inch phone jacks and screw terminals.	Height:	22.0 in (55.9 cm).
<b>Replacement H.F. Diaphragm:</b>	25456.	Width:	18.8 in (47.6 cm).
<b>Replacement L.F. Recone Kit:</b>	R920-8B.	Depth:	13.8 in (34.9 cm).
<b>Replacement Grille:</b>	Model RG9820B.	<b>Weight:</b>	
<b>Enclosure:</b>	Vented-type, built of 0.75 inch (1.9 cm) Enviro-board™ lined with glass wool.	Net:	44.0 lbs (20.0 kg).
		Shipping:	50.0 lbs (22.7 kg).
		<b>Accessories:</b>	Altec Lansing AMK-1 stand mount kit.

Altec Lansing continually strives to improve products and performance. Therefore, specifications are subject to change without notice.

## NOTES ON MEASUREMENT CONDITIONS

1. Pink noise signal, one Watt calculated using  $E^2/Z_{min}$ , 3.16 meter measurement distance referred to one meter.
2. On-axis, one Watt calculated using  $E^2/Z_{min}$ , 3.16 meter measurement distance referred to one meter, low frequencies corrected for anechoic chamber error.
3. This system rating patterned after the AES method for individual driver, where the test signal is pink noise with a 6 dB crest factor over the bandwidth of the system, with power calculated using the  $E^2/Z_{min}$ , for two hours.
4. This measurement made under the same conditions as Pressure Sensitivity, but at rated power, and takes into account any power compression effects due to non-linearities in the system.
5. Distortion components invalid above 10 kHz. The distortion at any given frequency may be found by graphically taking the difference between the fundamental and harmonic, and adding the number of Decibels which the harmonic has been raised on the graph and apply the formula:

$$\% \text{ distortion} = 100 \times 10^{(\text{difference in dB} / 20)}$$

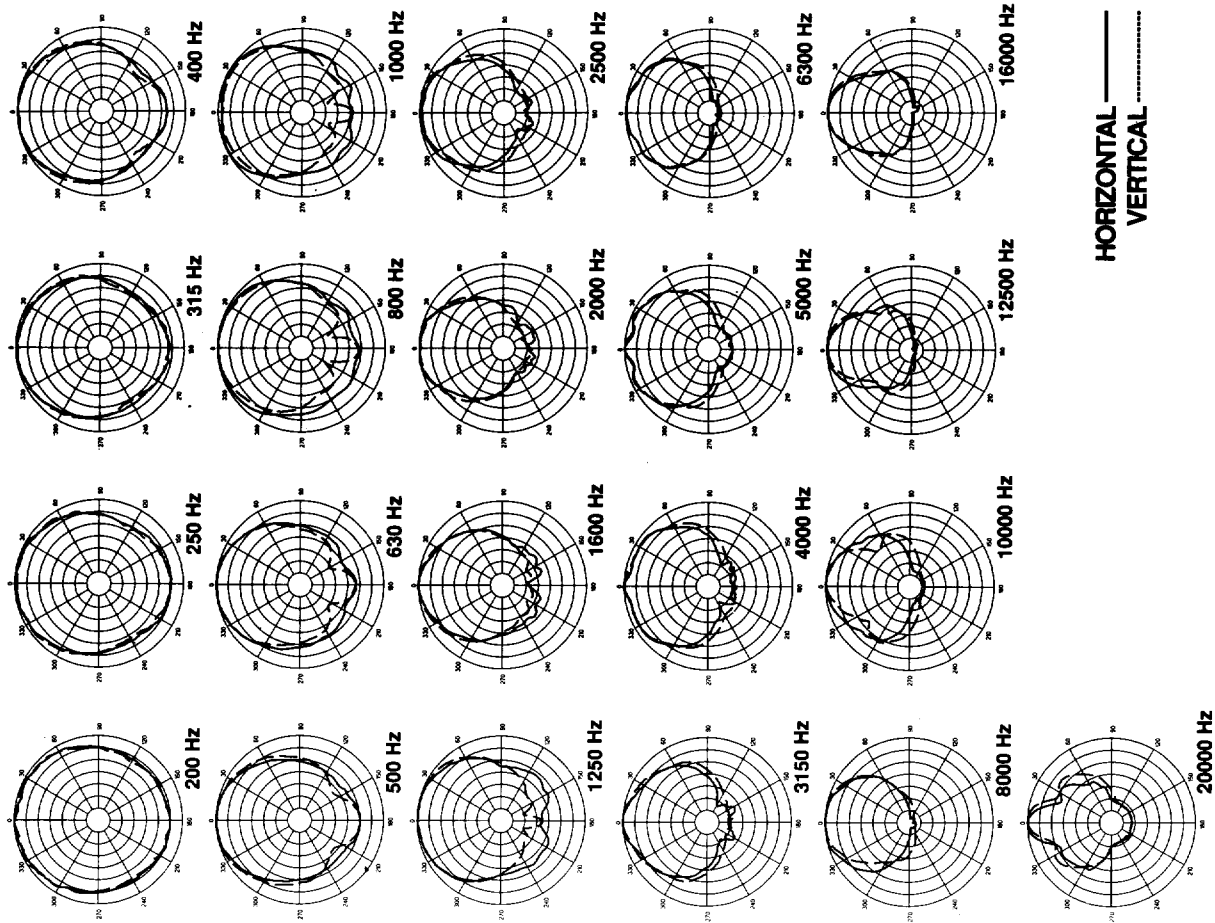

Figure 1 1/3-Octave Polar Response

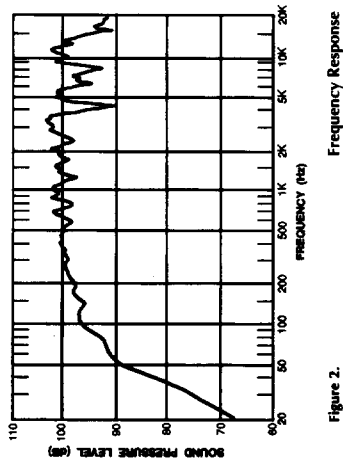

Figure 2. Frequency Response

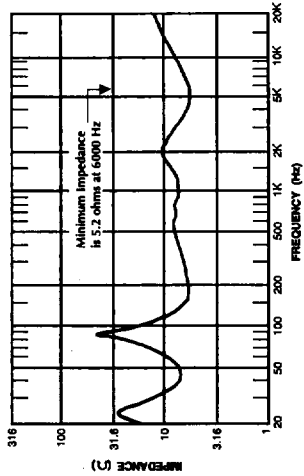

Figure 3. Dispersion Angle

Figure 4. Magnitude of Impedance

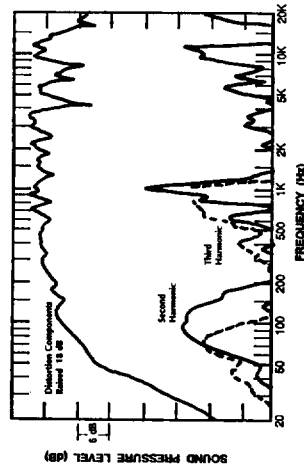

Figure 5. Q and Directivity Index

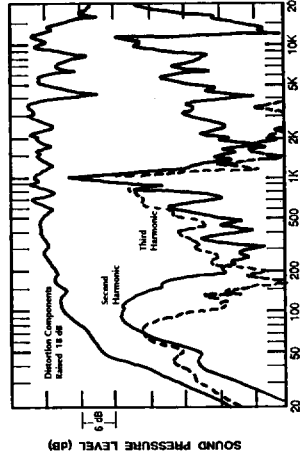

Figure 6. Harmonic Distortion at 0.01 Rated Power

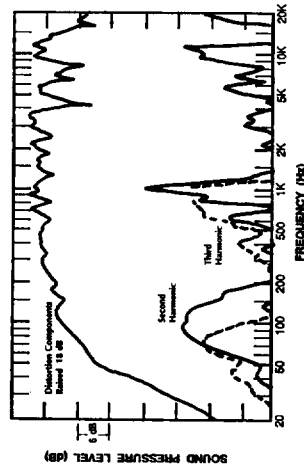
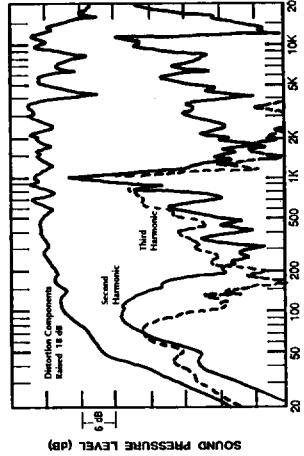

Figure 7. Harmonic Distortion at 0.1 Rated Power



(Horizontal)  
**Center of Gravity**

A: 6.5 inches (16.5 cm)

B: 9.5 inches (24.1 cm)

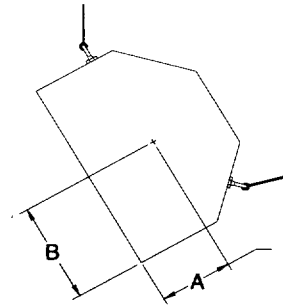
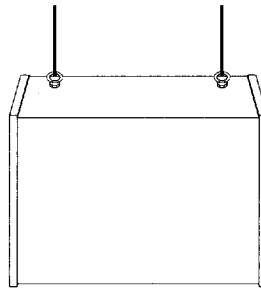

(Vertical)  
**Center of Gravity**

A: 6.5 inches (16.5 cm)

B: 11.0 inches (27.9 cm)

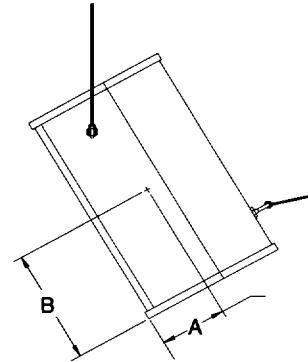
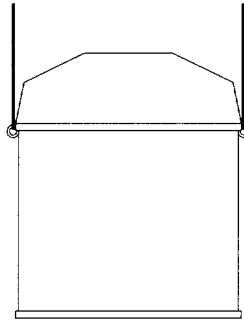

---

---

## ARCHITECT'S AND ENGINEERS SPECIFICATIONS

The loudspeaker system shall be a two-way multi-purpose type consisting of a 12.0 inch (30.5 cm) duplex® loudspeaker with a wide-dispersion dome radiator tweeter. The dividing network is a dual-section type 12 db/octave slope on both L.F. and H.F. sections with a crossover center frequency of 1.5 kHz. The loudspeaker system shall meet the following performance criteria: Power handling, 125 watts of pink noise with 6 dB crest factor, band limited from 50 Hz to 15 kHz. Frequency response, smooth and uniformly usable from 50 Hz to 15 kHz. Pressure sensitivity, 97 dB SPL when measured at one meter on axis with

one watt of band-limited pink noise from 50 Hz to 15 kHz. Minimum impedance, 5.2 ohms.

The enclosure shall be of the ported-type, constructed of 0.75 inch (1.9 cm) Enviro-board™ lined with sound-absorbent glass wool. The finish shall be a beige wood-grained vinyl that is paintable or stainable and shall have a beige metal grille. The dimensions shall be 22.0 inches (55.9 cm) high by 18.8 inches (47.6 cm) wide by 13.8 inches (34.9 cm) deep. The loudspeaker shall weigh 44.0 lbs. (20.0 kg)

The loudspeaker system shall be the Altec Lansing 9820-8B.



a MARK IV company

P.O. BOX 26105 • OKLAHOMA CITY, OK 73126-0105 • U.S.A.

Phone: 405/324-5311 or FAX: 405/324-8981

© 1994 ALTEC LANSING CORPORATION