

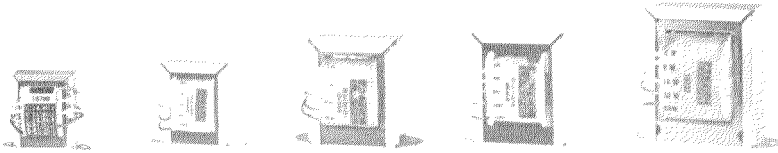

a Mark IV company

70.7/25-Volt Line Transformers



Description

Altec 70.7 V and 25 V Line Transformers are designed for use in distributed sound systems. In installations where loudspeakers are positioned some distance from the amplifier, more efficiency and less loss may be obtained when a high-impedance transmission line or 70.7/25 V constant voltage line is used. With the high-impedance distribution system, line matching transformers are necessary to match the impedance of the loudspeaker to the impedance of the line. The constant voltage line provides simple means of matching a number of loudspeakers to an amplifier. For these reasons, Altec Lansing has designed the most efficient transfer of power from the line to the loudspeaker.

Primary and secondary windings are electrically isolated, and provide a balanced line to

the load. Low insertion loss, low distortion and high efficiency are maintained throughout the frequency range, at full rated power output.

The Model 15704, 15708, 15716 and 15732 are 70.7 V line matching transformers with four selectable power taps. Selectable line loss correction taps are provided to compensate line resistance, allowing significant savings in wire gauge¹.

Primary taps of the line matching transformers are identified in watts for amplifier connections, with color coded lead wires. The 8-ohm secondary taps are 0.25-inch blade type quick-connect wire terminals, allowing either wrap-and-solder connections, or crimp type quick-connect wire terminals for convenience of installation.

¹Technical Letter No. 265A, Altec Lansing, Transmission Loss in 70.7 V and 25 V Lines.

Architects' and Engineers' Specifications

NOTE: After selecting the transformer, ascertain proper values given in the Table of Specifications, and insert values in blank spaces below.

The transformer shall deliver within dB of its full rated power over the frequency range of _____ Hz with a maximum insertion loss not greater than _____ dB for the most unfavorable impedance combination. The primary taps shall be identified with _____ W of audio power delivered to the load when the transformer is connected to a _____ volt line. The secondary taps shall be identified with a line loss correction of _____ dB, and an impedance of 8 ohms.

The transformer shall be the Altec Model _____.

Specifications 70.7/25 V Line Transformers

70.7/25-Volt Line Transformers

Specifications

70.7/25V LINE TRANSFORMERS

MODEL NUMBER	FREQUENCY RESPONSE (+1 dB)	INSERTION LOSS (max. dB)	PRIMARY VOLTAGE (Vrms)	PRIMARY IMPEDANCE (ohms)	PRIMARY POWER (watts)	SECONDARY IMPEDANCE (ohms)	SECONDARY POWER (watts)	LINE LOSS CORRECTION TAP (dB)
15700	100 Hz to 10 KHz	1.0	25 to 70.7	9997*	0.5	8	4	N/A
				4999*	1.0		4	
				2499*	2.0		4	
				1250*	4.0		4	
15704	50 Hz to 15 kHz	0.5	70.7	9997	0.5	8	4	0.5 to 1.0
				4999	1.0		4	
				2499	2.0		4	
				1250	4.0		4	
15708	50 Hz to 15 kHz	0.5	70.7	4999	1.0	8	8	0.5 to 1.0
				2499	2.0		8	
				1250	4.0		8	
				625	8.0		8	
15716	50 Hz to 15 kHz	0.5	70.7	2499	2.0	8	16	0.5 to 1.0
				1250	4.0		16	
				650	8.0		16	
				312	16.0		16	
15732	50 Hz to 15 kHz	0.5	70.7	1250	4.0	8	32	0.5 to 1.0
				650	8.0		32	
				312	16.0		32	
				156	32.0		32	

*For primary impedance at 25 V rms, divide by 8

Dimensions and Weight

MODEL NUMBER	A	B	C	D
15700	1.75"	1.38"	0.56"	1.81"
15704	2.00"	1.63"	0.69"	2.00"
15708	2.38"	2.00"	0.75"	2.38"
15716	2.75"	2.31"	0.81"	2.75"
15732	3.13"	2.56"	1.06"	3.13"

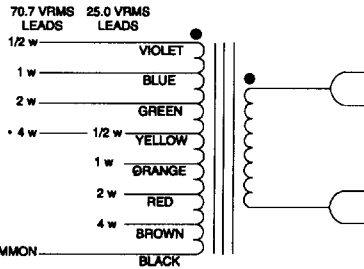
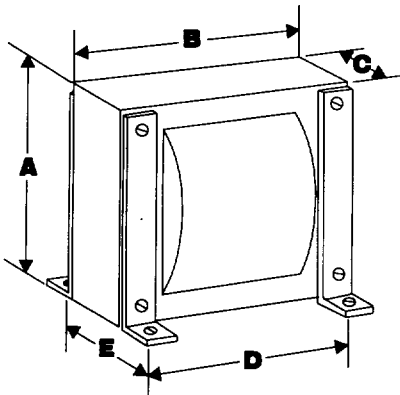

* The yellow and black leads are used for either 70 or 25 volt application.

15700

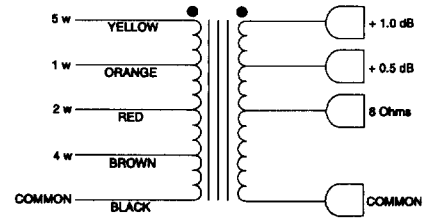

15704

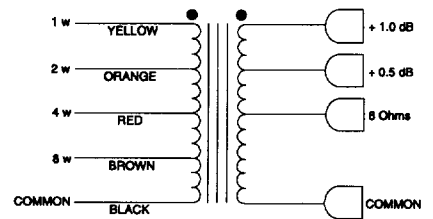

15708

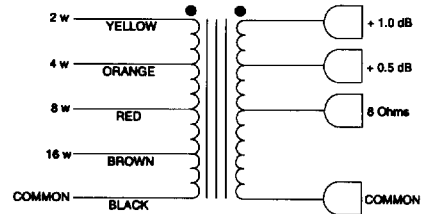

15716

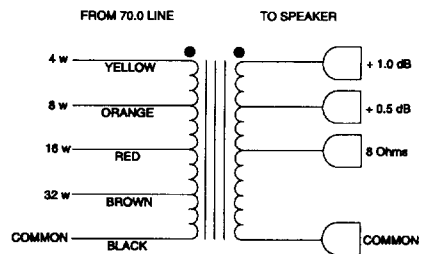

15732



a Mark IV company

600 Cecil Street, Buchanan, MI 49107
800/234-6831, 616/695-6831, 616/695-1304 Fax

Part Number 533452-9643