

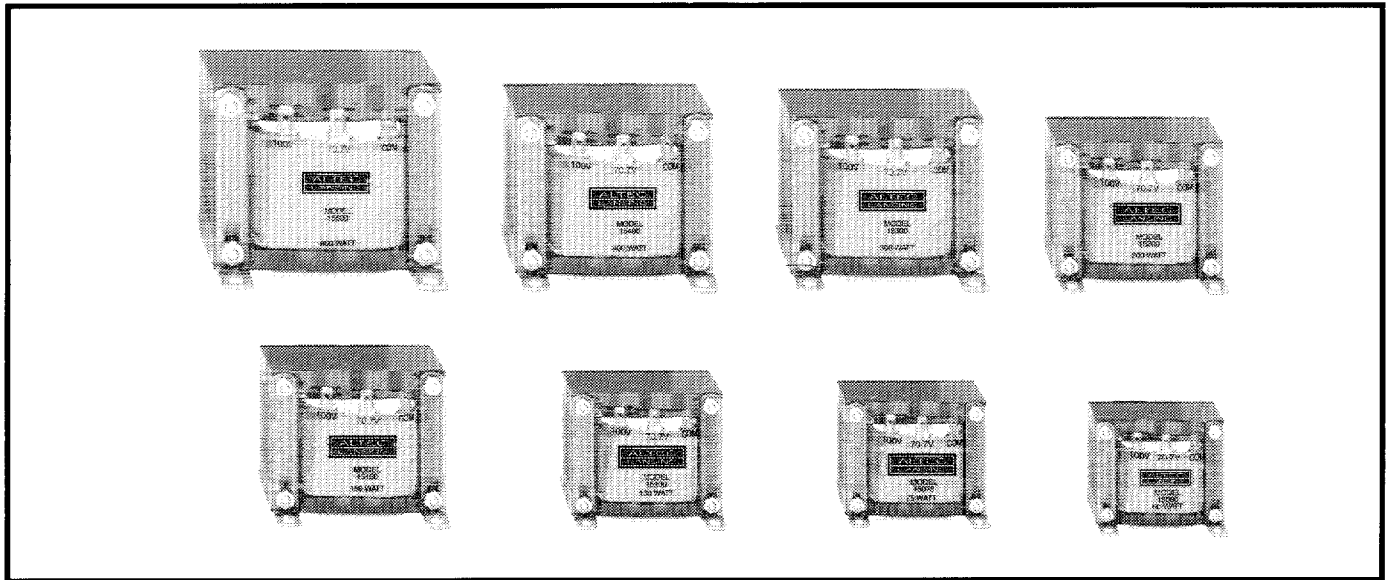

Premium Output Transformers

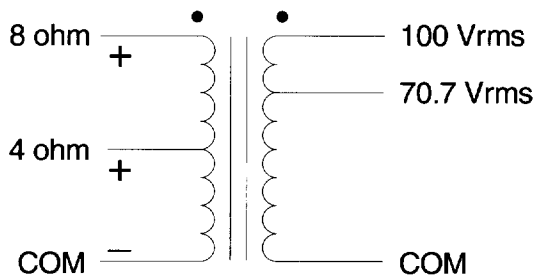

SCHEMATIC



KEY SPECIFICATIONS

Frequency Response:	35 Hz to 15 kHz, ± 1 dB.
Insertion Loss:	<1 dB from 35 Hz to 15 kHz.
Total Harmonic Distortion:	<1% at Rated Power. (35 Hz to 15 kHz)
Hi-Pot:	500 Vac.

DESCRIPTION

Altec Lansing 70.7V/100V Output Transformers are designed for efficient transmission of amplifier power to distributed sound systems or multiple loudspeakers. The transformers accommodate a wide range of user requirements for impedance matching, output voltage and power. Transformers are reflective devices and will deliver a ratio of the voltage applied to the primary, or reflect a ratio of the secondary load. Voltage and Impedance ratios are listed in Table I. The primary and secondary windings are reversible. Each model can be used to step-up or step-down.

Primary and secondary windings are electrically isolated, so that the transformer offers a balanced load to the amplifier and a balanced source to the loudspeakers. Low insertion loss,

low distortion and high efficiency are maintained throughout the dynamic range of each transformer and throughout the frequency band of 35 Hz to 15,000 Hz. The transformers have an insertion loss of no more than 1.0 dB and draw that much extra power from the amplifier to supply rated power to the load. All transformer terminals are 0.25-inch blade type quick-disconnect wire terminals allowing either wrap-and-solder connections or crimp type quick-connect wire terminals for convenience of installation. Terminals are identified by optimum application for rated power at 35 Hz.

Altec Lansing's 70.7V/100V Output transformers are amplifier accessories that increase flexibility and utility of any power amplifier.

KEY SPECIFICATIONS	15060	15075	15100	15150	15200	15300	15400	15600
Power Handling:	60 watt	75 watt	100 watt	150 watt	200 watt	300 watt	400 watt	600 watt
Voltage Ratio:								
4 ohm to 70V:	1:4.5	1:4.0	1:3.5	1:2.8	1:2.5	1:2.0	1:1.7	1:1.4
4 ohm to 100V:	1:6.4	1:5.7	1:5.0	1:4.1	1:3.6	1:2.8	1:2.5	1:2.0
8 ohm to 70V:	1:3.2	1:2.9	1:2.5	1:2.0	1:1.8	1:1.4	1:1.2	1:1.0
8 ohm to 100V:	1:4.6	1:4.1	1:3.6	1:2.9	1:2.5	1:2.0	1:1.8	1:1.5
4/8 term. to 70V:	1:10.9	1:9.8	1:8.5	1:7.0	1:6.0	1:4.9	1:4.0	1:3.5
4/8 term. to 100V:	1:15.4	1:13.9	1:12.0	1:9.8	1:8.5	1:7.0	1:5.7	1:4.9
Impedance Ratio:								
4 ohm to 70V:	1:22.5	1:17.5	1:13.7	1:8.8	1:6.7	1:4.5	1:3.1	1:2.2
4 ohm to 100V:	1:44.1	1:34.7	1:27.4	1:17.7	1:13.7	1:8.9	1:6.3	1:4.3
8 ohm to 70V:	1:11.0	1:8.9	1:6.7	1:4.4	1:3.3	1:2.2	1:1.6	1:1.1
8 ohm to 100V:	1:22.0	1:17.5	1:13.6	1:8.8	1:6.7	1:4.5	1:3.1	1:2.2
4/8 term. to 70V:	1:21.9	1:18.2	1:13.1	1:8.7	1:6.5	1:4.5	1:3.0	1:2.4
4/8 term. to 100V:	1:44.0	1:35.5	1:27.0	1:17.6	1:13.0	1:9.1	1:6.1	1:4.5
Primary Voltage (Vrms):								
4 ohm input:	15.5	17.3	20	24.5	28.3	34.6	40	49
8 ohm input:	21.9	24.5	28.3	34.6	40	49	56.6	69.3
Secondary Loading (ohms):								
70.7V output:	83.3	67	50	33.3	25	16.7	12.5	8.3
100V output:	167	167	100	67	50	33.3	25	16.7

Table I: Key Specifications of Premium Output Transformers

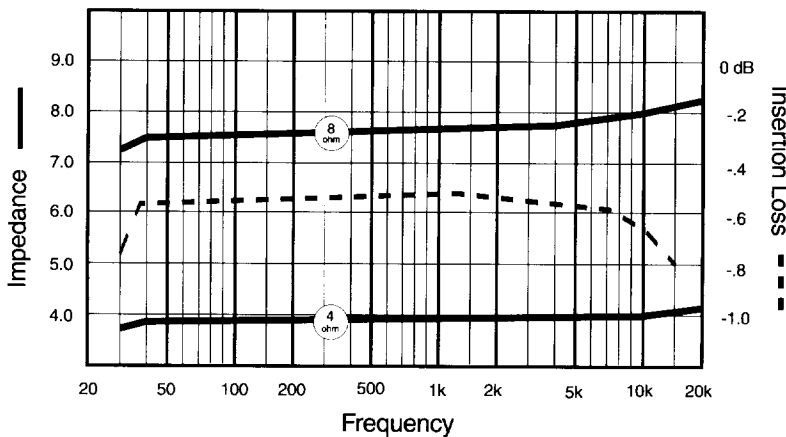

Figure 1: Typical Impedance And Insertion Loss

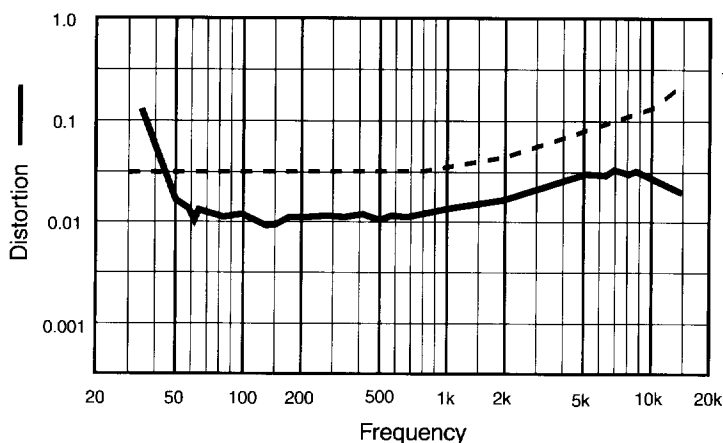
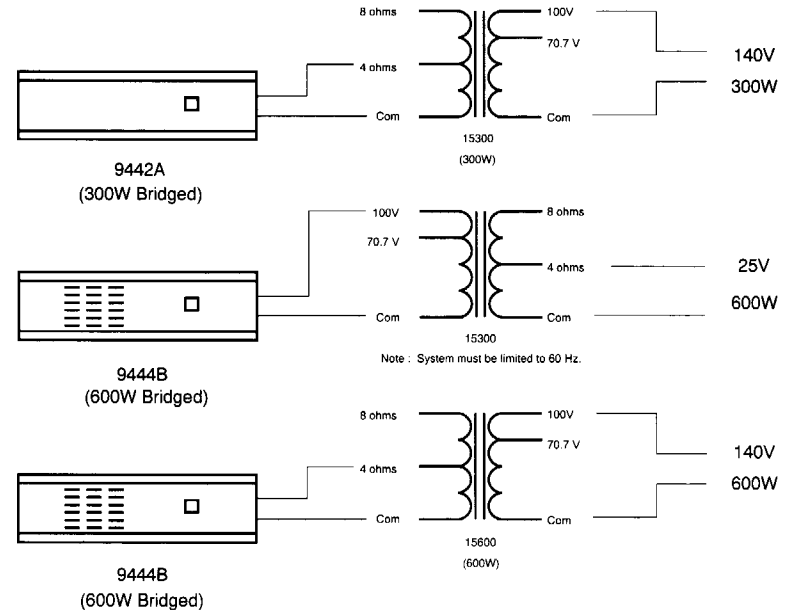
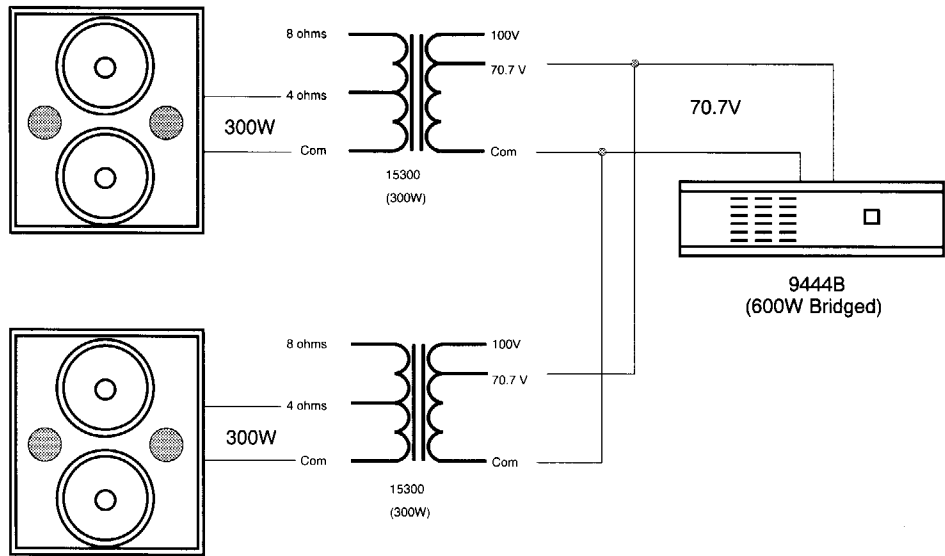
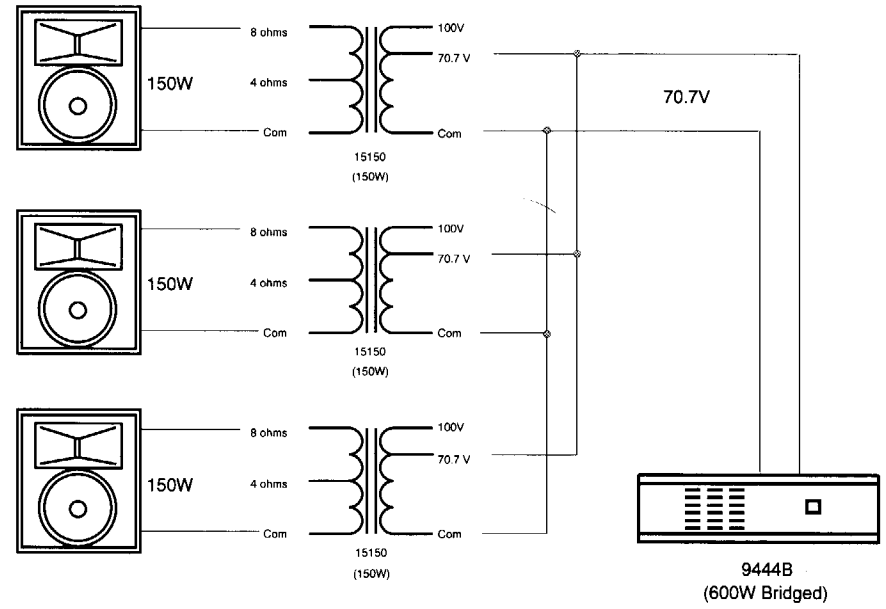
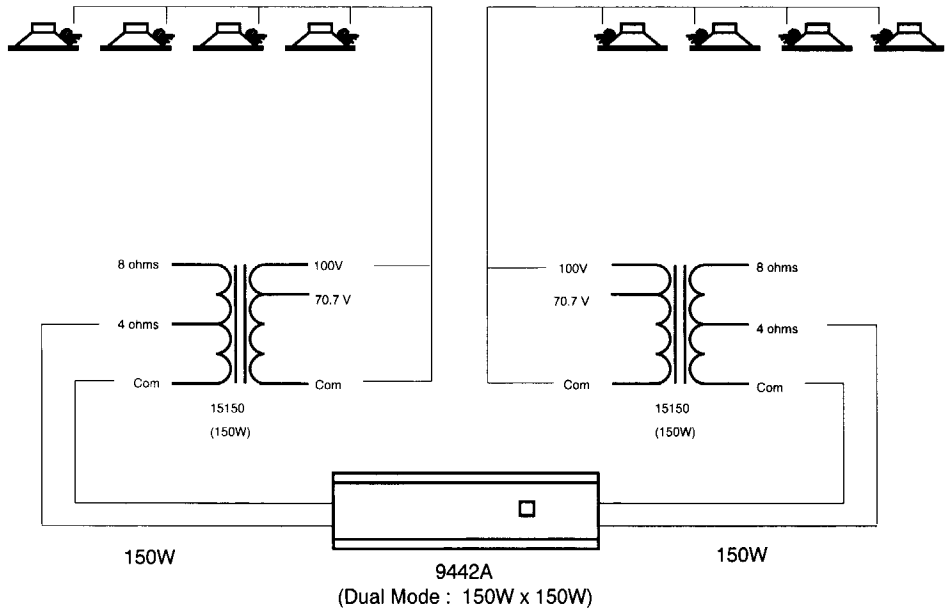
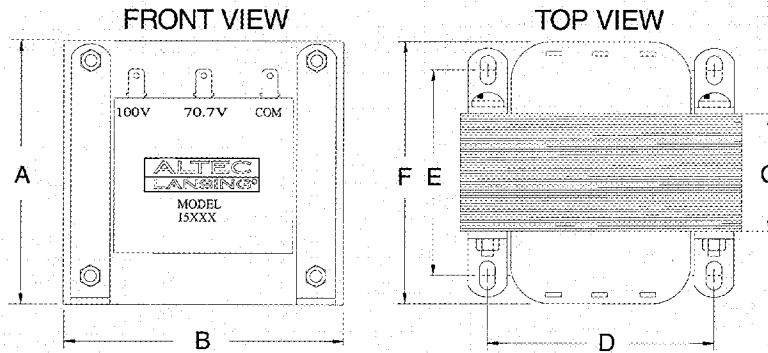

Figure 2: Typical Distortion And Phase Performance

Transformer response at low frequencies is limited by core saturation. A clear indication of core saturation is a sudden drop in primary impedance. Figure 1 shows the typical Altec 15000-Series Output Transformer has flat primary impedance to 35 Hz. Restricting the 15000-Series Output Transformer to above 60 Hz will effectively double the transformer's power handling. Insertion Loss is the difference between power applied to the primary and power available on the secondary. Figure 1 also shows the typical Insertion Loss of the 15000-Series Output Transformer is 0.5 dB. Distortion and Phase Response are shown in Figure 2. Distortion is excellent and remains well below 0.1%. Phase response is less than 9 degrees at 15 kHz.

RECOMMENDED APPLICATIONS FOR OUTPUT TRANSFORMERS





Model Number	A	B	C	D	E	F	Mounting Holes	Net Weight	Shipping Weight
15060	2.84 in	3.38 in	1.63 in	2.81 in	2.63 in	3.63 in	0.19 in	4.26 lbs	6.0 lbs
	7.21 cm	8.59 cm	4.14 cm	7.14 cm	6.68 cm	9.22 cm	0.48 cm	1.93 kg	2.72 kg
15075	3.12 in	3.75 in	1.50 in	3.12 in	2.50 in	3.50 in	0.19 in	4.91 lbs	6.5 lbs
	7.92 cm	9.53 cm	3.81 cm	7.92 cm	6.35 cm	8.89 cm	0.48 cm	2.23 kg	2.95 kg
15100	3.45 in	4.12 in	1.75 in	3.44 in	2.75 in	3.88 in	0.19 in	6.71 lbs	8.0 lbs
	8.76 cm	10.46 cm	4.45 cm	8.74 cm	6.99 cm	9.86 cm	0.48 cm	3.04 kg	3.63 kg
15150	3.75 in	4.50 in	1.75 in	3.75 in	2.75 in	4.00 in	0.19 in	8.06 lbs	9.5 lbs
	9.53 cm	11.43 cm	4.45 cm	9.53 cm	6.99 cm	10.16 cm	0.48 cm	3.66 kg	4.31 kg
15200	3.75 in	4.50 in	2.00 in	3.75 in	3.00 in	4.00 in	0.19 in	8.98 lbs	10.5 lbs
	9.53 cm	11.43 cm	5.08 cm	9.53 cm	7.62 cm	10.16 cm	0.48 cm	4.07 kg	4.76 kg
15300	4.38 in	5.25 in	1.97 in	4.32 in	3.12 in	4.00 in	0.19 in	11.92 lbs	14.5 lbs
	11.13 cm	13.34 cm	5.00 cm	10.97 cm	7.92 cm	10.16 cm	0.48 cm	5.41 kg	6.58 kg
15400	5.38 in	6.38 in	2.51 in	5.30 in	3.63 in	5.50 in	0.25 in	17.35 lbs	20.0 lbs
	13.67 cm	16.21 cm	6.38 cm	13.46 cm	9.22 cm	13.97 cm	0.64 cm	7.87 kg	9.07 kg
15600	5.06 in	6.00 in	3.06 in	4.95 in	4.12 in	5.12 in	0.25 in	23.67 lbs	27.0 lbs
	12.85 cm	15.24 cm	7.77 cm	12.57 cm	10.46 cm	13.00 cm	0.64 cm	10.74 kg	12.25 kg

Table II: Dimensions And Weights Of The Premium Output Transformers

ARCHITECT'S and ENGINEER'S SPECIFICATIONS

The transformer shall deliver within ± 1.0 dB of its full rated power over the frequency range of 35 Hz to 15,000 Hz with a maximum insertion loss not greater than 1.0 dB for the most unfavorable impedance combination. The transformer shall deliver rated power at 35 Hz with no more than a 10% increase of power on the primary.

Primary and secondary windings shall be electrically isolated, and shall provide a balanced line to the load. The transformer shall utilize 0.25-inch blade quick-connectors for convenience of installation and wiring. The transformer shall be the ALTEC LANSING Model _____.



a MARK IV company

P.O. BOX 26105 • OKLAHOMA CITY, OK 73126-0105 • U.S.A.

Phone: 405/324-5311 or FAX: 405/324-8981

© 1994 ALTEC LANSING CORPORATION