

Model 313

Shock-Mount Microphone Clamp



- Provides excellent shock isolation for microphones with $\frac{3}{4}$ -inch diameter barrels
- Designed for use with any microphone stand, podium, fishpole or boom that uses a $\frac{5}{8}$ -27 thread
- Versatile side-latch makes access to microphone quick and easy, or theft-resistant when necessary.

Description

The Electro-Voice 313 shock-mount clamp is designed to provide shock isolation for any microphone having a 19-millimeter ($\frac{3}{4}$ -inch) barrel diameter. The 313 will also work with microphones slightly larger in diameter, but with reduced isolation. The design of the clamp allows a microphone to be placed in the clamp while still connected to its cable. A latch on the side of the clamp allows quick and easy access to the microphone. In installations where easy access to microphone is undesirable, a small screw provided with the clamp may be placed through the latch into the clamp to hamper removal of the microphone.

The open design of the 313 does not interfere with the frequency response or directional characteristics of microphones placed in the clamp.

The 313 may be used on microphone stands or podiums to provide shock isolation. It will also provide excellent shock isolation for small microphones used on fishpoles or booms.

The 313 may be used with any standard microphone stand using a $\frac{5}{8}$ -27 thread.

Replacement Parts

Should it become necessary to order replacement suspensory ligaments (shock cords Part No. 72448/black) new ones may be ordered directly from Electro-Voice, Inc., 600 Cecil Street, Buchanan, MI 49107, Attention: Miscellaneous Parts Department.

Specifications are subject to change without notice.

Limited Warranty

Electro-Voice products are guaranteed against malfunction due to defects in materials or workmanship for a specified period, as noted in the individual product-line statement(s) below, or in the individual product data sheet or owner's manual, beginning with the date of original purchase. If such malfunction occurs during the specified period, the product will be repaired or replaced (at our option) without charge. The product will be returned to the customer prepaid. **Exclusions and Limitations:** The Limited Warranty does not apply to: (a) exterior finish or appearance; (b) certain specific items described in the individual product-line statement(s) below, or in the individual prod-

uct data sheet or owner's manual; (c) malfunction resulting from use or operation of the product other than as specified in the product data sheet or owner's manual; (d) malfunction resulting from misuse or abuse of the product; or (e) malfunction occurring at any time after repairs have been made to the product by anyone other than Electro-Voice Service or any of its authorized service representatives. **Obtaining Warranty Service:** To obtain warranty service, a customer must deliver the product, prepaid, to Electro-Voice Service or any of its authorized service representatives together with proof of purchase of the product in the form of a bill of sale or receipted invoice. A list of authorized service representatives is available from Electro-Voice Service at 600 Cecil Street, Buchanan, MI 49107 (800/234-6831 or FAX 616/695-4743). **Incidental and Consequential Damages Excluded:** Product repair or replacement and return to the customer are the only remedies provided to the customer. Electro-Voice shall not be liable for any incidental or consequential damages including, without limitation, injury to persons or property or loss of use. Some states do not allow the exclusion or limitation of incidental or consequential damages so the above

Model 313/Shock-Mount Microphone Clip

limitation or exclusion may not apply to you. **Other Rights:** This warranty gives you specific legal rights, and you may also have other rights which vary from state to state. **Electro-Voice Accessories** are guaranteed against malfunction due to defects in materials or workmanship for a period of one (1) year from the date of original purchase. Additional details are included in the Uniform Limited Warranty statement.

For warranty repair or service information, contact the service repair department at: 616/695-6831 or 800/685-2606.

For technical assistance, contact Technical Support at 800/234-6831 or 616/695-6831, M-F, 8:00 a.m. to 5:00 p.m. Eastern Standard Time.

Specifications subject to change without notice.

Specifications

Material:

Steel and polycarbonate

Finish:

Nonreflecting black

Dimensions,

Length:

63.5 mm (2.50 in.)

Width:

34.0 mm (1.34 in.)

Height:

86.4 mm (3.40 in.)

Weight:

142 grams (5 oz)

Rotation:

180° swivel

FIGURE 1 — 313 Dimensions

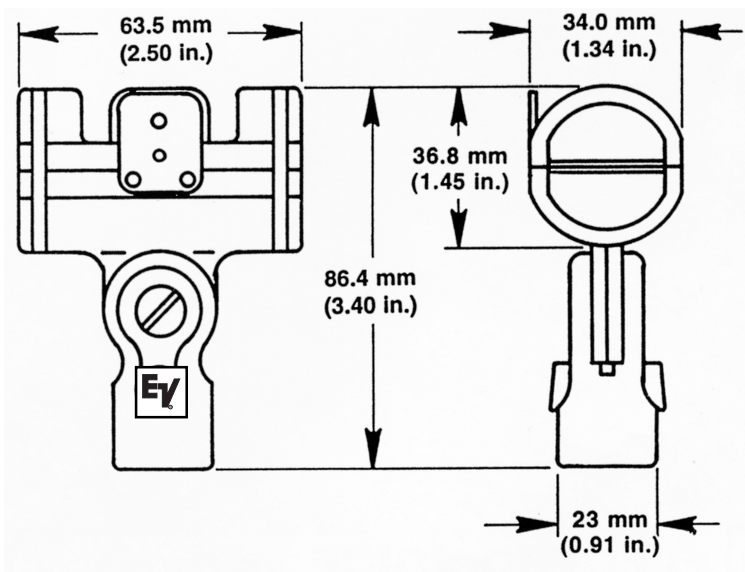

Model 313/Shock-Mount Microphone Clip

Electro-Voice®

600 Cecil Street, Buchanan, MI 49107
616/695-6831, 616/695-1304 Fax