



Model 309A

Suspension Shock Mount

- Specially designed for RE20 and RE27 N/D microphone
- Attaches to 5/8"–27 standard thread
- Used on booms and stands
- Safety bayonet locking action

Description and Applications

The Electro-Voice 309A suspension shock mount was designed specifically for use with the RE20 and RE27N/D dynamic microphones. It provides near-perfect shock isolation for the already internally shock-mounted RE20 or RE27N/D. For most applications, the Model 309A may be attached directly to the recording boom or to a floor stand. A stand adapter with $\frac{5}{8}$ " —27 thread is provided.

The 309A mount design allows quick installation of the RE20 or RE27N/D microphone without tools. A double safety factor is provided to ensure that the microphone will remain attached to the shock mount under any conditions. First, a "bayonet" locking action assures that the microphone will not fall out of the shock mount under its own weight. Additionally, a set screw (wing type) can be tightened to lock the microphone in place after it has been properly positioned.

Four molded neoprene shock cords suspend and support the microphone within an aluminum and steel frame-work to effectively isolate it from mechanical shock and vibration.

Replacement Parts

Should the rubber suspensory ligaments (shock cords) wear out through excessive use, deteriorate due to atmospheric conditions, or in any way change, new ones may be ordered from Electro-Voice, Inc., Buchanan, Michigan 49107. Attention: Miscellaneous Part Department. Request Part No. 78297. You will be billed for the cost.

Specifications subject to change without notice.

Limited Warranty

Electro-Voice products are guaranteed against malfunction due to defects in materials or workmanship for a specified period, as noted in the individual product-line statement(s) below, or in the individual product data sheet or owner's manual, beginning with the date of original purchase. If such malfunction occurs during the specified period, the product will be repaired or replaced (at our option) without charge. The product will be returned to the customer prepaid. **Exclusions and Limitations:** The Limited Warranty does not apply to: (a) exterior fin-

ish or appearance; (b) certain specific items described in the individual product-line statement(s) below, or in the individual product data sheet or owner's manual; (c) malfunction resulting from use or operation of the product other than as specified in the product data sheet or owner's manual; (d) malfunction resulting from misuse or abuse of the product; or (e) malfunction occurring at any time after repairs have been made to the product by anyone other than Electro-Voice Service or any of its authorized service representatives. **Obtaining Warranty Service:** To obtain warranty service, a customer must deliver the product, prepaid, to Electro-Voice Service or any of its authorized service representatives together with proof of purchase of the product in the form of a bill of sale or receipted invoice. A list of authorized service representatives is available from Electro-Voice Service at 600 Cecil Street, Buchanan, MI 49107 (800/234-6831 or FAX 616/695-4743). **Incidental and Consequential Damages Excluded:** Product repair or replacement and return to the customer are the only remedies provided to the customer. Electro-Voice shall not be liable for any incidental or consequential dam-

Model 309A/Suspension Shock Mount

Model 309A/Suspension Shock Mount

ages including, without limitation, injury to persons or property or loss of use. Some states do not allow the exclusion or limitation of incidental or consequential damages so the above limitation or exclusion may not apply to you. **Other Rights:** This warranty gives you specific legal rights, and you may also have other rights which vary from state to state.

Electro-Voice Accessories are guaranteed against malfunction due to defects in materials or workmanship for a period of one (1) year from the date of original purchase. Additional details are included in the Uniform Limited Warranty statement.

For warranty repair or service information, contact the service repair department at: 616/695-6831 or 800/685-2606.

For technical assistance, contact Technical Support at 800/234-6831 or 616/695-6831, M-F, 8:00 a.m. to 5:00 p.m. Eastern Standard Time.

Specifications subject to change without notice.

Specifications

Material:

Aluminum and Cycolac

Finish:

Black

Dimensions:

158.8 mm (6.25 in.) wide

155.6 mm (6.13 in.) deep

231.8 mm (9.13 in.) high

Weight:

312 grams (11 oz)

Suspension:

Four molded neoprene cords (E-V Part No. 78297)

Rotation:

360 degrees swivel

Accessories Provided:

$\frac{5}{8}$ " —27 stand adapter

FIGURE 1—Dimensions

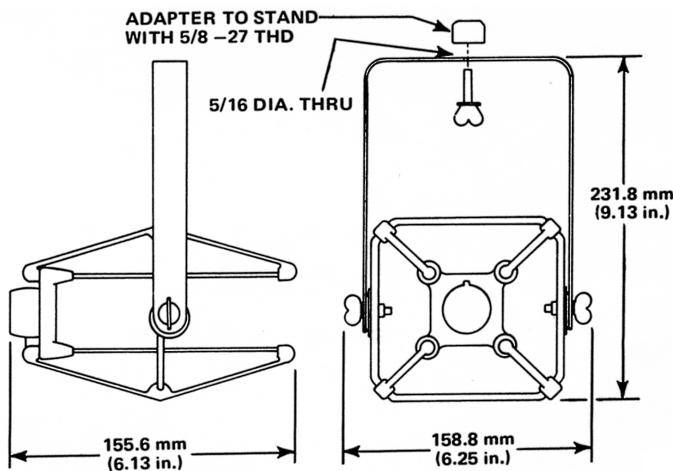

Electro-Voice®

600 Cecil Street, Buchanan, MI 49107

616/695-6831, 616/695-1304 Fax