

**Electro-Voice®**  
a MARK IV company

# Model 100BK Tripod Stand

## SPECIFICATIONS

### Height Range:

48 in. to 90 in.

### Riser Diameter:

1 3/8 in.

### Weight Limit:

38.6 kg (85 lb)

### Material:

Aluminum and steel

### Finish:

Matte-black paint

### Net Weight:

3.6 kg (8 lb)

### Shipping Weight:

4.1 kg (9 lb)

### Optional Accessory:

SMK-1 stand-mounting kit for SH-1502ER and SH-1512ER

## NOTE

Do not over tighten the levers, as this will result in undue stress on the fitting. Just tighten enough to hold its position firmly.

Raise the speaker up and then lower it onto the tripod upper tube. The top of the tripod can be lowered within easier reach by adjusting the leg spread to a smaller diameter. Leg spread can be readjusted after the equipment is mounted. Loosen the collar lever and raise the upper tube to the desired height setting; then retighten the lever snugly. There is a white arrow marking the last 6 inches. Do not extend it higher than this point.

## BREAKDOWN

Exercise extreme caution when loosening either lever while the tripod has a load on it. Lower the upper tube slowly until it bottoms out. Tighten the collar lever before attempting to lift the equipment off. Then loosen the leg fitting lever and return the legs to their folded positions.

## CARE

Treat the stand with the care that any fine instrument deserves. Dents in the lower or upper tube will hamper the telescoping action. A damp cloth or non-abrasive cleaner can be used to clean the stand.

## DESCRIPTION

The 100BK tripod stand is designed to support speaker systems weighing up to 85 lb. The speaker's stand-mounting inserts must have an inside diameter of 1 3/8 inches.

## SETTING UP

On removal from the box, first tighten the collar lever and loosen the leg fitting lever. Now turn the tripod upside down and pivot each leg outward enough to start sliding the leg fitting. Return the tripod to upright position and adjust the leg spread to the desired diameter by sliding the leg fitting. Be sure to tighten the lever on the leg fitting snugly after adjustment.

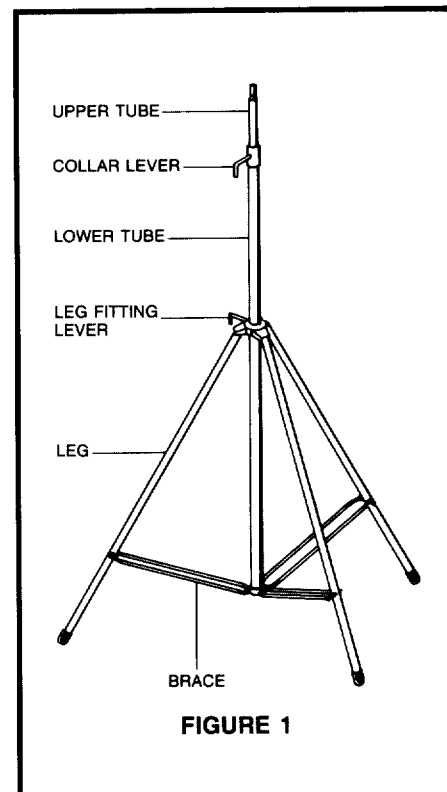

**FIGURE 1**

**WARRANTY (Limited)**

Electro-Voice Accessories are guaranteed for one year from date of original purchase against malfunction due to defects in workmanship and materials. If such malfunction occurs, unit will be repaired or replaced (at our option) without charge for materials or labor if delivered prepaid to the proper Electro-Voice service facility. Unit will be returned prepaid. Warranty does not extend to finish, appearance items or malfunction due to abuse or operation under other than specified conditions, nor does it extend to incidental or consequential damages. Some states do not allow the exclusion or limitation of incidental or consequential damages, so the above exclusion may not apply to you. Repair by other than Electro-Voice or its authorized warranty service agencies will void this guarantee. A list of authorized service centers is available from Electro-Voice, Inc., 600 Cecil Street, Buchanan, MI 49107 (AC/616-695-6831); or Electro-Voice West, 8234 Doe Avenue, Visalia, CA 93291 (AC/209-651-7777). This warranty gives you specific legal rights, and you may also have other rights which vary from state to state.

Service and repair address for this product:  
Electro-Voice, Inc., 600 Cecil Street,  
Buchanan, Michigan 49107.

Specifications subject to change  
without notice.



**ELECTRO-VOICE, INC., 600 Cecil Street, Buchanan, Michigan 49107**

MANUFACTURING PLANTS AT ■ BUCHANAN, MI ■ NEWPORT, TN ■ SEVIERVILLE, TN ■ OKLAHOMA CITY, OK ■ GANANOQUE, ONT.  
©Electro-Voice, Inc. 1990 ■ Litho in U.S.A. Part Number 530855—734

a MARK IV company