

8 Input 120 Watt MIXER-AMPLIFIER



Description

The AMIS120XL is an 8 channel, 120 watt mixer amplifier suitable for rack or desk mounting. The amplifier is a self contained compact unit of solid steel construction. This amplifier features a status LED.

Inputs

The AMIS120XL has eight universal input channels with separate level controls. Each channel will accept balanced or unbalanced microphone, line and auxiliary inputs. The unit has industry standard XLR microphone sockets and dual RCA auxiliary sockets for each channel. Rear panel dip switches per channel allow the adjustment of line input sensitivity. An insert point is also featured on the rear panel for those applications where an additional EQ or Feedback Exterminator may be required. An electronically-balanced 600 ohm telephone input for paging is also provided.

Outputs

The AMIS120XL features 70 volt, 4 & 8 ohm isolated transformer outputs, plus a tape recorder output by means of dual RCA sockets. A balanced 700mV XLR output is also provided to feed up to 6 power amplifiers. A vox triggered relay output is also available on the rear panel for activation of external devices from the vox muting circuit. In most cases this would be used as a muting bypass relay, which when used with the appropriate external attenuator will maintain paging levels irrespective of the attenuator setting.

VCA Control

The master volume level can be controlled remotely. External VCA control would normally be via a pot connected to a two wire rear panel barrier strip.

Tone Generator

The AMIS120XL comes standard with an in-built four tone generator module. Tones include Bell, Pre-announce Chime, Alert Tone and Evacuate Tone. Any of these tones may be activated from a simple contact closure connected to the rear panel of the amplifier.

Muting

Multiple levels of VOX muting is standard on the AMIS120XL. A mic or line signal on channels 1 will mute channels 2 to 8, on channel 2 will mute 3-8 and channel 3, will mute 4-8. The muting function can be disabled via an internal link. A vox triggered relay output is also available on the rear panel for activation of external devices from the vox muting circuit. In most cases this would be used as a muting bypass relay, which when used with the appropriate external attenuator will maintain paging levels irrespective of the attenuator setting.

SPECIFICATIONS

Power Output

120 watts RMS

Maximum Load

40 Ohms @ 70 Volts

Power Bandwidth

60Hz - 17kHz (- 3dB)

Frequency Response

60Hz - 23kHz (- 3dB)

Total Harmonic Distortion

0.5% @ 1kHz rated power

Signal To Noise Ratio

-74dB with all controls at center

Tone Controls

Bass @ 100Hz

Boost +12dB Cut -12dB

Mid @ 600Hz

Boost +12dB Cut -12dB

Treble @ 10kHz

Boost +9dB Cut -9dB

Inputs

Eight mic/aux universal inputs with XLR female and dual RCA plugs ; 600 ohm transformer balanced telephone paging input

Input Sensitivity

Mics: 1mV @ 200 Ohms

Aux: 150mV @ 47K Ohms

with 9, 12, 15dB Pads

Outputs

Speaker: 70 Volts, 4 & 8 Ohms

Tape: 350mV @ 10K Ohms

Line: Balanced 700mV

Phantom Power

18V DC on all Mic ins- Switch

Controls

8 Input channel gain controls

1 Bass control

1 Mid Control

1 Treble control

1 Master gain control

VCA rear panel strip

Dip Switch per Channel for line sensitivity and phantom power and a vox relay output

Tone Generators

Four tone generator with Bell,

Pre-Announce, Alert and Evac

Muting

Channel 1 will mute chans. 2 to 8, channel 2 mutes 3 - 8, channel 3 mutes 4 - 8. Also a vox relay to external devices.

Indicators

Power "on" & signal present LEDs

Dimensions:

3.5" H x 19" W x 13" D

Weight 26.5lb

AMIS 120XL



Phantom Power

Phantom Power (18 volts DC) is available from all mic inputs. A rear panel phantom power on/off dip switch is also provided per channel.

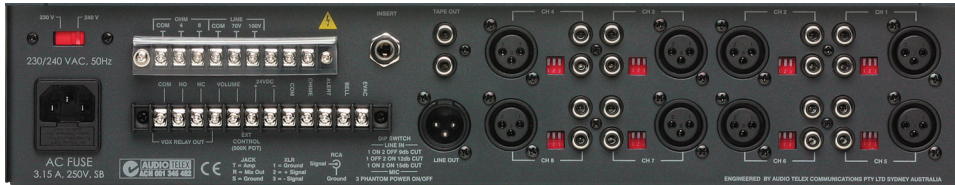

Protection

Internal current limiting protects the amplifier from both overload and overdrive conditions. Australian Monitor Installation Series amplifiers feature a protection network that provides greater stability and performance. Our amplifiers are recognised worldwide for their reliability and this is due to the extensive levels of current limiting which protect the amplifiers from both overload and overdrive conditions.

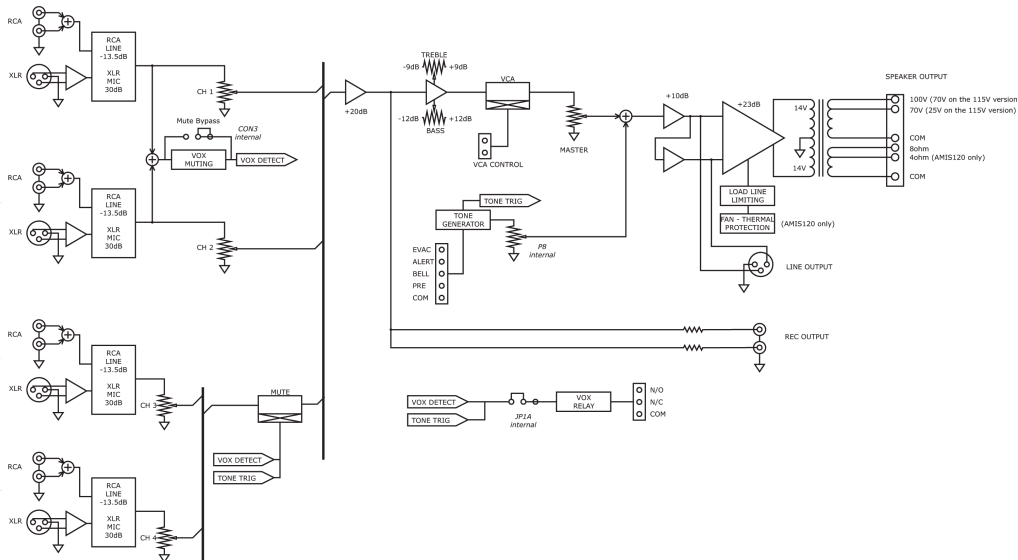

ABOUT

Australian Monitor Corporate Headquarters is located in Sydney, Australia. The organization has more than 20 years experience in the design and manufacture of audio amplifiers and associated products. They are a dynamic corporation, priding themselves on excellent customer service, better features and lower priced products for Sound Contractors and Audio Visual Integrators worldwide.

Architectural and Engineering Specifications

The mixer amplifier shall have eight universal input channels, each comprising of a balanced microphone input with XLR female sockets and an auxiliary input using dual RCA sockets. A balanced XLR output to drive additional power amplifiers shall also be provided. The master output may be controlled remotely via a VCA control. An insert point is provided for the addition of signal processing. A vox triggered relay output (for external devices) shall also be included. The amplifier master section shall include one master gain control, three EQ controls, one at 100Hz with 12dB of cut and boost, one at 600Hz with 12dB cut and boost and the other with 9dB of cut and boost at 10kHz. Speaker outputs shall be transformer isolated at 70 volt, 4 & 8 ohms. The amplifier must be capable of delivering 120 watts RMS into a 40 inductive ohm load, with less than 0.5% distortion measured at 1kHz and with system hum and noise equal to or better than -74dB. Power consumption shall be 120 watts at max power. The amplifier shall be an Australian Monitor Installation Series model AMIS120XL.