

ELiTE ProPanels™

PRODUCT DESCRIPTION

For the professional who requires an aesthetic acoustical treatment solution, ELiTE ProPanels cover the spectrum. These fabric-wrapped fiberglass based panels are available in any size up to 4'x10' and in thicknesses from .5" to 4". With multiple finish and mounting options, ProPanels can easily be implemented into practically any room. Choose from one of hundreds of different fabrics to perfectly match or compliment your interior environment.

APPLICATIONS

- Auditoriums, Theaters and Gymnasiums
- Classrooms and Lecture Halls
- Houses of Worship
- Board Rooms and Meeting Facilities
- Offices, Training Centers and Commercial Facilities
- Recording Studios and Audio Production Facilities

Product Overview

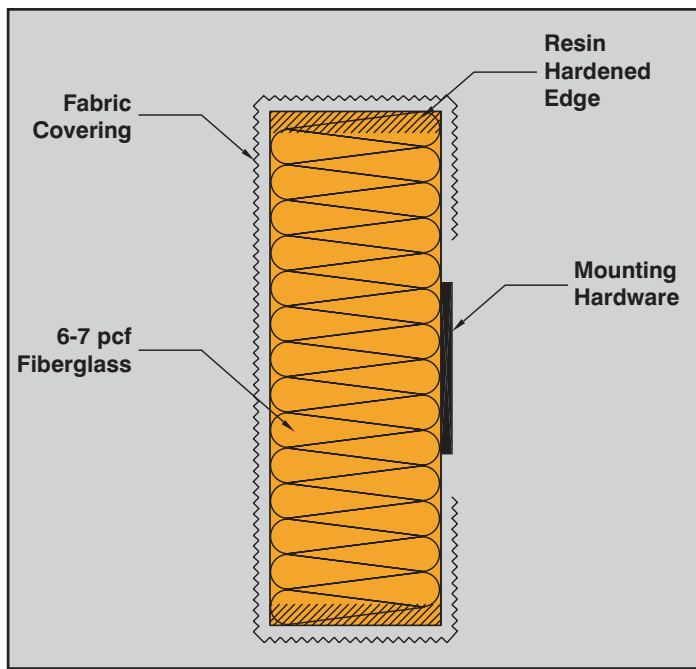

Custom Options

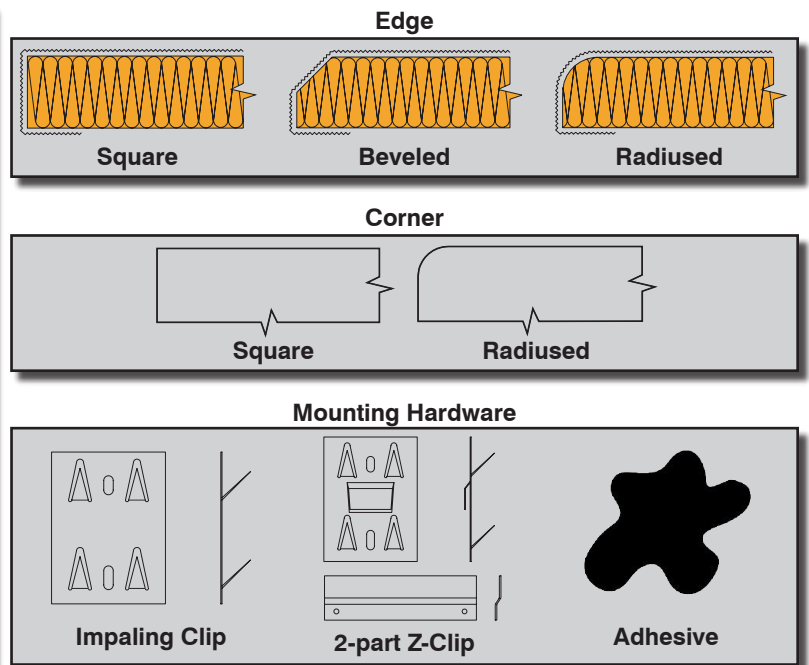

Test Data

		Center Frequency (Hz)						N.R.C.
		125	250	500	1000	2000	4000	
Thickness (in)	.5	0.07	0.09	0.35	0.77	0.98	1.03	0.55
	1	0.07	0.29	0.80	1.01	1.05	0.99	0.80
	2	0.42	0.89	1.12	1.07	1.10	1.09	1.05
	3	0.75	0.89	1.11	1.21	1.21	1.20	1.10
	4	0.87	0.87	1.24	1.26	1.26	1.25	1.15

*All tests independently conducted according to the standards of ASTM C423-90a.

Flammability: Each ProPanel component has a Class A flame rating per ASTM E84

Elegant. Accurate. Brilliant.™

Impact Resistant ELiTE ProPanels™

PRODUCT DESCRIPTION

ELiTE Impact Resistant ProPanels offer a high degree of durability even in harsh conditions through the implementation of an 18pcf fiberglass facing applied to the standard core. These panels are available in any size up to 4'x10' and in both 1" and 2" thicknesses. There are hundreds of different fabric styles and colors available, making this product able to fit within most interior environments.

APPLICATIONS

- Residential Theaters/Cinemas and Listening Rooms
- Houses of Worship
- Recording Studios and Audio Production Facilities
- Auditoriums, Theaters and Gymnasiums
- Classrooms and Lecture Halls
- Board Rooms and Meeting Facilities
- Offices, Training Centers and Commercial Facilities

Product Overview

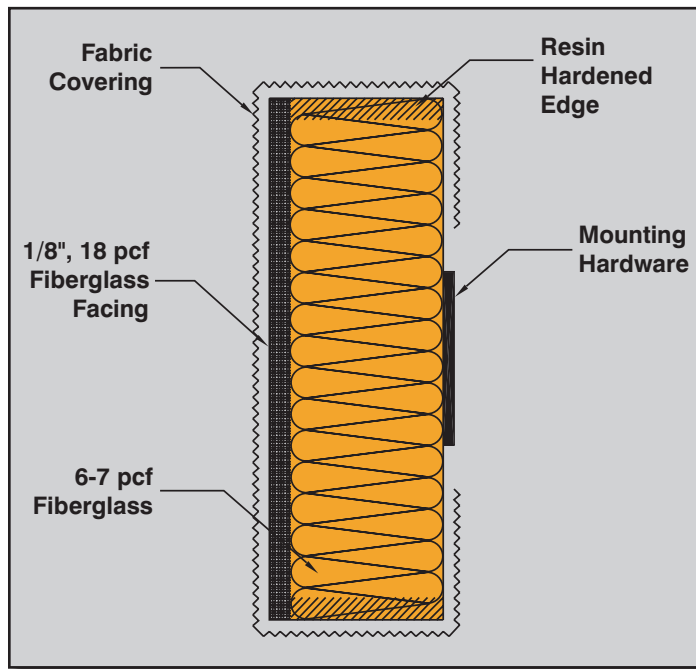

Custom Options

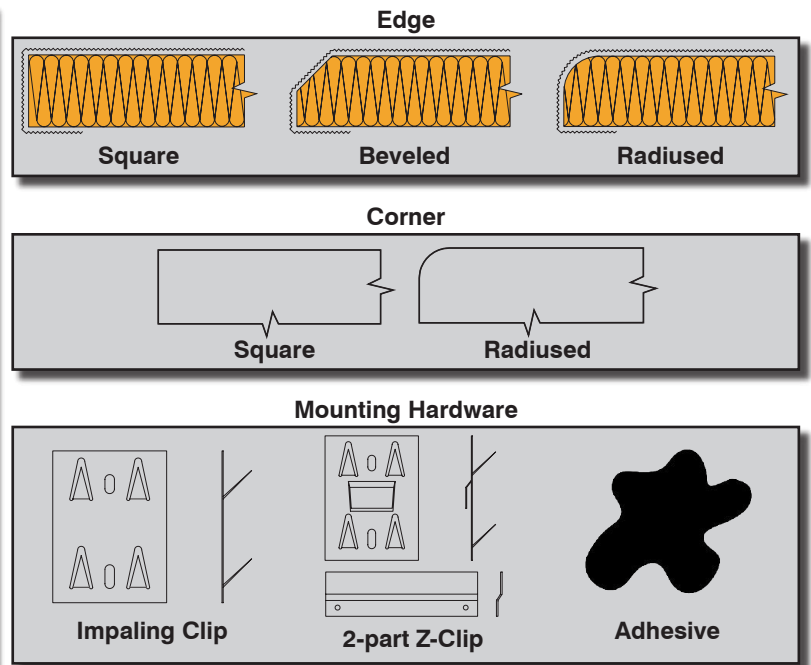

Test Data

	Center Frequency (Hz)						N.R.C.
	125	250	500	1000	2000	4000	
1" IR ProPanel	0.12	0.35	0.90	1.09	1.11	1.08	0.85
2" IR ProPanel	0.51	0.85	1.07	1.01	0.99	1.03	1.00

*All tests independently conducted according to the standards of ASTM C423-90a.

Flammability: Each ProPanel component has a Class A flame rating per ASTM E84

ELITE ProBaffles

PRODUCT DESCRIPTION

ELITE ProBaffles enable a cost-effective aesthetic solution for applications where baffles are needed to improve acoustic performance. ProBaffles can be made of a colored PVC or vinyl wrapping or any one of the hundreds of custom fabrics available. They can be made to hang vertically or horizontally from any ceiling system.

APPLICATIONS

- Offices, Training Centers and Commercial Facilities
- Auditoriums, Theaters and Gymnasiums
- Lecture Halls
- Large Meeting/Presentation Facilities
- Houses of Worship

Product Overview

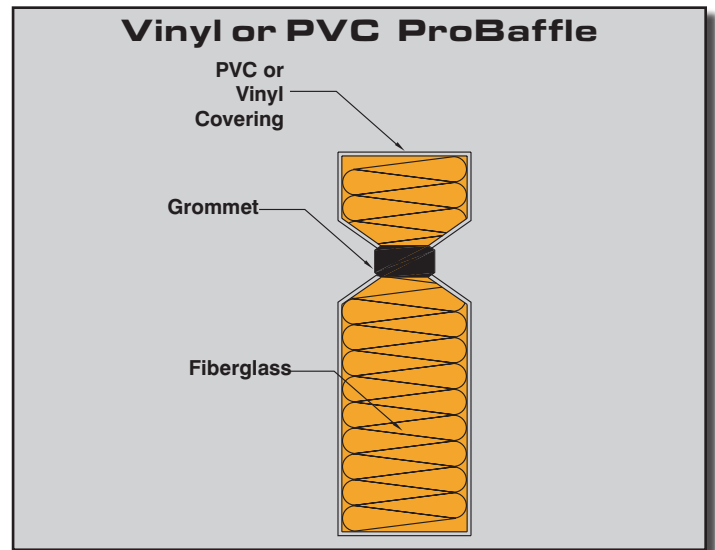
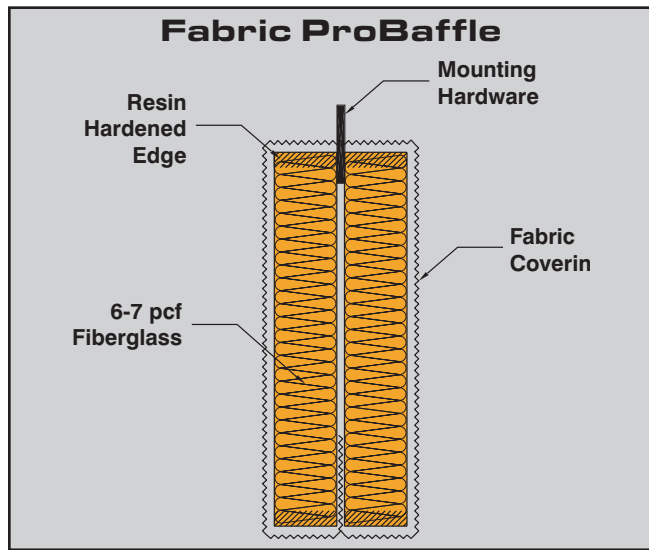

Custom Options

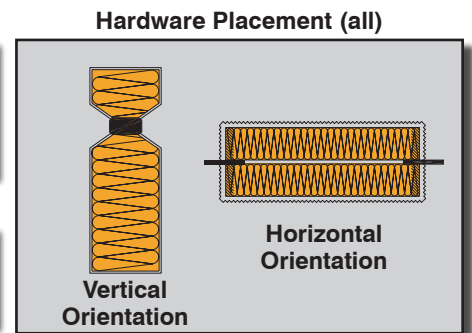
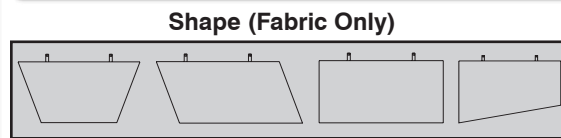
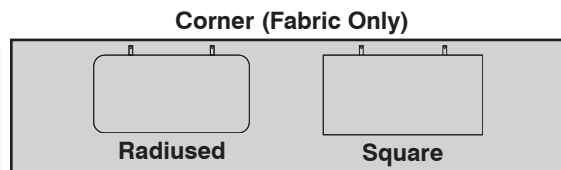
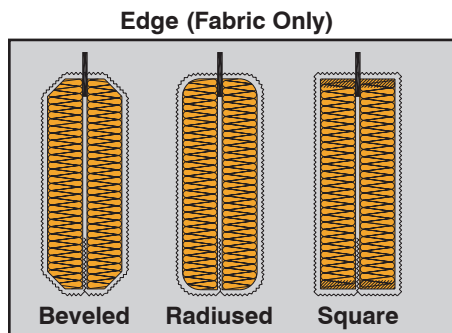

Test Data

	Center Frequency (Hz)						Sabins/sq. ft.
	125	250	500	1000	2000	4000	
2" Fabric Baffle	0.00	0.55	1.73	2.76	2.91	2.86	2.00
2" Vinyl Baffle	0.40	0.74	1.42	1.73	1.60	1.14	1.37

Flammability: Each ProPanel component has a Class A flame rating per ASTM E84

Elegant. Accurate. Brilliant.™