

NOTE:
1. CABLE LENGTH EXTENDS APPROX. 10"
FROM HOUSING.

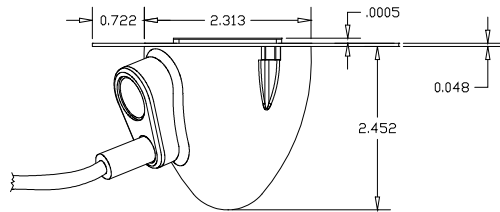
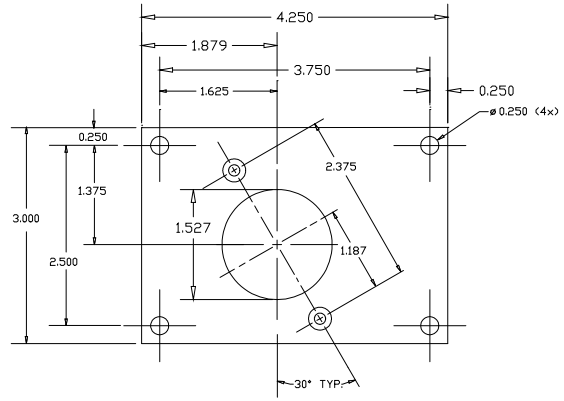
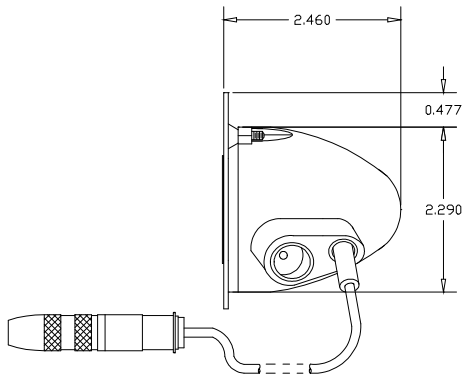

| | | | | |
|-------------|--------------------|----------------------|---------|-------------|
| REV DATE | FIRST MADE FOR 901 | | TITLE | |
| | ASATIC | | WM_1000 | |
| DRAWN | APP'D | 30 NET SCALE DRAWING | SIZE | SCALE |
| LS | [Signature] | 3/4 ANGLE PROJ | C | DWG. NO. |
| RELEASE | 12-06-04 | [Symbol] | SCALE | 124-01-1000 |