



Industrial Audio Products

# CTM 33

## DYNAMIC CARDIOID MICROPHONE

### Description

The **ASTATIC CTM 33** is a dynamic cardioid microphone featuring the sound quality and characteristics demanded by the professional but priced for the budget conscious installer or musician. The **CTM 33** provides the performance and features to satisfy today's most demanding professionals.

The wide and flat frequency response of the **CTM 33** provides unsurpassed natural transparent sound quality. The cardioid pickup pattern minimizes annoying feedback (when used close to sound reinforcement speakers and monitors) and reduces the pickup of unwanted off-axis sounds. An effective internal multistage pop filter minimizes wind and breath noise.

The **CTM 33** has a **Flex-Form™** hardened steel grille screen that dramatically resists deformation while greatly reducing any risk of adverse performance caused by a bent or dented ball screen. This unique ability to retain its original shape assures that the **CTM 33** will maintain its attractive appearance.

The **CTM 33** uses a high energy neodymium magnet.

The low-frequency response of the **CTM 33** may be enhanced by increasing or decreasing the distance from the sound source. This phenomenon is technically known as "proximity effect". Nominal or "flat" response is generated at a distance of 24 inches or more. However, as the distance to the sound source decreases, the bass sensitivity increases, providing a solid, robust character. The **CTM 33** is supplied complete with a zippered vinyl protective pouch and a snap-in microphone swivel-mount.

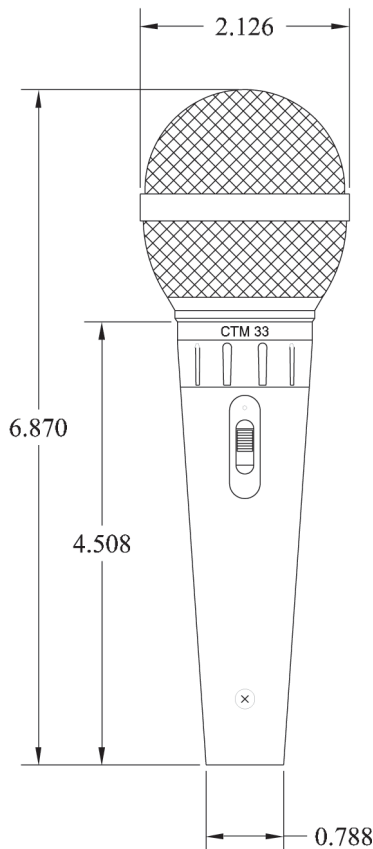

### ASTATIC Quality

All **CTM 33** microphones are audio tested and inspected prior to shipment. Our absolute commitment to quality insures that **ASTATIC** microphones remain the **Best Value** in today's competitive industry.

### Operation and Maintenance

The **CTM 33** is one of the finest values in hand-held vocal microphones available. Although it is incredibly durable it should be stored in the provided zipper pouch to protect it from dust and dirt when not in use.

If the mike housing becomes soiled by dirt or residue it may be cleaned using a cloth dampened with isopropyl alcohol.

# SPECIFICATIONS FOR CTM 33

## Specifications

**Generating Element:**

Moving Coil Dynamic, Neodymium Magnet

**Polar Pattern:**

Unidirectional (Cardioid)

**Frequency Response:**

80 Hz - 12 kHz

**Output Level:**

**Power Level:**

-56 dB (0 dB = 1 mW per 10 microbars)

**Open Circuit Voltage:**

-73 dB (0 dB = 1 volt per microbar)

2.3 mV/Pascal

**Impedance:**

Low (500 ohms nominal)

**Phasing**

Positive Pressure on Diaphragm generates a positive voltage on pin 2 relative to pin 3

**Switch:**

Low profile

**Grille Screen:**

Woven Flex-Form™ (hardened steel)

**Case:**

Die Cast Zinc Alloy

**Finish:**

Durable rubber textured Gunmetal black

**Dimensions:**

(See drawing on other side)

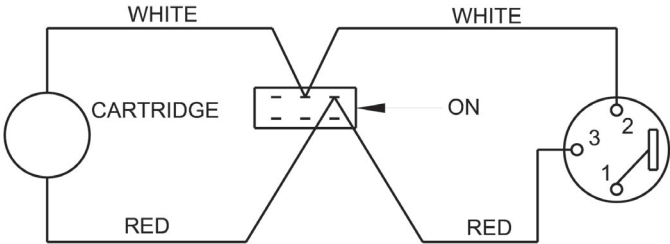
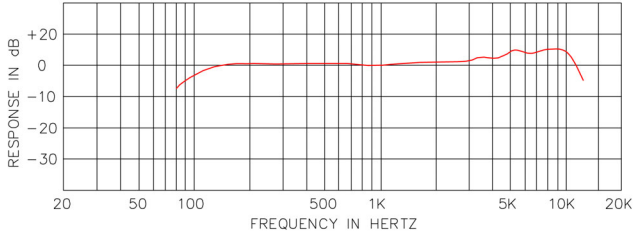
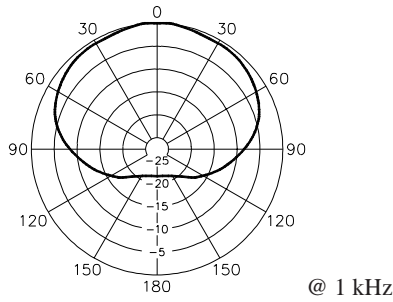

## Architects' and Engineers' Specification

The microphone shall be a dynamic cardioid type, low impedance with wide-range frequency response, uniform from 80 to 12 kHz having an on/off switch. Output level at 1 kHz shall be - 56 dB (0 dB = 1mW/10 microbars). The polar response shall show a minimum of -15 dB at 180 degrees between 200 and 4 kHz. The woven steel screen, when attached to the microphone, shall withstand a drop of 6 feet to a wooden floor without any deformation. The microphone case shall be die-cast zinc alloy. The microphone shall have a length of 6-7/8" ±1/32" and a maximum diameter of 1-1/8" ±1/64". The microphone shall be finished in a rubber textured, non-reflecting black. A snap-in clamp and a zippered vinyl protective pouch shall be supplied.

The **ASTATIC Model CTM 33** is specified.

### TWO-YEAR LIMITED WARRANTY

Omnitronics, LLC ("ASTATIC") hereby warrants that this product will be free of defects in material and workmanship for a period of two years from the date of purchase. In the unlikely event a defect occurs ASTATIC will, at its option, either repair or replace with a new unit of equal or greater value. You should retain proof of purchase to validate the purchase date and return it with any warranty claim. Return warranty claims carefully packed, insured and prepaid to the Service Department at the address listed below.

This warranty excludes exterior finish or appearance, damage from abuse, misuse of the product, use contrary to ASTATIC's instructions or unauthorized repair. All implied warranties or merchantability or fitness for a particular purpose are hereby disclaimed and ASTATIC hereby disclaims liability for incidental, special or consequential damages resulting from the use or unavailability of this product.

This warranty gives you specific legal rights and you may also have other rights which vary from state to state. Some states do not allow the exclusion or limitation of incidental or consequential damages or limitations on how long an implied warranty lasts, so the above exclusions and limitations may not apply to you.

Note: No other warranty, written or oral is authorized by Omnitronics, LLC.