

**Mult
Tasker™**

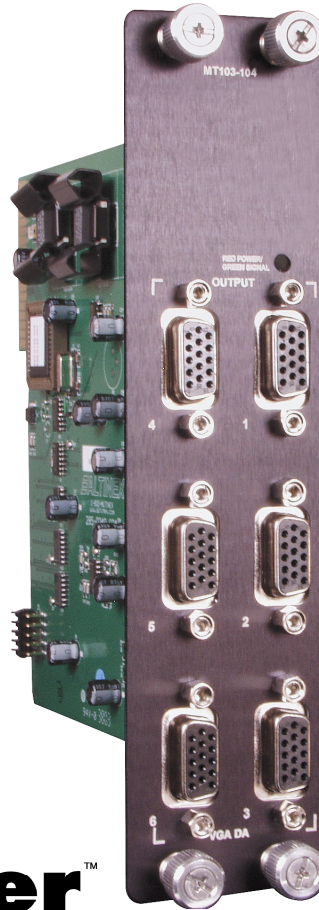

MT103-104 is shown above.

MANUAL PART NUMBER: 400-0090-004

MT103-104/MT103-109/MT103-110

6-OUT VGA DISTRIBUTION AMPLIFIER

EXPANSION CARDS FOR MULTI-TASKER™

ENCLOSURES USER'S GUIDE

TABLE OF CONTENTS

	Page
PRECAUTIONS / SAFETY WARNINGS.....	2
ABOUT YOUR MT VGA DA EXPANSION CARD	3
TECHNICAL SPECIFICATIONS.....	3
PRODUCT DESCRIPTION.....	4
APPLICATION DIAGRAM.....	4
INSTALLING YOUR MT VGA DA EXPANSION CARD	8
OPERATION (FOR MT103-104 ONLY).....	8
7.1 RS-232 CONTROL.....	8
7.2 RS-232 INTERFACE.....	8
7.3 DESCRIPTION OF COMMANDS.....	8
7.4 SUMMARY OF COMMANDS.....	12
TROUBLESHOOTING GUIDE.....	13
ALTINEX POLICY.....	14

PRECAUTIONS / SAFETY WARNINGS 1

Please read this manual carefully before using your **MT103-104/(109)(110)**. Keep this manual handy for future reference. These safety instructions are to ensure the long life of your **MT103-104/(109)(110)** and to prevent fire and shock hazard. Please read them carefully and heed all warnings.

1.1 GENERAL

- Qualified ALTINEX service personnel, or their authorized representatives must perform all service.

1.2 INSTALLATION

- To prevent fire or shock, do not expose this unit to rain or moisture. Do not place the **MT103-104/(109)(110)** in direct sunlight, near heaters or heat radiating appliances, or near any liquid. Exposure to direct sunlight, smoke, or steam can harm internal components.
- Handle the **MT103-104/(109)(110)** carefully. Dropping or jarring can damage the card.
- Do not pull the cables that are attached to the **MT103-104/(109)(110)**.
- Insert the card carefully into the slots of the Multi-Tasker™ without bending any edges.
- When removing a card, please make sure that the card to which it is attached is also pulled out simultaneously.

1.3 CLEANING

- Clean only the connector area with a dry cloth. Never use strong detergents or solvents, such as alcohol or thinner. Do not use a wet cloth or water to clean the card. Do not clean or touch any component or PCB.

1.4 FCC / CE NOTICE

- This device complies with part 15 of the FCC Rules. Operation is subject to the following two conditions: (1) This device may not cause harmful interference, and (2) this device must accept any interference received, including

interference that may cause undesired operation.

- This equipment has been tested and found to comply with the limits for a Class A digital device, pursuant to Part 15 of the FCC Rules. These limits are designed to provide reasonable protection against harmful interference when the equipment is operated in a commercial environment. This equipment generates, uses, and can radiate radio frequency energy and, if not installed and used in accordance with the instruction manual, may cause harmful interference to radio communications. Operation of this equipment in a residential area is likely to cause harmful interference in which case the user will be required to correct the interference at his own expense.
- Any changes or modifications to the unit not expressly approved by ALTINEX, Inc. could void the user's authority to operate the equipment.

ABOUT YOUR MT VGA DA EXPANSION CARD 2

MT103-104, MT103-109 & MT103-110 6-out VGA Distribution Amplifier Expansion Cards

The **MT103-104**, **MT103-109** and **MT103-110** are 6-out VGA Distribution Amplifier Expansion Cards are designed to connect via a short internal cable to either the MT103-102 or MT103-103 in a MultiTasker™ enclosure. When installed along with a MT VGA DA Card in a MultiTasker™ enclosure, these MT VGA DA Expansion cards consume 2 slots and expand the number of outputs by 6.

For example, the **MT103-104** used together with the MT103-102 provides a total of 9 VGA-type outputs. The **MT103-104** used together with the MT103-103 provides a total of 12 VGA-type outputs. The **MT103-104** can also pass RGBHV type signals if the outputs are adapted from 15-pin HD connectors to 5 BNC connectors using ALTINEX adapter cables.

For high performance applications, the **MT103-104** and **MT103-110** have industry leading 350MHz bandwidth. Additionally, the **MT103-104** provides “on-off control” of each output, augmented by Screen Blanking, which eliminates annoying signal loss messages by maintaining the Sync signal on all attached projectors and monitors.

For the most economical configurations, the **MT103-109** offers a low cost expansion solution for “always on” distribution, and solid 250 MHz bandwidth performance.

TECHNICAL SPECIFICATIONS 3

FEATURES/DESCRIPTION	MT103-104/(109)(110)
GENERAL	
Inputs	
Input Connector	(1) Internal 10-pin IDC + (1) cable (included)
Outputs	
Output Connectors	6 15-pin HD Female
Compatibility (* requires the use of adapters, see Optional Accessories)	RGBS*, RGBHV* VGA through QXGA (MT103-104/110 only) VGA through UXGA

	(MT103-109 only)
Approvals	CE, FCC

Table 1. MT103-104/(109)(110) General

MECHANICAL	MT103-104/(109)(110)
Enclosure Slots Required	Two
Weight	0.6 lb. (0.27kg)
Shipping Weight	1.1 lb. (0.5kg)
Connector Panel	Black
T° Operating	10°C to 40°C
T° Storage	0°C to 50°C
Humidity	90% non-condensing
MTBF (calc.)	40,000 hrs

Table 2. MT103-104/(109)(110) Mechanical

ELECTRICAL	MT103-104/(109)(110)		
Output Video Signal			
Analog	-3V to +1.5V (1.5V p-p max.)		
Impedance	75 Ohms		
Gain	1.05		
Crosstalk	-39dB @ 15MHz		
DC Offset	+/-20V max, input = 0V		
Output Sync Signal			
Horizontal, Vertical	TTL (+/-)		
Impedance	22 Ohms		
Propagation Delay	6nS max.		
Rise/Fall Time	45nS max.		
DC Offset	+/- .1V max, input = 0V		
Frequency Compatibility			
Horizontal	15-200 kHz		
Vertical	20-180 Hz		
Bandwidth			
MT103-104, MT103-110	350 MHz @ -3dB		
MT103-109	250 MHz @ -3dB		
Power	+6V	-6V	Power Consumption
MT103-104	250 mA	220 mA	2.8 watts
MT103-109	270 mA	120 mA	2.4 watts
MT103-110	315 mA	265 mA	3.5 watts
Optional Accessories			
MS8102CA	6ft, 15-pin HD-M to 5-BNC M		
MS8106CA	6ft, 15-pin HD-M to 5-BNC F		

Table 3. MT103-104/(109)(110) Electrical

PRODUCT DESCRIPTION 4

APPLICATION DIAGRAM 5

Application 1

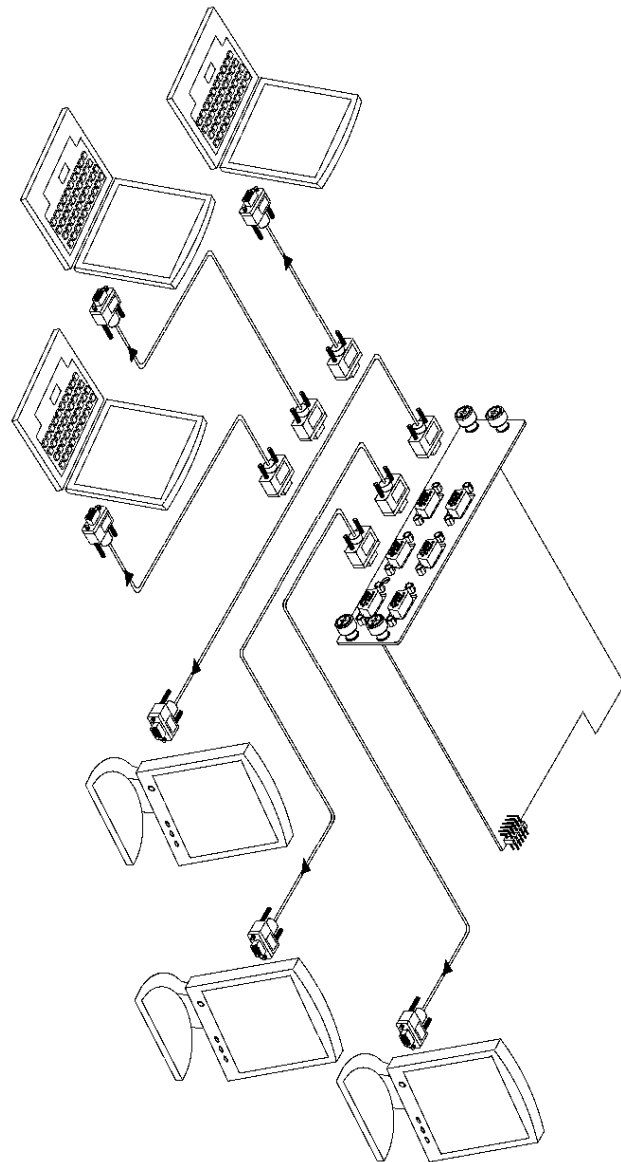
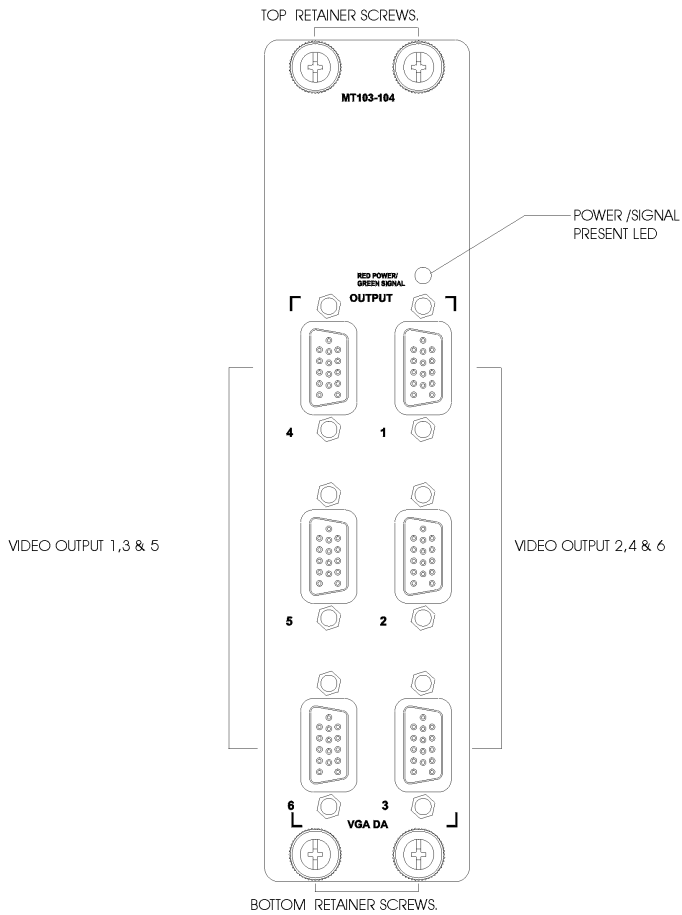

Application 2: Internal View of the MT VGA DA Expansion Cards

MT103-104

6 VGA EXPANSION CARD + 350MHZ + SIGNAL DET+ ON/OFF + SYNC BEHIND

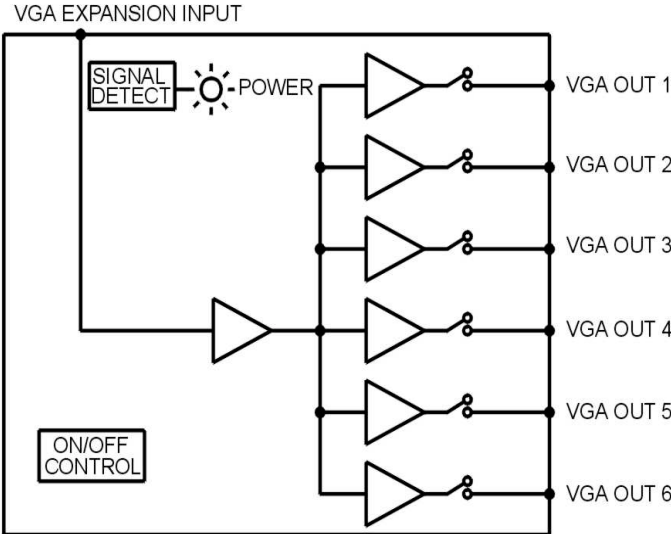

MT103-109

6 OUT EXPANSION CARD VGA + 250MHZ + SIG. DETECT

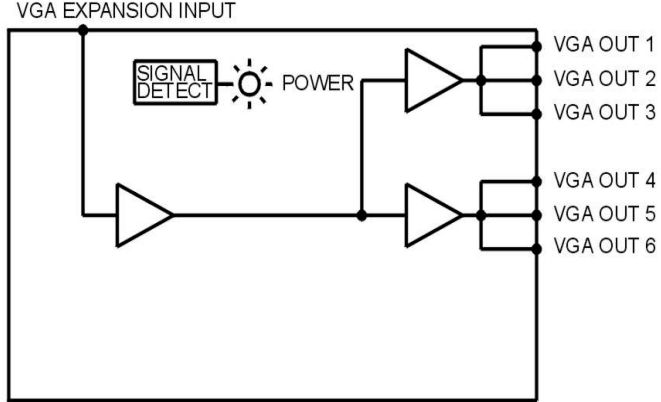

MT103-110

6 OUT VGA EXPANSION CARD + 350MHZ + SIGNAL DET

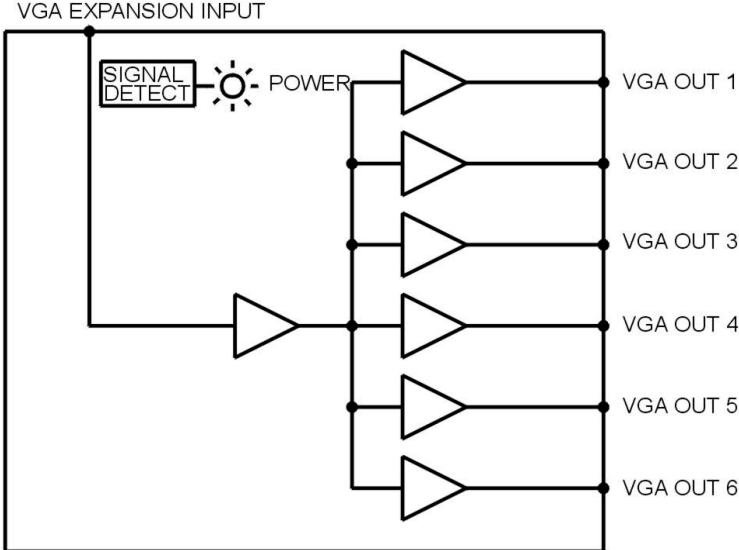

Application 3: RGBHV Switching

Use the **MT103-104/(109)(110)** card for RGBHV signals to display more than 6 monitors. You need one **MT103-104/(109)(110)** Expansion card and one **MT103-102/(103)** MT VGA DA card.

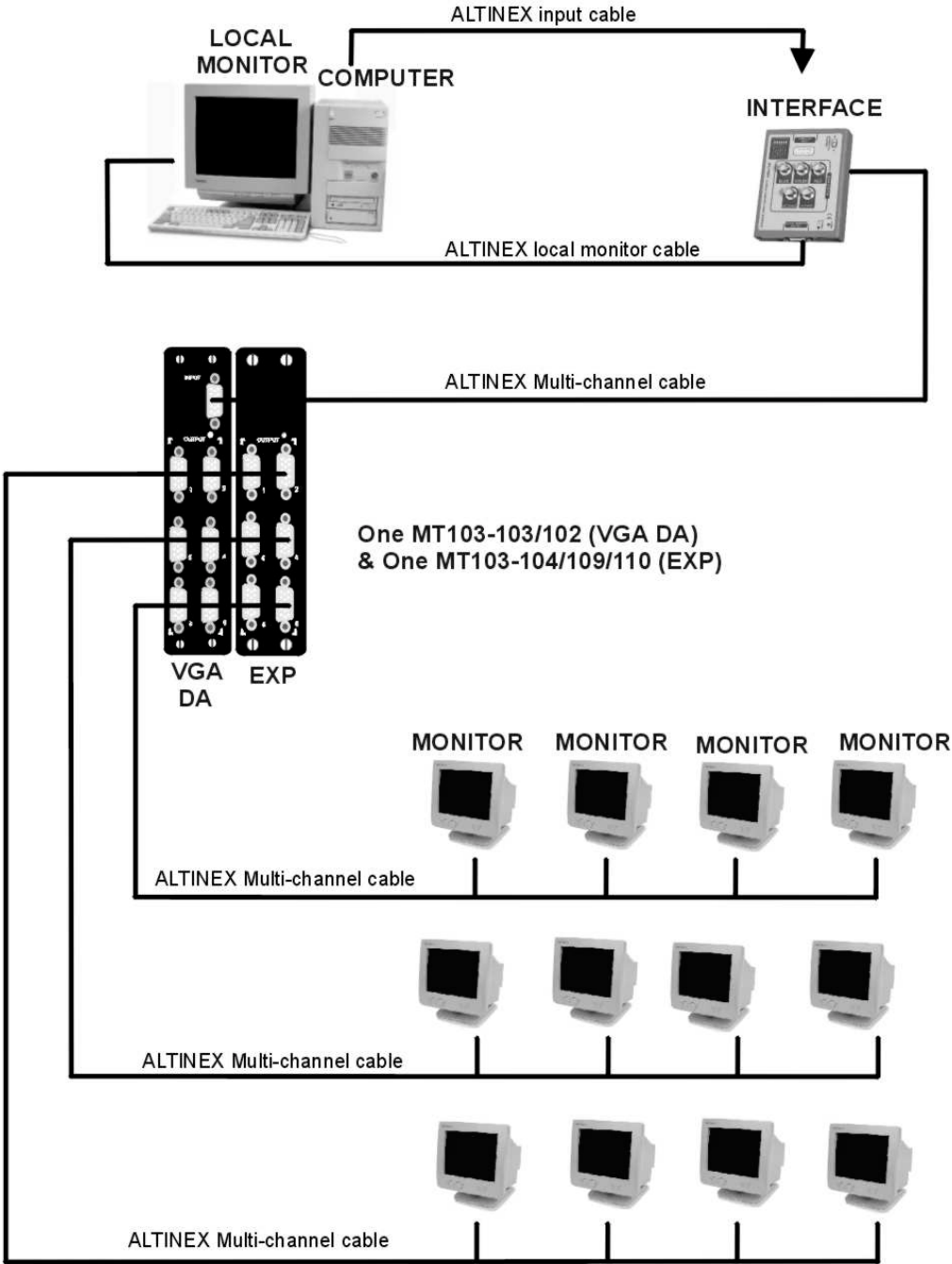

Application 4:
Connection of MT103-102/103 to MT103-104/109/110

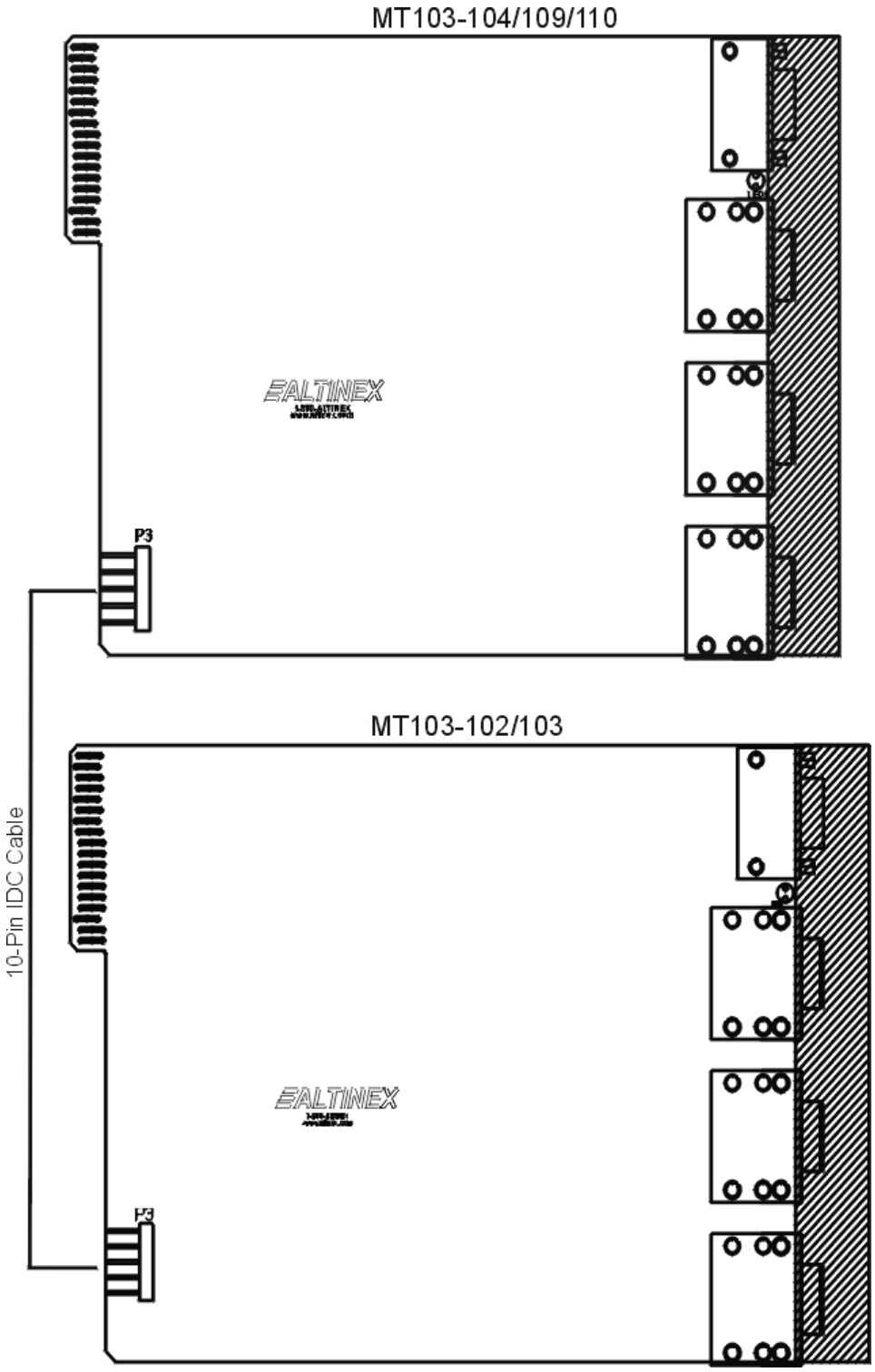

INSTALLING YOUR MT VGA DA EXPANSION CARD 6

- Step 1.** Connect the 10-pin IDC cable from the MT VGA DA Card (MT103-103/102) to the control port, P3 of the **MT103-104/(109)(110)** (see Application 4). Note this connection will provide RGBHV to the **MT103-104/(109)(110)**.
- Step 2.** Slide the (previously connected) MT VGA DA Card (MT103-103/102) and the **MT103-104/(109)(110)** into available slots in the Multi-Tasker™ Enclosure. The VGA DA (MT103-103/102) will connect to the bus. Make sure that the **MT103-104/(109)(110)** and the VGA DA Card (MT103-103) fit into place. Secure the cards to the Multi-Tasker™ by tightening the retainer screws located on the top and bottom of each card. The **MT103-104/(109)(110)** should be mounted to the right of the (MT103-103) VGA DA Card.
- Step 3.** Connect a VGA cable from the video source to the input connector of the VGA DA Card (MT103-103/102). Connect the output of the **MT103-104/(109)(110)** to the display devices through a VGA cable.
- Step 4.** Starting from the left, identify the slot number where the **MT103-104/(109)(110)** card is plugged into the Enclosure and note that it is for RS-232 control.

OPERATION (for MT103-104 only) 7

7.1 RS-232 CONTROL

The outputs of the **MT103-109** and the **MT103-110** are always enabled; therefore, no RS-232 control is necessary.

When used in the Multi-Tasker™ Enclosure, the **MT103-104** has many advanced remote control capabilities, which are accessible through standard RS-232 communication. The actual controlling can be accomplished through a

computer control system or any other device capable of sending RS-232 commands.

7.2 RS-232 INTERFACE

The RS-232 commands for the **MT103-104** are in a simple ASCII character format.

1. Square brackets “[]” are part of the command.
2. Use uppercase letters for all commands.

After processing a command, an OK or ER string will be returned as feedback if "F" is included at the end of a command string or if the unit ID is zero.

Commands such as [ON], [OFF], and [IO] that end in "S" will be saved into memory. Commands not ending in "S" will still be executed but will not be restored when the system is reset (power off & power on again).

7.3 DESCRIPTION OF COMMANDS

Each command consists of three parts: function, card ID, and unit ID. [Function, Card ID, Unit ID]

Example:

[VERC3U2]

VER = function

C3 = Card ID

U2 = Unit ID

For function, see a detailed explanation under each command description.

Card ID is an assigned value from 1 to 19 (1 to 8 or 1 to 4 depending on which enclosure is being used), which represents the number of slots. Card ID 0 (C0) is used for the controller (see user's guide for the MT100-100). Changing the position of a card will significantly affect the commands recorded on software definitions or a third party control system.

Unit ID has a value from 0 to 9. Unit ID 0 should be used for single unit operation. If the Unit ID is set to 0, then each command can be used

without Ui (use command **[SETU0]**; see user's guide for the MT100-100).

Example:

[VERC3]: for unit ID zero

[VERC3Ui]: for unit ID other than zero

[VERC3]: equivalent to [VERC3U0]

1. [VER]

This command displays the software version and card type for the **MT103-104** card.

Command Format: [VERCnUi]

Cn = card ID No. (n = slot # from 1 to 19)

(1-8 for MT100-101 or 1-4 for MT100-106)

Ui = Unit ID (i = # from 0 to 9) (*refer to the MT100-100 user's guide for explanation*)

Example:

If one **MT103-104** card is in slot #2 of unit 3:

To send command **[VERC2U3]**, the Multi-Tasker™ Enclosure will return:

MT103-104 690-0125-009

690-0125-009 = software version

MT103-104 = card number

2. [C]

This command receives the status of the card.

Command Format: **[CnUi]**

Cn = card id (n = slot # from 1 to 19)

(1-8 for MT100-101 or 1-4 for MT100-106)

Ui = unit id (i = from 0 to 9) (*refer to the MT100-100 user's guide for explanation*)

Example:

If one **MT103-103** card is in slot #2 of unit 3 with output 1 and 2 ON, to send command **[C2U3]**, the Multi-Tasker™ Enclosure will return feedback as:

ON:1,2 C02

ON:1,2 = outputs 1 and 2 enabled

C02 = card 2

If there is no card in slot #2 of unit 3, there will be no feedback.

3. [CiS]

This command saves the current status of the card's input to output configuration. This configuration will be restored after system is reset or powered off then on.

Ci = card number

S = save configuration

If Inputs 1,2,3,4,5 and 6 are enabled, the feedback after sending the command **[C4S]**, for slot 4, would be:

ON:1,2,3,4,5,6 C04 Saved

4. [SIGCi]

The Signal Present command tests for the presence of an input signal on the input. After sending the command, the feedback will be either "1" signifying a signal is present, or "0" indicating no signal was detected.

i = Slot Number

Example:

To check for the presence of an input signal on card 4, send the command **[SIGC4]** and verify feedback of "1" or "0".

5. [ON]

This command enables one or more outputs of a single card or group of cards.

[ONmCnUiS]: for a single card

This command enables output "m" without affecting any other outputs.

Default when plugged in = ALL OFF

m = Output number (m = 1 to 6)

Cn = Card ID number (n = 1 to 19)

(1-8 for MT100-101 or 1-4 for MT100-106)

Ui = Unit ID number (i = 0 to 9)

S = saves command to memory

Example:

- 1) **[ON12C5U3]:** Turns ON only outputs 1 and 2 of the **MT103-104** card located in slot #5 of the MT100-100 Enclosure with unit ID3.
- 2) **[ON3C5U3]:** Turns ON only output 3 of the **MT103-104** card located in slot #5 of the MT100-100 Enclosure with unit ID3. After the **[ON12C5U3]** and **[ON3C5U3]** commands have been executed, outputs 1, 2 and 3 will be ON.
- 3) **[ONC5U3]:** Turns ON all outputs of the card.

[ONmGkUiS]: for a group of cards

This command enables output "m" for each card in group "k" of unit "i".

m = card output (m = # from 1-6)

Gk = group number (k = # from 1-9)

Ui = unit number (i = # from 0-9)

S = saves command to memory

Example:

1. **[ON1G5U1]:** Turns ON output 1 for each card in group 5 of unit 1.
2. **[ONG5U1]:** Turns ON all outputs for each card in group 5 of unit 1.

[ON.....P]: sets path

This command will set the path for the output, but it is not active until the switch command is executed ([SW]). Commands ending in "P" are not executed immediately. The path for outputs on multiple cards or the same card can be loaded.

Command Format: **[ONmCnUiP]**

m = output number (m =1 to 6)

Cn = card ID No. (n = a slot # from 1 to 19)
(1-8 for MT100-101 or 1-4 for MT100-106)

Ui= Unit ID number (i = 0 to 9)

P = path

Example:

If 2 cards are in slot 6 and 7 of unit 3:

To enable output 1 of card 6 and output 3 of card 7 simultaneously, use the following commands:

[ON1C6U3P]

[ON3C7U3P]

[SW]

If "F" is included use the **[ONmCnUiPF]** command or the **[ONmCnUiFP]** command.

[ON.....F]: feedback

After processing a command, an OK or ER will be returned as feedback if "F" is included at the end of a command string or if the unit ID is zero.

Example:

[ON1C2U3F]: if path is not set

[ON1C2U3PF]: if path is set

6. [OFF]

This command disables one or more outputs of a single card or a group of cards.

[OFFmCnUiS]: for a single card

This command disables output "m" without affecting any other outputs.

m = output number (m = 1 to 6)

Cn = card ID No. (n = slot # from 1 to 19)
(1-8 for MT100-101 or 1-4 for MT100-106)

Ui = Unit ID number (i = 0 to 9)

S = saves command to memory

[OFFCnUi]: Turns OFF all outputs of the card

Example:

- 1) If card 5 of unit 3 has output 1, 2 and 3 ON:
 - a) **[OFF1C5U3]:** Turns OFF output 1 while output 2 and 3 remain ON.
 - b) **[OFF23C5]:** Turns OFF output 2 and 3.
 - c) **[OFFC5U3]:** Turns OFF all outputs, which is equivalent to **[OFF123456C5U3]**.

[OFFmGkUiS]: for a group of cards

This command disables output "m" for each card in group "k" of unit "i".

m = card output (m = # from 1-6)

Gk = group number (k = # from 1-9)

Ui = unit number (i = # from 0-9)

S = saves command to memory

Example:

1. [OFF1G5U1]: Turns OFF output 1 for each card in group 5 of unit 1.
2. [OFFG5U1]: Turns OFF all outputs for each card in group 5 of unit 1.

[OFF.....P]: sets path

This command will set the path for the output, but it is not active until the switch command is executed ([SW]). Commands ending in "P" are not executed immediately. The path for outputs on multiple cards or the same card can be loaded.

Command Format: [OFFmCnUiP]

m = number (m =1 to 6)

Cn = card ID No. (n = a slot # from 1 to 19)
(1-8 for MT100-101 or 1-4 for MT100-106)

Ui = unit number (i = # from 0-9)

P = path

Example:

If 2 cards are in slot 6 and 7 of unit 3, to enable outputs 1 and 2 of card 6 and outputs 3 and 4 of card 7, simultaneously use the following commands:

```
[OFF12C6U3P]
```

```
[OFF34C7U3P]
```

```
[SW]
```

If "F" is included use the [OFFmCnUiPF] command or the [OFFmCnUiFP] command.

[OFF.....F]: feedback

After processing a command, an OK or ER will be returned as feedback if "F" is included at the

end of a command string or if the unit ID is zero.

Example:

[OFF1C2U3F]: if path is not set

[OFF1C2U3PF]: if path is set

7. [...S] – Save

This command will save the configuration command being sent in memory. When sending the command [ON1C4S], after reset or power up, output 1 on C4 will be enabled.

8. [...P] – Path

This command will set the path for the output, but it is not active until the switch command, [SW], is executed. Commands ending in "P" are not executed immediately. The path for outputs on multiple cards or the same card can be loaded. See examples in ON and OFF commands.

9. [...F] – Feedback

After processing a command, an OK or ER will be returned as feedback if "F" is included at the end of a command string or if the unit ID is zero.

10. [SW] – Switch

The switch command immediately connects inputs and outputs, which were previously set with the path command on this card and all other cards in the MT100-100.

The system will return feedback as **OK**.

11. [WR]

This command groups multiple cards in the MT100-100 Enclosure. Each unit contains a maximum of nine groups.

Command Format: [WRCn...GkUi]

Cn = card ID No. (n = slot # from 1 to 19)
(1-8 for MT100-101 or 1-4 for MT100-106)

Gk = group number (k = # from 1-9)

Ui = unit number (i = # from 0-9)

Example:

To group cards #1, 2, and 3 as group 5 of unit #1, send the command [WRC1C2C3G5U1]. After executing this command, cards 1, 2, and 3 of unit 1 will be grouped as group 5.

12. [CLR]

This command clears the members for a single group or for all nine groups.

Command Format: [CLRgkUi]

Gk = group number (k = # from 1-9)

Ui = unit number (i = # from 0-9)

Example:

- a) To clear group #1, send the [CLRg1U1] command. This command clears the members for the specified group only.
- b) To clear all groups of unit 1, send the [CLR G[U1] command.

13. [G]

This command is used to request group data. With the command, the user can identify which input or output of a particular group is on.

Command Format: [GkUi]

Gk = group number (k = # from 1-9)

Ui = unit number (i = # from 0-9)

Example:

If group 1 has DA Cards with output 1 and 2 on, while group 2 has SW Cards with input 2 on:

- 1) **[G1]:** will return feedback as **[On12G1]**.
- 2) **[G2]:** will return feedback as **[On2G2]**.

14. [RD]

This command displays the members in each group.

Command Format: [RDgkUi]

Gk = group number (k = # from 1-9)

Ui = unit number (i = # from 0-9)

members = C1 - C19 (card 1 to 19)

(1-8 for MT100-101 or 1-4 for MT100-106)

Example:

To read member data for group 1 of unit 1, send the [RD] command. The system will return feedback as C1C2C3 G5U1.

15. [HELP]

This command displays all information available for user Multi-Tasker interface commands.

7.3 SUMMARY OF COMMANDS

- 1) **[VER]** Receives software version
- 2) **[Ci]** Receives status of the card
- 3) **[CiS]** Saves card configuration
- 4) **[SIGCi]** Check for input signal presence
- 5) **[ON]** Turns on one or more outputs for a single card or a group of cards
- 6) **[OFF]** Turns off one or more outputs for a single card or a group of cards
- 7) **[...S]** Save the command configuration sent
- 8) **[...P]** Sets the path, preload for [SW]
- 9) **[...F]** Provides feedback upon sending
- 10) **[SW]** Switch (outputs the preloaded buffer)
- 11) **[WR]** Groups multiple cards
- 12) **[CLR]** Reset card configuration or clears members of a single group or all groups
- 13) **[G]** Requests group data
- 14) **[RD]** Displays the members in each group
- 15) **[HELP]** Display all available commands

TROUBLESHOOTING GUIDE 8

We have carefully tested and have found no problems in the supplied **MT103-104/(109)(110)**; however, we would like to offer suggestions for the following:

8.1 LED IS NOT LIT

Cause 1: The CPU on the card is not working properly.

Solution 1: Look at the card and verify that there is no damage. If there is no damage, see Solution 2.

Solution 2: Verify that all IC's are seated in their sockets. If there is still an

Solution 3: Call ALTINEX at (714) 990-2300.

Cause 2: The MT103-104/(109)(110) card and its serial device are not communicating.

Solution 1: Turn the system OFF and then ON again. If there is still an error, see Solution 3.

Solution 2: Call ALTINEX at (714) 990-2300.

Cause 3: RS485 communication error

Solution 1: Make sure that the card is pushed all the way into the slot.

Solution 2: Turn the system OFF and then ON again. If there is still an error, see Solution 3.

Solution 3: If there is still a problem, call ALTINEX at (714) 990-2300.

Cause 4: Card cage slot has a problem.

Solution 1: Test the card in other slots of the card cage. If the slot was damaged, the card may work in other slots. If other slots work and the LED lights, the problem is the card cage slot. The card cage may require service. Call ALTINEX at (714) 990-2300. If the other slots do not work and the LED is still not lit, see Solution 2.

Solution 2: Take any other known good card with an LED and verify that the slot used is good by seeing if the other card's LED lights in that slot. If it lights, then the original card may be the source of the problem. Call ALTINEX at (714) 990-2300.

8.2 LED ON CARD IS BLINKING RED

Cause 1: The CPU on the card is not working properly.

Solution 1: Look at the card and verify that there is no damage. If there is no damage, see Solution 2.

Solution 2: Verify that all IC's are seated in their sockets. If the LED is still blinking red, see Solution 3.

Solution 3: Call ALTINEX at (714) 990-2300.

Cause 2: The MT103-104/(109)(110) card and its serial device are not communicating.

Solution 1: Turn the system OFF and then ON again. If there is still an error, see Solution 3.

Solution 2: Call ALTINEX at (714) 990-2300.

Cause 3: RS485 communication error

Solution 1: Make sure that the card is pushed all the way into the slot. If there is still an error, see Solution 2.

Solution 2: Turn the system OFF and then ON again. If there is still an error message, see Solution 3.

Solution 3: If there is still a problem, call ALTINEX at (714) 990-2300.

8.3 NO DISPLAY

Cause 1: The source has a problem.

Solution: Check the source and make sure that there is a signal present and all source connections are correct. If the source is working and there is still no display, see Cause 2.

Cause 2: The card output is turned OFF.

Solution 1: Turn ON the card output that is used. See RS-232 accessible commands in section 7. If no display is present, see Cause 3.

Cause 3: Cable connections to the destination are incorrect.

Solution: Make sure that cables are connected properly. Also, make sure that the continuity and wiring are good. If there is still no display present, see Cause 4.

Cause 4: The display has a problem.

Solution 1: Make sure that the display is powered. If there is still no display, call ALTINEX at (714) 990-2300.

ALTINEX POLICY

9

9.1 LIMITED WARRANTY / RETURN POLICY

Please see the Altinex website at www.altinex.com for details on warranty and return policy.

9.2 CONTACT INFORMATION

ALTINEX, INC

592 Apollo street

Brea, CA 92821 USA

TEL: 714 990-2300

TOLL FREE: 1-800-ALTINEX

WEB: www.altinex.com

E-MAIL: solutions@altinex.com