

MANUAL PART NUMBER: 400-0091-003

TNP500

Universal Tilt 'N Plug™ Interconnect Box

USER'S GUIDE

INTRODUCTION

Your purchase of the **TNP100 Tilt ‘N Plug™** Interconnect Box is greatly appreciated. We are sure you will find it reliable and simple to use.

Superior performance for the right price, backed by solid technical and customer support is what ALTINEX has to offer.

The product you are holding in your hands is designed using state-of-the-art technology and is superior to anything available on the market. You will find this and our other products reliable, long lasting, and simple to operate.

We are committed to providing our customers with signal management solutions to the most demanding audio-visual installations at very competitive pricing.

We appreciate your selection of our products and are confident that you will join the ranks of our many satisfied customers throughout the world.

This manual covers:

TNP100 – Tilt ‘N Plug™ Interconnect Box.

TABLE OF CONTENTS

	Page
PRECAUTIONS / SAFETY WARNINGS.....	2
GENERAL	2
INSTALLATION	2
CLEANING	2
FCC / CE NOTICE.....	2
ABOUT YOUR TNP500	3
TECHNICAL SPECIFICATIONS	3
TNP500 DIMENSIONS	4
DIAGRAMS 1A-1D.....	4
DESCRIPTION DIAGRAM.....	5
DIAGRAM 2.....	5
APPLICATION DIAGRAM.....	5
DIAGRAM 3.....	6
DIAGRAM 4.....	7
DIAGRAM 5.....	8
INSTALLATION	7
OPERATION.....	8
FREQUENTLY ASKED QUESTIONS (FAQ)	10
CABLES AND ACCESSORIES.....	11
TROUBLESHOOTING GUIDE.....	11
ALTINEX POLICY.....	12
LIMITED WARRANTY	12
RETURN POLICY.....	12
CONTACT INFORMATION	12

PRECAUTIONS / SAFETY WARNINGS 1

Please read this manual carefully before using your **TNP500** Interconnect Box. Keep this manual handy for future reference. These safety instructions are to ensure the long life of your **TNP500** and to prevent fire and shock hazard. Please read them carefully and heed all warnings.

1.1 GENERAL

- Unauthorized personnel shall not open the unit since there are high-voltage components inside.
- Qualified ALTINEX service personnel, or their authorized representatives must perform all service.



1.2 INSTALLATION

- For best results, place the **TNP500** Interconnect Box in a dry area away from dust and moisture.
- To prevent fire or shock, do not expose this unit to rain or moisture. Do not place the **TNP500** Interconnect Box in direct sunlight, near heaters or heat radiating appliances, or near any liquid. Exposure to direct sunlight, smoke, or steam can harm internal components.
- Handle the **TNP500** Interconnect Box carefully. Dropping or jarring can damage internal components.
- Never place fingers inside the opening on each side of the unit. This action could cause serious injury because of the sharp edges inside of the **TNP500**.

- Do not place heavy objects on top of the **TNP500**. Do not use excessive force to push down on the top of the unit.
- To turn off the main power, disconnect the power cord, which powers the power socket on the **TNP500** pop up panel. The power outlet socket should be installed as near to the equipment as possible, and should be easily accessible.
- We recommend using wall outlets with a Ground Fault Circuit Interrupter (GFCI) for maximum protection.
- Install all cables according to the instructions. Do not force or pull out any cable or power cord that is attached to the **TNP500** Interconnect Box.

1.3 CLEANING

- Surfaces should be cleaned with a dry cloth. Never use strong detergents or solvents, such as alcohol or thinner. Do not use a wet cloth or water to clean the unit.

1.4 FCC / CE NOTICE

- This device complies with part 15 of the FCC Rules. Operation is subject to the following two conditions: (1) This device may not cause harmful interference, and (2) this device must accept any interference received, including interference that may cause undesired operation.
- This equipment has been tested and found to comply with the limits for a Class A digital device, pursuant to Part 15 of the FCC Rules. These limits are designed to provide reasonable protection against harmful interference when the equipment is operated in a commercial environment. This equipment generates, uses, and can radiate radio frequency energy and, if not installed and used in accordance with the instruction manual, may cause harmful interference to radio communications. Operation of this equipment in a residential area is likely to cause harmful interference in which case

the user will be required to correct the interference at his own expense.

- Any changes or modifications to the unit not expressly approved by ALTINEX, Inc. could void the user's authority to operate the equipment.

ABOUT YOUR TNP500 2

The **TNP500** is designed for installation into a conference room table. The **TNP500 Tilt 'N Plug™** Interconnect Box provides a means of connecting audio, video, control, and computer video sources into a presentation system. It is ideal for use together with ALTINEX computer video interfaces. The **TNP500 Tilt 'N Plug™** Interconnect Box can either pop up and "tilt" to a raised position to provide access to the connectors or it can be lowered into a table when not in use. A pneumatic spring inside the **TNP500's** tower type construction applies pressure to the panel mechanism, making it easy to raise and secure the unit firmly in an open position.

The **TNP500 Tilt 'N Plug™** Interconnect Box is designed with open architecture in mind. Different sanp in plates can be installed to make custom configuration of the **TNP500** simple. For additional information regarding optional connectors, contact the ALTINEX Sales Department.

The **TNP500 Tilt 'N Plug™** Interconnect Box is designed for use with tables ranging from one to three inches thick. The **TNP500 Tilt 'N Plug™** comes in a standard matte black color; however, it can be finished to match the table. This is available on a custom per order basis at an additional charge.

TECHNICAL SPECIFICATIONS 3

FEATURES/DESCRIPTION	TNP500	
GENERAL		
Front Panel Standard Configuration Connectors	Faceplate	Available location
Power	2 outlet per plate	Up to 3 plates
Computer Video	1 15-pin HD-F	Up to 6 plates
Composite Video	1 Yellow RCA-F	Up to 6 plates
Audio, left, right	1 Black, 1 Red RCA-F	Up to 6 plates
Audio	1 3.5 mm stereo female plug	Up to 6 plates
Telephone	1 RJ-11 F (6-position)	Up to 6 plates
Network	1 RJ-45-F (8-position)	Up to 6 plates
Control	1 DB-9 F	Up to 6 plates

Table 1. **TNP500** General

MECHANICAL	TNP500
Width (inches)	6.03in (153mm)
Height (closed)	4.79in (122mm)
Height (opened)	8.05in (205mm)
Depth (inches)	7.56in (192mm)
Finish	Flat Black
T° Operating	10°C-45°C
T° Maximum	60°C
Humidity	90% non-condensing

Table 2. **TNP500** Mechanical

ELECTRICAL	TNP500
Power	
Power Rating (pass through connector)	90-140 VAC, 5Amps Max

Table 3. **TNP500** Electrical

TNP500 DIMENSIONS 4

Different Views of the TNP500

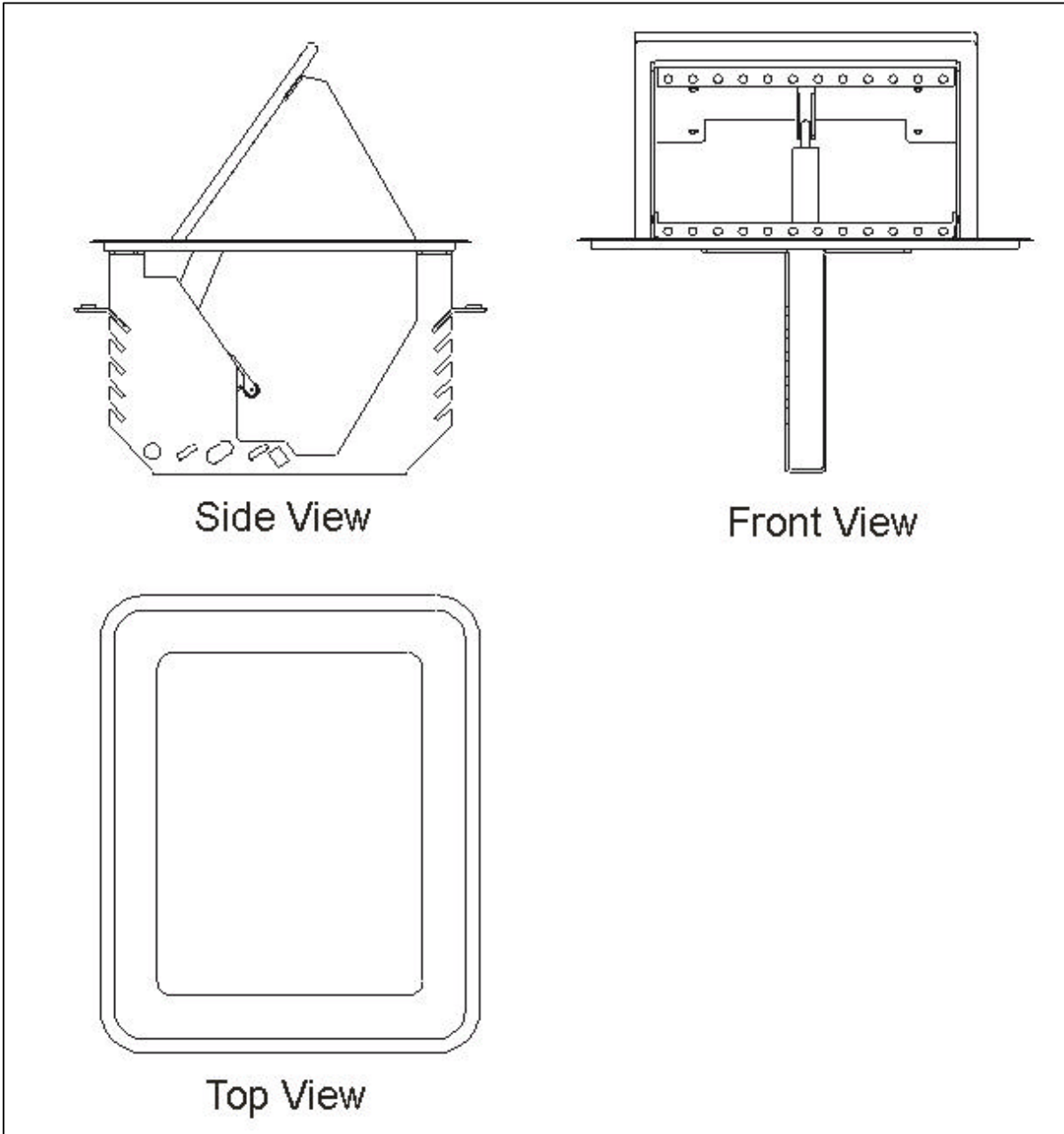

APPLICATION DIAGRAM 6

Diagram 3. Available Plates



Many different plates can be installed on TNP500. In addition to standard plates, any custom plates can be made using blank plates available. Additional description and part numbering is available on Altinex web site www.altinex.com.

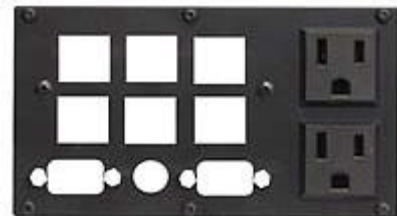

Diagram 4: Final Installation view



Diagram 5: Sample configuration with modules installed



INSTALLATION 7

Step 1. Cut an opening into the table's surface. Refer to diagram 5 on page 8 of the manual for table cutout requirements.

Note: The table can be 3 inches or thinner in thickness. Always confirm dimensions before cutting to insure that specifications have not changed.

Step 2. Insert the **TNP500** into the opening in the table.

Step 3. Place the support brackets under the table and place them between the support mount grooves on the side of the **TNP500** unit. Attach the brackets to the groove at the desired height and secure them to the bottom of the table using the 6-32 screw. There are two support brackets, one for each side of the unit. (See Figure 1)

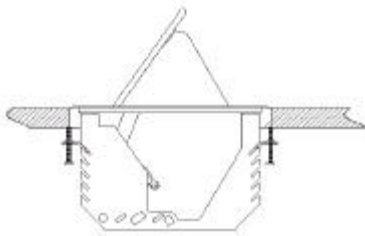

Figure 1: Attachment of the TNP500 to the table using support brackets and set screws

Step 4. Secure the cables by using the provided cable clamp (See Figure 2). Pass the power cord from the bottom of the housing and attach it to the table using the cable clamp supplied with the **TNP500** unit. Do not keep the cord too tight or too loose (See Diagram 4, page 7).



Figure 2: Cable Clamp

Step 5. Connect the appropriate cables with the correct input connectors. There are two RCA audio connectors on the front panel of the **TNP500**. The black connector is known as audio left, whereas the red connector is called audio right. There is also an RCA video connector, which is yellow in color. The network connection is red. In addition, the telephone or data connection is gray.

Step 6. Once you have applied power and connected the proper cables on the bottom of the unit, you may raise the unit. To raise the **TNP500** into position, lift the top by pulling upward at the notch in the top plate.

Step 7. To lower the unit, push on the top of the **TNP500** until it fits into place.

For more information, please refer to the FAQ Section or the Troubleshooting Guide.

OPERATION 8

8.1 HOW TO RELEASE AND REPLACE THE GAS SPRING

To replace the spring, remove retaining rings and snap spring off. Keep in mind that spring is loaded under 15lb of pressure.

FREQUENTLY ASKED QUESTIONS (FAQ) 9

No:	Question	Answer
1	Why are the VGA connectors female on both ends of the cables?	Female cables are more reliable.
2	Why is there a DB-9 connector?	The DB-9 connector is compatible with RS-232 serial communication.
3	What happens if the spring breaks?	The unit will not stay open.
4	What do I do if the TNP500 won't stay open?	Replace the gas spring. Call ALTINEX for service information.
5	How much room is taken up on the underside of the table?	The unit is 4.5 inches deep maximum below the table; to this dimension add about 2.5 inches for cable clearance.
6	What if my table is thicker than 3 inches?	Then the area under the table near the TNP500 must be reduced to 3 inches of thickness.
7	Are cables available for connecting a PC/laptop to the TNP500 available?	Consider using MS8126CA (3ft) or MS8156CA (6ft) for VGA connection.
8	Does ALTINEX honor any warranty on field modifications?	Anything modified by non-ALTINEX personnel is not covered by warranty.

CABLES AND ACCESSORIES 10

Model No.	Description
	VGA MALE TO MALE (HD-15) HIGH RESOLUTION CABLE
CB37xxMR	xx = available length of 3ft, 6ft, 15ft, 25ft, 50ft, 75ft, 100ft, 150ft
	VGA MALE TO FEMALE (HD-15) HIGH RESOLUTION CABLE
CB39xxMR	xx = available length of 3ft, 6ft, 15ft, 25ft, 50ft, 75ft, 100ft, 150ft, 200ft, 250ft
	SUPER HIGH RESOLUTION PLENUM-FLEX MULTI- CHANNEL COAX CABLE VGA MALE TO VGA MALE (HD-15)
CB5000PL-5VMxxxVM	xxx = available length of 3ft, 6ft, 15ft, 25ft, 50ft, 75ft, 100ft, 150ft, 200ft, 250ft
	SUPER HIGH RESOLUTION PLENUM-FLEX MULTI- CHANNEL COAX CABLE VGA MALE TO VGA FEMALE (HD-15)
CB5000PL-5VMxxxVF	xxx = available length of 3ft, 6ft, 15ft, 25ft, 50ft, 75ft, 100ft, 150ft, 200ft, 250ft

TROUBLESHOOTING GUIDE 11

The supplied **TNP500** unit was carefully tested and no problems were detected; however, we would like to offer the following suggestions:

- If there is no power, check to see if the circuit breaker is tripped.
- Please make sure that the highest quality video, audio, network, and telephone cables or connectors are used.
- Make sure that no cable or power cord is damaged or pinched. If there has been damage, then do not use the **TNP500** unit. Immediately contact the ALTINEX Customer Service Department to have the unit repaired.

ALTINEX POLICY

12

12.1 LIMITED WARRANTY

ALTINEX warrants that its products and cables are free from defects in materials under normal use and service. This warranty is limited to repairing at company's factory any part or parts of the product, which upon company's examination shall disclose to be, thus defective. Products considered defective should be returned to company with transportation charges pre-paid within 2 years (90 days for cables) from date of shipment to the purchaser. The warranty is expressly instead of all other warranties expressed or implied. ALTINEX neither assumes nor authorizes any other person to assume for it any other liability concerning the sale of the products. This warranty shall not apply to any product that shall have been repaired or altered outside of company's factory in any way so as, in its judgment, to affect its stability or reliability, or that has been subject to misuse, negligence, or accident.

12.2 RETURN POLICY

It is very important to ALTINEX that you receive all products that you have ordered and that this product meets your expectations. In the unlikely event that an ALTINEX product needs to be returned, please follow the policies below:

ALTINEX will accept all product returns for a period of 30 days from authorized ALTINEX dealers in an unopened package.

If a product has been opened, the restocking fees will apply. For the restocking fee, please contact an ALTINEX Sales Representative.

If the product is in your possession for more than 30 days, the restocking fees will apply.

ALTINEX will not accept any returns on cables or custom products.

If your product is in warranty and needs service, contact the ALTINEX Sales Department for an RMA (Return Material Authorization). Products returned without an RMA number may experience a delay in service.

If your product is out of warranty and needs service, contact the ALTINEX Sales Department for an RMA (Return Material Authorization). Products returned without an RMA number may experience a delay in service. The service charges will be quoted to you before the actual repairs are done.

12.3 CONTACT INFORMATION

Sales Department

Phone: 714-990-2300
Fax: 714-990-3303