



MANUAL PART NUMBER: 400-0378-001

SW1956CT

2-IN, 1-OUT CAT-5 AUTO-SWITCHER USER'S GUIDE

TABLE OF CONTENTS

	Page
PRECAUTIONS / SAFETY WARNINGS	2
GENERAL.....	2
INSTALLATION.....	2
CLEANING.....	2
FCC / CE NOTICE.....	2
ABOUT YOUR SWITCHER.....	3
TECHNICAL SPECIFICATIONS.....	3
DESCRIPTION OF SW1956CT	4
APPLICATION DIAGRAM	5
DIAGRAM 1 : TYPICAL CONNECTION.....	5
DIAGRAM 2 : INTERNAL VIEW.....	6
INSTALLING YOUR SWITCHER	7
OPERATION	7
TROUBLESHOOTING GUIDE	8
THE POWER LED IS OFF.....	8
UNIT DOES NOT AUTO-SWITCH.....	8
NO DISPLAY.....	8
ALTINEX POLICY	9
LIMITED WARRANTY/RETURN POLICY	9
CONTACT INFORMATION	9

PRECAUTIONS / SAFETY WARNINGS 1

Please read this manual carefully before using your **SW1956CT** Switcher. Keep this manual handy for future reference. These safety instructions are to ensure the long life of your **SW1956CT** and to prevent fire and shock hazard. Please read them carefully and heed all warnings.

1.1 GENERAL

- Qualified ALTINEX service personnel, or their authorized representatives must perform all service.

1.3 INSTALLATION

- For best results, place the **SW1956CT** on a flat, level surface. Keep in a dry area away from dust and moisture.
- To prevent fire or shock, do not expose this unit to rain or moisture. Do not place the **SW1956CT** in direct sunlight, near heaters or heat radiating appliances, or near any liquid. Exposure to direct sunlight, smoke, or steam can harm internal components.
- Handle the **SW1956CT** carefully. Dropping or jarring can damage internal components.
- Do not place heavy objects on top of the **SW1956CT**. If the unit is to be mounted to a table or wall, use only Altinex made mounting accessories.
- To turn off the main power, be sure to remove the cord from the power outlet. The power outlet socket should be installed as close to the equipment as possible, and should be easily accessible.
- Do not pull the power cord or any cable that is attached to the **SW1956CT** Switcher.
- If the **SW1956CT** is not used for an extended time, disconnect power cord from the outlet.

1.4 CLEANING

- Unplug the **SW1956CT** power cord before cleaning. Clean surfaces with a dry cloth. Never use strong detergents or solvents, such as alcohol or thinner. Do not use a wet cloth or water to clean the unit.

1.5 FCC / CE NOTICE

- This device complies with Part 15 of FCC Rules. Operation is subject to the following two conditions: (1) This device may not cause harmful interference, and (2) this device must accept any interference, including interference that may cause undesired operation.
- This equipment has been tested and found to comply with the limits for a Class A digital device, pursuant to Part 15 of FCC Rules. These limits are designed to provide reasonable protection against harmful interference when equipment is operated in a commercial environment. This equipment generates and uses radio frequency energy. If not installed and used in accordance with the instruction manual, it may cause harmful interference to radio communications. Operation of this equipment in a residential area is likely to cause harmful interference in which case the user will be required to correct the interference at his own expense.
- Any changes or modifications to the unit not expressly approved by Altinex, Inc. could void the user's authority to operate the equipment.

ABOUT YOUR SWITCHER

2

SW1956CT

2-In, 1 Out CAT-5 Auto-Switcher

The **SW1956CT** is a 2-In, 1-Out CAT-5 Auto-Switcher. The **SW1956CT** automatically switches on signal detection, but may also be controlled manually if desired. The **SW1956CT** is designed to switch Altinex CAT-5/6 Twisted Pair Transmitter and Receiver signals. These include Altinex part numbers **DA1920SX**, **DA1921SX**, **DA1930CT**, **DA1931CT**, **MT103-115** and **MT103-116**.

The unit is encased in a solid metal enclosure and ships with an external, 9V 500mA, power adapter. Also included is an external contact-closure switch for manual override of input selection.

Manual override switching is made via a contact closure on the INPUT SELECT jack. This switch may be used for manual control, or the contact closure may be controlled from a control system.

The **SW1956CT** is perfect for applications that use wall or floor plates for auto switching. The **SW1956CT** may be mounted to furniture or other suitable surfaces using optional hardware.

TECHNICAL SPECIFICATIONS

3

FEATURES/DESCRIPTI ON	SW1956CT
Inputs	Two
Input Connector	RJ-45 Female
Outputs	One
Output Connector	RJ-45 Female
Compatibility	Audio + VGA thru UXGA

Table 1. **SW1956CT** General

MECHANICAL	SW1956CT
Material	0.1" Al
Finish	Gray
Height (inches)	3.00in (76mm)
Width (inches)	4.38in (111mm)
Depth (inches)	1.00in (25mm)
Weight (pounds)	0.4lbs (0.18kg)
Ship Weight (pounds)	2.0lbs (0.91kg)
T° Operating	10°C-35°C
T° Maximum	50°C
Humidity	90% non-condensing
MTBF (calculations)	40,000 hrs (min.)

Table 2. **SW1956CT** Mechanical

ELECTRICAL	SW1956CT
Input Signal	
Analog Signal	1.0V p-p max
Output Video Signals	
Analog Signal	1.0V p-p max
Frequency Compatibility	
Horizontal	15-200 kHz
Vertical	20-190 Hz
Typical Video Bandwidth	350 MHz @ -3dB
Cross-talk	-40dB @10 MHz
Coupling	DC
Power	
External Power Adapter	9V 500mA (included)
Power Consumption	3 watts max.

Table 3. **SW1956CT** Electrical

3



CAT-5 INPUT1



CAT-5 INPUT2



POWER



CAT-5 OUTPUT



INPUT SELECT



APPLICATION DIAGRAM

5

DIAGRAM 1 : TYPICAL CONNECTION

Altinex provides a remote control switch with a 6 foot cable, Altinex part number **RC5203CC**, which will control the **SW1956CT** manually.

When the remote control switch is connected to the INPUT SELECT jack, INPUT 1 will be selected if the channel select contact is closed. INPUT 2 will be selected if the channel select contact is open.

The switching will be identical whether there are one or two active signals. The indicator lights located next to the input ports indicate which input is selected.

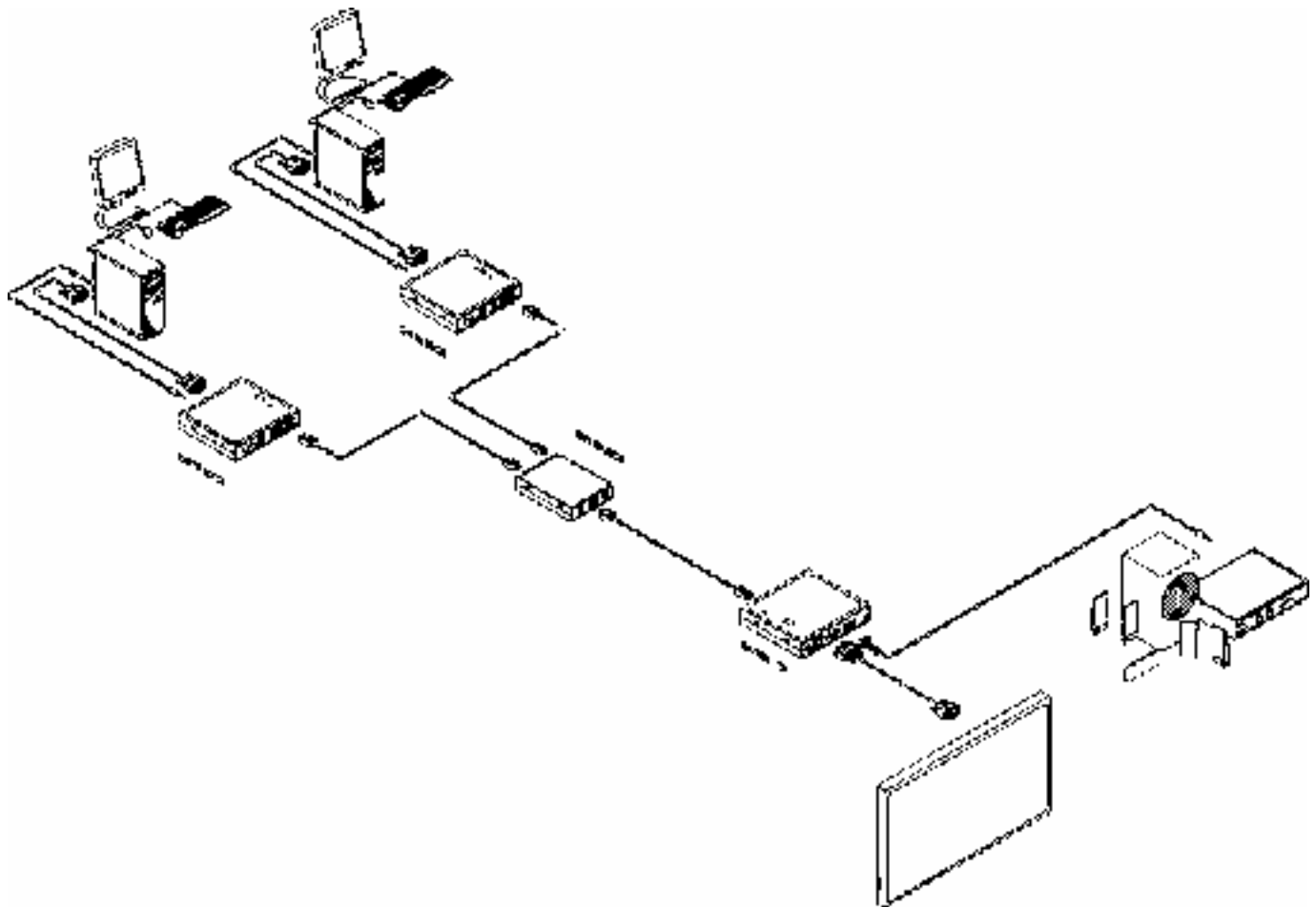
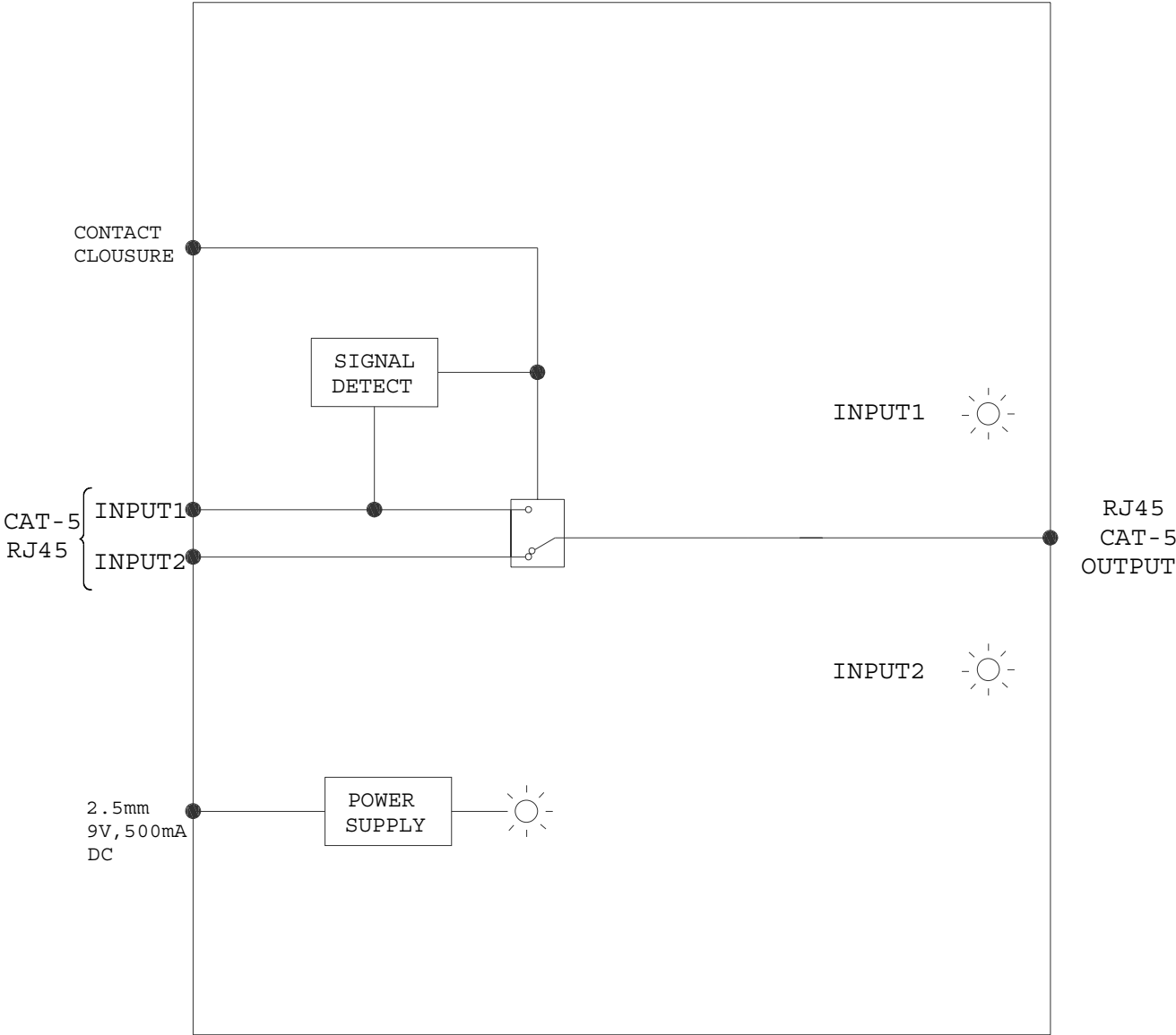

DIAGRAM 2 : INTERNAL VIEW



INSTALLING YOUR SWITCHER 6

Step 1. Make sure that the correct power adapter is used. The Altinex power adapter is supplied with the unit.

Step 2. Connect the power adapter to the power port.

CAUTION: The POWER port and the INPUT SELECT port use the same connector type. Make sure the power adapter is connected to the POWER port.

Step 3. The POWER indicator light and the INPUT 2 indicator light should turn ON.

Step 4. Connect the **SW1956CT** inputs to the outputs of the **DA1930CT** VGA+AUDIO to CAT-5/6 Transmitters.

Step 5. Connect a cable from the output port of the **SW1956CT** to the input port of the **DA1931CT** CAT-5/6 to VGA+AUDIO Receiver.

Step 6. If the remote control switch is to be used, connect the **RC5203CC** to the INPUT SELECT port.

CAUTION: The POWER port and the INPUT SELECT port use the same connector type. Make sure the control switch is connected to the INPUT SELECT port.

Step 7. Verify that the picture quality on the display is good. If a signal is not being received, make sure that the display is compatible with the resolution of the computer graphics card.

OPERATION 7

There are no settings to adjust on the **SW1956CT** Auto-Switcher. The **SW1956CT** will operate successfully as long as cables are attached properly and other technical specifications are followed.

AUTO-SWITCH MODE

The **SW1956CT** automatically selects the INPUT 2 port if there are no active signals present. If there is an active signal on INPUT 2 and not on INPUT 1, then the **SW1956CT** will maintain INPUT 2 as the active port. However, when an active signal is applied to INPUT 1, the **SW1956CT** will switch to INPUT 1.

If there are active signals on INPUT 1 and INPUT 2, the **SW1956CT** will automatically switch to INPUT 1.

MANUAL SWITCH MODE

Manual override is accomplished via a contact closure on the INPUT SELECT jack. Manual Switch Mode disables Auto-Switching.

Included with the **SW1956CT** is an external manual switch with a six foot cable, Altinex part number **RC5203CC**. This switch may be used for manual control, or the contact closure may be made from a control system. This port uses a 2.5mm mini-coaxial remote control jack and it is located next to the CAT-5 OUTPUT.

INPUT 1 will be selected when the remote control switch is connected to the INPUT SELECT jack and the contact is closed. INPUT 2 will be selected if the contact is open.

CAUTION: The connector used for the INPUT SELECT port is the same type as is used for the POWER connector. Use caution to ensure the switch is connected to the correct port.

TROUBLESHOOTING GUIDE 8

We have carefully tested and have found no problems in the supplied **SW1956CT** unit. However, we would like to offer the following suggestions:

8.1 THE POWER LED IS OFF

Cause 1: The power adapter is installed wrong.

Solution 1: Make sure the adapter output is connected to the POWER input jack on the unit. Check the unit carefully. The POWER input jack and the INPUT SELECT jack are the same type. If the POWER LED is still not on, see Solution 2.

Solution 2: Make sure the adapter is plugged into a proper AC outlet that has power. If the adapter has AC power and the POWER LED is still off, see Cause 2.

Cause 2: The wrong power adapter is installed.

Solution 1: Please use the Altinex supplied external adapter (9V, 500mA). If the POWER LED is still not on, please call ALTINEX at (714) 990-2300.

8.2 UNIT DOES NOT AUTO-SWITCH

Cause 1: The manual override switch is installed.

Solution: Remove the connection to the INPUT SELECT jack on the unit. If a plug is installed in the jack, even without a switch, the unit will not auto-switch properly. If the unit does not auto-switch with the plug removed, see Cause 2.

Cause 2: The signal is not active or is improperly formatted.

Solution 1: Remove the input signals from the switcher. If the IN 2 LED is OFF, call ALTINEX at (714) 990-2300. If the IN 2 LED is ON, see Solution 2.

Solution 2: Connect a properly formatted signal from an Altinex CAT-5/6 Transmitter to INPUT 1. If the switcher does not switch to INPUT 1, see Solution 3.

Solution 3: Bypass the switcher and connect the output of the transmitter directly to the input of the receiver. If the display is good, then call ALTINEX at (714) 990-2300.

8.3 NO DISPLAY

Cause 1: The source has a problem.

Solution: Check the source and make sure that there is a signal present and all source connections are correct. If the source is working and there is still no display, see Cause 2.

Cause 2: Manual override is ON.

Solution: Make sure there is nothing connected to the INPUT SELECT port on the switcher. If there is nothing connected, see Cause 3.

Cause 3: Signal is bad or missing.

Solution 1: Make sure the switcher output is connected to the CAT-5/6 Receiver input and the receiver is ON. If there is still no display, see Solution 2.

Solution 2: Remove both inputs to the switcher and connect the active signal from the CAT-5/6 Transmitter output to INPUT 2. If there is still no display, see Solution 3.

Solution 3: Bypass the switcher and connect the output of the transmitter directly to the input of the receiver. If the display is good, then call ALTINEX at (714) 990-2300. If there is still no display, see Cause 4.

Cause 4: Cable connections are incorrect.

Solution: Make sure that cables are properly connected. Also, make sure that the continuity and wiring are good. If there is still no display present, see Cause 5.

Cause 5: The display has a problem.

Solution: Make sure the display has power and is turned ON. If there is still no display, please call Altinex at (714) 990-2300.

ALTINEX POLICY

9

9.1 LIMITED WARRANTY/RETURN POLICY

Please see the Altinex website at www.altinex.com for details on warranty and return policy.

9.2 CONTACT INFORMATION

ALTINEX, INC

592 Apollo street

Brea, CA 92821 USA

TEL: 714 990-2300

TOLL FREE: 1-800-ALTINEX

WEB: www.altinex.com

E-MAIL: solutions@altinex.com