

MANUAL PART NUMBER: 400-0099-001
PRODUCT REVISION: 0

MX2456RM

6-IN, 1-OUT VGA & AUDIO SWITCHER USER'S GUIDE

TABLE OF CONTENTS

	Page
PRECAUTIONS / SAFETY WARNINGS	2
GENERAL	2
RACK MOUNT SAFETY GUIDELINES	2
INSTALLATION	2
CLEANING	2
FCC / CE NOTICE	2
ABOUT YOUR MX2456RM	3
TECHNICAL SPECIFICATION	3
DESCRIPTION OF MX2456RM	4
VIDEO SELECT MODE	5
AUDIO BREAK AWAY MODE	5
EQUALIZATION MODE	5
AUTO SWITCH MODE	5
AUTO ROTATION MODE	5
AUDIO VOLUME CONTROL	5
SYNC DELAY MODE	5
RESET MODE	5
FACTORY RESET MODE	5
APPLICATION DIAGRAM	6
INSTALLING YOUR MX2456RM	7
OPERATION	7
CONTROL PANEL	7
RS-232 CONTROL	8
ACCESSORIES	12
FREQUENTLY ASKED QUESTIONS	13
TROUBLESHOOTING GUIDE	13
ALTINEX POLICY	14
LIMITED WARRANTY	14
RETURN POLICY	14
CONTACT INFORMATION	14

PRECAUTIONS / SAFETY WARNINGS 1

Please read this manual carefully before using your **MX2456RM** Switcher. Keep this manual handy for future reference. These safety instructions are to ensure the long life of your **MX2456RM** and to prevent fire and shock hazard. Please read them carefully and heed all warnings.

1.1 GENERAL

- Unauthorized personnel shall not open the unit since there are high-voltage components inside.
- Qualified ALTINEX service personnel, or their authorized representatives must perform all service.

1.2 SAFETY GUIDELINES FOR THE RACK-MOUNTING OF THE MX2456RM

- Maximum operating ambient temperature is 35 (degrees C).
- Never restrict the air flow through the devices' fan or vents.
- When installing equipment into a rack, distribute the units evenly. Otherwise, hazardous conditions may be created by an uneven weight distribution.
- Connect the unit to a properly rated supply circuit.
- Reliable Earthing (Grounding) of Rack-Mounted Equipment should be maintained.

1.3 INSTALLATION

- For best results, place the **MX2456RM** Switcher on a flat, level surface in a dry area away from dust and moisture.
- To prevent fire or shock, do not expose this unit to rain or moisture. Do not place the **MX2456RM** Switcher in direct sunlight, near heaters or heat radiating appliances, or near any liquid. Exposure to direct sunlight, smoke, or steam can harm internal components.
- Handle the **MX2456RM** Switcher carefully. Dropping or jarring can damage internal components.

- Do not place heavy objects on top of the **MX2456RM**. If the **MX2456RM** is to be mounted to a table or wall, use only ALTINEX-made mounting accessories, such as rack mount shelf **DA1298RM** or rack mount ears **DA1292FC** and cables for optimum setup.
- To turn off the main power, be sure to remove the cord from the power outlet. The power outlet socket should be installed as near to the equipment as possible, and should be easily accessible.
- Do not pull the power cord or any cable that is attached to the **MX2456RM** Switcher.
- If the **MX2456RM** Switcher is not used for an extended period, disconnect the power cord from the power outlet.

1.4 CLEANING

- Unplug the **MX2456RM** power cord before cleaning. Clean surfaces with a dry cloth. Never use strong detergents or solvents, such as alcohol or thinner. Do not use a wet cloth or water to clean the unit.

1.5 FCC / CE NOTICE

- This device complies with part 15 of the FCC Rules. Operation is subject to the following two conditions: (1) This device may not cause harmful interference, and (2) this device must accept any interference received, including interference that may cause undesired operation.
- This equipment has been tested and found to comply with the limits for a Class A digital device, pursuant to Part 15 of the FCC Rules. These limits are designed to provide reasonable protection against harmful interference when the equipment is operated in a commercial environment. This equipment generates, uses, and can radiate radio frequency energy and, if not installed and used in accordance with the instruction manual, may cause harmful interference to radio communications. Operation of this equipment in a residential area is likely to cause harmful interference in which case the user will be

required to correct the interference at his own expense.

- Any changes or modifications to the unit not expressly approved by ALTINEX, Inc. could void the user's authority to operate the equipment.

ABOUT YOUR MX2456RM 2

The **MX2456RM** is a video and audio switcher with six VGA inputs, which can be connected to a single VGA output and six stereo or balanced audio inputs, which can be connected to a single stereo or balanced audio output. It allows the non-simultaneous connection of up to six computers or six video and six audio sources to a monitor or projector and to any audio system.

The **MX2456RM** can pass a variety of video signal types: RGBHV, RGBS, RGsB, Component Video (Y, R-Y, B-Y), S-Video and Composite Video. The **MX2456RM** is controllable by using its built-in front panel or through RS-232.

Each of the VGA inputs is ground loop isolated and can promote individual equalization of video gain according to different cable lengths.

The **MX2456RM** has a video bandwidth of 300 MHz and an audio bandwidth of 40 kHz.

TECHNICAL SPECIFICATION 3

FEATURES/DESCRIPTION	Audio	RGBHV
GENERAL		
Inputs	6	6
Input Connector	Six 5 conductor terminal blocks	Six 15-pin HD-F
Outputs	1	1
Output Connector	One 5 conductor terminal block	One BNC Female
Compatibility	Stereo or balanced audio	VGA, RGBHV, RGBS, RGsB, & C-Video (Y, R-Y, B-Y)

Table 1. **MX2456RM** General

MECHANICAL	MX2456RM
Width (inches)	1.75in (44mm)
Height (inches)	17.00 in (432mm)
Depth (inches)	9.00in (229mm)
Weight (pounds)	5lbs (2.28kg)
Finish	Gray
Front/Rear Panel	Lexan
T° Maximum	50°C
Humidity	90% non-condensing
MTBF (calculations)	40,000 hrs (min)

Table 2. **MX2456RM** Mechanical

ELECTRICAL	Audio	RGBHV
Input Signal		
Differential	1.8V p-p	-
Analog	-	1.2V p-p
Composite Video	-	-
Impedance	10 k Ohms	75 Ohms
CMRR	80dB @ 10 Hz to 20k Hz	-
Input Sync Signals		
Composite, Horizontal, & Vertical	-	TTL (+/-)
Output Signals		
Analog	-	1.2V p-p
Fall/ Rise Time	-	less than 2.4ns
Impedance	600 Ohms	75 Ohms
Crosstalk	80 dB @ 1kHz	-48dB @ 10 MHz
Differential	1.8Vp-p	-
Signal to Noise Ratio	More than 95 dB	-
Bandwidth	10 Hz – 40 kHz	300MHz
Stereo Signal Separation	More than 60dB @ 20 kHz	-
Output Sync Signals		
Impedance	-	22 Ohms
Power		
External Power	90V AC to 260V AC 50/60Hz	
Power Consumption	14 watts max.	

Table 3. **MX2456RM** Electrical

DESCRIPTION OF MX2456RM

4

FRONT PANEL

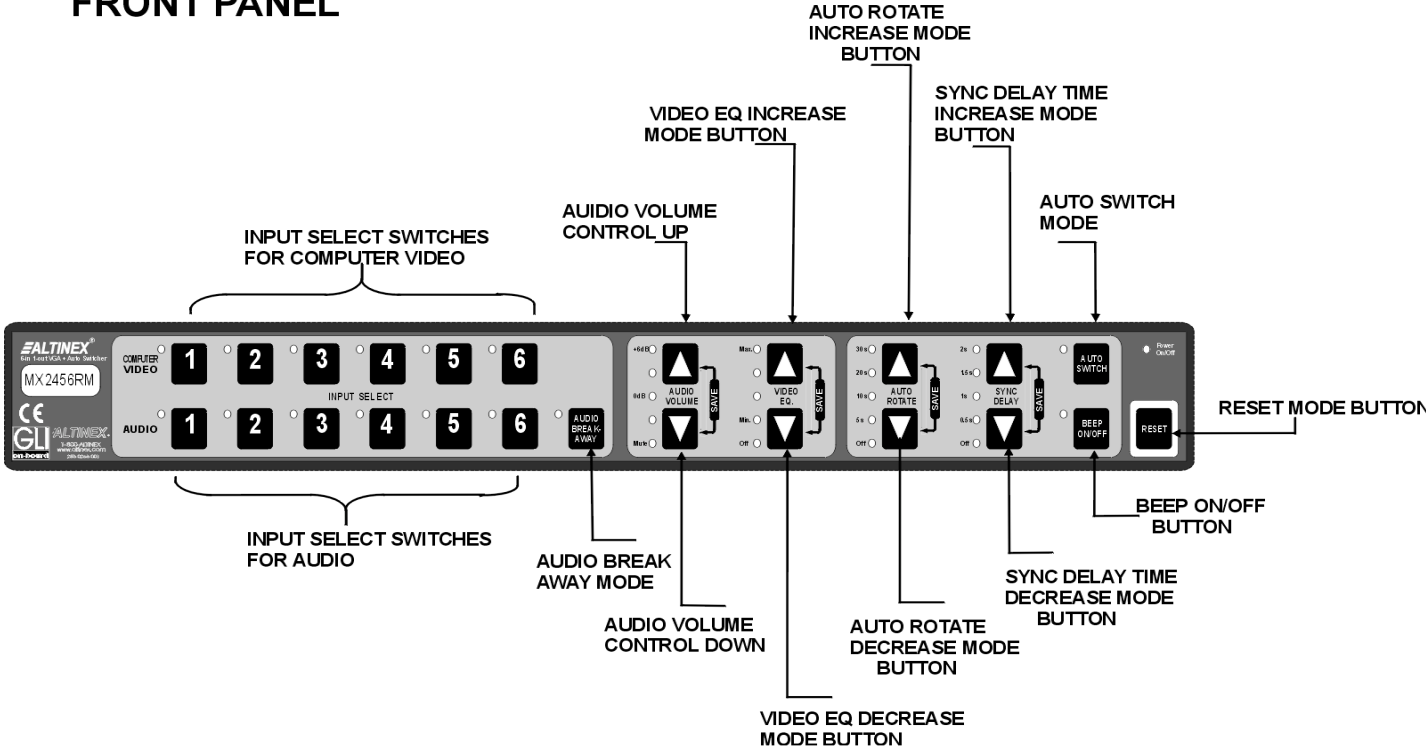

REAR PANEL

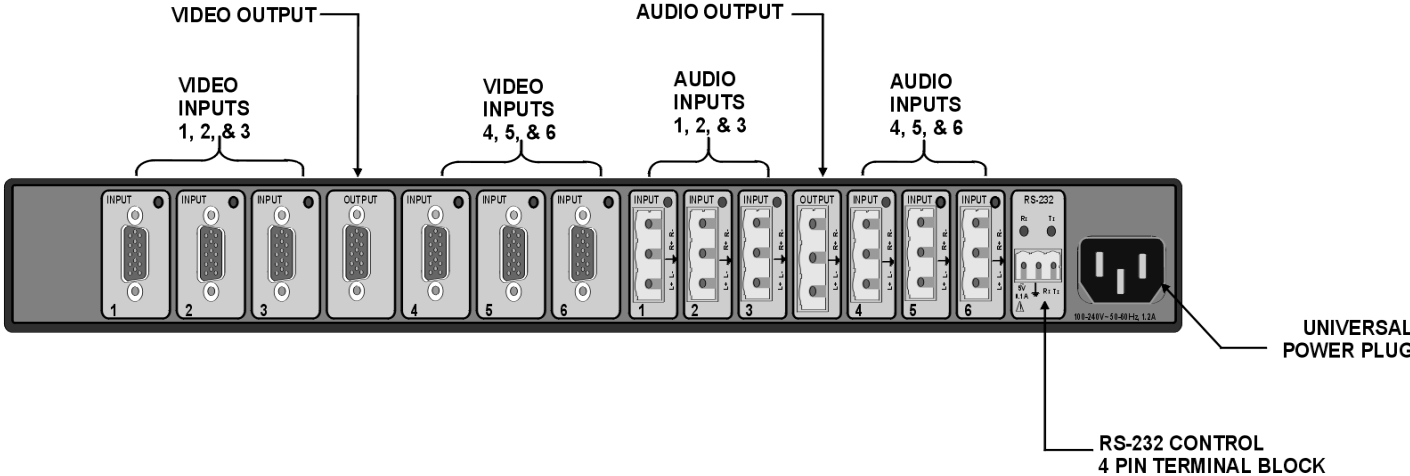

There are two sections on the front panel of the **MX2456RM**: input select and switcher control. The buttons within the input select section allow for the actual switching of the source signals. The buttons within the switcher control section allow access to the switcher setup features.

4.1. VIDEO SELECT MODE

Default video and audio inputs connect to video and audio outputs simultaneously, but if needed the user may select video and audio inputs separately using AUDIO BREAK AWAY mode. The user can select any video input by using the input select buttons located on the front panel.

4.2. AUDIO BREAK AWAY MODE

This mode allows independent selection of video and audio inputs. After selecting AUDIO BREAK AWAY mode, the user may select any audio input for switching when the power is turned ON.

4.3. EQUALIZATION MODE

Video signals are connected from input to output through a video amplifier along with an equalization circuit. This allows the user to equalize video signals for each of the inputs according to the distance (cable length) from the video source (PC) to the switcher.

4.4. AUTO SWITCH MODE

If AUTO SWITCH mode is turned ON, the input which was previously selected by the incoming video signal will connect to the output automatically.

If the user does not previously select the AUDIO BREAK AWAY mode, the same number of audio inputs will be connected to the audio output.

4.5. AUTO ROTATION MODE

The user may select AUTO ROTATION mode with a preset rotation time. If this mode is selected, then all video inputs connected to the video output will be selected alternately. Audio inputs will simultaneously connect to the audio output along with video inputs if the user did not previously select AUDIO BREAK AWAY mode.

4.6 AUDIO VOLUME CONTROL MODE

This button allows the user to control the audio volume using the UP or DOWN buttons. To increase the volume, push the UP button and to decrease the volume, push the DOWN button.

4.7. SYNC DELAY MODE

The default SYNC DELAY mode button in the "OFF" position means that the video portion of the video signal and the sync portion of the video signal are connected to the output simultaneously. The **MX2456RM** Switcher can operate in SYNC DELAY mode to avoid a "glitch" effect typically associated with switching between video sources. Sync delay time is the amount of time when sync is connected to the output before the video portion of the video signal is transmitted. The user may select a time from 0.5 seconds to 2 seconds.

4.8. BEEP ON/OFF MODE

If the BEEP ON/OFF mode is selected, each control on the control panel, except the RESET mode will be without an accompanying beeper sound.

4.9. RESET MODE

RESET mode sets the memory, which was previously set by the factory and resets the Switcher. To reset the switcher, press the RESET button. In RESET mode, video input 1 and audio input 1 will be active. AUTO SWITCH mode will be disabled if previously active. BEEP ON/OFF mode will return to the ON position if previously in the OFF position. The RESET mode button does not affect Audio Volume, Video Equalization, Auto Rotate or the Sync Delay mode.

4.10 FACTORY RESET MODE

This mode clears all data from memory, which was previously set by the user and returns the switcher to the factory-preset position. To return the switcher to the FACTORY PRESET mode, turn OFF the power, press the RESET button, turn power ON and then release the RESET button.

APPLICATION DIAGRAM

5

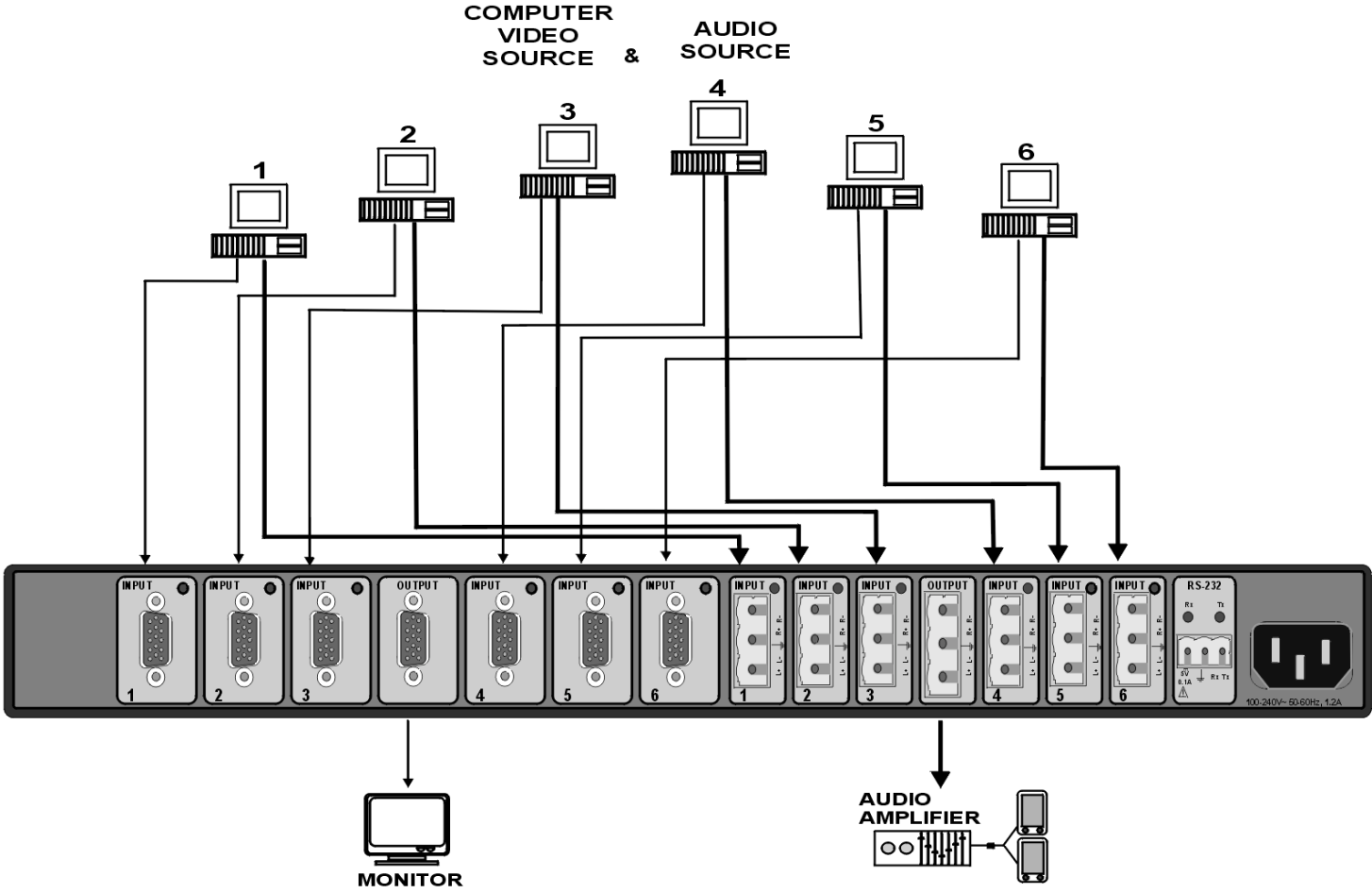

*Dark arrows represent audio cables
*Light arrows represent video cables

INSTALLING YOUR MX2456RM 6

- Step 1.** Make sure that the power input is set to the proper AC voltage for the country of usage. An incorrect setting may result in unit damage not covered by warranty.
- Step 2.** Connect the power cord to the unit and plug it into the power outlet.
- Step 3.** Connect the cables from the video sources and the audio sources (computers, VCR, etc.) to the input channels and connect the display devices (monitor or projector) and the appropriate audio equipment (mixer, amplifier, etc.) to the outputs. For better results use shielded, high-quality coaxial cables.
- Step 4.** Test all the required switching features. If you experience difficulties or abnormal switching, you may wish to reset the unit to the factory defaults to make sure that you have not entered an incorrect operation mode. To reset the switcher, turn the power ON and OFF. Then turn the power ON again while pressing and holding the "RESET" button. After a brief delay, all LED's should blink ON and OFF. A beeping sound will be heard several times indicating that the switcher has been factory reset.
- Step 5.** Verify that the display and audio equipment operates properly and results in perfect images and sound.

OPERATION 7

7.1 CONTROL PANEL

1. When a button is pressed and released a beeper will sound once. If a button is pressed and held, a beeper will sound several times.
2. Default video and audio inputs are selected simultaneously by pressing and releasing one of the video input buttons. LED's that represent selected inputs on the control panel and connector board should turn ON.
3. When selecting audio inputs and video inputs independently, press the AUDIO BREAK AWAY mode button. If at any time you need to return the **MX2456RM** Switcher to the previous mode position, press the AUDIO BREAK AWAY mode button.
4. Before setting the VIDEO EQ mode, you must determine the length of cable that is connected to each of the video inputs. To select the appropriate equalization, follow steps a-d below.
 - a) Select Video Input
 - b) Press and release the VIDEO EQ UP button as many times as needed to turn the video equalizer to the correct position. Each time this button is pressed, it equalizes for the next 25 ft of cable. (For equalization of 100ft of cable, press the button four times; for cable 150ft, press button six times; and for cable 375ft, press the button fifteen times and so on.)
 - c) To set the selected equalization to memory, press and hold the VIDEO EQ UP and DOWN buttons simultaneously for 2 seconds.
 - d) Repeat step b and c for equalization of any video input.
5. To set the AUTO ROTATE mode, use the AUTO ROTATE Up and Down buttons to select the appropriate rotation time. Video inputs will rotate as they connect to the output within the selected auto rotation time. Audio inputs will also rotate, if AUDIO BREAK AWAY mode was not previously selected. Equalization is still active.

6. If necessary, select the SYNC DELAY UP or DOWN button. To activate and set the SYNC DELAY mode to memory, press and hold the UP or DOWN button. LED's that represent the selected time should light.
7. To activate the AUTO SWITCH mode, press the AUTO SWITCH button. The LED that represents the AUTO SWITCH mode should light. If the AUTO ROTATE mode was selected previously, it will cancel. Audio inputs will follow video inputs if the AUDIO BREAK AWAY mode was not selected previously.
8. The AUDIO VOLUME mode will control the audio stereo volume when the VOLUME UP or DOWN button is pressed and released. The AUDIO VOLUME UP or DOWN button is between a maximum volume of +6dB and a minimum volume of -6dB. From the minimum to maximum volume, there are fifteen points. Each point represents 0.8dB. After selecting the volume, press and hold the UP and DOWN buttons simultaneously.
9. To turn OFF the beeping sound, press and hold the BEEP ON/OFF button. The LED that represents this button should light. To activate sound, press and hold the BEEP ON/OFF button again.
10. To return the switcher to factory preset, press the RESET button. After a brief delay, all LED's should blink ON and OFF. A beeping sound will be heard several times indicating that the switcher has been reset.

7.2 RS-232 CONTROL

The **MX2456RM** Switcher offers remote control capabilities through RS-232; the primary communication standard used by control systems and computers.

In fact, the **MX2456RM** offers more features using RS-232 than are currently available from the front panel of the unit.

The **MX2456RM** offers a terminal block using solder-free, screw-down contacts, making it extremely easy to connect the switcher to a control system or a computer in the field.

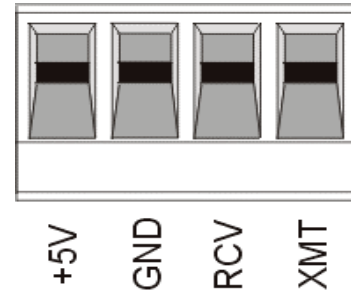

Figure 1. RS-232 Terminal Block

PIN No.	PIN Designation
1	+5V (not needed for RS-232 connection)
2	GND (Ground)
3	RCV (Receive)
4	XMT (Transmit)

Table 4. PIN Designations

The terminal block is labeled with the appropriate contact designations: Transmit (XMT), Receive (RCV), and Ground (GND). Always remember that the Transmit pin from the control system or computer must be connected to the Receive pin on the switcher control port; do not connect Transmit to Transmit or Receive to Receive.

Note: the contact labeled +5V is not used for RS-232 connections. This contact is used to provide DC voltage to other equipment installed within close proximity of the **MX2456RM**.

Typically, a control system or computer will offer RS-232 connections on a 9-pin D connector.

The following are typical cable pin-out designations for RS-232 connections on a 9-pin D connector. Always verify that the pin-outs for your system are correct to ensure the proper wiring.

IBM PIN No.	MX2456RM Contact
3	RX
2	TX
7	GND

Connection of IBM-PC 25-pin D to the **MX2456RM** Terminal Block

IBM PIN No.	MX2456RM Contact
2	TX
3	RX
5	GND

Connection of IBM-PC 9-pin D to the **MX2456RM** Terminal Block

Port setting preferences for the control system or computer being used to control the switcher should be set as follows:

BAUD RATE (Bits per second)	9600
Data bits	8
Parity	None
Stop Bits	1

7.2.1 RS-232 PROTOCOL

The RS-232 protocol for the **MX2456RM** Switcher uses a simple ASCII character format.

1. **Square brackets “[” & “]” are part of the command.**
2. **Use uppercase letters for all commands.**
3. **Make sure that the transmit pin of the control system is connected to the receive pin of the switcher and connection done as per Table 5.**
4. **Make sure that there is a delay of 50 ms between two consecutive commands.**

The factory default settings is 9600 baud, 8 bits, 1 stop, and no parity. There is no software or hardware flow control implemented.

The **MX2456RM** Switcher requires 50ms of processing time after each command is sent. So, please keep a 50ms delay between two consecutive commands.

The RS-232 input has a 16-character buffer and will not execute any command longer than 16-characters. Any additional commands are ignored until the previous command is fully processed. After processing a valid command, an [OK] string will be returned if requested by the feedback command.

7.2.2 PROGRAMMING COMMANDS

NOTE:

These programming commands are used for programming the switcher; they should not be used as part of a program to operate the switcher. The programming setting changes done through these commands are stored in a non-volatile memory. Typically, these commands can be issued 10,000 times before the memory needs to be replaced.

1. [# SW n1 n2 n3 n4 n5 n6] - Video Switch Input

This is the main command of the video input Switcher. The **[# SW n1 n2 n3 n4 n5 n6]** command contains all the information needed by the switcher to activate the video sources that are connected to the unit.

= Switch number (No. from 1 to 9, Default = 0)

n1 = Video input number (No. from 0 to 6)

n2 = Break Away code (0 = On , 1 = OFF)

n3 = 0 (video key pressed)

n4 = Sync Delay (No. from 0 to 4)

n5 = Video Equalizer (Hexadecimal No. from 0 to F)

n6 = Audio Gain (Hexadecimal No. from 0 to F)

Example:

Sending the **[8SW61040F]** command will activate switcher module 8, video input number 6 and audio input 6. Since the break away code is 1, the zero (0) alerts the switcher that the video key was pressed. The video key has an interval of 4 (2 seconds). The video equalizer is OFF, and the maximum volume is F. Zero means OFF, and the default is 8 for normal volume or video.

2. [# SW n1 n2 n3 n4 n5 n6] - Audio Switch Input

This is the main command of the audio input switcher, which contains all the information

needed by the switcher to activate the audio sources that are connected to the unit.

= Switch number (No. from 1 to 9, default = 0)

n1 = Audio input number (No. from 0 to 6)

n2 = Break Away code (0 = On , 1 = OFF)

n3 = 1 (audio key pressed)

n4 = Sync Delay (No. from 0 to 4)

n5 = Video Equalizer (Hexadecimal no. from 1 to F).

n6 = Audio Gain (Hexadecimal no. from 1 to F).

Example:

Sending the **[8SW6012F8]** command will activate switcher module **8** and audio input **6** only. Since the break away code is zero (**0**), **1** alerts the switcher that the audio key was pressed with an interval of **2** (**1** second). The video equalizer is set to a maximum and a normal volume of **8** (0 = OFF, default is 8 for normal volume or video).

3. [#RF] - Factory Reset

This command will replace all settings stored in the memory of the switcher module. This is indicated by the factory default settings. All previous settings will be lost.

= switch number (default is 0)

Example:

Sending the command **[8RF]** command will reset the Switcher module to the factory settings with ID number eight.

4. [#RO] - Operation Reset

The **[#RO]** command will reset audio and video to input #1, Auto Switch to OFF and Beep OFF to Beep ON. However, this command will not affect audio volume, video equalization, auto rotation, and sync delay.

= Switch number (Default no. is 0)

Example:

Sending the **[8RO]** command resets the switcher module in the Reset Mode with ID number eight.

5. [# SA n] - Audio Breakaway

This command controls how audio and video input are selected. The **[# SA n]** command allows the user to control audio input and video input independently or simultaneously.

= switch number (Default no. is 0)

n = 1 (ON) Breakaway Audio Input from Video Input and switchers can be activated independently.

n = 0 (OFF). In this mode the switchers are activated simultaneously. For example, if Video Input 2 is pressed Audio Input 2 will be pressed automatically.

Example:

Sending the **[1SA1]** command will allow the user to press Audio Input or the Video Input independently.

6. [#CSDn] - Sync Delay

This command allows time delay between switching from one video source to another by avoiding an overlap of communication problems.

= Switcher module ID number (Default is 0)

n = the time delay interval between video sources and switching inputs

n = 0	Sync Delay is Off (no delay)
n = 1	0.5 second delay
n = 2	1.0 s
n = 3	1.5 s
n = 4	2.0 s

Example:

Sending the **[8CSD4]** command sets a 2-second time delay between input selection of the connected switcher module with an ID number of 8.

7. [#Bn] - Beep ON/OFF

This command activates or deactivates the beeping sound when a key is pressed on the switcher module.

= Switcher module ID number (Default is 0)

n = ON/OFF switch

n = 1, turns switcher Beep ON

n = 0, turns switcher Beep OFF

Example:

Sending the **[8B1]** command sets the beeper to the ON position in the connected Switcher module with an ID number of eight.

8. [OASn] - Auto Switch

The **[OASn]** command sets the switcher module to the ON position to detect incoming audio or video signals automatically. Using this command, the user may also operate the switcher manually.

n = ON/OFF switch

n = 1 (turns auto switcher ON)

n = 0 (turns auto switcher OFF)

Example:

Sending the **[OAS1]** command will set the auto switch feature to the ON position to detect the incoming video signal automatically.

9. [0I#] - Change Identification Number

This command sets a unique ID number to each **MX2456RM** Switcher being used. A maximum of 9 unit ID's can be assigned.

0 = Zero

= New switcher module ID number. (no. from 1 to 9)

Example:

Sending the command **[0I8]** will reset the active Switcher module with a new ID number eight.

In addition, by default the switchers still have an ID number of zero.

10. [#CA n1 n2] - Audio Gain Control Save Settings

This command will save the volume settings for a specified audio input.

= Switch number (No. from 1 to 9, Default is 0)

n1 = Audio input number (No. from 0 to 6)

n2 = Audio Gain (Hexadecimal no. from 1 to F).

Example:

After executing the **[8CA6F]** command, switcher module **8** and audio input number **6** will have a maximum volume of **F** (0 = OFF, default is 8 or normal volume).

11. [#CA n1 n2] – Video Equalization Save Settings

This command saves the settings of the equalized video signal to compensate for cable distance from the video source to the switcher.

= Switch number (Default is 0. No. from 1 to 9).

n1 = Video input number (No. from 0 to 6).

n2 = Video equalization (Hexadecimal no. from 1 to F).

Example:

After executing the **[8CA58]** command, switcher module **8** and video input number **5** will have a medium equalization range of **8** (0 = OFF).

12. [#VR] - Firmware Version

This command displays the firmware revision number installed into the microprocessor.

= Switch number (No. from 1 to 9. Default is 0).

Example:

After executing the **[8VR]** command, the system will return the version number 8R1.0. If the user sends the **[0VR]** command, the system will return the version number 8R1.0.

If multiple switchers are used, this command sets a unique ID number for each of the **MX2456RM** Switchers. Multiple switcher modules can be controlled through a single RS-232 port.

In order to control multiple modules independently with one RS-232 port, the unit ID must be used. Setting the unit ID allows the user to send the same command to multiple modules, but the module processes that command with the indicated ID number only. The factory default unit ID is 1.

ACCESSORIES 8

Model No.	Description
	TABLE MOUNT HARDWARE
TM1276	Table Mount bracket for 2U ½ Rack-Wide
	RACK MOUNTING ACCESSORIES
DA1298RM	Rack mount shelf for two units side by side
DA1292RM	Rack mount ears for single unit.
	HIGH RESOLUTION 5 BNC to 5 BNC COAXIAL CABLE
CB4200MR	Bulk Cable 5 coaxes (500ft minimum)
CB4203MR	3 feet, 5 BNC to 5 BNC coaxial cable
CB4206MR	6 feet, 5 BNC to 5 BNC coaxial cable
CB4212MR	12 feet, 5 BNC to 5 BNC coaxial cable
CB4225MR	25 feet, 5 BNC to 5 BNC coaxial cable
CB4250MR	50 feet, 5 BNC to 5 BNC coaxial cable
CB4275MR	75 feet, 5 BNC to 5 BNC coaxial cable
CB42100MR	100 feet, 5 BNC to 5 BNC coaxial cable
CB42150MR	150 feet, 5 BNC to 5 BNC coaxial cable
	SUPER HIGH RESOLUTION 5 BNC to 5 BNC COAX
CB4400MR	Bulk Cable 5 coaxes (500ft minimum)
CB4406MR	6 feet, 5 BNC to 5 BNC coaxial cable
CB4412MR	12 feet, 5 BNC to 5 BNC coaxial cable
CB4425MR	25 feet, 5 BNC to 5 BNC coaxial cable
CB4450MR	50 feet, 5 BNC to 5 BNC coaxial cable
CB4475MR	75 feet, 5 BNC to 5 BNC coaxial cable
CB44100MR	100 feet, 5 BNC to 5 BNC coaxial cable
CB44150MR	150 feet, 5 BNC to 5 BNC coaxial cable
	POWER CABLES
PC5301US	Power cable for US
PC5302US	Power cable for UK
PC5303US	Power cable for Australia
PC5304US	Power cable for Germany

FREQUENTLY ASKED QUESTIONS 9

No:	Question	Answer
1.	How do I know which input is connected to which output?	LED's that represent connected video and audio sources will light.
2.	Can the MX2456RM be rack mounted?	Yes, the MX2456RM can be rack mounted by itself or with two units side by side. The width of the unit is 1-U high. ALTINEX offers rack mount ears for single unit mounting (part # DA1292RM) and rack shelf for mounting two units (part # DA1298RM).
3.	How is the MX2456RM controlled?	Control can be made through RS-232 or through the connector panel.
4.	Why is sync delay switching useful?	It eliminates the glitch normally associated with switching between high-resolution RGB type sources. This is accomplished by disconnecting the sync portion of a signal before the incoming video—making the glitch take place off-screen. The Sync Delay feature is only designed to work with RGBS and RGBHV signal formats.
5.	Can the MX2456RM Switcher be used outside of the United States?	Yes, the MX2456RM uses a universal internal power supply, enabling it to be used throughout the world. Please make sure to use the proper adapter cables for the country of usage. Adapter cables for several countries are available through ALTINEX.

TROUBLESHOOTING GUIDE 10

- Please make sure, that input signal formats are the same for the input (source) and the output (display).
- Please make sure that the input signal amplitude levels are as follows:
 1. RED, GREEN, and BLUE channels are less than 1.5V p-p.
 2. SYNC is the TTL level.
 3. Please use the appropriate input voltage 90 VAC to 260 VAC.
- Please make sure that the proper quality of cables is used. We recommended ALTINEX-made cables for the best results.
- If a problem arises after continuous usage at higher voltage, higher temperature, higher humidity, or at other extreme environmental conditions, please correct the problem.
- If a problem exists with the **MX2456RM** Switcher, please reset the unit by pressing the RESET mode button for more than 2 seconds.

11.1 LIMITED WARRANTY

ALTINEX warrants that its products and cables are free from defects in materials under normal use and service. This warranty is limited to repairing at company's factory any part or parts of the product, which upon company's examination shall disclose to be, thus defective. Products considered defective should be returned to company with transportation charges pre-paid within 2 years (90 days for cables) from date of shipment to the purchaser. The warranty is expressly instead of all other warranties expressed or implied. ALTINEX neither assumes nor authorizes any other person to assume for it any other liability in connection with the sale of the products. This warranty shall not apply to any product that shall have been repaired or altered outside of company's factory in any way so as, in its judgment, to affect its stability or reliability, or that has been subject to misuse, negligence or accident.

11.2 RETURN POLICY

It is very important to ALTINEX that you receive the products that you have ordered and that this product fulfills your need. In the unlikely event, that an ALTINEX product needs to be returned please follow the policies below:

Altinex will accept product returns for a period of 30 days from authorized ALTINEX dealers. Products should be returned in an unopened package.

If a product has been opened, the restocking fees will apply. For the restocking fee amount, please contact an ALTINEX Sales Representative.

If the product is in your possession for more than 30 days, the restocking fees will apply.

ALTINEX will not accept any returns on cables or custom products.

If your product is in warranty and needs service, contact the ALTINEX Sales Department for an RMA (Return Material Authorization). Products returned without an RMA number may experience a delay in service.

If your product is out of warranty and needs service, contact the ALTINEX Sales Department for an RMA (Return Material Authorization). Products returned without an RMA number may experience a delay in service. The service charges will be quoted to you before the actual repairs are done.

11.3 CONTACT INFORMATION

ALTINEX, Inc.

Tel:	714-990-2300
Toll Free:	1-800-ALTINEX
Fax:	714-990-3303
E-mail:	solutions@altinex.com
Web:	www.altinex.com