

**Mult
Tasker™**

MANUAL PART NUMBER: 400-0201-001

MT104-104

6-IN VGA SWITCHER EXPANSION

CARD FOR MULTI-TASKER™

ENCLOSURES USER'S GUIDE

TABLE OF CONTENTS

	Page
PRECAUTIONS / SAFETY WARNINGS	2
GENERAL	2
INSTALLATION.....	2
CLEANING.....	2
FCC / CE NOTICE.....	2
ABOUT YOUR MT104-104	3
TECHNICAL SPECIFICATIONS.....	3
PRODUCT DESCRIPTION	4
APPLICATION DIAGRAM	4
APPLICATION 1.....	4
APPLICATION 2.....	5
INSTALLING YOUR MT104-104	6
OPERATION	6
RS-232 CONTROL.....	6
RS-232 INTERFACE	6
DESCRIPTION OF COMMANDS	6
SUMMARY OF COMMANDS	10
TROUBLESHOOTING GUIDE	10
ALTINEX POLICY	12
LIMITED WARRANTY.....	12
RETURN POLICY	12
CONTACT INFORMATION	12



PRECAUTIONS / SAFETY WARNINGS 1

Please read this manual carefully before using your **MT104-104**. Keep this manual handy for future reference. These safety instructions are to ensure the long life of your **MT104-104** and to prevent fire and shock hazard. Please read them carefully and heed all warnings.

1.1 GENERAL

- Qualified ALTINEX service personnel, or their authorized representatives must perform all service.

1.2 INSTALLATION

- To prevent fire or shock, do not expose this unit to rain or moisture. Do not place the **MT104-104** in direct sunlight, near heaters or heat radiating appliances, or near any liquid. Exposure to direct sunlight, smoke, or steam can harm internal components.
- Handle the **MT104-104** carefully. Dropping or jarring can damage the card.
- Do not pull the cables that are attached to the **MT104-104**.
- Insert the card carefully into the slots of the Multi-Tasker™ without bending any edges.
- When removing a card, please make sure that the expansion card to which it is attached is also pulled out simultaneously.

1.3 CLEANING

- Clean only the connector area with a dry cloth. Never use strong detergents or solvents, such as alcohol or thinner. Do not use a wet cloth or water to clean the card. Do not clean or touch any component or PCB.

1.4 FCC / CE NOTICE

- This device complies with part 15 of the FCC Rules. Operation is subject to the following two conditions: (1) This device may not cause harmful interference, and (2) this device must accept any interference received, including interference that may cause undesired operation.

- This equipment has been tested and found to comply with the limits for a Class A digital device, pursuant to Part 15 of the FCC Rules. These limits are designed to provide reasonable protection against harmful interference when the equipment is operated in a commercial environment. This equipment generates, uses, and can radiate radio frequency energy and, if not installed and used in accordance with the instruction manual, may cause harmful interference to radio communications. Operation of this equipment in a residential area is likely to cause harmful interference in which case the user will be required to correct the interference at his own expense.
- Any changes or modifications to the unit not expressly approved by ALTINEX, Inc. could void the user's authority to operate the equipment.

ABOUT YOUR MT104-104 2

MT104-104 6-in MT VGA Switcher Expansion Card

The **MT104-104** is a 6-in VGA Switcher Expansion Card designed for use together with the MT104-102 or MT104-105 in a Multi-Tasker™ enclosure. When installed, this card expands the total number of VGA inputs by 6. For example, one **MT104-104** used together with one MT104-102 provides a total of 12 VGA inputs. Two **MT104-104** cards used with the MT104-102 provide a total of 20 VGA inputs. The connection between the MT104-102 and **MT104-104** is made via an internal cable.

Female 15-pin HD (VGA-type) connectors are provided for input and output. If used together with 15-pin HD to 5 BNC adapter cables available from ALTINEX, the **MT104-104** can pass RGBHV format computer video signals as well. Inputs are selected via easy-to-use ASCII commands from a control system or computer connected to the RS-232 port of the Multi-Tasker™ Basic Enclosure.

For convenience and flexibility, the **MT104-104** offers Sync Delay™, which briefly “blanks” the video channel signals while switching between signals, thereby avoiding any visual “glitch.” The **MT104-104** is Plug & Play compatible.

TECHNICAL SPECIFICATIONS 3

FEATURES/ DESCRIPTION	MT104-104
GENERAL	
Inputs	
Input Connector	(6) 15-pin HD Female
Internal Connector	(1) 10-pin IDC
Compatibility	VGA thru QXGA, RGBHV & RGBS

Table 1. **MT104-104** General

MECHANICAL	MT104-104
Enclosure Slots Required	Two
Weight	1.0 lb (0.45 kg)
Connector Panel	Black
T° Operating	10°C-35°C
T° Storage	50°C
Humidity	90% non-condensing
MTBF (calc.)	40,000 hrs

Table 2. **MT104-104** Mechanical

ELECTRICAL	MT104-104		
Input Video Signals			
Analog	1.7Vp-p max		
Impedance	75 Ohms +/-1% (terminated)		
Type	Differential		
Input Sync Signal			
Horizontal, Vertical	TTL (+/-)		
Impedance	10k Ohms		
Output Video Signals			
Analog	1.7V p-p max (terminated)		
Impedance	75 Ohms		
Output Sync Signals			
Horizontal, Vertical	TTL (+/-)		
Impedance	22 Ohms		
Frequency Compatibility			
Horizontal	15-130 kHz		
Vertical	25-180 Hz		
Bandwidth	350 MHz @-3dB		
Power			
Power from MT100-100	+6V	-6V	Power Consumption
MT104-104	110mA	80mA	1.1 watts

Table 3. **MT104-104** Electrical

PRODUCT DESCRIPTION 4

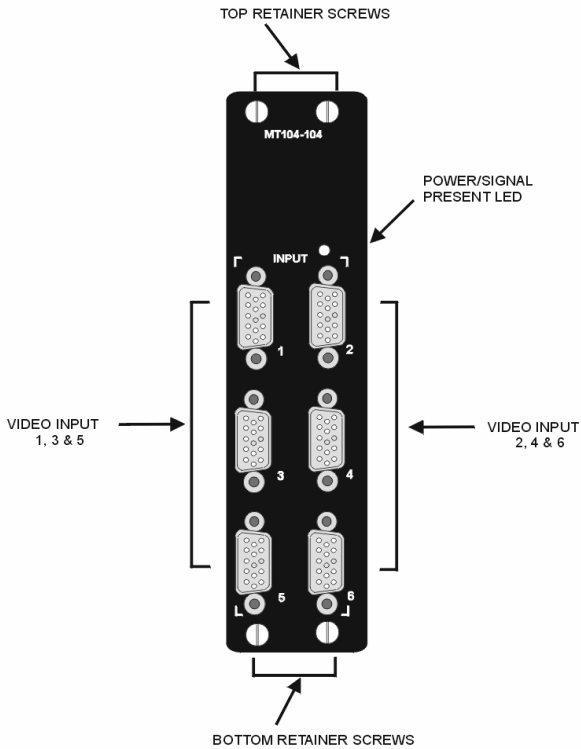

APPLICATION DIAGRAM 5

Application Diagram 1

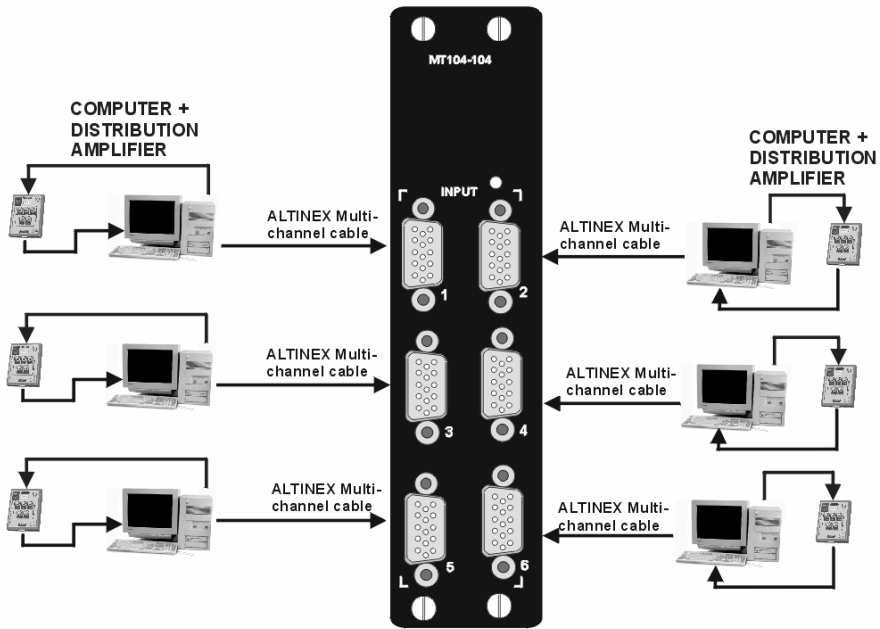

Application Diagram 2: Internal View of the MT104-104

6 IN VGA SW EXPANSION + 350 MHZ + POWER + PNP

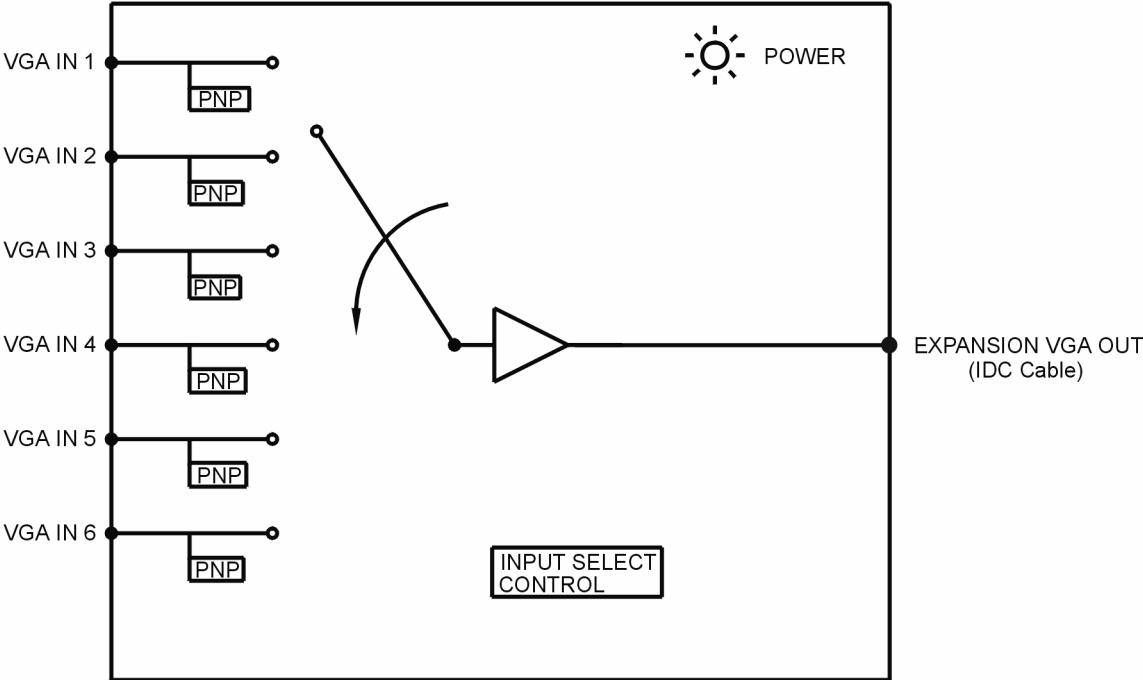

INSTALLING YOUR MT104-104 6

- Step 1.** Locate the VGA card (MT104-102, MT104-105, etc.) to which the internal output cable from the **MT104-104** will be connected. Connect the 10-pin jumper of the MT104-102 to the 10-pin jumper located on the **MT104-104** using a 10-pin IDC cable.
- Step 2.** Slide the (previously connected) MT104-102 and the **MT104-104** into available slots in the Multi-Tasker™ Enclosure. Make sure that the **MT104-104** and the MT104-102 fit into place. Secure the cards to the Multi-Tasker™ by tightening the retainer screws located on the top and bottom of each card.
- Step 3.** Connect an output cable from the video source to the input connector of the **MT104-104**. Connect the output connector of the MT104-102 to the display devices through an input cable.
- Step 4.** Starting from the left, count the slot number of the MT100-100 where the **MT104-104** is plugged into the Enclosure and note that it is for RS-232 control.

OPERATION 7

7.1 RS-232 CONTROL

When used in the Multi-Tasker™ Enclosure, the **MT104-104** has many advanced remote control capabilities, which are accessible through standard RS-232 communication. The actual controlling can be accomplished through a computer control system or any other device capable of sending RS-232 commands.

7.1.1 RS-232 INTERFACE

The RS-232 commands for the **MT104-104** are in a simple ASCII character format.

1. **Square brackets “[]” are part of the command.**
2. **Use uppercase letters for all commands.**
3. **Commands may be executed with or without a space.**

After processing a command, an OK or ER will be returned as feedback if "F" is included at the end of a command string or if the unit ID is zero.

Commands such as [ON], [OFF], and [IO] that end in "S" will be saved into memory. Commands not ending in "S" will still be executed but will not be restored when the system is reset (power off & power on again).

7.2 DESCRIPTION OF COMMANDS

Each command consists of three parts: function, card ID, and unit ID. [Function, Card ID, Unit ID]

Example:

[VERC3U2]

VER = Function

C3 = Card ID

U2 = Unit ID

For function, see a detailed explanation under each command description.

Card ID is an assigned value from 1 to 19 (1 to 8 or 1 to 2 depending on which enclosure is being used), which represents the number of slots. Card ID 0 (C0) is used for the controller (see user's guide for the MT100-100). Changing the position of a card will significantly affect the commands

recorded on software definitions or a third party control system.

Unit ID has a value from 0 to 9. Unit ID 0 should be used for single unit operation. If the Unit ID is set to 0, then each command can be used without Ui (use command [SETU0]; see user's guide for the MT100-100).

Example:

[VERC3]: for unit ID zero
[VERC3Ui]: for unit ID other than zero
[VERC3]: equivalent to [VERC3U0]

1. [VER]

This command receives the software version and card type for the **MT104-104** card.

Command Format: [VERCnUi]

Cn = card ID number (n = # from 1 to 19)
(1-8 for MT100-101 or 1-2 for MT100-102)
Ui = Unit ID (i = # from 0 to 9) (refer to the MT100-100 user's guide for explanation)

Example:

If one **MT104-104** card is in slot #2 of unit 3:

To send command [VERC2U3], the Multi-Tasker™ Enclosure will return feedback as [Ver 125001 VGA-SW C02]

125001 = software version
VGA-SW = card type: **MT104-104**
C02 = Card ID # 2 (slot 2)

2. [C]

This command receives the status of the card.

Command Format: [CnUi]

Cn = card id (n = 1 to 19)
(1-8 for MT100-101 or 1-2 for MT100-102)
Ui = unit id (i = from 0 to 9) (refer to the MT100-100 user's guide for explanation)

Example:

If one **MT104-104** card is in slot #2 of unit 3 with input 1 ON:

To send command [C2U3], the Multi-Tasker™ Enclosure will return feedback as [On1 C02] or [On1 ER03 C02] if there is error number 3 (see error code list).

If there is no card in slot #2 of unit 3, sending the [C2U3] command will not return any feedback.

ERROR CODES

ER01: CPU Error

This error indicates that the CPU is not working properly.

ER02: I²C Communication Error

This means that the communication between the **MT104-104** card and its serial device has failed.

ER03: RS485 Communication Error

This type of error is a communication error between the **MT104-104** card and the controller of the Multi-Tasker™ Enclosure.

3. [ON]

This command enables one input of a single card or a group of cards.

- [ONmCnUiS]: for a single card

This command enables input "m" and disables all other inputs.

Default when plugged in = All inputs are OFF

m = Input number (m = 1 to 6)
Cn = Card ID No. (n = slot # from 1 to 19)
(1-8 for MT100-101 or 1-2 for MT100-102)
Ui = Unit ID number (i = 0 to 9)
S = saves command to memory

Example:

If all of the inputs on the **MT104-104** card are OFF and the card is in slot #5 of unit 3:

- 1) [ON1C5U3]: Turns ON input 1 of the **MT104-104** card.
- 2) [ON3C5U3]: Turns ON input 3 (input 1 is now OFF).

- [ONmGkUiS]: for a group of cards

This command enables input "m" for each card in group "k" of unit "i".

m = card input (m = # from 1-6)
Gk = group number (k = # from 1-9)
Ui = unit number (i = # from 0-9)
S = saves command to memory

Example:

[ON1G1U1]: Turns ON input 1 for each card in group 1 of unit 1.

- **[ON.....P]: sets path**

This command will set the path for the output, but it is not active until the switch command is executed ([SW]). Commands ending in "P" are not executed immediately. The path for outputs on multiple cards or the same card can be loaded.

Command Format: [ONmCnUiP]

m = input number (m = 1 to 6)
Cn = card ID no. (n = slot # from 1 to 19)
(1-8 for MT100-101 or 1-2 for MT100-102)
Ui = unit number (i = # from 0-9)
P = path

Example:

If there are two **MT104-104** cards in slot 6 and 7 of unit 3:

To enable input 1 of card 6 and input 3 of card 7 simultaneously, use the following commands:

```
[ON1C6U3P]
[ON3C7U3P]
[SW]
```

If "F" is included use the [ONmCnUiPF] command or the [ONmCnUiFP] command.

- **[ON.....F]: feedback**

After processing a command, an OK or ER will be returned as feedback if "F" is included at the end of a command string or if the unit ID is zero.

Example:

[ON1C2U3F]: if path is not set
[ON1C2U3PF]: if path is set

4. [OFF]

This command disables one or all inputs of a single card or a group of cards.

- **[OFFmCnUiS]: for a single card**

This command disables input "m" or all inputs.

[OFFC5CnUi]: Turns OFF all inputs of the **MT104-104** card.

m = Input number (m = 1 to 6)
Cn = Card ID number (n = slot # from 1 to 19)
(1-8 for MT100-101 or 1-2 for MT100-102)
Ui = Unit ID number (i = 0 to 9)
S = saves command to memory

Example:

If card 5 of unit 3 has input 1 ON, the following commands can be used to turn OFF the input.

- 1) **[OFF1C5U3]**: Turns OFF input 1 (or all inputs are off).
- 2) **[OFFC5U3]**: All inputs are OFF.

- **[OFFmGkUiS]: for a group of cards**

This command disables input "m" for each card in group "k" of unit "i".

m = card input (m = # from 1-6)
Gk = group number (k = # from 1-9)
Ui = unit number (i = # from 0-9)
S = saves command to memory

Example:

1. [OFF1G1U1]: Turns OFF input 1 for each card in group 1 of unit 1 (all inputs are off).
2. [OFFG1U1]: Turns OFF all inputs for each card in group 1 of unit 1 (all inputs are off).

- **[OFF.....P]: sets path**

This command will set the path for the output, but it is not active until the switch command is executed ([SW]). Commands ending in "P" are not executed immediately. The path for outputs on multiple cards or the same card can be loaded.

Command Format: [OFFmCnUiP]

m = input number (m = 1 to 6)
Cn = card ID no. (n = slot # from 1 to 19)
(1-8 for MT100-101 or 1-2 for MT100-102)
Ui = unit number (i = # from 0-9)
P = path

Example:

If there are two **MT104-104** cards in slot 6 and 7 of unit 3:

To enable input 1 of card 6 and input 3 of card 7 simultaneously, use the following commands:

```
[OFF1C6U3P]
[OFF3C7U3P]
[SW]
```

If "F" is included use the [OFFmCnUiPF] command or the [OFFmCnUiFP] command.

• [OFF.....F]: feedback

After processing a command, an OK or ER will be returned as feedback if "F" is included at the end of a command string or if the unit ID is zero.

Example:

```
[OFF1C2U3F]: if path is not set
[OFF1C2U3PF]: if path is set
```

5. [SW] – Switch

The switch command immediately connects inputs and outputs, which were previously set with the path command on this card and all other cards in the MT100-100.

Example:

```
[ON1C6U3P]
[ON3C7U3P]
[SW]
```

The system will return feedback as OK if the unit ID is zero.

6. [WR]

This command groups multiple cards in the MT100-100 Enclosure. Each unit contains a maximum of nine groups.

Command Format: [WRCn...GkUi]

Cn = card ID No. (n = slot # from 1 to 19)
(1-8 for MT100-101 or 1-2 for MT100-102)
Gk = group number (k = # from 1-9)
Ui = unit number (i = # from 0-9)

Example:

To group card #1, 2, and 3 as group 5 of unit #1, send the [WRC1C2C3G5U1] command. After executing this command, cards 1, 2, and 3 of unit 1 will be grouped together as group 5.

7. [CLR]

This command clears the members for a single group or for all nine groups.

Command Format: [CLRGkUi]

Gk = group number (k = # from 1-9)
Ui = unit number (i = # from 0-9)

Example:

- To clear group #1, send the [CLRG1U1] command. This command clears the members for the specified group only.
- To clear all groups of unit 1, send the [CLRG*U1] command.

8. [G]

This command is used to request group data. With the command, the user can identify which input or output of a particular group is on.

Command Format: [GkUi]

Gk = group number (k = # from 1-9)
Ui = unit number (i = # from 0-9)

Example:

If group 1 has DA Cards with output 1 and 2 on, while group 2 has SW Cards with input 2 on:

- [G1]: will return feedback as [On12G1].
- [G2]: will return feedback as [On2G2].

9. [RD]

This command displays the members in each group.

Command Format: [RDGkUi]

Gk = group number (k = # from 1-9)
Ui = unit number (i = # from 0-9)
member = C1 - C19 (card 1 to 19)
(1-8 for MT100-101 or 1-2 for MT100-102)

Example:

To read member data for group 1 of unit 1, send the [RD] command. The system will return feedback as C1C2C3 G5U1.

7.3. SUMMARY OF COMMANDS

- [VER]: Receives software version

- 2) [C]: Receives status of the card
- 3) [ON]: Turns on one input for a single card or a group of cards
- 4) [OFF]: Turns off one input for a single card or a group of cards
- 5) [SW]: Switch (activates the preset path)
- 6) [WR]: Groups multiple cards
- 7) [CLR]: Clears a single group or multiple groups
- 8) [G]: Requests group data
- 9) [RD]: Displays the members in each group

TROUBLESHOOTING GUIDE 8

We have carefully tested and have found no problems in the supplied **MT104-104**; however, we would like to offer suggestions for the following:

- 8.1 LED IS NOT LIT
- 8.2 LED IS BLINKING RED
- 8.3 NO DISPLAY

8.1 LED IS NOT LIT

A) Cause 1: Card cage is not plugged in.

Solution: Plug card cage in. If the LED lights, the problem is solved. If the LED is still not lit, see Cause 2.

B) Cause 2: Card is not plugged in all the way.

Solution: Push the card in all the way. If the LED is still not lit, see Cause 3.

C) Cause 3: Card cage slot has a problem.

Solution 1: Test the card in other slots of the card cage. If the slot was damaged, the card may work in other slots. If other slots work and the LED lights, the problem is the card cage slot. The card cage may require service. Call ALTINEX at (714) 990-2300. If the other slots do not work and the LED is still not lit, see

Solution 2.

Solution 2: Take any other known good card with an LED and verify that the slot used is good by seeing if the other card's LED lights in that slot. If it lights, then the original card may be the source of the problem. Call ALTINEX at (714) 990-2300.

8.2 LED IS BLINKING RED

If the LED on the card is blinking red, find the error code. For example, if you are using card 5 of unit 1, send the [C5U1] command to see the status and error code. Note that card 5 refers to slot 5.

A) Cause 1: The CPU on the card is not working properly.

- If the CPU is not working, you will receive an ER01 message. The system will return feedback as [On1 ER01 C05] when using card 5 of unit 1.
- ER01 Code: CPU error

Solution 1: Look at the card and verify that there is no damage. If there is no damage, see Solution 2.

Solution 2: Verify that all IC's are seated in their sockets. If the LED is still blinking red, see Solution 3.

Solution 3: Call ALTINEX at (714) 990-2300.

B) Cause 2: The MT104-104 card and its serial device are not communicating.

- If there is no communication between the **MT104-104** card and its serial device, you will receive an ER02 message. The system will return feedback as [On1 ER02 C05] when using card 5 of unit 1.
- ER02 Code: Communication error between the **MT104-104** card and its serial device.

Solution 1: Turn the system OFF and then

ON again. If there is still an error message, see Solution 3.

Solution 2: Call ALTINEX at (714) 990-2300.

C) Cause 3: RS485 communication error

- If there is an RS485 communication error, you will receive an ER03 message. The system will return feedback as **[On1 ER03 C05]** when using card 5 of unit 1.
- ER03 Code: RS485 communication error

Solution 1: Make sure that the card is pushed all the way into the slot. If there is still an ER04 message, see Solution 2.

Solution 2: Turn the system OFF and then ON again. If there is still an error message, see Solution 3.

Solution 3: If there is still a problem, call ALTINEX at (714) 990-2300.

Solution: Make sure that the display is powered. If there is still no display, call ALTINEX at (714) 990-2300.

8.3 NO DISPLAY

A) Cause 1: The source has a problem.

Solution: Check the source and make sure that there is a signal present and all source connections are correct. If the source is working and there is still no display, see Cause 2.

B) Cause 2: The card input is not selected.

Solution: Select the card input. See RS-232 accessible commands in section 7. If no display is present, see Cause 3.

C) Cause 3: Cable connections to the destination are incorrect.

Solution: Make sure that cables are connected properly. Also, make sure that the continuity and wiring are good. If there is still no display present, see Cause 4.

D) Cause 4: The display has a problem.

ALTINEX POLICY

9

9.1 LIMITED WARRANTY

ALTINEX warrants that its products and cables are free from defects in materials under normal use and service. This warranty is limited to repairing at company's factory any part or parts of the product, which upon company's examination shall disclose to be, thus defective. Products considered defective should be returned to company with transportation charges pre-paid within 2 years (90 days for cables) from date of shipment to the purchaser. The warranty is expressly instead of all other warranties expressed or implied. ALTINEX neither assumes nor authorizes any other person to assume for it any other liability in connection with the sale of the products. This warranty shall not apply to any product that shall have been repaired or altered outside of company's factory in any way so as, in its judgment, to affect its stability or reliability, or that has been subject to misuse, negligence or accident.

9.2 RETURN POLICY

It is very important to ALTINEX that you receive the products that you have ordered and that this product fulfills your need. In the unlikely event, that an ALTINEX product needs to be returned please follow the policies below:

ALTINEX will accept product returns for a period of 30 days from authorized ALTINEX dealers. Products must be returned in an unopened package.

If a product has been opened, the restocking fees will apply. For the restocking fee amount, please contact an ALTINEX Sales Representative.

If the product is in your possession for more than 30 days, the restocking fees will apply.

ALTINEX will not accept any returns on cables or custom products.

If your product is in warranty and needs service, contact the ALTINEX Sales Department for an RMA (Return Material Authorization). Products returned without an RMA number may experience a delay in service.

If your product is out of warranty and needs service, contact the ALTINEX Sales Department for an RMA (Return Material Authorization). Products returned without an RMA number may experience a delay in service. The service charges will be quoted to you before the actual repairs are done.

9.3 CONTACT INFORMATION

ALTINEX, INC.

592 Apollo Street
Brea, CA 92821 USA

TEL: 714-990-2300

TOLL FREE: 1-800-ALTINEX

WEB: www.altinex.com

E-MAIL: solutions@altinex.com

FAX: 714-990-3303