



---

MANUAL PART NUMBER: 400-0133-002

**CNK221**

**CABLE-NOOK JR.  
INTERCONNECT BOX  
USER'S GUIDE**

## TABLE OF CONTENTS

---

	Page
PRECAUTIONS / SAFETY WARNINGS .....	2
GENERAL .....	2
INSTALLATION.....	2
CLEANING .....	2
FCC / CE NOTICE.....	2
ABOUT YOUR <b>CNK221</b> .....	3
TECHNICAL SPECIFICATIONS.....	3
<b>CNK221</b> DIMENSIONS .....	4
DIAGRAM 1.....	4
DIAGRAM 2.....	5
APPLICATION DIAGRAM .....	5
DIAGRAM 3.....	5
DIAGRAM 4.....	6
DIAGRAM 5.....	7
INSTALLATION .....	8
OPERATION .....	9
CABLES AND ACCESSORIES.....	9
TROUBLESHOOTING GUIDE .....	9
ALTINEX POLICY.....	10
LIMITED WARRANTY.....	10
RETURN POLICY .....	10
CONTACT INFORMATION .....	10

---

**This manual covers:**

**CNK221** – Cable Nook Jr. Tabletop Interconnect  
Box with Square Bezel

## PRECAUTIONS / SAFETY WARNINGS 1

Please read this manual carefully before using your **CNK221** Tabletop Cable-Nook™ Jr. Interconnect Box. Keep this manual handy for future reference. These safety instructions are to ensure the long life of your **CNK221** and to prevent fire and shock hazard. Please read them carefully and heed all warnings.

### 1.1 GENERAL

- Unauthorized personnel shall not open the unit since there are high-voltage components inside.
- Qualified ALTINEX service personnel, or their authorized representatives must perform all service.

### 1.2 INSTALLATION

- For best results, place the **CNK221** Tabletop Cable-Nook™ Jr. Interconnect Box in a dry area away from dust and moisture.
- To prevent fire or shock, do not expose this unit to rain or moisture. Do not place the **CNK221** Tabletop Cable-Nook™ Jr. Interconnect Box in direct sunlight, near heaters or heat radiating appliances, or near any liquid. Exposure to direct sunlight, smoke, or steam can harm internal components.
- Handle the **CNK221** Tabletop Cable-Nook™ Jr. Interconnect Box carefully. Dropping or jarring can damage internal components.
- Never place fingers inside the openings in the back of the unit. This action could cause serious injury because of the sharp edges inside of the **CNK221**.
- Do not place heavy objects on top of the **CNK221**. Do not use excessive force to push down on the top of the unit.
- We recommend using wall outlets with a Ground Fault Circuit Interrupter (GFCI) for maximum protection.
- Install all cables according to the instructions.

### 1.3 CLEANING

- Surfaces should be cleaned with a dry cloth. Never use strong detergents or solvents, such as alcohol or thinner. Do not use a wet cloth or water to clean the unit.

### 1.4 FCC / CE NOTICE

- This device complies with part 15 of the FCC Rules. Operation is subject to the following two conditions: (1) This device may not cause harmful interference, and (2) this device must accept any interference received, including interference that may cause undesired operation.
- This equipment has been tested and found to comply with the limits for a Class A digital device, pursuant to Part 15 of the FCC Rules. These limits are designed to provide reasonable protection against harmful interference when the equipment is operated in a commercial environment. This equipment generates, uses, and can radiate radio frequency energy and, if not installed and used in accordance with the instruction manual, may cause harmful interference to radio communications. Operation of this equipment in a residential area is likely to cause harmful interference in which case the user will be required to correct the interference at his own expense.
- Any changes or modifications to the unit not expressly approved by ALTINEX, Inc. could void the user's authority to operate the equipment.

## ABOUT YOUR CNK221

2

The **CNK221** is designed for installation into a conference room or boardroom table. The **CNK221** Tabletop Cable-Nook™ Jr. Interconnect Box provides a means of connecting audio, video, and other media sources into a presentation system. It is ideal for use with ALTINEX computer video interfaces or distribution amplifiers.

The **CNK221** Tabletop Cable-Nook™ Jr. Interconnect Box provides a simple yet effective way of storing and hiding cables eliminating the obstruction. The cables can remain connected to a presentation system, enabling the user to connect them to different media sources needed for a presentation. After the presentation, the cables may be returned to the **CNK221** for safe storage.

The **CNK221** Tabletop Cable-Nook™ Jr. Interconnect Box is designed for use with tables ranging from one to three inches thick. It offers an adjustable bracket shelf to secure the cable ends. The bracket shelf can be adjusted to fit a variety of cable sizes. The height of the bracket shelf can also be adjusted for different depths.

There is also an internal AC power connection on the shelf.

The **CNK221** comes in a standard matte black color. The top of the unit can be finished to match the table. This is available on a custom per order basis at an additional charge.

There is an optional circular bezel available with the Cable Nook Jr. Please refer to page 6 of the manual for additional information.

## TECHNICAL SPECIFICATIONS

3

FEATURES/DESCRIPTION	CNK221 (custom)
<b>MECHANICAL</b>	
Width (inches)	4.08in (104mm)
Height (inches) cover opened	7.40in (188mm)
Height (inches) cover closed	4.79in (122mm)
Finish	Matte Black
T° Operating	10°C-35°C
T° Maximum	50°C
Humidity	90% non-condensing

Table 1. **CNK221** Mechanical

ELECTRICAL	CNK221 (custom)
<b>Power</b>	
Power Rating (pass-through IEC connector)	90-140 VAC

Table 2. **CNK221** Electrical

**DESCRIPTION OF CNK221**

**4**

Diagram 1A - 1D: Dimensions

**SIDE VIEW**  
(open position)

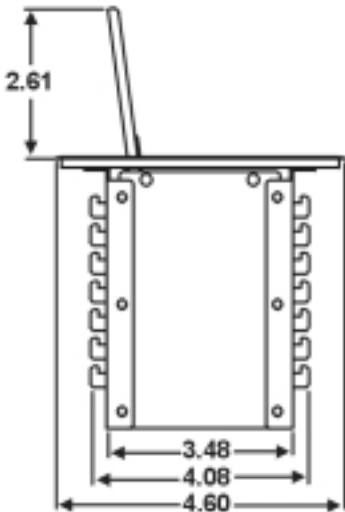

Diagram 1A

**TOP VIEW**  
(cover removed)

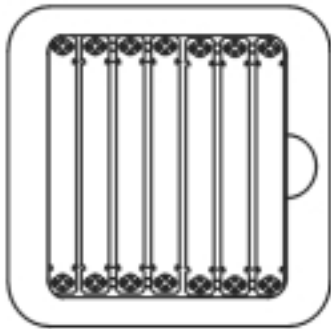

Diagram 1B

**TOP VIEW**  
(closed position)

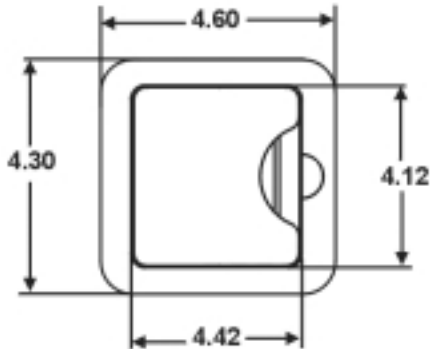

Diagram 1C

**SIDE VIEW**  
(closed position)

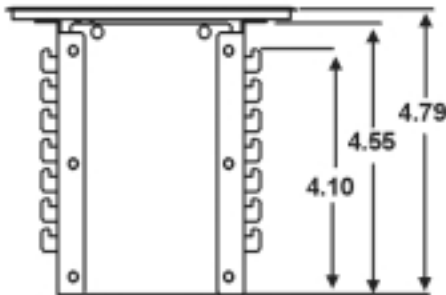
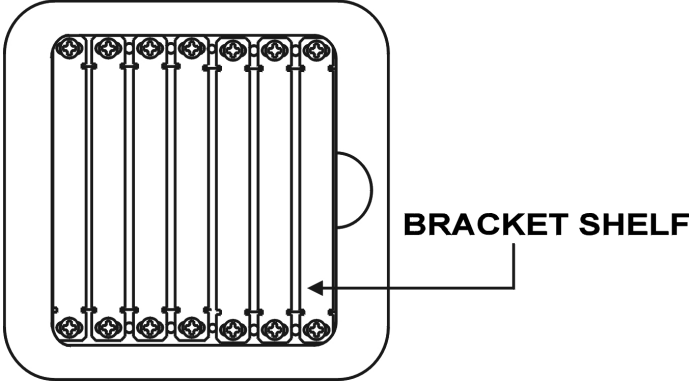

Diagram 1D

Diagram 2

## TOP VIEW (cover removed)



### APPLICATION DIAGRAM 5

Diagram 3

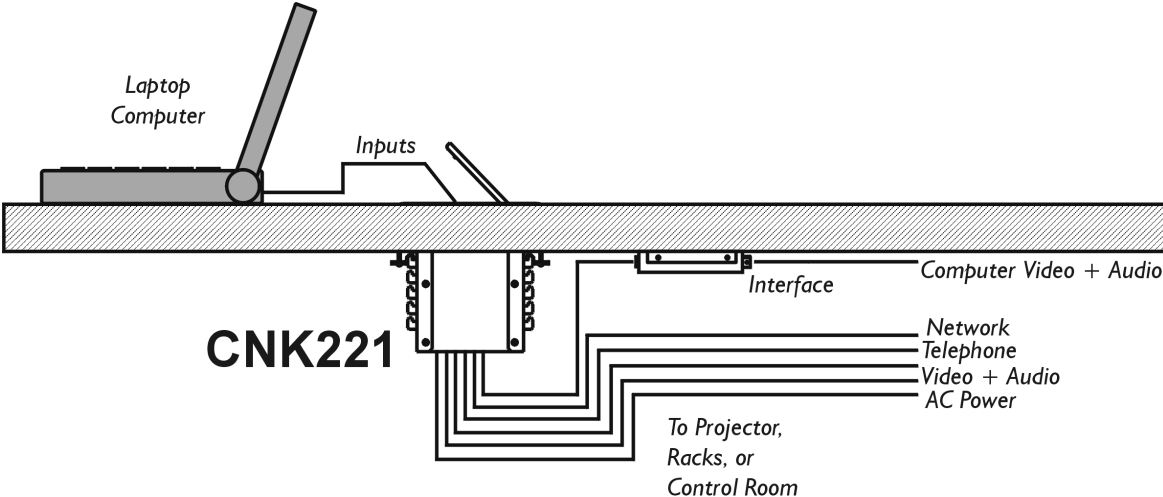
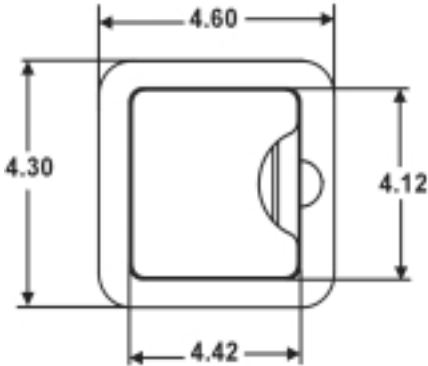

Diagram 4: Bezels

CNK221



CABLE-NOOK JR.

Optional

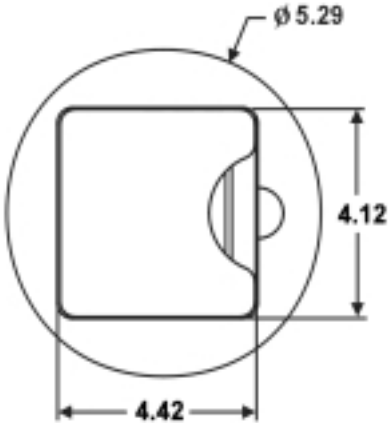

CABLE-NOOK JR. WITH CIRCULAR BEZEL

**Diagram 5: Table Cutout Requirements**

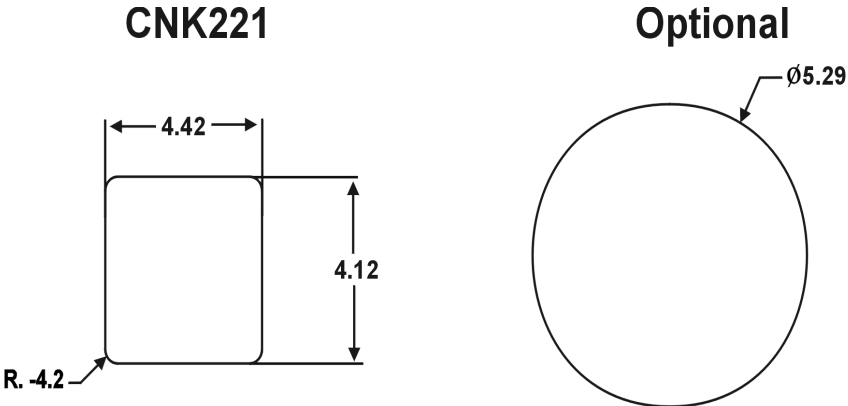

**NOTE:** Specifications subject to change without notice. Always confirm measurements before cutting to ensure that specifications have not changed. Always make sure to orient cutout in direction necessary for proper operation of the installed unit.



## INSTALLING YOUR CNK221

6

**Step 1.** Cut an opening into the table's surface. Refer to diagram 5 on page 7 of this manual for table cutout requirements. Note: The table can be 3 inches or thinner in thickness. Always confirm dimensions before cutting to ensure that specifications have not changed.

**Step 2.** Insert the **CNK221** unit into the table.

**Step 3.** Place the support mount brackets under the table and place them between the support mount grooves on the side of the **CNK221** unit. Attach the brackets to the groove at the desired height and secure them to the bottom of the table using the 6-32 screw. There are two support brackets, one for each side of the unit. (See figure 1). The **CNK221** remains flush or at exactly the same level as the tabletop when not in use.

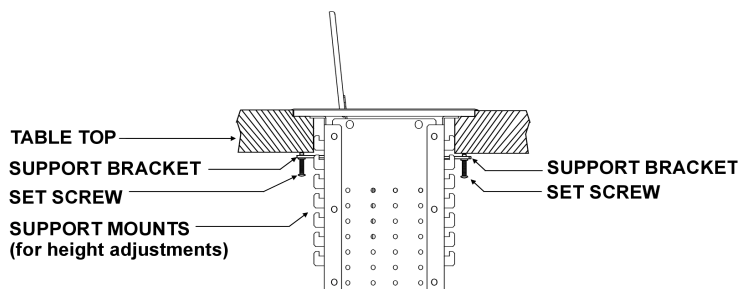

**Figure 1: Attachment of the CNK unit to the table using support brackets and set screws.**

**Step 3.** Place the bracket shelf inside of the **CNK221** unit housing. The height of the bracket shelf can be adjusted for different depths. (See figure 2)

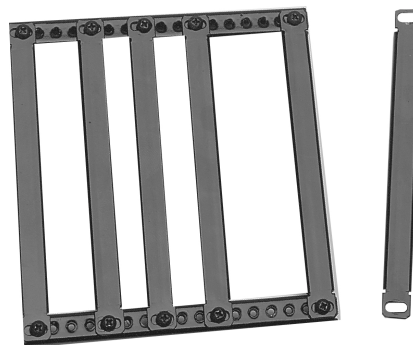

**Figure 2: Bracket Shelf**

**Step 4.** Secure the cables using the provided cable clamps. (See figure 3)

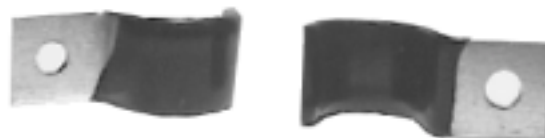

**Figure 3: Cable Clamps**

**Step 5.** Connect the appropriate cables with the correct input connectors of the media sources (video, audio, etc.) being used. The **CNK221** unit may be custom modified to fit your connector needs. See catalog for custom modifications.

## OPERATION 7

There are no adjustments necessary to operate the **CNK221**, the unit will operate successfully as long as cables are attached properly and other technical specifications are followed.

## CABLES AND ACCESSORIES 8

Model No.	Description
<b>INSERT PLATES FOR CABLE NOOK</b>	
<b>CNK-IP-101</b>	Insert plate w/ 6 empty ports for snap-in connectors
<b>CNK-IP-102</b>	Insert plate w/ 2 empty ports for D-Sub connectors
<b>SHELVES FOR CABLE NOOK</b>	
<b>CNK-OS-201</b>	Optional shelf w/ short brackets & 6 empty snap-in ports
<b>CNK-OS-202</b>	Optional shelf w/ short brackets & 6 loaded snap-in connectors

**Note:** The items above must be ordered in quantities of 5 pieces.

Model No.	Description
<b>MULTI - MEDIA LABELS</b>	
<b>MS8301LB</b>	Input/ Output Labels; black w/ white text
<b>VGA MALE TO MALE (HD-15) HIGH RESOLUTION CABLE</b>	
<b>CB37xxMR</b>	xx = available length of 3ft, 6ft, 15ft, 25ft, 50ft, 75ft, 100ft, 150ft
<b>VGA MALE TO FEMALE (HD-15) HIGH RESOLUTION CABLE</b>	
<b>CB39xxMR</b>	xx = available length of 3ft, 6ft, 15ft, 25ft, 50ft, 75ft, 100ft, 150ft, 200ft, 250ft
<b>POWER CABLES</b>	
<b>PC5301US</b>	AC Power Cable, 6 ft. – United States (M) to IEC (F)
<b>PC5302UK</b>	AC Power Cable, 6 ft. – United Kingdom (M) to IEC (F)
<b>PC5303AU</b>	AC Power Cable, 6 ft. – Australian (M) to IEC (F)
<b>PC5304GR</b>	AC Power Cable, 6 ft. – German (M) to IEC (F)

## TROUBLESHOOTING GUIDE 9

The **CNK221** supplied unit was carefully tested and no problems were detected; however, we would like to offer these suggestions.

- Please make sure that the highest quality video, audio, and any other cables or connectors are used.
- Make sure that cables have not been damaged or pinched. If there is damage to the cables, then do not use the **CNK221** unit. Immediately contact the ALTINEX Customer Service Department to have the unit repaired.
- There are no adjustments necessary to operate the **CNK221**, the unit will operate successfully as long as cables are attached properly and other technical specifications are followed.

## ALTINEX POLICY 10

### 10.1 LIMITED WARRANTY

ALTINEX warrants that its products and cables are free from defects in materials under normal use and service. This warranty is limited to repairing at company's factory any part or parts of the product, which upon company's examination shall disclose to be, thus defective. Products considered defective should be returned to company with transportation charges pre-paid within 2 years (90 days for cables) from date of shipment to the purchaser. The warranty is expressly instead of all other warranties expressed or implied. ALTINEX neither assumes nor authorizes any other person to assume for it any other liability in connection with the sale of the products. This warranty shall not apply to any product that shall have been repaired or altered outside of company's factory in any way so as, in its judgment, to affect its stability or reliability, or that has been subject to misuse, negligence, or accident.

### 10.2 RETURN POLICY

It is very important to ALTINEX that you receive the products that you have ordered and that this product meets your expectations. In the unlikely event, that an ALTINEX product needs to be returned please follow the policy below:

ALTINEX will accept product returns for a period of 30 days from authorized ALTINEX dealers. Products must be returned in an unopened package.

If a product has been opened, the restocking fees will apply. For the restocking fee amount, please contact an ALTINEX Sales Representative.

If the product is in your possession for more than 30 days, the restocking fees will apply.

ALTINEX will not accept any returns on cables or custom products.

If your product is in warranty and needs service, contact the ALTINEX Sales Department for an RMA (Return Material Authorization). Products returned without an RMA number may experience a delay in service.

If your product is out of warranty and needs service, contact the ALTINEX Sales Department for an RMA (Return Material Authorization). Products returned without an RMA number may experience a delay in service. The service charges will be quoted to you before the actual repairs are done.

### 10.3 CONTACT INFORMATION

#### ALTINEX, INC.

592 Apollo Street  
Brea, CA 92821 USA

TEL: 714-990-2300

TOLL FREE: 1-800-ALTINEX

WEB: [www.altinex.com](http://www.altinex.com)

E-MAIL: [solutions@altinex.com](mailto:solutions@altinex.com)

FAX: 714-990-3303