

MULTIMIX 12 FX

MULTIMIX 12 FXD

MULTIMIX 16 FXD

Reference Manual

ALESIS

Table Of Contents

Introduction	5
Welcome!.....	5
About the Multimix	6
Multimix Key Features.....	6
How to Use This Manual	8
A Few Words for Beginners	9
Important Safety Instructions	11
Important Safety Instructions (English)	11
Safety symbols used in this product.....	11
Please follow these precautions when using this product.....	11
Instructions de Sécurité Importantes (French)	13
Symboles utilisés dans ce produit.....	13
Veuillez suivre ces précautions lors de l'utilisation de l'appareil:.....	13
Lesen Sie bitte die folgende Sicherheitshinweise (German)	15
Sicherheit Symbole verwendet in diesem Produkt.....	15
Folgen Sie bitte diesen Vorkkehrungen, wenn dieses Produkt verwendet wird:.....	15
CE Declaration Of Conformity	17
FCC Compliance Statement	17
Chapter 1: Getting Started	19
Hooking up the Multimix	19
Using Proper Cables	19
Setting Levels	20
Chapter Two: A Tour of the MultiMix	21
Patchbay	21
Mic Inputs (Channels 1 – 4).....	21
Line Inputs (Channels 1 – 4).....	21
Line Inputs (Channels 5 – 12).....	22
Digital Output Jack.....	22
PHONE Jack.....	22
AUX RETURNS.....	22
AUX SENDS.....	22
ALT 3/4 OUT.....	22
2-TRACK.....	23
MAIN MIX OUT.....	23
CTRL RM OUT.....	23
Channel Strips	23
Fader.....	23
MUTE / Alt 3/4.....	23
PFL / SOLO.....	23
PAN or BAL.....	24
Aux.....	24
EQ.....	24

Table Of Contents

Master Section	25
Main Mix Fader.....	25
Alt 3/4 Fader.....	25
2TK To Mix.....	25
Alt 3/4 To Mix.....	25
Solo Mode.....	25
HDPH / CTRL RM.....	26
MIX Switch.....	26
ALT 3/4 Switch.....	26
2TK Switch.....	26
Aux Ret A Level.....	26
Effects / Aux Ret B level	26
LED Meters.....	27
POWER Indicator	27
+48V Indicator	27
Rear of the Mixer	27
Power Input.....	27
Power Supply Unit.....	27
Power On.....	27
Phantom On.....	28
Chapter Three: Digital Effects Processor	29
Effects Section Components	29
Program Selection Knob	29
LED Display.....	29
CLIP Indicator.....	29
SIG Indicator	29
Effect Descriptions	29
HALL	29
ROOM	29
PLATE.....	29
CHAMBER.....	29
CHORUS.....	30
FLANGE.....	30
DELAY	30
PITCH.....	30
MULTI & MULTI II.....	30
Chapter Four: Applications	31
Simple Recording Setup.....	31
Simple Live Setup.....	31
Using Additional External Audio Sources.....	31
Importing Music Into Your Computer.....	32
Chapter Five: Troubleshooting	33
Chapter Six: Specifications	37
Chapter Seven: Block Diagram	39

Glossary 41

Warranty/Contact Alesis 43

 Alesis Limited Warranty..... 43

 Alesis Contact Information..... 44

Table Of Contents

Introduction

Welcome!

Thank you for making the Alesis Multimix a part of your studio. Since 1984, we've been designing and building creative tools for the audio community. We believe in our products, because we've heard the results that creative people like you have achieved with them. One of Alesis' goals is to make high-quality studio equipment available to everyone, and this Reference Manual is an important part of that. After all, there's no point in making equipment with all kinds of capabilities if no one explains how to use them. So, we try to write our manuals as carefully as we build our products.

The goal of this manual is to get you the information you need as quickly as possible, with a minimum of hassle. We hope we've achieved that. If not, please drop us an email and give us your suggestions on how we could improve future editions of this manual.

We hope your investment will bring you many years of creative enjoyment and help you achieve your musical goals.

Sincerely,
The people of Alesis

For more effective service and product update notices, please register your MultiMix mixer online at:

<http://www.alesis.com/support/warranty.htm>

About the Multimix

The Multimix consoles are a versatile series of mixers designed to perform well in the live and home studio realm. They are the latest in the large family of Alesis audio mixers. We've come a long way since introducing our first mixing console in 1989. Since that time audio technology has grown in leaps and bounds, pushing up quality and driving down prices. Only a few years ago, you wouldn't have been able to buy a mixer this powerful for such an affordable price. Just take a look at the key features listed below, and you'll see that you have just made an incredible addition to your home studio or live setup.

The Multimix consoles give you just about everything you need to create polished, professional-sounding mixes. When designing this unit, our goal was to give you as much control over your mixes as possible without requiring a wealth of extra equipment. That's why we added tools like the digital effects processor, the mic preamps and the digital out. And with a multitude of ways in which to connect other equipment and instruments, the Multimix offers endless possibilities.

Multimix Key Features

- **Three Models: Multimix-12FX and Multimix-12FXD** (4 microphone/line inputs with up to 50dB of preamp gain), **Multimix-16FXD** (8 microphone/line inputs with up to 50dB of preamp gain)
- **4 stereo inputs** – great for line-level instruments.
- **Internal digital effects processor with 100 preset effects and an easy-to-read display** – includes a variety of reverbs, delays, choruses, flanges, a pitch transposer and multiple combinations of these.
- **3-band EQ per channel** – a potent tool for sonically shaping each channel to get that perfect mix.
- **1 pre/post-fader aux send per channel (switchable)** – gives you control over the level of the pre- or post-fader signal being routed to an external device.
- **1 post-fader aux send/effects send per channel** – a control for the signal being routed to another external device or to the onboard effects processor.
- **PFL/Solo in place functionality per channel** – isolates a channel with a single push of a button.
- **Mute/Alt 3/4 assign per channel** – lets you mute a channel and, at the same time, route its signal to the mixer's ALT 3/4 output—a separate stereo bus.
- **Independent Main Mix and Alt 3/4 levels** – permits you to separately command the levels of the MultiMix's two stereo buses

- **44.1 kHz Digital out** – Allows you to send a crystal clean digital stereo signal directly to a DAT, DVD or other recording device that can accept an S/PDIF signal. (Multimix-12FXD and Multimix-16FXD only)
- **Control room output level** – provides control over the separate control room output
- **2-track send and return** – lets you mix your audio to tape or other media and to add a tape deck or CD player to the mix

How to Use This Manual

This manual is divided into the following sections describing the various functions and applications for the Multimix consoles. While it's a good idea to read through the entire manual once carefully, those having general knowledge about mixing should use the table of contents to look up specific functions.

Chapter 1: Getting Started shows you how to include the Multimix in your audio setup for recording and live applications. We've included a hookup diagram, guidelines for which cables to use and the vital steps you must take to set levels properly.

Chapter 2: A Tour of the MultiMix describes the Multimix piece by piece. This chapter also features diagrams of the mixer to help you find each component as you read about it.

Chapter 3: Digital Effects Processor explains the effects provided by the on-board digital effects processor. If you want to know what a certain effect will do to your sound before you select it, this is where you should look.

Chapter 4: Applications outlines a number of scenarios in which you can use the Multimix, including some tips on what goes where when you're hooking everything up.

Chapter 5: Troubleshooting can give you a hand if you're experiencing problems with your mixer. You'll find that most issues can be resolved simply and quickly with the push of a button.

Chapter 6: Specifications and Chapter 7: Block Diagrams are full of technical information for the more techie users.

And at the end of this manual you'll see a glossary of common mixing-related terms and a page about the Multimix's warranty.

Helpful tips and advice are highlighted in a shaded box like this.



When something important appears in the manual, an exclamation mark (like the one shown at left) will appear with some explanatory text. This symbol indicates that this information is vital when operating the MultiMix consoles.

A Few Words for Beginners

We realize that some of you who have purchased the Multimix are fairly new to the art of mixing, and we've written this manual with that in mind. We designed the Multimix to be both powerful and easy enough to use that even a beginner can quickly pick up the basics.

Many mixer manuals—and manuals for just about any electronic instrument for that matter—are full of complicated terminology and incomplete instructions that presume a lot of experience on the part of the reader. We try to avoid that with this manual. True enough, you will find all the technical lingo and specifications you can handle in here, but we do our best to make this accessible to you.

Beginners will find several elements of this manual especially useful. Keep your eye out for the tips found in the gray boxes on the right side of the page. Be sure to check out the hookup diagrams on page 19, which will give you some ideas on how to fit the mixer into your audio setup after you've taken a tour of the mixer in Chapter 2. And if you come across any terms that you haven't seen before, the glossary probably can help you out.

One of the most important things you'll do before you begin a mixing session is to set the levels. Be sure to refer to the instructions on page 20.

Important Safety Instructions

Important Safety Instructions (English)

Safety symbols used in this product



This symbol alerts the user that there are important operating and maintenance instructions in the literature accompanying this unit.



This symbol warns the user of uninsulated voltage within the unit that can cause dangerous electric shocks.



This symbol warns the user that output connectors contain voltages that can cause dangerous electrical shock.

Please follow these precautions when using this product:



1. Read these instructions.
2. Keep these instructions.
3. Heed all warnings.
4. Follow all instructions.
5. Do not use this apparatus near water.
6. Clean only with a damp cloth. Do not spray any liquid cleaner onto the faceplate, as this may damage the front panel controls or cause a dangerous condition.
7. Install in accordance with the manufacturer's instructions.
8. Do not install near any heat sources such as radiators, heat registers, stoves, or other apparatus (including amplifiers) that produce heat.
9. Do not defeat the safety purpose of the polarized or grounding-type plug. A polarized plug has two blades with one wider than the other. A grounding-type plug has two blades and a third grounding prong. The wide blade or the third prong is provided for your safety. When the provided plug does not fit into your outlet, consult an electrician for replacement of the obsolete outlet.
10. Protect the power cord from being walked on or pinched, particularly at plugs, convenience receptacles, and the point where they exit from the apparatus.
11. Use only attachments or accessories specified by the manufacturer.

Continued next page



12. Use only with a cart, stand, bracket, or table designed for use with professional audio or music equipment. In any installation, make sure that injury or damage will not result from cables pulling on the apparatus and its mounting. If a cart is used, use caution when moving the cart/apparatus combination to avoid injury from tip-over.



13. Unplug this apparatus during lightning storms or when unused for long periods of time.

14. Refer all servicing to qualified service personnel. Servicing is required when the apparatus has been damaged in any way, such as when the power-supply cord or plug is damaged, liquid has been spilled or objects have fallen into the apparatus, the apparatus has been exposed to rain or moisture, does not operate normally, or has been dropped.

15. This unit produces heat when operated normally. Operate in a well-ventilated area with at least six inches of clearance from peripheral equipment.

16. This product, in combination with an amplifier and headphones or speakers, may be capable of producing sound levels that could cause permanent hearing loss. Do not operate for a long period of time at a high volume level or at a level that is uncomfortable. If you experience any hearing loss or ringing in the ears, you should consult an audiologist.

17. Do not expose the apparatus to dripping or splashing. Do not place objects filled with liquids (flower vases, soft drink cans, coffee cups) on the apparatus.

18. **WARNING:** To reduce the risk of fire or electric shock, do not expose this apparatus to rain or moisture.

Instructions de Sécurité Importantes (French)

Symboles utilisés dans ce produit



Ce symbole alerte l'utilisateur qu'il existe des instructions de fonctionnement et de maintenance dans la documentation jointe avec ce produit.



Ce symbole avertit l'utilisateur de la présence d'une tension non isolée à l'intérieur de l'appareil pouvant engendrer des chocs électriques.



Ce symbole prévient l'utilisateur de la présence de tensions sur les raccords de sorties, représentant un risque d'électrocution.

Veillez suivre ces précautions lors de l'utilisation de l'appareil:



1. Lisez ces instructions.
2. Gardez ces instructions.
3. Tenez compte de tous les avertissements.
4. Suivez toutes les instructions.
5. N'utilisez pas cet appareil à proximité de l'eau.
6. Ne nettoyez qu'avec un chiffon humide. Il est potentiellement dangereux d'utiliser des pulvérisateurs ou nettoyeurs liquides sur cet appareil.
7. Installez selon les recommandations du constructeur.
8. Ne pas installer à proximité de sources de chaleur comme radiateurs, cuisinière ou autres appareils (dont les amplificateurs) produisant de la chaleur.
9. Ne pas enlever la prise de terre du cordon secteur. Une prise murale avec terre deux broches et une troisième reliée à la terre. Cette dernière est présente pour votre sécurité. Si le cordon secteur ne rentre pas dans la prise de courant, demandez à un électricien qualifié de remplacer la prise.
10. Évitez de marcher sur le cordon secteur ou de le pincer, en particulier au niveau de la prise, et aux endroits où se trouve l'appareil.
11. N'utilisez que des accessoires spécifiés par le constructeur.

Suite de la page suivante



12. N'utilisez qu'avec un stand, ou table conçus pour l'utilisation d'audio professionnel ou instruments de musique. Dans toute installation, veillez de ne rien endommager à cause de câbles qui tirent sur des appareils et leur support.



13. Débranchez l'appareil lors d'un orage ou lorsqu'il n'est pas utilisé pendant longtemps.

14. Faites réparer par un personnel qualifié. Une réparation est nécessaire lorsque l'appareil a été endommagé de quelque sorte que ce soit, par exemple lorsque le cordon secteur ou la prise sont endommagés, si du liquide a coulé ou des objets se sont introduits dans l'appareil, si celui-ci a été exposé à la pluie ou à l'humidité, ne fonctionne pas normalement ou est tombé.

15. Puisque son fonctionnement normale génère de la chaleur, placez cet appareil au moins 15cm. des équipements périphériques et assurez que l'emplacement permet la circulation de l'air.

16. Ce produit, utilisé avec un amplificateur et un casque ou des enceintes, est capable de produire des niveaux sonores pouvant engendrer une perte permanente de l'ouïe. Ne l'utilisez pas pendant longtemps à un niveau sonore élevé ou à un niveau non confortable. Si vous remarquez une perte de l'ouïe ou un bourdonnement dans les oreilles, consultez un spécialiste.

17. N'exposez pas l'appareil à l'égoutture ou à l'éclaboussement. Ne placez pas les objets remplis de liquides (vases à fleur, boîtes de boisson non alcoolique, tasses de café) sur l'appareil.

18. AVERTISSEMENT: Pour réduire le risque du feu ou de décharge électrique, n'exposez pas cet appareil à la pluie ou à l'humidité.

Lesen Sie bitte die folgende Sicherheitshinweise (German)

Sicherheit Symbole verwendet in diesem Produkt



Dieses Symbol alarmiert den Benutzer, daß es wichtige Funktionen und Wartung Anweisungen in der Literatur gibt, die diese Maßeinheit begleitet.



Dieses Symbol warnt den Benutzer der nicht isolierten Spannung innerhalb der Maßeinheit, die gefährliche elektrische Schläge verursachen kann.



Dieses Symbol warnt den Benutzer, dem Ausgabestecker Spannungen enthalten, die gefährlichen elektrischen Schlag verursachen können.

Folgen Sie bitte diesen Vorkehrungen, wenn dieses Produkt verwendet wird:



1. Lesen Sie die Hinweise.
2. Halten Sie sich an die Anleitung.
3. Beachten Sie alle Warnungen.
4. Beachten Sie alle Hinweise.
5. Bringen Sie das Gerät nie mit Wasser in Berührung.
6. Verwenden Sie zur Reinigung nur ein weiches Tuch. Verwenden Sie keine flüssigen Reinigungsmittel. Dies kann gefährliche Folgen haben.
7. Halten Sie sich beim Aufbau des Gerätes an die Angaben des Herstellers.
8. Stellen Sie das Gerät nicht in der Nähe von Heizkörpern, Heizungsklappen oder anderen Wärmequellen (einschließlich Verstärkern) auf.
9. Verfehlen Sie nicht den Zweck des grounding Terminals auf dem Netzstecker. Dieses Terminal wird für Ihre Sicherheit zur Verfügung gestellt.
10. Verlegen Sie das Netzkabel des Gerätes niemals so, daß man darüber stolpern kann oder daß es gequetscht wird.
11. Benutzen Sie nur das vom Hersteller empfohlene Zubehör.

Fortsetzung auf nächster Seite



12. Verwenden Sie ausschließlich Wagen, Ständer, oder Tische, die speziell für professionelle Audio- und Musikinstrumente geeignet sind. Achten Sie immer darauf, daß die jeweiligen Geräte sicher installiert sind, um Schäden und Verletzungen zu vermeiden. Wenn Sie einen Rollwagen benutzen, achten Sie darauf, das dieser nicht umkippt, um Verletzungen auszuschließen.

13. Ziehen Sie während eines Gewitters oder wenn Sie das Gerät über einen längeren Zeitraum nicht benutzen den Netzstecker aus der Steckdose.



14. Die Wartung sollte nur durch qualifiziertes Fachpersonal erfolgen. Die Wartung wird notwendig, wenn das Gerät beschädigt wurde oder aber das Stromkabel oder der Stecker, Gegenstände oder Flüssigkeit in das Gerät gelangt sind, das Gerät dem Regen oder Feuchtigkeit ausgesetzt war und deshalb nicht mehr normal arbeitet oder heruntergefallen ist.

15. Dieses Gerät produziert auch im normalen Betrieb Wärme. Achten Sie deshalb auf ausreichende Lüftung mit mindestens 15 cm Abstand von anderen Geräten.

16. Dieses Produkt kann in Verbindung mit einem Verstärker und Kopfhörern oder Lautsprechern Lautstärkepegel erzeugen, die anhaltende Gehörschäden verursachen. Betreiben Sie es nicht über längere Zeit mit hoher Lautstärke oder einem Pegel, der Ihnen unangenehm ist. Wenn Sie ein Nachlassen des Gehörs oder ein Klingeln in den Ohren feststellen, sollten Sie einen Ohrenarzt aufsuchen.

17. Setzen Sie den Apparat nicht Bratenfett oder dem Spritzen aus. Platzieren Sie die Nachrichten, die mit Flüssigkeiten (gefüllt werden Blumenvasen, Getränkedosen, Kaffeetassen) nicht auf den Apparat.

18. **WARNING:** um die Gefahr des Feuers oder des elektrischen Schlages zu verringern, setzen Sie diesen Apparat nicht Regen oder Feuchtigkeit aus.

CE Declaration Of Conformity

See our Web site at:

<http://www.alesis.com>

FCC Compliance Statement

This device complies with Part 15 of the FCC rules. Operation is subject to the following two conditions: (1) This device may not cause harmful interference and (2) this device must accept any interference received, including interference that may cause undesired operation.

NOTE: This equipment has been tested and found to comply with the limits for a Class B digital device, pursuant to Part 15 of the FCC Rules. These limits are designed to provide reasonable protection against harmful interference in a residential installation. This equipment generates, uses and can radiate radio frequency energy and, if not installed and used in accordance with the instructions, may cause harmful interference to radio communications. However, there is no guarantee that interference will not occur in a particular installation. If this equipment does cause harmful interference to radio or television reception, which can be determined by turning the equipment off and on, the user is encouraged to try to correct the interference by one or more of the following measures:

- Reorient or relocate the receiving antenna.
- Increase the separation between the equipment and receiver.
- Connect the equipment into an outlet on a circuit different from that to which the receiver is connected.
- Consult the dealer or an experienced radio/TV technician for help.

1 Getting Started

Hooking up the Multimix

This diagram will help you get the Multimix hooked up and ready to go. The equipment you use depends on personal preference and on whether you're performing live or recording. For example, you'll see below that the MAIN MIX OUT can be routed to a recording device for recording, or to a PA system for live performance.

Be sure to follow the guidelines for which cables to use (further down this page) and the procedure for setting levels (on the next page) before you begin mixing.

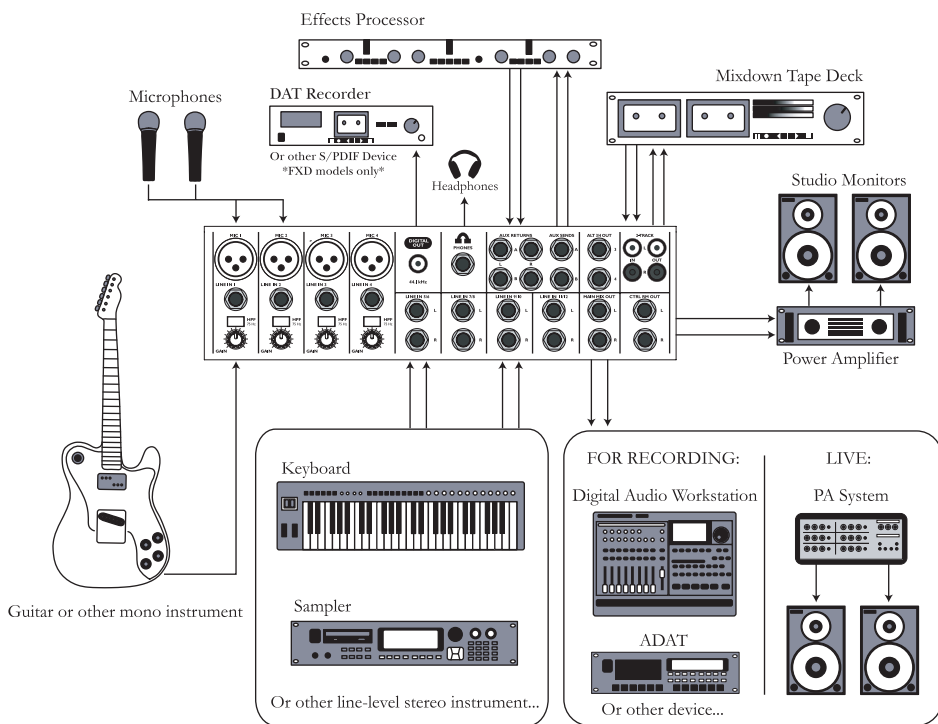

Using Proper Cables

When connecting instruments and other equipment to the MultiMix, it's important that you use the appropriate types of cables. Here are some simple but important guidelines:

- For the mic inputs, use XLR cables.
- For the line inputs and all other 1/4" connections, use 1/4" mono TRS cables.
- And use stereo RCA cables for the 2-track in and out.

- For the S/PDIF Digital out, we suggest that you use a coaxial cable that is specifically designed for S/PDIF applications. These cables are better suited for high frequency (digital) signals and are unbalanced, shielded coaxial cables with shielded RCA connectors on each end. Better to get the high quality S/PDIF cables and save yourself some unnecessary grief.

Setting Levels

Before you can begin mixing different audio sources with your MultiMix, you must set the level for each channel you're using. This helps to prevent distortion and clipping. Here's how:

1. Slide the channel fader to unity gain (0).
2. Turn the AUX SEND and GAIN controls all the way down, and turn the EQ knobs to the center detent (you'll feel a click).
3. Connect the source of the signal to the channel's input.
4. Press the PFL / SOLO switch on the channel.
5. Make sure the SOLO MODE switch in the master section is set to SOLO.
6. Play the instrument at a normal level and watch the LED meters in the master section.
7. Adjust the channel's gain until the LED meters remain at or very close to 0 and do not exceed +6dB.
8. If you need to apply EQ, do so and check the meter again.

2 A Tour of the MultiMix

In this chapter, you'll learn all about the MultiMix's components (except for the digital effects processor, which is explained in the next chapter). Please refer to the diagrams as you read each section to see which components we're talking about.

Patchbay

At the rear portion of the top of the MultiMix, you'll find the patchbay. This is where you plug in instruments, signal processors, multitrack recorders and other devices. Whatever you need to connect to the mixer, this is where it's done. In the following paragraphs, we tell you all about the inputs, outputs, switches and knobs you see in this section of the mixer.

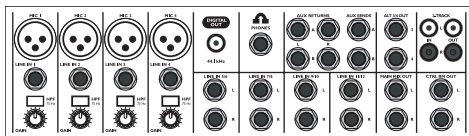

Patchbay

Mic Inputs (Channels 1 – 4)

The MultiMix uses standard XLR-type mic inputs. These provide +48V phantom power that you can turn on and off with the Phantom On switch located on the rear of the mixer. You probably will have to turn on the phantom power when you're using most condenser mics, as these usually require the extra voltage (unless the mic has its own power source, such as a battery). Dynamic and ribbon mics don't require phantom power and are unaffected when the power is on.

These high-quality mic inputs also feature up to 50dB of preamp gain that you can adjust with the Gain knob.

Another useful feature of these mic inputs is a high-pass filter (HPF) that can be turned on and off with the HPF switch. When you activate this switch, all frequencies below 75Hz are cut from the signal. This is useful for mic or line signals that don't have much bottom end, such as vocals, snares, cymbals and electric guitar. You'll want to leave this inactivated for instruments like basses and kick drums.

Line Inputs (Channels 1 – 4)

The line inputs, marked LINE IN, are balanced 1/4" jacks that offer the same 50dB of preamp gain and the high-pass filter provided by the mic inputs (however, phantom power does not apply to line inputs). These inputs accept line-level instruments such as keyboards and drum machines. If you find that your instrument has a weak line signal, just plug it into channels 1 – 4 and crank it up with the Gain knob.

Although chances are your microphones will work fine with these mic inputs, we recommend that you do some checking up on the type of microphone you're using, especially if it's one of the older vintage models. Verify that your microphone requires phantom power and make sure its output is low impedance, balanced and floating.

*Always connect your microphones **before** activating phantom power. Microphones tend to be very sensitive, and the sudden power surge can do permanent damage to the mic's circuitry. It's also a good idea to lower mixer levels before you activate phantom power.*

Line Inputs (Channels 5 – 12)

Unlike channels 1 – 4, the line inputs on channels 5 – 12 are stereo inputs that have left and right inputs. If you're using one of these channels as a mono input, plug your instrument into the left input. Channels 5 – 12 don't have the extra gain found on channels 1 – 4 because most line-level instruments don't require the extra boost. Synthesizers and other electronic instruments will work especially well on these channels. These inputs are also good for connecting CD players or tape decks, as these audio sources don't require extra gain.

Digital Output Jack

(Multimix-12FXD and Multimix-16FXD only)

The digital output jack is used to send the 44.1 kHz stereo audio signal to an Alesis Masterlink or any other recording device such as a DAT recorder or a PC with an S/PDIF enabled sound card installed.

Always use a high quality cable when connecting the DIGITAL OUTPUT JACK to your recording device. We recommend that you use a cable that is specifically designed to carry a digital signal and does not exceed 5 meters (16.4 ft) in length.

Any audio signal that is routed to the MAIN OUTPUTS will also be sent out of the DIGITAL OUTPUT jack. The level is controlled by the MAIN FADERS. The DIGITAL OUTPUT mirrors the output from the MAIN OUTPUTS.

PHONE Jack

The headphone jack accepts 1/4" jacks. If your headphones are 1/8", you can find a 1/8" to 1/4" adapter in most electronics stores.

AUX RETURNS

These are the 1/4" jacks where you connect the outputs of an external effects processor or other audio source. Each aux return gives you 15dB of gain that can be controlled by the AUX RET A and EFFECTS / AUX RET B LEVEL knobs in the mixer's output section.

If you are using an effects device with only a mono output, plug it into the left return of STEREO AUX RETURN. It will appear in the center of the stereo spectrum, and not to the left.

AUX SENDS

And this is the 1/4" jack where you connect the line that's going into the input of an external effects processor. The aux sends give you 10dB of gain that can be controlled in the AUX section of each channel input.

ALT 3/4 OUT

These jacks are the outputs for the MultiMix's extra stereo bus. This signal includes channels whose MUTE / ALT 3/4 switch is activated.

2-TRACK

The 2-TRACK IN and OUT jacks are standard RCA jacks. You'll use the OUTs for mixing to a tape deck or other recorder. With the INs you can bring in a signal, which can be monitored and even added to the main mix via the 2TK TO MIX switch in the master section of the mixer.

MAIN MIX OUT

These 1/4" jacks are where the signal on the main mix bus leaves the mixer. From there you can send it to a recorder or a PA system. The level of this signal is controlled by the MAIN MIX fader.

CTRL RM OUT

You can use these 1/4" jacks to send the control room signal to the input of the amplifier driving your monitors or headphones. This output can carry several different signals, depending on which source you have selected in the master section of the mixer.

Channel Strips

The eight channel strips are virtually identical to each other, with the only difference being that channels 1 – 4 are mono and channels 5 – 12 are stereo. Each channel strip contains the following components.

Fader

The fader controls how much of the signal from the mic or line inputs is sent to the channel. To adjust the level, simply slide the fader up and down to the desired level. In the lowest position, levels are cut completely, and in the uppermost position you get an additional 10dB of gain. When the fader is at 0, it is at unity gain, where the level of the output equals the level of the input.

MUTE / ALT 3/4

This switch has two purposes. The mute function is pretty self-explanatory: when you press the switch, the channel's output is no longer routed to the main mix output. The second purpose of this switch is that in addition to muting a channel, it also routes it to the ALT 3/4 OUT found in the patchbay. This is where you get the MultiMix's extra stereo bus. If you don't have anything connected to the ALT 3/4 OUT, the switch acts only as a mute button. If you do have something connected—say, a multitrack recorder—this button acts as a signal router.

PFL / SOLO

The PFL / SOLO switch allows you to single out a channel so you can make adjustments to it before you run it into the main mix. This is useful for setting an instrument's gain or EQ and for

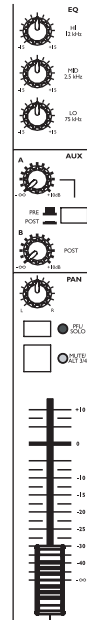

Channel Strip

troubleshooting. PFL stands for “pre-fade listen.” In other words this switch lets you hear the signal before it is affected by the fader. This switch is post-EQ.

PAN or BAL

This control—labeled PAN on the mono channels and BAL on the stereo channels—lets you assign the channel to a particular spot within the stereo spectrum. If you turn this knob to the left, you can hear the signal move to the left, and if you turn it to the right...you get the picture. The pan controls do this by adjusting the amount of the signal being sent to the left main mix bus versus the right main mix bus. The balance controls do it by controlling the relative balance of the left and right channel signals being sent to the left and right main mix buses.

Aux

Here you'll find knobs that control the levels of aux sends A and B. AUX A is either pre-fader or post-fader, depending on the position of the PRE / POST switch. When the switch is in the raised position, the aux send is pre-fader. When the switch is depressed, the aux send is post-fader.

What does all this mean? In POST mode the aux send is affected by the fader, EQ and HPF settings. In PRE mode the aux send is affected only by the EQ and HPF settings. POST mode is generally used for sending the signal to an external effects device (so that the fader controls the signal level), and PRE mode is usually used for cue sends (for example, sending a signal to headphones while recording, for which you may not want the fader to alter the channel's level).

AUX B is always post-fader, as indicated by the word “POST” to the right of this knob. Like AUX A, AUX B can be used for routing signals to external devices. And when you are using the onboard effects processor, AUX B is used to control the level of the channel's signal being routed to the processor.

EQ

The MultiMix gives you three bands of EQ per channel. Using these knobs, you can tailor the channel's signal by boosting some frequencies and cutting others. The LO and HI controls are shelving controls with fixed frequencies of 80 Hz and 12 kHz respectively. The MID control has a peaking response fixed at 2.5 kHz.

“Shelving” means that the mixer boosts or cuts all frequencies past the specified frequency. “Peaking” means that frequencies above and below the specified frequency fall off, forming a peak in a graphical representation.

Master Section

The Master Section is the heart of the mixer, where the channel inputs and aux returns all are mixed together and routed in various ways.

Main Mix Fader

The signals from all channels and aux sends—excluding those that are muted—are sent to the main mix. The MAIN MIX fader is the one you'll use to control the overall level of those combined signals. This fader affects the levels of the signals sent to the MAIN MIX OUT, the DIGITAL OUT (12FXD and 16FXD models only) and the 2-TRACK OUT. In its lowest position the signal is cut off completely, and in the uppermost position you get an additional 10dB of gain. In the 0 position the fader is at unity gain.

Alt 3/4 Fader

This fader controls the output of the Alt 3/4 bus.

2TK To Mix

When you press this switch, the signal coming in through the 2-TRACK IN gets routed to the MAIN MIX, joining whichever other signals are already part of the main mix. Used this way, the 2-TRACK IN effectively becomes another stereo channel (but without all the extras like pan, EQ, etc.).

Alt 3/4 To Mix

This switch adds the signal from the Alt 3/4 bus to the main mix bus.

Solo Mode

The SOLO MODE switch affects the signals of channels whose PFL / SOLO switches are engaged. When the SOLO MODE switch is in the up position, you're in PFL, or pre-fader listen mode. This means that you'll hear the signals of all soloed channels as they sound before they pass through their respective faders. You'll need to be in PFL mode when you're setting levels (see "Setting Channel Levels," page 20. This mode is post-EQ.

When the SOLO MODE switch is engaged (in the down position), you are in SOLO mode. This means that you will hear the output of every soloed channel (after it passes through its fader, pan and EQ).

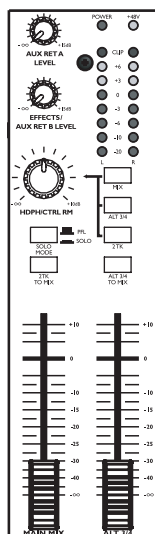

Master Section

The purpose of seeing a soloed channel's level on the LED meters is so that you can see the true level of that channel's signal. For that reason, the HDPH / CTRL RM knob does not change the LED meters' reading—it changes only the level at which you're listening to the soloed channel.

HDPH / CTRL RM

The HDPH / CTRL RM knob controls the level of the signal being sent to the CTRL RM OUT and the PHONES output. The level of this signal is represented by the LED meters. The switches to the right of the HDPH / CTRL RM knob determine the source of the control room mix as explained below. You can use these switches in any combination. If none is selected, you'll hear silence in the control room mix and the LED meters won't light up.

The “CTRL RM” in the name of this knob refers to the fact that it controls the signal that typically is sent to the control room monitors of a studio, where someone—usually an engineer—is working the mixer. However, don't be intimidated if you're using this mixer in your bedroom, which probably isn't equipped with a control room. In this scenario, you can use headphones or connect the CTRL RM OUT to your speakers.

When you solo a channel via its PFL / SOLO switch, that channel's signal will override your control room mix selection. You then will hear only that channel in the control room and the headphones.

MIX Switch

Pressing the MIX switch routes the main mix to the control room level control. When you engage this switch, the channels and aux sends will pass through the MAIN MIX fader and then through the HDPH / CTRL RM level control. You can then keep the MAIN MIX fader set to unity gain for optimal recording, and the HDPH / CTRL RM level control set to a more comfortable listening level if necessary.

ALT 3/4 Switch

When you press the ALT 3/4 switch, the signal from the ALT 3/4 stereo mix bus is routed through the HDPH / CTRL RM level control.

2TK Switch

If you want to monitor the signal coming in from the 2-TRACK jacks, press the 2TK switch.

Aux Ret A Level

This is the level control for the signal returning to the mixer via AUX RETURN A.

Effects / Aux Ret B level

If you are using one of the Multimix's internal effects, this knob controls the effect level. If AUX SEND B is connected to an external device, this knob controls the level for AUX RETURN B.

LED Meters

These are the two rows of yellow, green and red lights you see in the master section of the mixer. They are very versatile, allowing you to view the signal level of the main mix, individual channels (both pre- and post-fader) and aux returns depending on which signal you have routed to the control room mix.

POWER Indicator

When this LED is lit up, that means the POWER ON switch on the rear of the mixer has been activated.

+48V Indicator

When this one is lit up, that means the PHANTOM ON switch on the rear of the mixer has been activated and is supplying +48V phantom power to all XLR mic inputs.

Rear of the Mixer

Here's what you'll find at the rear of the mixer.



Rear

Power Input

Here's where you plug in your mixer's external power supply. You should always connect your power supply to the mixer *before* you plug the power supply into an electrical outlet.

Power Supply Unit

This unit provides 18.5 VAC at 700 mA of power, more than enough to keep your MultiMix running smoothly. As with nearly all power supply units, this one tends to get warm when left on for a while. This is perfectly normal.

*The POWER INPUT is built to accept **only** the power supply unit provided with your MultiMix, or an AC power supply that has the same specs. Others probably will not work.*

Power On

Another easy one. Switch this one on and your mixer has power. Switch it off and it doesn't. Make sure the faders in the master section are pulled all the way down when powering your mixer up or down.

Phantom On

This switch activates and deactivates the phantom power described in “Mic Inputs (Channels 1 – 4),” page 21. This switch controls phantom power for all four mic inputs.



*As we said earlier, it's very important that you plug in your microphones and mute your system **before** you turn on phantom power.*

3 Digital Effects Processor

Onboard your Multimax™ is a powerful effects unit that has 100 preset programs. We offer a few tips on where to use these, but don't limit yourself to our suggestions. We recommend that you experiment with these effects to get a good feel for how they can improve your mixes

Effects Section Components

Program Selection Knob

You can use this knob to assign one of 100 effect programs to your mix. Turning the knob to the right increments the program number, and turning it to the left decrements the program number. You can control the level of the effect for each channel via the channel's AUX B knob. You must PRESS the effect knob to activate the selected effect.

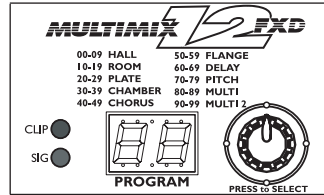

Effects Section

LED Display

This display shows you the number of the current program.

CLIP Indicator

When lit, this LED tells you that there is a signal clip at the internal effects input. This means that you should reduce the signal via the EFFECTS / AUX RET B LEVEL control.

SIG Indicator

When lit, this LED indicates that the effects processor is receiving a signal.

Effect Descriptions

HALL

This type of reverb simulates the ambience of a grand concert hall.

ROOM

This type of reverb reproduces the more intimate ambience of natural room acoustics.

PLATE

These are simulations of metal plate reverbs, as used on classic recordings from the '70s and '80s.

CHAMBER

These are simulations of the reverb created by artificial echo chambers, as used on classic recordings of the '50s and '60s.

CHORUS

These create the effect of multiple voices (or instruments) sounding at once from a single input.

FLANGE

These create a sweeping, swooshing sound effect that you will probably recognize.

DELAY

These effects are based on a discreet repetition or echo of the input.

PITCH

These effects transpose the pitch of the input signal and blend the effect signal with the original to create harmonies.

MULTI & MULTI II

These are combinations of two or more of the above effects.

Your Multimix can be used in a wide variety of ways in both live and recording applications. You have several options for bringing sound into and out of the board. And when it's brought in, you can route it to various parts of the mixer for certain desired effects, or even send it to an external processor or tape deck and back. To give you some ideas for different mixing scenarios, here are descriptions of a few common applications for the Multimix.

Simple Recording Setup

In this setup, you connect your instruments and microphones to the mono and stereo channels, making sure to properly set the level of each channel. You connect your recorder (for example, a 4-track, ADAT, or a tape deck) via the 2-TRACK OUT jack. If you want to output more than two tracks, use the ALT 3/4 OUT. Just remember to activate the MUTE / ALT 3/4 switch for each channel you want to feed into the ALT 3/4 OUT.

You can also connect the DIGITAL OUT to a Masterlink or other stereo recording device with an S/PDIF digital input for a crystal clear mixdown.

You can select one on-board effect and control its level with the AUX B knob for each channel. Or you can use an external effects processor by sending a signal to the external unit via the AUX SEND A and returning it via AUX RETURN A (you'll probably want to set AUX SEND A to POST, for "post-fader."). For monitoring you can connect the CTRL RM OUT jacks to a speaker or headphone amplifier, or just simply plug headphones into the PHONES jack.

Simple Live Setup

This is similar to the recording setup. In a live setup, you most likely will connect the MAIN MIX OUT to a PA system amplifier and the CTRL RM OUT to a headphone amplifier for monitoring purposes. You could also connect a digital equalizer (like the Alesis DEQ-230D) between the DIGITAL OUTPUT and a PA system for extra tone control. Try connecting an external effects processor to the MultiMix's send and receive. Your headphones will allow you to audition a channel before you bring it into the mix, making sure the levels are OK before the audience hears it.

Using Additional External Audio Sources

The Multimix gives you 12 audio inputs in all. If you want to bring external audio sources into a recording or live mix, you can do it in several different ways. Using the 2-TRACK IN, you can add a tape deck, ADAT, CD player or other source to the mix. The 2-TRACK IN also can be used to entertain the audience with a CD as the band is setting up for a live show. The AUX RETURNS can be used as additional audio inputs when you are not using them for effects.

Be sure to use proper cables when connecting instruments and other equipment to the MultiMix. The guidelines on page 19 will help.

Importing Music Into Your Computer

If you would like to import your earlier recordings—or audio from any other source—into your computer, you can use the Multimix to ensure the resulting audio file is mixed properly. Just connect your 4-track, tape deck or other device to the mixer using the 2-TRACK IN or the mixer's channel inputs. The MultiMix's main output should be connected to an input device that is compatible with your computer, and you'll need proper recording software. You can find these in many computer or music stores.

If your PC has a digital sound card with an S/PDIF input jack installed, then simply connect the DIGITAL OUTPUT of your Multimix console to the DIGITAL IN on your PC's sound card. (FXD models only)

* Digital Sound cards with S/PDIF inputs can usually be found in your local music store or on the internet.

Troubleshooting

If you're having problems operating the Multimix, this troubleshooting index will help you correct them.

Symptoms	Cause	Solution
No sound from the mixer.	Mixer is not plugged in or turned on.	Plug in mixer and turn it on.
	Faders are too low.	Raise appropriate faders.
	Control room level is turned down	Turn up control room level.
	The appropriate signal hasn't been assigned to the control room out.	In the master section of the mixer, be sure the right switch is selected (MIX, ALT 3/4 or 2TK)
	Cable is not plugged into output jack.	Check outputs to make sure cables are plugged in securely.
	Headphones are not plugged into PHONE jack.	Plug headphones into PHONE jack.
	Monitor or headphone amplifier is turned off or down.	Turn amplifier on or up.
Audio signal is distorted.	Bad cable.	Check all cables; substitute cables with known good ones.
	Channel level is too high.	Set channel levels using the procedure on page 20.
	Channel input is too high.	Turn down your instrument to a normal volume and then set channel levels using procedure on page 20.
	AUX RET B level is too high.	Lower the level of AUX RET B in the master section of the mixer.
	MAIN MIX level is too high.	Lower the MAIN MIX fader in the master section of the mixer.
Audio signal carries an unwanted hum.	ALT 3/4 level is too high.	Lower the ALT 3/4 fader in the master section.
	Too much low-level noise in the mix.	Engage the channel's high-pass filter by pressing the HPF switch.

	Interference from appliances such as air conditioners.	Engage the channel's high-pass filter by pressing the HPF switch.
	Not using TRS cables.	Make sure you are using 1/4" TRS cables.
Microphone level is too low.	Phantom power is not turned on.	Turn on phantom power using the switch on the rear panel of the mixer.
	Microphone is damaged.	Test the microphone on other audio devices. If you detect damage, contact the manufacturer or dealer.
No or low sound from a channel.	Fader is too low.	Raise channel fader.
	Instrument volume is too low.	Turn up the instrument's volume control. If problem persists, check the instrument by plugging headphones into the instrument's phone jack.
	Channel is muted.	Check the MUTE / ALT 3/4 switch.
	Gain is too low.	Adjust the channel's GAIN control.
Internal effects aren't working.	Effects level is too low.	Turn up the level using the EFFECTS / AUX RET B LEVEL control in the master section of the mixer.
	An effect hasn't been selected.	Press the EFFECTS knob on the desired effect and make sure the SIG indicator is lit.
External effects aren't working.	Effects processor is not plugged in or turned on.	Make sure unit is plugged in and turned on.
	Aux outputs of mixer aren't connected to inputs of processor or processor's outputs aren't connected to mixer's inputs.	Make sure the mixer's aux outputs are connected to the processor's inputs and that the processor's outputs are connected to the mixer's aux inputs.

	Mixer's effects return signal is too low.	Turn up the output of the effects processor or turn up the mixer's AUX RET A RETURN or EFFECTS / AUX RET B RETURN in the master section.
LED meters not working.	Nothing is routed to the HDPH/CTRL RM output.	Press the desired MIX, ALT 3/4 or 2 TK button.
No power.	Incorrect or defective power supply.	Replace with correct power supply (only use Alesis-recommended AC output power supply).

6 Specifications

For the more technical-minded, here are some detailed specifications for the MultiMix's operating levels.

Input Channels

Mic In Sensitivity Range:	-60dBu to -10dBu nominal, +5dBu maximum
Line In Sensitivity Range:	-40dBu to +10dBu nominal, +25dBu maximum
Mic/Line Gain Range:	+10 to +60dB

Equalization

High-Pass Filter:	75Hz, 18dB/octave
High Shelving:	12kHz, +/- 15dB
Mid Bandpass/Band Reject:	2.5 kHz, +/- 15dB
Low Shelving:	80Hz, +/- 15dB

Aux Sends

Aux Send A & B Gain Range: $-\infty$ to +10dB

Aux Returns

Aux Return A Gain Range:	$-\infty$ to +15dB
Effects Level/ Aux Return B Gain Range:	$-\infty$ to +15dB

Channel Levels

Channel Level Gain Range: $-\infty$ to +10dB

Master Levels

Main Mix, Ctrl Room Gain Range: $-\infty$ to +10dB

1/4" Inputs

Stereo Aux Return Level: +4dBu nominal, +20dBu maximum

RCA Inputs

Tape In Level: -10dBV nominal, +5dBV maximum

1/4" Outputs

Main Mix, Ctrl Room, Aux 3/4, Ext Aux Send Level: +4dBu nominal, +20dBu maximum

Headphone Output: 75 ohm output impedance
>105mW into 75 ohms, >40mW into 600ohms

RCA Outputs

Tape Out Level: -10dBV nominal, +5dBV maximum

All measurements done over a 22Hz – 22kHz range with a 1kHz sine wave at +18dBu (-1dBFS) input. Impedances are measured at 1kHz.

Mechanicals**(W x L x H)**

Multimix-12FX:	13.0" x 13.4" x 3.2" / 331mm x 340mm x 80mm, 7.0lbs / 3.2kg
Multimix-12FXD:	13.0" x 13.4" x 3.2" / 331mm x 340mm x 80mm, 7.0lbs / 3.2kg
Multimix-16FXD:	13.0" x 15.2" x 3.2" / 331mm x 386mm x 80mm, 9.7lbs / 4.4kg

7 Block Diagrams

ALESIS
12-CHANNEL ANALOG MIXER w/ DIGITAL OUT

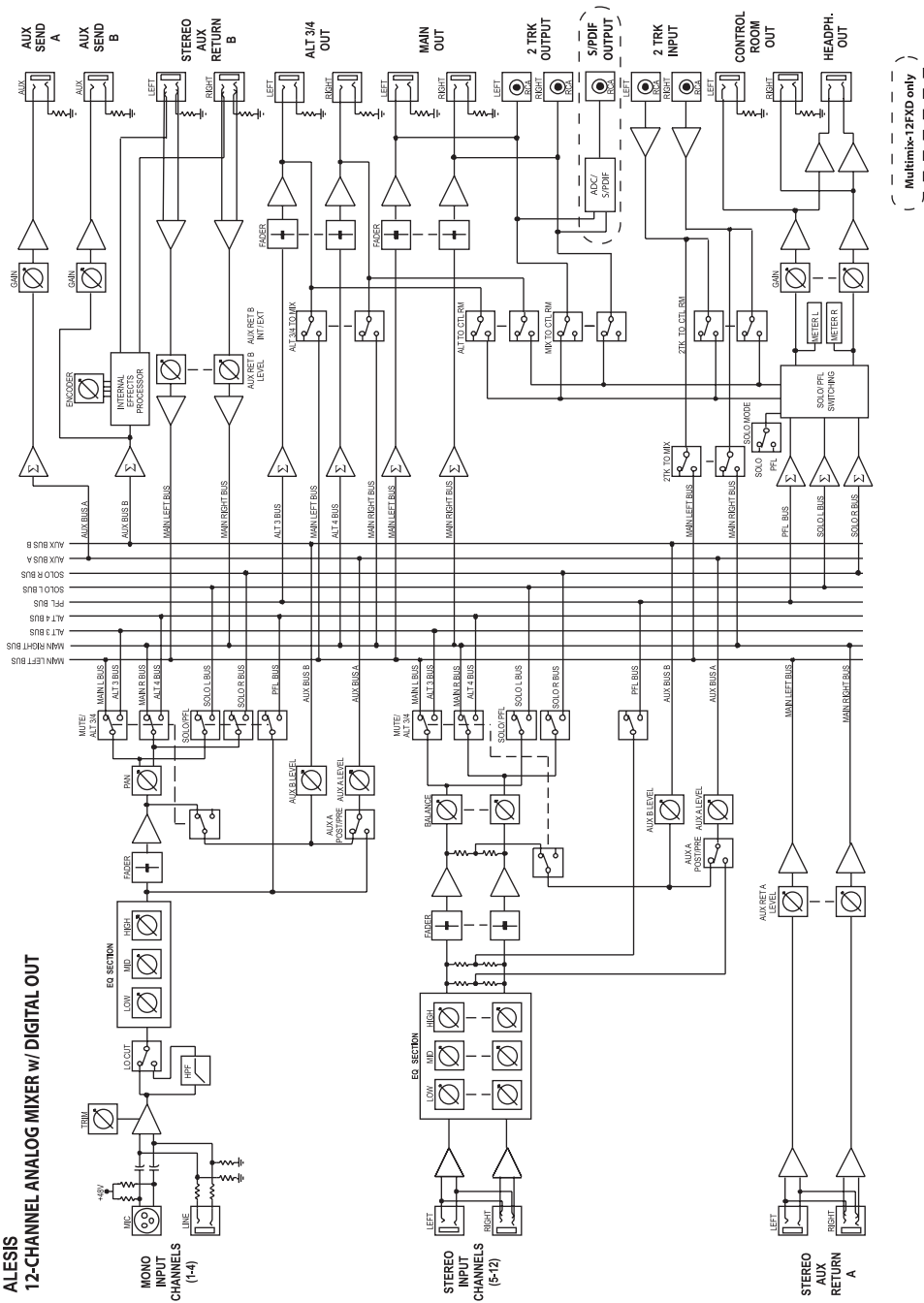

Glossary

Here are the definitions to some terms you'll probably encounter while using your Multimix.

Term	Definition
aux (auxiliary)	An additional set of outputs and inputs found on many mixers. These allow the addition of external effects and other audio sources.
balance	A control that lets you control the position of sound in a stereo signal by altering the relative levels of the left and right channels.
bus	The electrical component that carries signals from multiple sources to a single destination such as an amplifier.
channel	A path through which an audio signal flows.
channel strip	A section of a mixer on which reside controls like a fader, EQ and pan for manipulating the signal of an input channel.
clipping	The cutting of an audio signal caused by a level that is too great for a mixer circuit to handle.
condenser microphone	A type of high-quality microphone that produces a weak signal, usually requiring an external power source like the ones provided by your Multimix's XLR mic inputs.
dB (decibel)	A common unit of measure for audio.
detent	A point of resistance in the path that a mixer knob or fader travels. Detents are used to mark important settings. As you turn the knob or slide the fader, you'll feel it "click" into the detent.
dry	Term used to describe an audio signal free of effects. The opposite of "wet."
dynamic microphone	A common type of microphone that does not require external power. Dynamic microphones are generally cheaper than condenser microphones.
effects processor	A unit whose purpose is to provide effects for audio signals. Some common effects include reverb, chorus, flange and delay. Effects processors come in many shapes and sizes, from small pedals up to rectangular rackmount units.
EQ (equalizer)	The part of your mixer (or other device) that manipulates an audio signal by lowering the level of some frequencies and increasing the levels of others. EQ is used to fine-tune a signal's highs and lows.
fader	A device that allows you to control the level of an audio signal by sliding the fader up and down a straight path. Each input channel of the

Glossary

	Multimix has its own fader, and so do the MAIN MIX and ALT 3/4.
gain	The measure of extra amplification applied to an audio signal. Channels 1 – 4 on your Multimix have gain controls, which are useful for boosting mic and line signals.
level	The amount of power driving an audio signal. The most common names given to levels of varying voltage are, from lowest to highest, microphone level, instrument level and line level.
master section	The section of a mixer where the main mix is controlled.
mic preamp	An amplifier that boosts a microphone-level signal up to line level.
mixer	A device whose purpose is to combine and output a number of audio signals, allowing various types of signal manipulation.
mono (monaural)	Refers to an audio signal that has only one channel. The opposite of stereo.
pan	A control that lets you position a mono signal within the stereo spectrum by altering the level of the signal being sent to the left channel as opposed to the right.
phantom power	A way of providing power to condenser microphones. Called “phantom” because the power isn’t apparent to dynamic microphones when you connect them to an input that provides phantom power.
post-fader	Describes an aux send that sends a signal that already has passed through the channel fader.
pre-fader	Describes an aux send that sends a signal that has not passed through the channel fader.
return	A line input whose function is to carry back to the mixer an audio signal that has been sent from the mixer. Usually used in the application of effects.
send	A line output whose function is to send a signal from the mixer to an external device, usually an effects processor.
stereo	Refers to an audio signal that has two channels.
unity gain	Refers to the setting of an audio channel at which the signal leaves the channel at the same level at which it entered. Unity gain is marked by a 0 on the Multimix’s faders.
wet	An audio signal that has had effects or other manipulations applied. The opposite of “dry.”

Warranty / Contact

Alesis Limited Warranty

ALESIS CORPORATION ("ALESIS") warrants this product to be free of defects in material and workmanship for a period of one (1) year for parts and for a period of one (1) year for labor from the date of original retail purchase. This warranty is enforceable only by the original retail purchaser and cannot be transferred or assigned. For the most effective service, the purchaser should register the purchase on the ALESIS website at <http://www.alesis.com/support/warranty.htm>.

During the warranty period ALESIS shall, at its sole and absolute option, either repair or replace free of charge any product that proves to be defective on inspection by ALESIS or its authorized service representative. In all cases disputes concerning this warranty shall be resolved as prescribed by law.

To obtain warranty service, the purchaser must first call or write ALESIS at the address and telephone number available on the Alesis Website to obtain a Return Authorization Number and instructions concerning where to return the unit for service. All inquiries must be accompanied by a description of the problem. All authorized returns must be sent to ALESIS or an authorized ALESIS repair facility postage prepaid, insured and properly packaged. Proof of purchase must be presented in the form of a bill of sale, canceled check or some other positive proof that the product is within the warranty period. ALESIS reserves the right to update any unit returned for repair. ALESIS reserves the right to change or improve design of the product at any time without prior notice.

This warranty does not cover claims for damage due to abuse, neglect, alteration or attempted repair by unauthorized personnel, and is limited to failures arising during normal use that are due to defects in material or workmanship in the product.

THE ABOVE WARRANTIES ARE IN LIEU OF ANY OTHER WARRANTIES OR REPRESENTATIONS WHETHER EXPRESS OR IMPLIED OR OTHERWISE, WITH RESPECT TO THE PRODUCT, AND SPECIFICALLY EXCLUDE ANY IMPLIED WARRANTIES OF FITNESS FOR A PARTICULAR PURPOSE OR MERCHANTABILITY OR OTHER IMPLIED WARRANTIES. Some states do not allow limitations on how long an implied warranty lasts, so the above limitation may not apply to you. IN NO EVENT WILL ALESIS BE LIABLE FOR INCIDENTAL, CONSEQUENTIAL, INDIRECT OR OTHER DAMAGES RESULTING FROM THE BREACH OF ANY EXPRESS OR IMPLIED WARRANTY, INCLUDING, AMONG OTHER THINGS, DAMAGE TO PROPERTY, DAMAGE BASED ON INCONVENIENCE OR ON LOSS OF USE OF THE PRODUCT, AND, TO THE EXTENT PERMITTED BY LAW, DAMAGES FOR PERSONAL INJURY. Some states do not allow the exclusion or limitation of incidental or consequential damages, so the above limitation or exclusion may not apply to you.

THIS CONTRACT SHALL BE GOVERNED BY THE INTERNAL LAWS OF THE STATE OF CALIFORNIA WITHOUT REFERENCE TO CONFLICTS OF LAWS. This warranty gives you specific legal rights, and you may also have other rights required by law which vary from state to state.

This warranty only applies to products sold to purchasers in the United States of America or Canada. The terms of this warranty and any obligations of Alesis under this warranty shall apply only within the country of sale. Without limiting the foregoing, repairs under this warranty shall be made only by a duly authorized Alesis service representative in the country of sale. For warranty information in all other countries please refer to your local distributor.

For more effective service and product update notices, please register your MultiMix online at:
<http://www.alesis.com/support/warranty.htm>

Alesis Contact Information

Alesis Distribution, LLC
Los Angeles, CA USA

E-mail: support@alesis.com
Web site: <http://www.alesis.com>

Multimix Reference Manual
Revision 1.0 by Edwin Erdmann and Brooks Bruner

Copyright 2002, Alesis Distribution, LLC. All rights reserved
Reproduction in whole or in part is prohibited. "Multimix" is a
trademark of Alesis, LLC. Specifications subject to change without
notice.

7-51-0155-A
7/21/2003

7-51-0155-A