

METAVOX

Reference Manual

ALESIS

This page intentionally left blank



Copyright 2002, Alesis. All rights reserved
Reproduction in whole or in part is prohibited.
Specifications subject to change without notice.
All trademarks are the property of their respective holders.

7-51-0117-A
8/2002

Table of Contents

| | |
|---|-----------|
| Introduction | 3 |
| Welcome! | 3 |
| About the Metavox | 4 |
| Important features of your Metavox | 4 |
| Metavox Key Features | 5 |
| How to Use This Manual | 6 |
| Safety Instructions/Notices | 7 |
| Important Safety Instructions (English) | 7 |
| CE Declaration Of Conformity | 9 |
| FCC Compliance Statement | 9 |
| Instructions de Sécurité Importantes (French) | 10 |
| Lesen Sie bitte die folgende Sicherheitshinweise (German) | 12 |
| Quick Start Guide | 15 |
| If you can't wait to get started..... | 15 |
| Hookup for voice modulation of a synthesizer | 15 |
| A quick overview of the controls | 16 |
| Rear Panel..... | 16 |
| Connections | 17 |
| Unpacking and Inspection..... | 17 |
| Installing in a Rack | 17 |
| Power..... | 17 |
| Connecting to the Channel Inserts of a mixing console: | 20 |
| Connecting to the Group Sends or Aux Send/Return of a mixing console:..... | 21 |
| Connecting to the inserts on an instrument amplifier: | 22 |
| Connecting to equipment with XLR inputs and outputs:..... | 23 |
| About audio cables..... | 23 |
| Using the ModLink | 24 |
| Using the Metavox | 25 |
| About Vocoding | 25 |
| What is Tempo Sync? | 27 |
| To turn Tempo Sync off:..... | 27 |
| Description of Controls | 28 |
| Synthesis Input Switch | 28 |
| Phreeq..... | 29 |
| Sibalance..... | 29 |
| Modulation switch..... | 30 |
| Depth..... | 32 |
| Rate | 32 |
| Reset Mod..... | 33 |
| Tap Tempo | 33 |
| Bypass | 34 |
| Using the Foot Switch | 34 |

Sample Settings.....35
Blank Settings Templates38

Troubleshooting.....39
Troubleshooting Index.....39
Avoiding ground loop noise.....41
Line conditioners and spike protectors42

Care and Maintenance43
Cleaning.....43
Refer all servicing to Alesis.....43
Obtaining repair service44

Specifications.....45
Audio Input.....45
Audio Output.....45
Audio Performance.....45
Mechanical45

Index.....47

Warranty/Contact Alesis48
Alesis Limited Warranty48
Alesis Contact Information49

Introduction

Welcome!

Thank you for making the Alesis Metavox a part of your studio. Since 1984, we've been designing and building creative tools for the audio community. We believe in our products, because we've heard the results that creative people like you have achieved with them. One of Alesis' goals is to make high-quality studio equipment available to everyone, and this Reference Manual is an important part of that. After all, there's no point in making equipment with all kinds of capabilities if no one explains how to use them. So, we try to write our manuals as carefully as we build our products.

The goal of this manual is to get you the information you need as quickly as possible, with a minimum of hassle. We hope we've achieved that. If not, please drop us an email and give us your suggestions on how we could improve future editions of this manual.

We hope your investment will bring you many years of creative enjoyment and help you achieve your goals.

Sincerely,
The people of Alesis

For more effective service and product update notices, please register your Metavox online at:

<http://www.alesis.com/support/warranty.htm>

Introduction

About the Metavox

Your new Metavox is a member of the Alesis ModFX family of performance effects boxes. The Metavox is a vocoder with a built-in oscillator that can be modulated by the amplitude and tone of any input (usually a human voice) to produce unique “talking” effects.

Each box in the line provides a different set of sound effects and signal processing, and they are easy to arrange and connect to each other. With a uniform, friendly, uncomplicated user interface and high-resolution digital processing, the ModFX product line is perfect for keyboardists, guitarists, and any other studio or live performance artists.

Important features of your Metavox

High Resolution Processing

Internally the Metavox uses 28-bit stereo digital signal processing. The digital-to-analog and analog-to-digital conversion is sampled at 48kHz with 24 bits of resolution. That means you can get the effect you want, without adding unwanted noise and distortion.

ModLink

If you're using multiple ModFX boxes to make your own unique effects chain, ModLink makes it easy to hookup without needing patch cords within the chain. The nine-pin connectors built into each side of the case enable a ModFX box to transfer digital audio and word clock directly to another. Any number of units can be connected together.

Vocoding of internal or external sources

The Metavox features a built-in oscillator section, complete with several kinds of modulation, that can be controlled by an incoming stereo signal. Alternatively, it can produce a vocoding effect on any external source plugged into the right input, with the controlling (voice) source plugged into the left input.

Metavox Key Features

- One-oscillator vocoder with four built-in waveforms (saw, rectified saw, square, and noise) in a compact box
 - Can vocode external sources, for polyphonic vocoding of an external synthesizer, guitar, etc.
 - Built-in modulation of internal oscillator by any of five different mod sources
 - Tempo Sync keeps modulation in time with the music
 - Tap Tempo makes it easy to set the speed of modulation by tapping a beat on the top panel
 - Reset Mod lets you reset the phase of any modulation shape from its beginning
 - Uniform, friendly, uncomplicated user interface—no fiddling with complicated menus or “hidden” knobs
 - Stereo processing via four 1/4” unbalanced connectors
 - ModLink port, a cable-free connection that transfers digital audio and word clock to other ModFX units
 - Footswitch connection to control the bypass function
 - Ability to mount 3 ModFX boxes in the optional ModFX rack adapter
 - Input trim control to adjust input level
 - Internal 28-bit digital processing
 - 24-bit D/A and A/D conversion at 48kHz sampling rate for quiet, distortion-free effects
 - External 9VAC power supply included
-

Introduction

How to Use This Manual

A little technical knowledge will help you get the most out of your gear...it's really pretty simple. This manual is divided into the following sections describing the various functions and applications for the Metavox. While it's a good idea to read through the entire manual once carefully, those having general knowledge about effect devices should use the table of contents to look up specific functions.

Chapter 1: Quick Start. If you're already experienced with effect boxes, this will get you started using the Metavox right away. It's a short guide to the essential elements of hooking it up and using it for the first time. A brief tour of the front and rear panels also directs you to the chapters focused on individual features.

Chapter 2: Connections gives detailed instructions for connecting the Metavox to a variety of typical audio systems. It also discusses the process of linking the Metavox with other ModFX devices.

Chapter 3: Using the Metavox explains the controls of the Metavox and their functions.

Chapter 4: Sample Settings provides a selection of sound charts created by the sound designers at Alesis for you to try.

Near the end of the manual are troubleshooting tips, specifications, and an index to help you find what you're looking for.

Helpful tips and advice are highlighted in a shaded box like this



When something important appears in the manual, an exclamation mark (like the one shown at left) will appear with some explanatory text. This symbol indicates that this information is vital when operating the Metavox.

Safety Instructions/Notices

Important Safety Instructions (English)

Safety symbols used in this product



This symbol alerts the user that there are important operating and maintenance instructions in the literature accompanying this unit.



This symbol warns the user of uninsulated voltage within the unit that can cause dangerous electric shocks.



This symbol warns the user that output connectors contain voltages that can cause dangerous electrical shock.



Please follow these precautions when using this product:



1. Read these instructions.
2. Keep these instructions.
3. Heed all warnings.
4. Follow all instructions.
5. Do not use this apparatus near water.
6. Clean only with a damp cloth. Do not spray any liquid cleaner onto the faceplate, as this may damage the front panel controls or cause a dangerous condition.
7. Install in accordance with the manufacturer's instructions.
8. Do not install near any heat sources such as radiators, heat registers, stoves, or other apparatus (including amplifiers) that produce heat.
9. Do not defeat the safety purpose of the polarized or grounding-type plug. A polarized plug has two blades with one wider than the other. A grounding-type plug has two blades and a third grounding prong. The wide blade or the third prong are provided for your safety. When the provided plug does not fit into your outlet, consult an electrician for replacement of the obsolete outlet.
10. Protect the power cord from being walked on or pinched, particularly at plugs, convenience receptacles, and the point where they exit from the apparatus.

Continued next page

Important Safety Instructions

11. Use only attachments or accessories specified by the manufacturer.
-  12. Use only with a cart, stand, bracket, or table designed for use with professional audio or music equipment. In any installation, make sure that injury or damage will not result from cables pulling on the apparatus and its mounting. If a cart is used, use caution when moving the cart/apparatus combination to avoid injury from tip-over.
13. Unplug this apparatus during lightning storms or when unused for long periods of time.
-  14. Refer all servicing to qualified service personnel. Servicing is required when the apparatus has been damaged in any way, such as when the power-supply cord or plug is damaged, liquid has been spilled or objects have fallen into the apparatus, the apparatus has been exposed to rain or moisture, does not operate normally, or has been dropped.
15. This unit produces heat when operated normally. Operate in a well-ventilated area with at least six inches of clearance from peripheral equipment.
16. This product, in combination with an amplifier and headphones or speakers, may be capable of producing sound levels that could cause permanent hearing loss. Do not operate for a long period of time at a high volume level or at a level that is uncomfortable. If you experience any hearing loss or ringing in the ears, you should consult an audiologist.
17. Do not expose the apparatus to dripping or splashing. Do not place objects filled with liquids (flower vases, soft drink cans, coffee cups) on the apparatus.
18. **WARNING:** To reduce the risk of fire or electric shock, do not expose this apparatus to rain or moisture.

CE Declaration Of Conformity

See our website at:

<http://www.alesis.com>

FCC Compliance Statement

This device complies with Part 15 of the FCC rules. Operation is subject to the following two conditions: (1) This device may not cause harmful interference and (2) this device must accept any interference received, including interference that may cause undesired operation.

NOTE: This equipment has been tested and found to comply with the limits for a Class B digital device, pursuant to Part 15 of the FCC Rules. These limits are designed to provide reasonable protection against harmful interference in a residential installation. This equipment generates, uses and can radiate radio frequency energy and, if not installed and used in accordance with the instructions, may cause harmful interference to radio communications. However, there is no guarantee that interference will not occur in a particular installation. If this equipment does cause harmful interference to radio or television reception, which can be determined by turning the equipment off and on, the user is encouraged to try to correct the interference by one or more of the following measures:

- Reorient or relocate the receiving antenna.
- Increase the separation between the equipment and receiver.
- Connect the equipment into an outlet on a circuit different from that to which the receiver is connected.
- Consult the dealer or an experienced radio/TV technician for help.

Instructions de Sécurité Importantes (French)

Symboles utilisés dans ce produit



Ce symbole alerte l'utilisateur qu'il existe des instructions de fonctionnement et de maintenance dans la documentation jointe avec ce produit.



Ce symbole avertit l'utilisateur de la présence d'une tension non isolée à l'intérieur de l'appareil pouvant engendrer des chocs électriques.



Ce symbole prévient l'utilisateur de la présence de tensions sur les raccords de sorties, représentant un risque d'électrocution.

Veillez suivre ces précautions lors de l'utilisation de l'appareil:



1. Lisez ces instructions.
2. Gardez ces instructions.
3. Tenez compte de tous les avertissements.
4. Suivez toutes les instructions.
5. N'utilisez pas cet appareil à proximité de l'eau.
6. Ne nettoyez qu'avec un chiffon humide. Il est potentiellement dangereux d'utiliser des pulvérisateurs ou nettoyeurs liquides sur cet appareil.
7. Installez selon les recommandations du constructeur.
8. Ne pas installer à proximité de sources de chaleur comme radiateurs, cuisinière ou autres appareils (dont les amplificateurs) produisant de la chaleur.
9. Ne pas enlever la prise de terre du cordon secteur. Une prise murale avec terre deux broches et une troisième reliée à la terre. Cette dernière est présente pour votre sécurité. Si le cordon secteur ne rentre pas dans la prise de courant, demandez à un électricien qualifié de remplacer la prise.
10. Évitez de marcher sur le cordon secteur ou de le pincer, en particulier au niveau de la prise, et aux endroits où il sort de l'appareil.

Suite de la page suivante

11. N'utilisez que des accessoires spécifiés par le constructeur.



12. N'utilisez qu'avec un stand, ou table conçus pour l'utilisation d'audio professionnel ou instruments de musique. Dans toute installation, veillez de ne rien endommager à cause de câbles qui tirent sur des appareils et leur support.



13. Débranchez l'appareil lors d'un orage ou lorsqu'il n'est pas utilisé pendant longtemps.

14. Faites réparer par un personnel qualifié. Une réparation est nécessaire lorsque l'appareil a été endommagé de quelque sorte que ce soit, par exemple lorsque le cordon secteur ou la prise sont endommagés, si du liquide a coulé ou des objets se sont introduits dans l'appareil, si celui-ci a été exposé à la pluie ou à l'humidité, ne fonctionne pas normalement ou est tombé.

15. Puisque son fonctionnement normale génère de la chaleur, placez cet appareil au moins 15cm. des équipements périphériques et assurez que l'emplacement permet la circulation de l'air.

16. Ce produit, utilisé avec un amplificateur et un casque ou des enceintes, est capable de produire des niveaux sonores pouvant engendrer une perte permanente de l'ouïe. Ne l'utilisez pas pendant longtemps à un niveau sonore élevé ou à un niveau non confortable. Si vous remarquez une perte de l'ouïe ou un bourdonnement dans les oreilles, consultez un spécialiste.

17. N'exposez pas l'appareil à l'égoutture ou à l'éclaboussement. Ne placez pas les objets remplis de liquides (vases à fleur, boîtes de boisson non alcoolique, tasses de café) sur l'appareil.

18. **AVERTISSEMENT:** Pour réduire le risque du feu ou de décharge électrique, n'exposez pas cet appareil à la pluie ou à l'humidité.

Important Safety Instructions

Lesen Sie bitte die folgende Sicherheitshinweise (German)

Sicherheit Symbole verwendet in diesem Produkt



Dieses Symbol alarmiert den Benutzer, daß es wichtige Funktionen und Wartung Anweisungen in der Literatur gibt, die diese Maßeinheit begleitet.



Dieses Symbol warnt den Benutzer der nicht isolierten Spannung innerhalb der Maßeinheit, die gefährliche elektrische Schläge verursachen kann.



Dieses Symbol warnt den Benutzer, dem Ausgabestecker Spannungen enthalten, die gefährlichen elektrischen Schlag verursachen können.

Folgen Sie bitte diesen Vorkehrungen, wenn dieses Produkt verwendet wird:



1. Lesen Sie die Hinweise.
2. Halten Sie sich an die Anleitung.
3. Beachten Sie alle Warnungen.
4. Beachten Sie alle Hinweise.
5. Bringen Sie das Gerät nie mit Wasser in Berührung.
6. Verwenden Sie zur Reinigung nur ein weiches Tuch. Verwenden Sie keine flüssigen Reinigungsmittel. Dies kann gefährliche Folgen haben.
7. Halten Sie sich beim Aufbau des Gerätes an die Angaben des Herstellers.
8. Stellen Sie das Gerät nicht in der Nähe von Heizkörpern, Heizungsklappen oder anderen Wärmequellen (einschließlich Verstärkern) auf.
9. Verfehlen Sie nicht den Zweck des grounding Terminals auf dem Netzstecker. Dieses Terminal wird für Ihre Sicherheit zur Verfügung gestellt.
10. Verlegen Sie das Netzkabel des Gerätes niemals so, daß man darüber stolpern kann oder daß es gequetscht wird.

Fortsetzung auf nächster Seite

Important Safety Instructions

11. Benutzen Sie nur das vom Hersteller empfohlene Zubehör.



12. Verwenden Sie ausschließlich Wagen, Ständer, oder Tische, die speziell für professionelle Audio- und Musikinstrumente geeignet sind. Achten Sie immer darauf, daß die jeweiligen Geräte sicher installiert sind, um Schäden und Verletzungen zu vermeiden. Wenn Sie einen Rollwagen benutzen, achten Sie darauf, das dieser nicht umkippt, um Verletzungen auszuschließen.

13. Ziehen Sie während eines Gewitters oder wenn Sie das Gerät über einen längeren Zeitraum nicht benutzen den Netzstecker aus der Steckdose.



14. Die Wartung sollte nur durch qualifiziertes Fachpersonal erfolgen. Die Wartung wird notwendig, wenn das Gerät beschädigt wurde oder aber das Stromkabel oder der Stecker, Gegenstände oder Flüssigkeit in das Gerät gelangt sind, das Gerät dem Regen oder Feuchtigkeit ausgesetzt war und deshalb nicht mehr normal arbeitet oder heruntergefallen ist.

15. Dieses Gerät produziert auch im normalen Betrieb Wärme. Achten Sie deshalb auf ausreichende Lüftung mit mindestens 15 cm Abstand von anderen Geräten.

16. Dieses Produkt kann in Verbindung mit einem Verstärker und Kopfhörern oder Lautsprechern Lautstärkepegel erzeugen, die anhaltende Gehörschäden verursachen. Betreiben Sie es nicht über längere Zeit mit hoher Lautstärke oder einem Pegel, der Ihnen unangenehm ist. Wenn Sie ein Nachlassen des Gehörs oder ein Klingeln in den Ohren feststellen, sollten Sie einen Ohrenarzt aufsuchen.

17. Setzen Sie den Apparat nicht Bratenfett oder dem Spritzen aus. Plazieren Sie die Nachrichten, die mit Flüssigkeiten (gefüllt werden Blumenvases, Getränkdosen, Kaffeetassen) nicht auf den Apparat.

18. **WARNING:** um die Gefahr des Feuers oder des elektrischen Schlages zu verringern, setzen Sie diesen Apparat nicht Regen oder Feuchtigkeit aus.

Important Safety Instructions

This page intentionally left blank.

1 Quick Start Guide

If you can't wait to get started

The Alesis Metavox is a unique product, and is inherently different from other effects units. If you've already used a vocoder device, this chapter is a "shorthand" guide for those who want to start using the Metavox right away in the most popular way. If you have questions about any of the features, don't worry – later chapters will unveil the mysteries of the Metavox's special features.

Hookup for voice modulation of a synthesizer

1. First, make sure the power is off to all the components you're connecting to: amp, mixer, and instruments.
2. Pull the Metavox and its power supply out of the package.
3. Using a 1/4" instrument cable, plug the output of the synthesizer into the RIGHT INPUT on the back of the Metavox.
4. Plug the output of a microphone preamplifier (or the DIRECT OUT of a mixer channel with a microphone plugged into it) into the Metavox's LEFT INPUT.
5. Connect the OUTPUTS of the Metavox to the inputs of a mixer, powered speakers, or instrument amplifier.
6. Insert the power jack of the Metavox's power adapter into the POWER 9VAC input on the rear panel of the Metavox and plug the power adapter into an AC outlet (preferably on a power strip with its switch off).

The Metavox doesn't have a POWER switch of its own. The moment you plug in the power, its top panel LEDs will come on.

7. Turn the power on to the system: the keyboard, then the Metavox's power strip (if it's not already on), then the mixer, then the amp.
8. Turn the INPUT TRIM knob on the back of the Metavox while talking into the microphone to adjust the input level. The SIGNAL LED on the top panel will light green, not red, when the level is correct.
9. Set the [SYNTHESIS INPUT] switch to RIGHT IN = SYNTH. Hold a sustained keyboard sound while talking into the microphone. (The other controls of the Metavox have no effect in this mode.)

For more detailed information on connecting the Metavox, see chapter 2: Connections, especially the diagram on page 19.

If you're new to vocoding...

start with the more detailed instructions for hookup and operation starting in the next chapter.

Left and right input levels

Adjust your microphone preamp so it puts out a strong line level. The INPUT TRIM control does not affect the synthesizer (right input) level; adjust the level on the instrument itself.

1 Quick Start Guide

A quick overview of the controls

SYNTHESIS INPUT

This selects the internal oscillator wave or external input (as shown by the LEDs next to the switch) that will be vocoded by the input.

Reset Mod

Restarts the modulation from the beginning of its cycle. Generates a trigger in TRIGGERED mode, or changes the pattern in PATTERN mode.

PHREEQ sets the frequency of the internal oscillator when SYNTHESIS IN is set to SAW, RECTIFIED or SQUARE.

SIBILANCE controls how much of the high-end consonant sounds will be injected into the vocoder's output.

BYPASS lets signal pass through without any effects.

RATE affects the speed of modulation, in cooperation with TEMPO SYNC and the TAP TEMPO button. See page 33..

DEPTH controls how much the internal oscillator will be modulated.

The MODULATION functions

have effect **only** if the SYNTHESIS INPUT switch is set to SAW, RECTIFIED, or SQUARE.

Tap Tempo

If MODULATION is in TEMPO SYNC mode, tap a beat on this button, and the speed of the modulation will be set at some multiple of that beat, as set by the RATE knob.

MODULATION switch selects what kind of mod source will be applied to the internal SAW or SQUARE wave, and whether the Modulation speed is in Tempo Sync mode (see LEDs to the left)

Signal LED

When this lights green, the Metavox is getting an input signal. When it's red, it's seeing too much level...so turn down the instrument...

...or the TRIM control here on the back panel. NOTE: this controls ONLY the LEFT input, and has no effect on the right.

Rear Panel

Plug the power adapter in here.

The FOOT SWITCH may be connected to any momentary pedal, to engage the BYPASS function.

The ModLink connectors let you arrange several ModFX units in a chain, without having to use input and output cables inside the chain.

INPUTS and OUTPUTS are standard 1/4" line-level jacks. To vocode an external source, plug the source into

the right jack and the microphone preamp into the left jack.

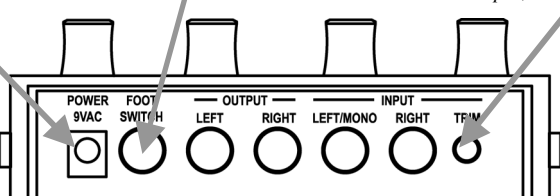
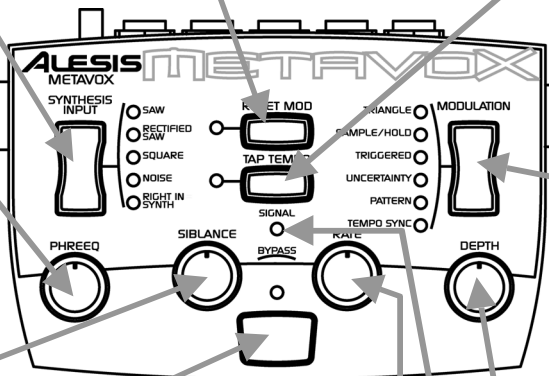

2 Connections

Unpacking and Inspection

Your Metavox was packed carefully at the factory. The shipping carton was designed to protect the unit during shipping. Please retain this container in the highly unlikely event that you need to return the Metavox for servicing.

The shipping carton should contain the following items:

- Metavox with the same serial number as shown on the shipping carton
- Power Adapter
- This instruction manual

To register your purchase, go to the Alesis website at www.alesis.com.

Installing in a Rack

The Metavox is designed for tabletop use, but can also be installed in a standard 19" audio equipment rack. For rack mounting, contact your Alesis dealer for the ModFX Rack. This rack shelf holds three ModFX units in a 3-space high 19" rack.

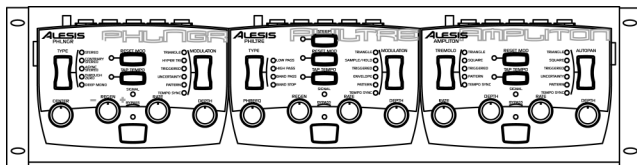

Power

The Metavox comes with an AC power adapter that transforms the voltage from a standard outlet into 9 volts AC (830 mA). Plug the small end of the power adapter cord into the Metavox's POWER INPUT socket and then plug the adapter itself into a good quality, noise-free AC power source of the proper rating.

The supplied AC line adapter is designed only for the destination to which the unit is shipped. To use the Metavox in another country, contact your Alesis dealer for an Alesis P3 adapter suitable for the electrical system in the country you are traveling to.

! Make sure you read the initial Important Safety Instructions chapter at the front of this manual.

Avoid "popping":
Don't plug the power adapter into the Metavox until all other audio cables have been hooked up. Make sure your amplifier or powered speakers are switched off when plugging in the Metavox to avoid damage.

Connecting audio

The Metavox will work in many different applications, whether you are connecting an instrument directly into it, or connecting it through a mixing console.

Signal processor vs. synthesizer

Unlike other signal processors, a vocoder is half processor, half synthesizer. A signal processor takes an input signal and makes it sound different. But a vocoder uses an input signal (usually from a microphone) to control the amplitude and tone of an internal oscillator (or an external input); none of the controlling signal is mixed in with the output signal. Because of this, a vocoder is usually connected in a different way from most other signal processors. For example, it's not likely that you'll connect the Metavox in the effect send/return path of a mixing console.

Mic preamplification options

To get the classic “talking guitar” or “talking robot” sounds associated with vocoding, you'll probably want to use a vocal microphone as the controlling input of the Metavox. Since microphones are low-output devices, they must be amplified to line level before the Metavox can “read” them. You have several options for this:

- **Direct Out of mixer channel:** Connect a microphone to a mixer channel. Adjust the channel's input gain (trim) in the normal way to get a strong output. Connect the DIRECT OUT of the mixer channel to the [LEFT INPUT] of the Metavox. If possible, turn off any assignment switches in the mixer channel to the groups or stereo mixes.
- **Outboard mic preamp:** Especially for live use, it may be a good idea to get a small mic preamp and dedicate a special microphone just for vocoding use to it. Connect the output of the preamp to the [LEFT INPUT] of the Metavox.
- **Aux send of mixer:** If your mixer has an extra pre-fader aux send or monitor send, connect the output of that mix to the left input of the Metavox. This has the advantage of letting several different sources be the controller.
- **Insert point:** If you don't have a DIRECT OUT on your mixer, sometimes the INSERT point can act as a pre-fader direct out by plugging a 1/4" cable in to the “first click” (about 1/4" before the plug is all the way in) without interrupting the signal flow to the mixer. Or, if you use a regular insert cable connected to the input and output of the Metavox, the microphone level will be set by the TRIM of the channel, and the channel will “hear” the output of the Metavox.

When connecting audio cables and/or turning power on and off, make sure that all devices in your system are turned off and the volume controls are turned down.

If you're using a high-output dynamic microphone, a good-quality passive line transformer might provide enough gain to control the Metavox, with the [TRIM] control up full.

Typical vocoding setup

If you're connecting an instrument directly to the Metavox, hook it up this way:

1. Connect a 1/4" phone cord to the [RIGHT INPUT] of the Metavox from the instrument you want to have vocoded.
Or, you can just use the Metavox's own waveforms as the synthesis input source.
2. Connect another 1/4" phone cord from the microphone preamplifier or mixer's direct output to the [LEFT INPUT] (as shown below).
3. Connect two 1/4" phone cords from the [LEFT] and [RIGHT OUTPUTS] of the Metavox to two mixer inputs.
4. If you're connecting directly to a stereo mixer, pan the two channels hard left and hard right to get the maximum effect.
5. To vocode the instrument, set [SYNTHESIS INPUT] to RIGHT IN = SYNTH. Otherwise, use either the microphone or the instrument to control the internal oscillator.

INPUT TRIM affects only the left input

Once you've set your microphone preamp gain, crank up the [INPUT TRIM] control on the back of the Metavox until the SIGNAL LED on its top panel flashes red while you talk, then back it off a bit.

Most guitars and basses have relatively low output levels. For the quietest effect, turn up the volume on the guitar to full. If that's not enough, don't change the INPUT TRIM of the Metavox. Instead, plug the guitar into a mixer channel or other preamp first.

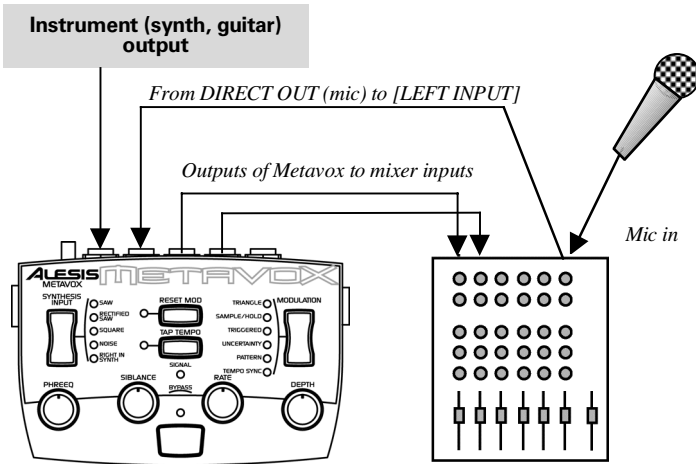

Connecting to the Channel Inserts of a mixing console:

Most recording consoles have a jack near the mic and line inputs labeled "Insert". This is typically a TRS jack with the send and return on the same jack. To use the Metavox as a channel insert, you will need an insert cable (not included).

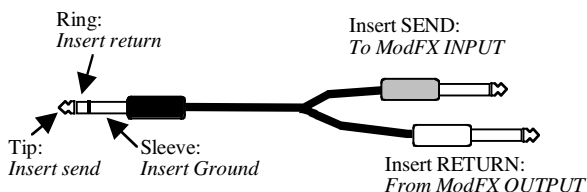

This cable splits the TRS insert jack into two unbalanced mono connectors. Usually, the tip is connected to the INPUT of the Metavox and the ring is connected to the OUTPUT of the Metavox. However, this may be reversed on some recording consoles. Check your mixer's Reference Manual to be sure or just try it both ways – this won't damage the Metavox.

For stereo operation, you would use two insert cables, inserted into two adjacent channels of the mixer. One would send and receive signal to the left channel of the Metavox, and the pan pot of that mixer channel would normally be panned to the left. Pan the next mixer channel, for the right side of the Metavox, to the right.

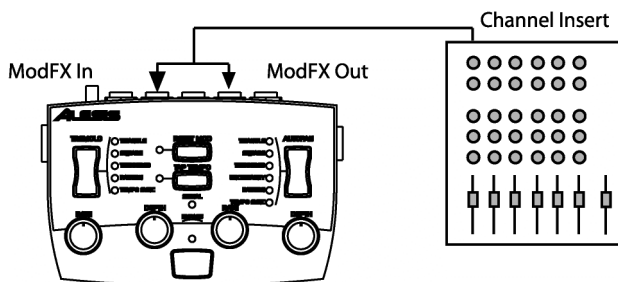

Left and right split

When using the insert cables this way, the RIGHT channel can be the instrument being vocoded (synth or guitar) and the LEFT channel is the voice source (from the microphone). Set SYNTHESIS INPUT to RIGHT IN = SYNTH.

Connecting to the Group Sends or Aux Send/Return of a mixing console:

The Metavox is designed more for in-line processing than the send/receive kind of processing typically used for reverb units. However, plugging the Metavox into a Group or Aux send/return loop will allow you to vocode a mix of several instruments, from any mixer channel assigned to that group.

The principle of operation is this: you use one mix bus (a group, or auxiliary send) as the vocoding source (the modulator), and another mix bus as the instrument mix to be processed (the carrier). This will make it easy to select different mics to be the controller, and vocode different instrument/synthesis sources with those mics. This is also necessary if you want to mix some of the original controller or instrument sound back into the main mix, instead of just hearing the vocoded result from the Metavox.

To do this, connect a single cable from the Group or Aux Send Out to the [LEFT/MONO] input of the Metavox. Assign a microphone to this Group, or bring up the Aux Send on the microphone channel only with all other aux sends down.

Connect another cable from a different Group or Aux Send to the [RIGHT INPUT] of the Metavox. Use two separate cables to connect the [LEFT OUTPUT] and [RIGHT OUTPUT] of the Metavox to the left and right inputs of a Stereo Effect Return, or to two adjacent mixer channels panned to left and right.

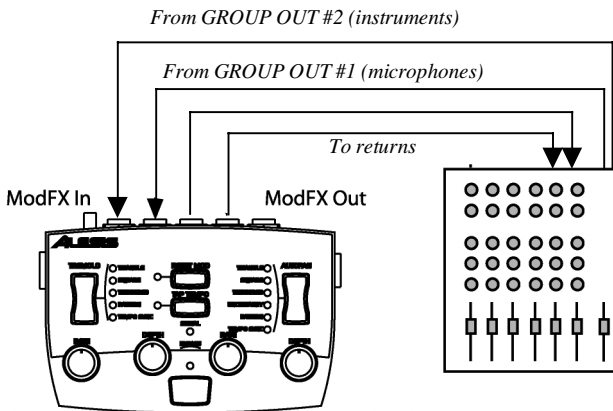

If you use mixer channels for the returns from the Metavox, be sure the Group Sends for those channels are turned off to avoid feedback.

In this example, any microphone anywhere in the console assigned to Group 1 can be a vocoder control source. Any sound mixed to Group 2 will be vocoded by that microphone and sent to the output of the Metavox.

Connecting to the inserts on an instrument amplifier:

Use this method **only** if you occasionally use the Metavox to provide synthesizer sounds and noises under control of your guitar. This method won't let any guitar sound through unless BYPASS is pressed.

The insert send on a guitar or bass amp is usually labeled "effects send and return" or "insert send and return". This allows you to preamplify your instrument before vocoding it and sending it to the power amp.

Most guitar amps are single channel, so connect a single insert cable from the amp to the LEFT INPUT and LEFT OUTPUT of the Metavox. Some amps have separate "effect send" and "effect return" jacks; for these, use standard cables. Check the manual of your amplifier for details.

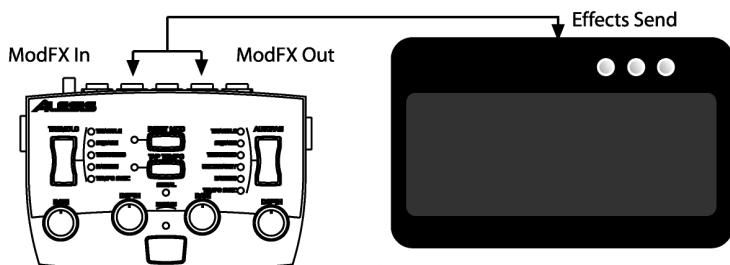

If you are using a dedicated rack-mount preamplifier, another method would be to insert the Metavox between the preamp and the input(s) of the power amp.

Never connect the Metavox between the power amp and the speaker!

The high power levels created by the power amp will destroy the circuitry of the Metavox.

Connecting to equipment with XLR inputs and outputs:

If you are connecting the Metavox to a product with XLR balanced inputs and outputs, you will need to convert this signal to a 1/4" unbalanced connector. Make sure that **Pin 2** of the XLR connector is connected to the **Tip** of the 1/4" adapter or cable.

Watch out for high levels, however: some XLR sources put out levels close to the maximum the Metavox can accept (about +12 dBu) even when its trim is at minimum. Lower the level of the source if the [SIGNAL] LED flashes red.

About audio cables

The connections between the Metavox and your studio are your music's lifeline, so use only high quality cables. These should be low-capacitance shielded cables with a stranded (not solid) internal conductor and a low-resistance shield. Although quality cables cost more, they do make a difference.

Route cables to the Metavox correctly by observing the following precautions:

- Do not bundle audio cables with AC power cords.
- Avoid running audio cables near sources of electromagnetic interference such as transformers, monitors, computers, etc.
- Do not place cables where they can be stepped on. Stepping on a cable may not cause immediate damage, but it can compress the insulation between the center conductor and shield (degrading performance) or reduce the cable's reliability.
- Avoid twisting the cable or having it make sharp, right angle turns.
- Never unplug a cable by pulling on the wire itself. Always unplug by firmly grasping the body of the plug and pulling directly outward.

Don't use line transformers:

Many XLR-to-1/4" adapters sold at electronics stores are NOT adapters, but transformers (and very low quality transformers at that). Don't use these on the output of the Metavox—they're unnecessary and generally sound awful because they don't have the headroom to handle the Metavox's output. Get a hard-wired adapter or cable from your professional audio dealer, or make one yourself from components.

However, a mic-to-line transformer might work to provide a vocoding input to the Metavox.

Using the ModLink

The Metavox can be connected to other effect boxes in the ModFX family via the ModLink. The ModLink is a cable-free connection between two ModFX units that transfers digital audio and word clock. The 9-pin male connector on the left side of the unit is the ModLink IN port. The 9-pin female connector on the right side is the ModLink OUT port. By directly connecting two ModFX units via the ModLink, audio will pass from the left-most unit to the right-most unit.

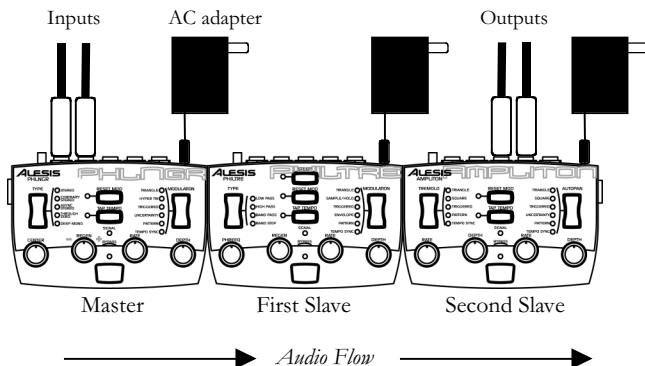

The audio signal flows from left to right. The Master will send its digital audio output to the First Slave, and the First Slave will, in turn, send its output to the Second Slave.

What about the 1/4" jacks on the slave units?

When a unit is a slave to another unit, its audio input jacks are disabled; it will get its audio input digitally from its ModLink port. The output jacks, however, are always active; so an audio output can be tapped from any linked unit, without interrupting the flow to the rest of the chain.

3 Using the Metavox

This section explains the technology of synthesis and vocoding and describes the functions of the Metavox's controls in greater detail.

About Vocoding

The Metavox is a *vocoder*. Vocoder is the result of research into the sound of the human voice, and ways to artificially synthesize voices. One way of understanding it is to think of the Metavox as a synthesizer whose output level and tone are controlled by an audio input, instead of by a keyboard. Usually, but not always, that controlling audio is from a vocal microphone. Speak into the microphone, and the sound of the Metavox's own synthesizer will come on, following the volume of your voice; this is called *envelope following*. The tone and pitch of the incoming signal are used to control multiple band pass filters of the vocoder: higher pitches excite higher band pass filters through which the synth input must pass. **Note that the pitch of the controlling signal does not control the pitch of the synthesizer—it controls the tone only.**

There are two important elements to vocoding in the Metavox:

1. The **SYNTHESIS INPUT**. This can be either the internal single-oscillator synthesizer, with 3 different kinds of waveforms (sawtooth, rectified sawtooth, or square), or a noise generator, or it can be an external instrument plugged into the RIGHT IN. In classic synthesis, this is referred to as the *carrier*.
2. The **CONTROLLER** input. This can be any line-level signal, though it's usually from a microphone preamp. In classic synthesis, this is called the *analysis signal*.

The Metavox listens constantly to the controller input, derives a multiband filter envelope follower setup from it, and applies that setup to the synthesizer. This allows it to mimic the human vocal sounds that make one vowel (like “a”, “e”, “i”, “o”, “u”) sound different from one another.

But human speech also features consonants (“c”, “k”, “s”), fricatives, and plosives. These sounds are crucial for making the “voice” say something understandable. The Metavox's [SIBILANCE] control adds shaped noise to the high frequency bands of the Synthesis filters, so that when a consonant is detected in the Controller signal, there will be a sibilant sound in the vocoded output, making it even more speech-like.

The most basic element of vocoding is amplitude control. The Metavox “listens” to the level of the controller signal, and makes the carrier/synthesis signal as loud or as soft as that input. Every sound has its own “envelope” or dynamic curve; the Metavox uses that envelope to control its output VCA (voltage-controlled amplifier).

The result is a unique signal processing path that puts one sound under the control of another. The creative and commercial possibilities of generating voice-like sounds from either the internal synthesizer or from an external instrument are as varied as the sound of the human voice itself. But vocoding need not stop there. Any sound can be the controller, and any sound can be the synthesizer. You could vocode Jimi Hendrix with the sound of water droplets, for example.

What is Tempo Sync?

In the Metavox, Tempo Sync affects only the frequency modulation (e.g., vibrato) of the internal waveform oscillator.

Sometimes, you'll want the rate of the vibrato or pitch change to match the beat of your music instead of being random. For example, you can set the rate so that the pitch of the SAW wave changes once per measure, or once per quarter note. The TEMPO SYNC feature of the Alesis ModFX series not only lets you set a tempo naturally by tapping on the TAP TEMPO button, it can automatically adjust its speed slightly relative to a "tapped" audio input, after setting the basic speed using the TAP button.

To use Tempo Sync:

Set the Metavox's MODULATION section to TEMPO SYNC mode, as follows:

1. Press the down side of the [MODULATION] rocker switch to select the next modulation type.

You can see the type of effect by the LED lit next to the name—for example, TRIANGLE, SAMPLE/HOLD, TRIGGERED and so on.

2. Keep pressing the rocker switch through all the normal modes until you enter TEMPO SYNC mode, and then advance to the type of modulation you want.

Both the Mod Type and TEMPO SYNC LEDs will be lit. For example, if you press the down side of the rocker switch when you're in PATTERN mode, the Metavox will go to TRIANGLE/TEMPO SYNC mode. At this point, the TAP TEMPO LED will start flashing at the last speed it was set to (or at the default tempo of 120 bpm).

3. Tap the [TAP TEMPO] button several times to set the desired tempo.

The TAP TEMPO LED will flash in time to the beats. As long as the [RATE] control is in the center position, the modulation speed will match the tempo.

4. If the tempo isn't quite right, "tap" a steady, discrete beat on any instrument connected to the input. The internal processor will then synchronize the tapped tempo with the audio input. The processor will make slight alterations to the tempo such that it stays synchronized with the beat of the audio input.

To turn Tempo Sync off:

Simply press the UP side of the [MODULATION] switch repeatedly until the Tempo Sync LED goes off, then select the modulation waveform you want.

The RATE knob is different in Tempo sync mode

In TEMPO SYNC mode, the RATE knob acts as a multiplier to the speed set by TAP TEMPO, so you can't get the tempo to change slightly by adjusting that knob. Note that changes to RATE won't affect the flashing of the TEMPO LED.

Description of Controls

Synthesis Input Switch

The up/down rocker switch beside the Synthesis Input label on the left side of the unit selects the synthesis input, i.e., the internally-generated or external sound that will be vocoded and sent to the OUTPUTS. The LEDs next to the switch light up to indicate the current synthesis input. There are five choices available:

Saw

A standard sawtooth wave is one of the most popular synthesizer waves, with plenty of overtones and a characteristically “buzzy” sound.



Rectified Saw

This is a sawtooth wave, with a little of the “edge” taken off. It’s also an octave lower than the SAW wave at a given PHREEQ setting.



Square

This mode uses an internal square wave for the synthesis input. Square waves are another popular synth waveform, because they have a more rounded low end with more fundamental.

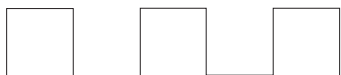

Noise

This mode selects a white noise generator as the sound to be vocoded by the input. Since white noise has all frequencies at once, the vocoder's filters will be most noticeable on this setting.

NOISE will not be affected by the MODULATION controls (RATE, DEPTH, TAP TEMPO etc.) because it isn't a pitched waveform.

Right In = Synth

Use this mode when you want to vocode any external input—a polyphonic synthesizer, guitar, etc. **When [SYNTHESIS INPUT] is set to RIGHT IN = SYNTH, the right input will be the sound that is processed, and the left input (normally a microphone) will be the sound that controls the amplitude and tone of the right input.** In other words, the right input is what gets vocoded, and the left input does the vocoding. See page 19 for the typical hookup.

Phreeq

The [PHREEQ] knob sets the frequency or pitch of the Metavox's internal waveform oscillator, so it has effect only when the [SYNTHESIS INPUT] switch is set to SAW, RECTIFIED SAW, or SQUARE. At full-counter clockwise rotation, the frequency is very low (subsonic). At full clockwise, the oscillator frequency is in the upper range of a typical keyboard.

Siblance

[SIBILANCE] adds “consonant” sound to the output of the Metavox if there isn't enough high-frequency information in the synthesis input (the carrier) itself to allow the higher band-pass filter envelopes to mimic the effect of consonants in human speech. Technically, [SIBILANCE] mixes in noise into the high frequency bands of the Synthesis filters, so when a high-frequency consonant, fricative, or plosive sound appears in the controlling input, there will be something for the higher bandpass filters to pass along to the output in response. If the [SYNTHESIS INPUT] is set to NOISE, the carrier signal already has enough high-frequency content to mimic consonants.

Modulation switch

The up/down rocker switch under the MODULATION label on the right side of the Metavox selects the waveform that will be used to modulate the pitch of the internal sawtooth or square wave oscillator only. This control has no effect if the [SYNTHESIS INPUT] switch is set to NOISE or RIGHT IN = SYNTH. There are five shapes available, as indicated by the LEDs next to the switch:

Triangle

This mode selects a triangle wave for the oscillator's modulation. Use TRIANGLE when you want the smooth up-and-down cycle of traditional vibrato.

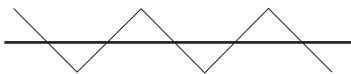

Sample/Hold

This mode selects a sample and hold wave for the oscillator's modulation. The pitch of the wave will jump randomly from pitch to pitch, holding a pitch until it's time for the next one.

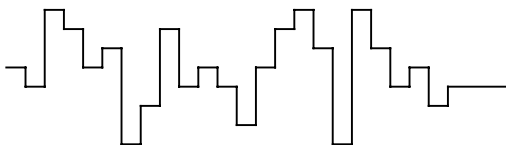

Triggered

The triggered mode selects a triggered envelope for the oscillator's modulation. When a trigger occurs, the modulation will cause a spike in the oscillator frequency. A trigger is any sudden increase in the input audio level. So, if you play a heavy accent on a note, the pitch will start high, the quickly slide down. Pressing the [RESET MOD] button will also cause a trigger. Note that since there's no repeating waveform in Triggered mode, the [TAP TEMPO] features have no effect. [RATE] will affect the decay time of the envelope.

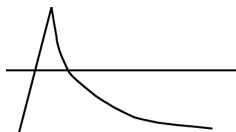

Uncertainty

This mode generates a continually varying waveform for the oscillator's modulation; it's similar to Sample and Hold but the pitch will glide from note to note, instead of jump.

Pattern

This mode randomly generates a 16-step pattern for the oscillator's modulation and repeats it over and over. In some ways, it sounds like a mix of SAMPLE AND HOLD and UNCERTAINTY, since Pattern mode sometimes makes the level jump quickly from step to step, while other levels "glide" from step to step. Another important difference is that the pattern will repeat regularly until you change the pattern.



- Press the [RESET MOD] button to generate a new 16-step pattern.
- Try using the [RATE] knob, or the TEMPO SYNC/TAP TEMPO features, to make the steps of the pattern play in sync with your music. Keep in mind that the pattern has 16 steps per 4 beats, so adjust the RATE knob accordingly.

RATE in Pattern mode

You can think of Pattern mode as being 4x the rate of Sample and Hold or Uncertainty. In Tempo Sync mode, turn the [RATE] knob full clockwise (1/4 speed) to get one step per beat, the same as Sample and Hold at a 12 o'clock setting of [RATE].

3 Using the Metavox

Depth

The [DEPTH] knob controls how much pitch modulation (vibrato) of the above LFO waves and patterns will be applied to the internal waveform oscillator's SAW, RECTIFIED SAW, or SQUARE waves.

Rate

The [RATE] knob changes the speed of the pitch modulation of **the internal waveform synthesizer only**. In normal modulation modes (TEMPO SYNC LED off), turning the [RATE] knob alters the rate continuously from very slow to very fast. Turn the knob clockwise for a faster vibrato effect, counter-clockwise for a slow pitch change.

Rate knob operation in TEMPO SYNC mode

When the Metavox is in TEMPO SYNC mode, the fundamental modulation speed is set by the TAP TEMPO function, and the rate knob can be used to adjust that rate to an even fraction or multiple of the current tempo:

- With the knob indicator in the 12 o'clock position, the mod rate will be the same as tempo (i.e., quarter note).
- Turn the knob to the left to set the mod rate at a half of the tempo (i.e., one cycle per half note), then a quarter of the tempo (once per measure).
- Turn the knob to the right to set the modulation to twice the tempo (eighth notes), or four times the tempo (sixteenth notes).

The diagram below shows where you can set the [RATE] knob to modulate the internal oscillator at different multiples of the tempo during TEMPO SYNC mode.

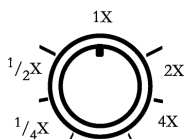

Depth = Mod Wheel

Think of the [DEPTH] control as being like the Mod Wheel on a synthesizer, applying an LFO to the pitch of the internal oscillator, giving it more or less vibrato. The [RATE] controls the speed of the LFO, and the [MODULATION] switch determines the waveform of the LFO.

See the description of TAP TEMPO for important tips on using this feature.

Reset Mod

Press this button to reset the modulation as follows:

- In TRIANGLE and SAMPLE/HOLD modes, press [RESET MOD] to start the wave from the beginning of its phase.

In Triangle, RESET starts the mod from the bottom of the wave.

- In TRIGGERED mode press this button to generate a trigger for the modulation (sending the equivalent of a pitch envelope to the oscillator).
- In PATTERN mode press this button to generate a new 16-step pattern.

Tap Tempo

This button affects the speed of the effect whenever the [MODULATION] switch is set to TEMPO SYNC mode. In that mode, you can tap this button along with the music to set a new tempo. The Tap Tempo light will flash at the current tempo.

Tap Tempo technique

For a reliable tempo setting, make several taps in a row at a consistent speed, especially if you're changing the tempo drastically. Watch the flashing of the light to see the current tempo of the Metavox.

Adjusting tempo with audio input

After the basic tempo has been set using the [TAP TEMPO] button, it is possible to make small adjustments to the tempo via the audio input. You do this by “tapping” on the instrument (playing sharp chords, or beats, without sustain or notes inbetween) at almost the same speed as the Metavox's tempo LED. The Metavox can derive a beat from a complex musical input, as long as it is reasonably close to the original “tapped” tempo. The tempo can adjust up or down about 15% from the original tempo tapped in.

How Tap Tempo works with Tempo Sync and the Rate knob

When TEMPO SYNC mode is enabled, the rate of the modulation will be based on the tempo currently being flashed, multiplied by the position of its [RATE] knob: when it's in the middle position (around “12 o'clock”), the speed of the triangle, square, pattern etc. wave will be the same as the tempo. See the earlier descriptions of the [RATE] knob and Tempo Sync for more information.

To get fast modulations...

it isn't necessary to tap at a high speed if you want the effect to modulate at eighth or sixteenth notes. Just tap on the quarter-note beat, then turn the [RATE] knob to the right to double or quadruple the speed made by Tap Tempo.

Bypass

This button sends the signal directly from the input to the output without any effect. Press [BYPASS] to check the sound of the source without any effect from the Metavox. When the red BYPASS LED is lit, no vocoding takes place. The Bypass function can also be activated by the foot switch.

Since the Metavox is a digital effect, signal always passes through the digital A/D–D/A conversion process, so that digital signal will flow through to other effects in a ModLink chain even when [BYPASS] is on. So, unlike old analog effects, this is not a “hardwire” bypass switch—the Metavox must be powered on to pass signal through, even in bypass mode. Similarly, the [TRIM] control is always active, since it’s an analog control regulating the level feeding the analog-to-digital converters.

Using the Foot Switch

If you need to bypass the effect totally but your hands aren’t free, simply connect any momentary footswitch (such as those used for keyboard sustain pedals, either NC normally closed or NO normally open) to the [FOOT SWITCH] jack on the rear panel. The footswitch will turn the BYPASS LED on and off.

4 Sample Settings

While there's nothing like discovering new sounds for yourself, we thought it would be a good idea to provide some sample settings of the Metavox to help get you started. Simply set the knobs on your Metavox so they're at the positions shown, and press the rocker switches so each effect is in the mode shown by the LEDs. Feel free to modify these any way you want to suit your particular playing style.

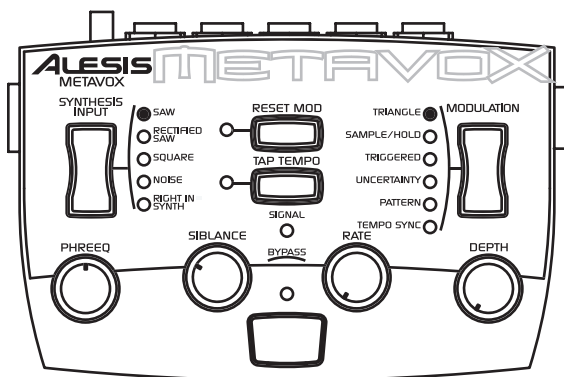

Deep Robot

A classic robo-voice, modulated by an external microphone. Try it with other synthesis inputs as well.

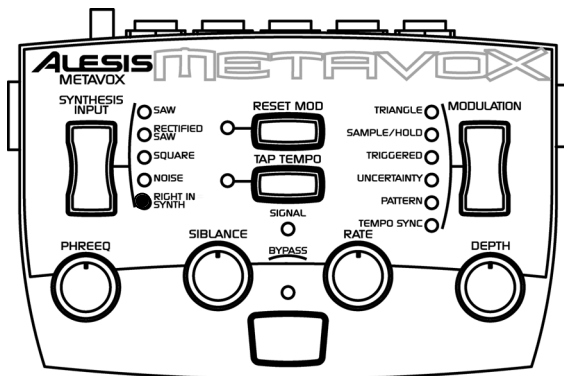

Standard external vocoding

None of the controls matter except [SIBLANCE], when [SYNTHESIS INPUT] is set to RIGHT IN = SYNTH.

4 Sample Settings

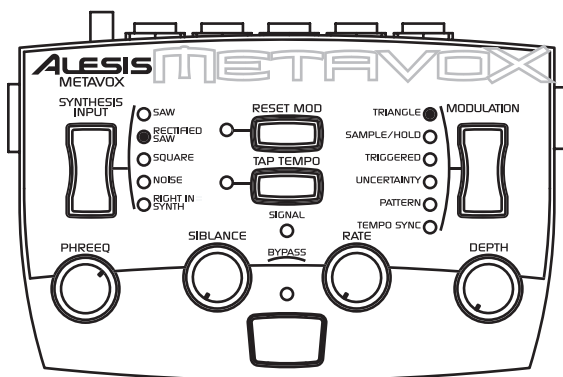

Battle Star

A deeper sort of outer-space voice; try adjusting PHREEQ to get the precise effect you want.

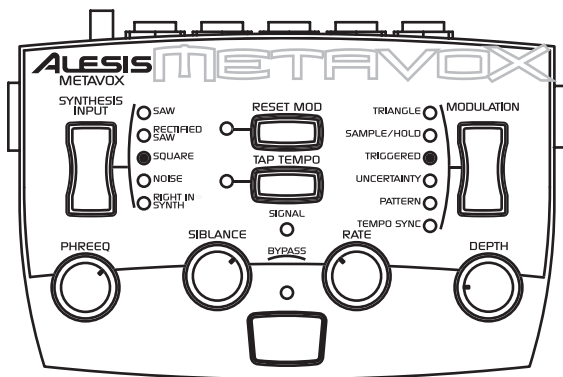

Odd Inflection

This patch uses the TRIGGERED waveform to “swoop” the square wave every time the controlling voice or instrument has a sudden increase in gain.

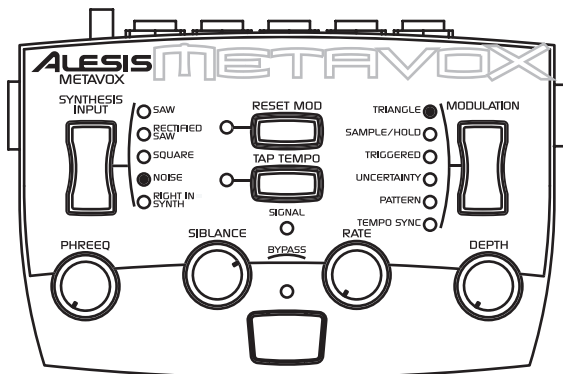

Evil whisper

Using NOISE as the source lets you hear the vocoding effect to its fullest.

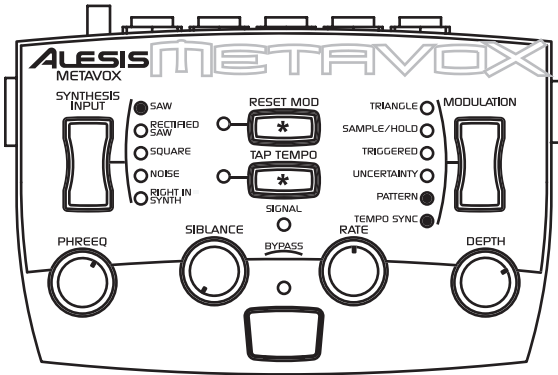

Vocomotion

This setting has a rhythm to it, which you must set using the TAP TEMPO buttons. If you don't like the pattern, press RESET MOD until you find one you like.

As a variation, try SAMPLE/HOLD as the source, with the RATE set to full.

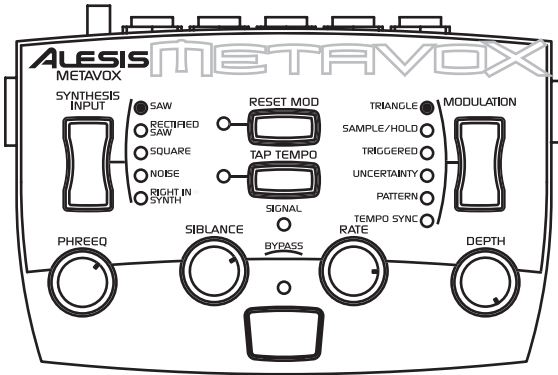

Mod Vox

High-frequency modulation of the Saw wave by a Triangle wave changes the timbre of the carrier wave in this setting.

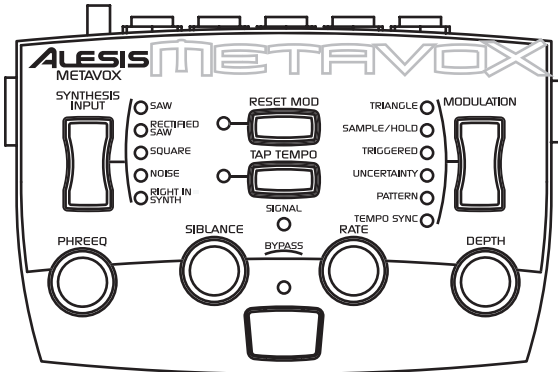

Blank

Experiment to find your favorite setting and mark it for recall here.

Photocopy the next page if you need more settings.

Blank Settings Templates

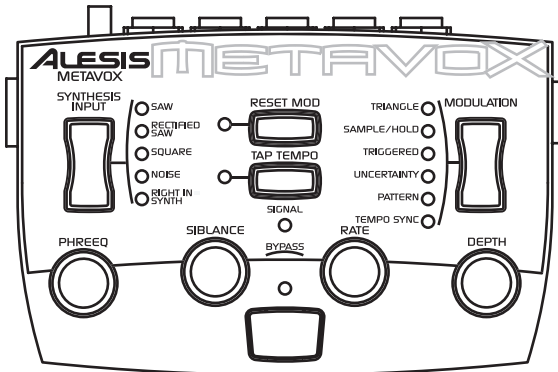
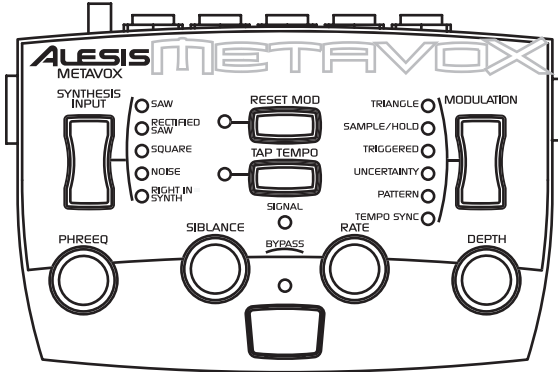
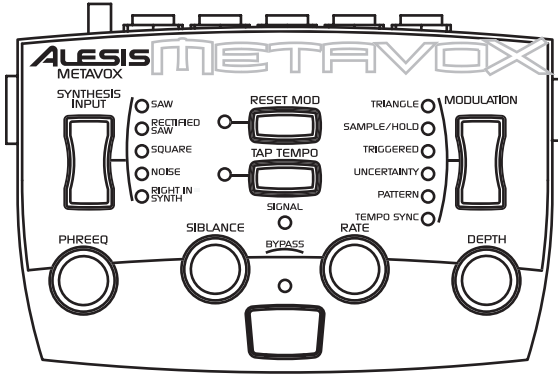

5 Troubleshooting

Troubleshooting Index

If you experience problems while operating your Metavox, please use the following table to locate possible causes and solutions before contacting Alesis Product Support for assistance.

| Symptoms | Cause | Solution |
|--|---|--|
| No audio outputs. | No input audio(SIGNAL LED doesn't flash). PHREEQ is too low. Bad cables. Destination is turned down. | Test with a known good input. Raise PHREEQ to "2 o'clock" or higher. Replace the cables. Check the connections and the level of the mixer or amp that the Metavox is connected to. |
| | Input Trim knob is turned down Input cables are connected to a linked unit Power is not connected Not enough level to LEFT INPUT when vocoding | Adjust the knob to the proper level. Connect the input cables to the Master of the link chain Go take a walk Increase output level of mic preamp; make sure mic is switched on etc. |
| Can't hear source instrument in mix, only single-note oscillator | SYNTHESIS INPUT isn't set to RIGHT IN = SYNTH | Set SYNTHESIS INPUT to RIGHT IN; you will hear source instrument when LEFT IN receives audio input |
| [TAP TEMPO] button is not working | Modulation isn't in Tempo Sync mode | Select Tempo Sync mode |
| ModLinked units are not working properly | Power dropout to one of the units in the chain | Plug in a power supply to every unit in a chain. |
| Distorted sound | Input level too high (SIGNAL LED on front panel flashes red) RATE set at a high speed, to a point where it sounds like ring modulation | Turn down the source, or the TRIM control on the Metavox's back panel. Turn down the RATE knob (below about "3 o'clock") |
| Distortion when you leave TEMPO SYNC mode | [RATE] knob is set high to get 4x the Tap Tempo rate; when you go back to a normal mode, the RATE jumps up high and sounds like distortion | Reduce the [RATE] setting |

| Symptoms | Cause | Solution |
|--------------------------|---|---|
| Buzz or hum from outputs | Audio cables are crossing a power cable or a power adapter. | Make sure that the Metavox and its audio cables are kept away from power cables and wall warts. Don't wrap cable in tight bundles. |
| | Bad cables | Replace the cables |
| | Problem with the source | Try bypassing the Metavox by connecting the input cables to the output cables and see if the problem remains. |
| AC hum | Ground loop | Place all equipment in the studio on a common ground (see next page) |

Avoiding ground loop noise

In today's studio, where it seems every piece of equipment has its own computer chip inside, there are many opportunities for ground loop problems to occur. These show up as hums, buzzes or sometimes radio reception and can occur if a piece of equipment "sees" two or more different paths to ground. While there are methods to virtually eliminate ground loops and stray radio frequency interference, most of the professional methods are expensive and involve installing a separate power source just for the sound system. Alternatively, here are some helpful hints that professional studio installers use to keep those stray hums and buzzes to a minimum.

KEEP ALL ELECTRONICS OF THE SOUND SYSTEM ON THE SAME AC ELECTRICAL CIRCUIT.

Most stray hums and buzzes happen as a result of different parts of the sound system being plugged into outlets of different AC circuits. If any noise generating devices such as air conditioners, refrigerators, neon lights, etc., are already plugged into one of these circuits, you then have a perfect condition for stray buzzes. Since most electronic devices of a sound system don't require a lot of current (except for power amplifiers), it's usually safe to run a multi-outlet box or two from a SINGLE wall outlet and plug in all of the components of your system there.

KEEP AUDIO WIRING AS FAR AWAY FROM AC WIRING AS POSSIBLE.

Many hums come from audio cabling being too near AC wiring. If a hum occurs, try moving the audio wiring around to see if the hum ceases or diminishes. If it's not possible to separate the audio and AC wiring in some instances, make sure that the audio wires don't run parallel to any AC wire (they should only cross at right angles, if possible).

TO ELIMINATE HUM IF THE ABOVE HAS FAILED:

1. Disconnect the power from all outboard devices and tape machines except for the Metavox, the mixer and control room monitor power amp.
2. Plug in each tape machine and outboard effects device one at a time. If possible, flip the polarity of the plug of each device (turn it around in the socket) until the quietest position is found.
3. Make sure that all of the audio cables are in good working order. Cables with a detached ground wire will cause a very loud hum!!

4. Keep all cables as short as possible, especially in unbalanced circuits.

If the basic experiments don't uncover the source of the problem, consult your dealer or technician trained in proper studio grounding techniques. In some cases, a "star grounding" scheme must be used, with the mixer at the center of the star providing the shield ground on telescoping shields, which do NOT connect to the chassis ground of other equipment in the system.

Line conditioners and spike protectors

Although the Metavox is designed to tolerate typical voltage variations, in today's world the voltage coming from the AC line may contain spikes or transients. These can cause audible noises, and they can stress your gear and, over time, possibly cause a failure. There are three main ways to protect against this, listed in ascending order of cost and complexity:

- **Line spike/surge protectors.** Relatively inexpensive, these are designed to protect against strong surges and spikes, acting somewhat like fuses in that they need to be replaced if they've been hit by an extremely strong spike.
- **Line filters.** These generally combine spike/surge protection with filters that remove some line noise (dimmer hash, transients from other appliances, etc.). A good example is the Isobar™ series from Tripp Lite.
- **Uninterruptible power supply (UPS).** This is the most sophisticated option. A UPS provides power even if the AC power line fails completely. Intended for computer applications, a UPS allows you to complete an orderly shutdown of a computer system in the event of a power outage. In addition, the isolation it provides from the power line minimizes all forms of interference—spikes, noise, etc.

Care and Maintenance

Cleaning

Disconnect the AC cord, then use a damp cloth to clean the Metavox's metal and plastic surfaces. For heavy dirt, use a non-abrasive household cleaner such as Formula 409™ or Fantastik™. **DO NOT SPRAY THE CLEANER DIRECTLY ONTO THE FRONT OF THE UNIT AS IT MAY DESTROY THE LUBRICANTS USED IN THE SWITCHES AND CONTROLS!** Spray onto a cloth, then use cloth to clean the unit.

Refer all servicing to Alesis

We believe that the Metavox is one of the best signal processors that can be made using current technology, and should provide years of trouble-free use. However, should problems occur, **DO NOT** attempt to service the unit yourself unless you have training and experience. Service on this product should be performed only by qualified technicians. **NO USER-SERVICEABLE PARTS INSIDE.**

Obtaining repair service

Before contacting Alesis, check over all your connections, and make sure you've read the manual.

Customers in the USA and Canada:

If the problem persists, contact Alesis and request the Product Support department. Make sure you have the unit's serial number with you. Talk the problem over with one of our technicians; if necessary, you will be given a return order (RO) number and instructions on how to return the unit. All units must be shipped prepaid and COD shipments will not be accepted.

For prompt service, indicate the RO number on the shipping label. **Units without an RO will not be accepted.** If you do not have the original packing, ship the unit in a sturdy carton, with shock-absorbing materials such as Styrofoam pellets (the kind without CFCs, please) or "bubble-pack" surrounding the unit. Shipping damage caused by inadequate packing is not covered by the Alesis warranty.

Tape a note to the top of the unit describing the problem, include your name and a phone number where Alesis can contact you if necessary, as well as instructions on where you want the product returned. Alesis will pay for standard one-way shipping back to you on any repair covered under the terms of this warranty. Field repairs are not authorized during the warranty period, and repair attempts by unqualified personnel may invalidate the warranty.

Customers outside the USA and Canada:

Contact your local Alesis distributor for any warranty assistance. The Alesis Limited Warranty applies only to products sold to users in the USA and Canada. Customers outside of the USA and Canada are not covered by this Limited Warranty and may or may not be covered by an independent distributor warranty in the country of sale. Do not return products to the factory unless you have been given specific instructions to do so.

Specifications

Audio Input

| | |
|-----------------------------|---|
| Input Connectors: | 2 unbalanced 1/4" jacks |
| Maximum Input Level: | +10 dBV |
| Nominal Level: | -10 dBV (adjustable, left input) -20 dBV (right input) |
| Input Impedance: | 470k Ω |
| Input Converter Resolution: | 24-bit, 48 kHz sampling |

All measurements done over a 22Hz – 22kHz range with a 1kHz sine wave at -1dBFS input. Impedances are measured at 1kHz.

Audio Output

| | |
|------------------------------|-------------------------|
| Output Connectors: | 2 unbalanced 1/4" jacks |
| Maximum Output Level: | +9 dBV |
| Output Impedance: | 500 Ω |
| Output Converter Resolution: | 24-bit, 48 kHz sampling |

Audio Performance

(Analog In to Analog Out)

| | |
|--------------------------|------------------------------|
| Signal To Noise Ratio: | >100 dB A-weighted |
| THD+N: | < 0.005% |
| Frequency Response: | \pm 1dB from 22Hz to 22kHz |
| Internal DSP Resolution: | 28-bit |
| Power Consumption: | 7 Watts max (9VAC Alesis P3) |

Mechanical

| | |
|---------|--|
| Size: | 2.1" H x 5.8" W x 3.9" D (53mm H x 148mm W x 98mm D) |
| Weight: | 12.6oz. (357 g) |

6 Specifications

This page intentionally left blank.

Index

- amplifier, **22**
- Aux Send/Return, 21
- BYPASS**, 16, 34
 - with foot switch, 34
- cables, **23**
- Cleaning, 43
- CONTROLLER**, 25
- DEPTH**, 16, 32
- digital converters, 34, 45
- DIRECT OUT**, 18
- DSP, 45
- envelope, 25
- external source, 4, 19
- FOOT SWITCH**, 16, 34
- Ground Loop, 41
- grounding, 7
- Group Sends, 21
- Hums and buzzes, 41
- INPUTS**, **15**
- INPUTS and OUTPUTS**, 16
- INSERT**
 - as Direct Out for mic, 18
- Insert Cables, 20
- levels, 15, 16, **23**
- mic preamp, 18
- mic transformer, 18
- microphone, 15, 18, 19, 25
- Mod wheel, 32
- ModFX, 24
- ModLink**, 16, 24
- MODULATION**, 30
- MODULATION switch**, 16
- Noise, 29
- oscillator, 4, 28
- OUTPUTS**, **15**
 - on ModLink slave units, **24**
- Pattern, 31
- PHREEQ**, 16, 29
- pitch**
 - not changed by incoming signal, 25
- POWER**, 15
 - power adapter, 17
- Power cable, 7
- Rack mounting, 17
- RATE**, 16, 32
- Rectified Saw, 28
- repair, 44
- Reset Mod**, 16, 33
 - in Triggered Mode, 30
- RIGHT IN = SYNTH**, 19, 29
- Safety, 7
- Sample/Hold, 30
- Saw, 28
- SIBILANCE**, 16, 25, 29
- SIGNAL LED**, **15**, 16, 19, 23
- Square, 28
- SYNTHESIS INPUT**, 15, 16, 25, 28
- synthesizer, 15, 18, 25
- Tap Tempo**, 16, 27, 33
- Tempo Sync, **27**
 - effect on RATE knob, 32
- transformers, **23**
- Triangle, 30
- Triggered, 30
 - by RESET MOD, 33
- TRIM**, **15**, 16, **19**
 - active in bypass mode, 34
- Uncertainty, 31
- vocoder, 4, 25
 - and synthesizers, 18
- voice modulation, 15
- XLR, 23

Warranty / Contact Alesis

Alesis Limited Warranty

ALESIS CORPORATION ("ALESIS") warrants this product to be free of defects in material and workmanship for a period of one (1) year for parts and for a period of one (1) year for labor from the date of original retail purchase. This warranty is enforceable only by the original retail purchaser and cannot be transferred or assigned. For the most effective service, the purchaser should register the purchase on the ALESIS website at <http://www.alesis.com/support/warranty.htm>. During the warranty period ALESIS shall, at its sole and absolute option, either repair or replace free of charge any product that proves to be defective on inspection by ALESIS or its authorized service representative. In all cases disputes concerning this warranty shall be resolved as prescribed by law.

To obtain warranty service, the purchaser must first call or write ALESIS at the address and telephone number available on the Alesis Website to obtain a Return Authorization Number and instructions concerning where to return the unit for service. All inquiries must be accompanied by a description of the problem. All authorized returns must be sent to ALESIS or an authorized ALESIS repair facility postage prepaid, insured and properly packaged. Proof of purchase must be presented in the form of a bill of sale, canceled check or some other positive proof that the product is within the warranty period. ALESIS reserves the right to update any unit returned for repair. ALESIS reserves the right to change or improve design of the product at any time without prior notice.

This warranty does not cover claims for damage due to abuse, neglect, alteration or attempted repair by unauthorized personnel, and is limited to failures arising during normal use that are due to defects in material or workmanship in the product.

THE ABOVE WARRANTIES ARE IN LIEU OF ANY OTHER WARRANTIES OR REPRESENTATIONS WHETHER EXPRESS OR IMPLIED OR OTHERWISE, WITH RESPECT TO THE PRODUCT, AND SPECIFICALLY EXCLUDE ANY IMPLIED WARRANTIES OF FITNESS FOR A PARTICULAR PURPOSE OR MERCHANTABILITY OR OTHER IMPLIED WARRANTIES. Some states do not allow limitations on how long an implied warranty lasts, so the above limitation may not apply to you. IN NO EVENT WILL ALESIS BE LIABLE FOR INCIDENTAL, CONSEQUENTIAL, INDIRECT OR OTHER DAMAGES RESULTING FROM THE BREACH OF ANY EXPRESS OR IMPLIED WARRANTY, INCLUDING, AMONG OTHER THINGS, DAMAGE TO PROPERTY, DAMAGE BASED ON INCONVENIENCE OR ON LOSS OF USE OF THE PRODUCT, AND, TO THE EXTENT PERMITTED BY LAW, DAMAGES FOR PERSONAL INJURY. Some states do not allow the exclusion or limitation of incidental or consequential damages, so the above limitation or exclusion may not apply to you.

THIS CONTRACT SHALL BE GOVERNED BY THE INTERNAL LAWS OF THE STATE OF CALIFORNIA WITHOUT REFERENCE TO CONFLICTS OF LAWS. This warranty gives you specific legal rights, and you may also have other rights required by law which vary from state to state.

This warranty only applies to products sold to purchasers in the United States of America or Canada. The terms of this warranty and any obligations of Alesis under this warranty shall apply only within the country of sale. Without limiting the foregoing, repairs under this warranty shall be made only by a duly authorized Alesis service representative in the country of sale. For warranty information in all other countries please refer to your local distributor.

For more effective service and product update notices, please register your Metavox online at:

<http://www.alesis.com/support/warranty.htm>

Alesis Contact Information

Alesis Studio Electronics
Los Angeles, CA USA

E-mail: support@alesis.com
Website: <http://www.alesis.com>

Alesis Metavox Reference Manual
Revision 1.0 by Alex Souppa & Dan Tinen

Copyright 2002, Alesis. All rights reserved
Reproduction in whole or in part is prohibited. Specifications
subject to change without notice. All trademarks are the property
of their respective holders.

7-51-0117-A
8/2002