

M1 ACTIVE

BIAMPLIFIED REFERENCE MONITOR



**REFERENCE
MANUAL**

ALESIS

M1 ACTIVE

BIAMPLIFIED REFERENCE MONITOR

REFERENCE MANUAL

1998

Introduction

Thank you for purchasing the Alesis M1 Active Bi-amplified Reference Monitor. To take full advantage of the M1 Active's operation, and to enjoy long and trouble-free use, please read this user's manual carefully. We value any comments you may have about this monitor system, this manual, your Alesis dealer and about our factory service. Please take a minute now to fill out your warranty card and tell us what you think.

How to use this manual

This manual is divided into the following sections describing the various features of the M1 Active. Though we recommend you take time to read through the entire manual once carefully, those having general knowledge about monitors should use the table of contents to reference specific functions.

Chapter 1: About the M1 Active. Engineering specifications and reasons why nearfield monitors have become so popular.

Chapter 2: Speaker Installation. This chapter explains how to connect the M1 Actives to a mixer or other line-level source and discusses proper speaker placement for stereo operation.

Chapter 3: Surround Sound. If you are using the M1 Active speakers in a multichannel surround sound setup, you'll find helpful setup and operation information here.

Chapter 4: Troubleshooting. This chapter contains troubleshooting tips and service information should problems occur.



When something important appears in the manual, an icon (like the one on the left) will appear in the left margin. This symbol indicates that this information is vital when operating the M1 Actives.

CONTENTS

Important Safety Instructions	3
Safety symbols used in this product	3
Please follow these precautions when using this product	3
Instructions de Sécurité Importantes	4
Symboles utilisés dans ce produit	4
Beim Benutzen dieses Produktes beachten Sie bitte die folgenden Sicherheitshinweise:.....	5
Information to the User for Class A Digital Device (FCC Part 15, Class A)	7
About the M1 Active	9
Unpacking and Inspection	9
Inside your new speakers	10
About Nearfield monitoring	14
Speaker Installation	15
Avoiding reflections in the studio	15
Stereo nearfield placement of the M1 Active	17
Connections	22
Setting the Input Level control	24
Surround Sound	26
About surround sound	26
Center speakers in music mixes	26
Placement of the center M1 Active speaker in the studio.....	27
Placement of rear surrounds.....	28
Mixing for discrete six channel reproduction: matched vs. specialized speakers.....	31
Troubleshooting	33
Troubleshooting Index	33
Maintenance.....	33
Specifications	36
Enclosure	36
Transducers	36
Crossover section.....	37
Amplifier Section.....	37
Acoustic Section	37
General	37
Index	38
Alesis Extended Warranty	39

IMPORTANT SAFETY INSTRUCTIONS

Safety symbols used in this product



This symbol alerts the user that there are important operating and maintenance instructions in the literature accompanying this unit.

Please follow these precautions when using this product:



1. Read these instructions.

2. Keep these instructions.
3. Heed all warnings.
4. Follow all instructions.
5. Do not use this apparatus near water.
6. Clean only with a damp cloth. Do not spray any liquid cleaner onto the speakers or rear panel, as this may damage the speakers, controls or cause a dangerous condition.
7. Install in accordance with the manufacturer's instructions.
8. Do not install near any heat sources such as radiators, heat registers, stoves, or other apparatus (including amplifiers) that produce heat.



9. Do not defeat the safety purpose of the polarized or grounding-type plug. A polarized plug has two blades with one wider than the other. A grounding-type plug has two blades and a third grounding prong. The wide blade or the third prong are provided for your safety. When the provided plug does not fit into your outlet, consult an electrician for replacement of the obsolete outlet.
10. Protect the power cord from being walked on or pinched, particularly at plugs, convenience receptacles, and the point where they exit from the apparatus.
11. Use only attachments or accessories specified by the manufacturer.



12. Use only with a cart, stand, bracket, rack, or table designed for use with professional audio or music equipment. In any installation, make sure that injury or damage will not result from cables pulling on the apparatus and its mounting. If a cart is used, use caution when moving the cart/apparatus combination to avoid injury from tip-over.
13. Unplug this apparatus during lightning storms or when unused for long periods of time.



14. Refer all servicing to qualified service personnel. Servicing is required when the apparatus has been damaged in any way, such as when the power-supply cord or plug is damaged, liquid has been spilled or objects have fallen into the apparatus, the apparatus has been exposed to rain or moisture, does not operate normally, or has been dropped.
15. This product may be capable of producing sound levels that could cause permanent hearing loss. Do not operate for a long period of time at a high volume level or at a level that is uncomfortable. If you experience any hearing loss or ringing in the ears, you should consult an audiologist.

Instructions de Sécurité Importantes

Symboles utilisés dans ce produit



Ce symbole alerte l'utilisateur qu'il existe des instructions de fonctionnement et de maintenance dans la documentation jointe avec ce produit.



Ce symbole avertit l'utilisateur de la présence d'une tension non isolée à l'intérieur de l'appareil pouvant engendrer des chocs électriques.

Veillez suivre ces précautions lors de l'utilisation de l'appareil:

1. Lisez ces instructions.
2. Gardez ces instructions.
3. Tenez compte de tous les avertissements.
4. Suivez toutes les instructions.
5. N'utilisez pas cet appareil à proximité de l'eau.
6. Ne nettoyez qu'avec un chiffon humide. Ne pas vaporiser de liquide nettoyant sur l'appareil, cela pourrait abîmer les contrôles de la face avant ou engendrer des conditions dangereuses.
7. Installez selon les recommandations du constructeur.
8. Ne pas installer à proximité de sources de chaleur comme radiateurs, cuisinière ou autres appareils (don't les amplificateurs) produisant de la chaleur.
9. Ne pas enlever la prise de terre du cordon secteur. Une prise murale avec terre deux broches et une troisième reliée à la terre. Cette dernière est présente pour

- votre sécurité. Si le cordon secteur ne rentre pas dans la prise de courant, demandez à un électricien qualifié de remplacer la prise.
10. Evitez de marcher sur le cordon secteur ou de le pincer, en particulier au niveau de la prise, et aux endroits où il sort de l'appareil.
 11. N'utilisez que des accessoires spécifiés par le constructeur.
 12. N'utilisez qu'avec un stand, rack ou table conçus pour l'utilisation d'audio professionnel ou instruments de musique. Dans toute installation, veillez de ne rien endommager à cause de câbles qui tirent sur des appareils et leur support.
 13. Débranchez l'appareil lors d'un orage ou lorsqu'il n'est pas utilisé pendant longtemps.
 14. Faites réparer par un personnel qualifié. Une réparation est nécessaire lorsque l'appareil a été endommagé de quelque sorte que ce soit, par exemple lorsque le cordon secteur ou la prise sont endommagés, si du liquide a coulé ou des objets se sont introduits dans l'appareil, si celui-ci a été exposé à la pluie ou à l'humidité, ne fonctionne pas normalement ou est tombé.
 15. Cet appareil produit de la chaleur en fonctionnement normal. Si cet appareil est utilisé dans un rack, veillez à sa bonne ventilation lors de son utilisation. Ne pas faire fonctionner dans un rack fermé. S'il y a d'autres appareils dans le rack générant beaucoup de chaleur, éloignez les. Ne pas intercaler cet appareil entre deux appareils produisant beaucoup de chaleur.
 16. Ce produit, utilisé avec un amplificateur et un casque ou des enceintes, est capable de produire des niveaux sonores pouvant engendrer une perte permanente de l'ouïe. Ne l'utilisez pas pendant longtemps à un niveau sonore élevé ou à un niveau non confortable. Si vous remarquez une perte de l'ouïe ou un bourdonnement dans les oreilles, consultez un spécialiste.

Beim Benutzen dieses Produktes beachten Sie bitte die folgenden Sicherheitshinweise:

1. Lesen Sie die Hinweise.
2. Halten Sie sich an die Anleitung.
3. Beachten Sie alle Warnungen.
4. Beachten Sie alle Hinweise.
5. Bringen Sie das Gerät nie mit Wasser in Berührung.
6. Verwenden Sie zur Reinigung nur ein weiches Tuch. Sprühen Sie keine flüssiger Reiniger auf die Oberfläche, dies könnte zur Beschädigung der Vorderseite führen und auch weitere Schäden verursachen.
7. Halten Sie sich beim Aufbau des Gerätes an die Angaben des Herstellers.
8. Stellen Sie das Gerät nicht in der Nähe von Heizkörpern, Heizungsklappen oder anderen Wärmequellen (einschließlich Verstärkern) auf.
9. Verlegen Sie das Netzkabel des Gerätes niemals so, daß man darüber stolpern kann oder daß es gequetscht wird.
10. Benutzen Sie nur das vom Hersteller empfohlene Zubehör.
11. Verwenden Sie ausschließlich Wagen, Ständer, Racks oder Tische, die speziell für professionelle Audio- und Musikinstrumente geeignet sind. Achten Sie immer darauf, daß die jeweiligen Geräte sicher installiert sind, um Schäden und Verletzungen zu vermeiden. Wenn Sie einen Rollwagen benutzen, achten Sie darauf, das dieser nicht umkippt, um Verletzungen auszuschließen.
12. Ziehen Sie während eines Gewitters oder wenn Sie das Gerät über einen längeren Zeitraum nicht benutzen den Netzstecker aus der Steckdose.

13. Die Wartung sollte nur durch qualifiziertes Fachpersonal erfolgen. Die Wartung wird notwendig, wenn das Gerät beschädigt wurde oder aber das Stromkabel oder der Stecker, Gegenstände oder Flüssigkeit in das Gerät gelangt sind, das Gerät dem Regen oder Feuchtigkeit ausgesetzt war und deshalb nicht mehr normal arbeitet oder heruntergefallen ist.
14. Bei normalem Betrieb des Gerätes kommt es zu Wärmeentwicklungen. Wenn Sie das Gerät in einem Rack eingebaut haben, sollte während des Betriebes die Zufuhr von Kühlluft stets gewährleistet sein. Arbeiten Sie nie bei geschlossenem Rack. Bei mehreren Rackgeräten sollten diese mit einem geringen abstand voneinander eingebaut werden. Stapeln Sie dieses Gerät nicht zwischen Geräten mit hoher Wärmeentwicklung.
15. Dieses Produkt kann in Verbindung mit einem Verstärker und Kopfhörern oder Lautsprechern Lautstärkepegel erzeugen, die anhaltende Gehörschäden verursachen. Betreiben Sie es nicht über längere Zeit mit hoher Lautstärke oder einem Pegel, der Ihnen unangenehm ist. Wenn Sie ein Nachlassen des Gehörs oder ein Klingeln in den Ohren feststellen, sollten Sie einen Ohrenarzt aufsuchen.

Information to the User for Class A Digital Device (FCC Part 15, Class A)

This equipment has been tested and found to comply with the limits for a class A digital device pursuant to Part 15 of the FCC Rules. These limits are designed to provide reasonable protection against harmful interference when the equipment is operated in a commercial environment. This equipment generates, uses and can radiate radio frequency energy and, if not installed and used in accordance with the instructions, may cause interference to radio communications. Operation of this equipment in a residential area is likely to cause interference in which case the user will be required to correct the interference at his own expense.

The user is cautioned that changes and modifications made to the equipment without the approval of manufacturer could void the user's authority to operate this equipment.

Use only shielded and grounded cables with this equipment to ensure compliance with FCC Rules.

Industry Canada (Digital Apparatus) Interference-Causing Equipment Standard ICES-003 Issue 2

This Class A digital apparatus meets all requirements of the Canadian Interference-Causing Equipment Regulations.



DECLARATION OF CONFORMITY

Approvals pending. See enclosed sheet if product was authorized for shipment to the EU.

ABOUT THE M1 ACTIVE

Unpacking and Inspection

Your M1 Active Bi-amplified Reference Monitors were packed carefully at the factory, and the shipping carton was designed to protect the speakers during shipping. Please retain this container in the highly unlikely event that you need to return the speakers for servicing.

The shipping carton should contain the following items:

- This instruction manual
- M1 Actives with the same serial numbers as shown on the shipping cartons
- Two AC power cords (NEMA to CEE type)
- Alesis warranty card
- Two pieces of adhesive-backed non-skid foam



It is important to register your purchase; if you have not already filled out your warranty card and mailed it back to Alesis, please take the time to do so now.

The M1 Actives are designed as mirror-imaged pairs. If you have received a pair where the tweeters are both on the same side, contact your dealer immediately.

Inside your new speakers



If you're in a hurry to get started, skip ahead to Chapter 2, "Speaker Installation", for connection and placement tips.

About powered monitors

The M1 Actives combine a speaker and amplifiers in the same compact cabinet. Powered monitors are growing in popularity over the traditional separate amplifier and speakers for a number of reasons, convenience and ease of hookup being only one of them. You can connect a powered speaker directly to any line-level source (normally, the control room output of a mixer) simply by connecting a patch cord.

Another benefit is improved sound quality. With careful design, the speaker, amplifier and electronic crossover can be optimised for each other. The M1 Actives are *bi-amplified*, meaning that low frequencies and high frequencies are handled not only by separate speakers (the tweeter and the woofer), but by separate amplifiers. A pair of M1 Actives contain a total of four power amplifiers. Because of the increased efficiency of bi-amplification, these are much louder than a single-channel power amplifier of the same wattage feeding a passive crossover, as in other designs. New technology makes it possible to make these high-wattage amplifiers small enough to fit inside the speaker cabinet, with very little weight or size gain.



Since the M1 Actives are self-powered, **DO NOT** connect them to the speaker output of another amplifier (such as a powered mixer or hi-fi receiver). Connect them only to the line-level outputs of such devices (+4 dBu nominal, +24 dBu maximum).

Tone

Tonally, every effort has been made to emulate the accurate studio sound of Alesis' Monitor One but with enhanced low bass and high frequency extension. The nominal frequency response is 50Hz-20KHz ± 2 dB. (See Figure 1) Additionally, the use of electronic crossovers within the critical upper midrange frequencies has reduced phase and time delay anomalies often associated with passive crossovers. By including discrete woofer and tweeter amplifiers and application-specific electronic high and low pass crossover filters in the same enclosure the tonal accuracy of the M1 Active will always remain constant.

About the drivers

The M1 Active's 6.5" woofer cone is made of proprietary non-woven carbon fiber. This material is 25% lighter than polypropylene with twice the stiffness for quicker transient response in the low-to-midbass region and vastly improved midrange intelligibility (over polypropylene at 1500 Hz). The non-woven carbon fiber cone, along with the closed cell synthetic rubber surround, are both nearly impervious to

ozone, direct sunlight, heat and humidity. Therefore, after an initial break-in period (about 20 hours), the sound should remain virtually unchanged for the life of the product.

Alesis' proprietary design tweeter features a pure Japanese silk dome, an internal pole-piece mounted phasing plug and low viscosity ferrofluid formulated specifically to retain the best balance of transient response to power handling. The shielded tweeter utilizes a vented pole piece with a separate rear chamber to lower the free air resonance. The very low 1500Hz crossover point of this tweeter produces an extremely wide dispersion, low distortion signal within the critical midrange frequencies. It is these frequencies which are often the most problematic in terms of getting "right" during a mix. The tweeter is designed for an optimal response for non-fatiguing, long term, high level, nearfield mixdowns. This design results in a flat, linear mix when played back on home or car systems from appropriate distances.

Magnetic shielding

Your M1 Actives are at home in recording environments wherein video is a major component. They are magnetically shielded for use in fairly close proximity (3" minimum) to a computer monitor or video screen. (Non-shielded components can make the colors of a screen "smear" or appear out of focus if the speaker is too close.) Magnetic shielding was designed into both the woofer and the tweeter from the beginning so that the system exhibits about 10 gauss (worst case) leakage. Shielding of both the woofer and the tweeter is accomplished by the use of a second opposing-field-oriented "bucking" magnet. The tweeter has an additional sixteen-gauge steel cup encasing the entire magnetic structure.

The M1 Active bi-amplifiers & electronic crossovers

The M1 active uses a 75W woofer amp and a 25W tweeter amp along with 8th order high and low pass electronic crossover filters centered at 1500Hz. Electronic crossovers, which separate the frequencies before being sent to the amplifiers, have fewer phase problems and less power loss than the traditional passive crossover used after the amplifier. Eighth-order filters are extremely steep (48 dB per octave), which minimizes the interaction between woofer and tweeter near the crossover point. Additionally, the high pass (tweeter) section of this system employs an electronic time alignment circuit. Thus the "launch" of frequencies from both the woofer and the tweeter will originate at exactly the same time.

There are several advantages to using built-in amplifiers and active (electronic) crossovers versus a passive network system, most of which have been previously enumerated in Vance Dickason's "Loudspeaker Design Cookbook":

- Lower intermodulation distortion due to amplifier operation over a more narrow bandwidth. Also, clipping caused by low frequency overload is reduced, being limited to only one driver within a two driver system.
- Increased dynamic range. The M1 Active's 75W and 25W amplifiers in their bi-amp setup will clip at about the same levels as one 200W amplifier operating into a passive crossover.
- Improved transient response.

- Better amplifier/speaker coupling for woofers.
- Better crossover performance working into a constant impedance load.
- Better subjective sound quality than high level (passive) networks.
- Easier control over driver sensitivity differences.
- Easier manipulation of phase, time delay, resonance, and various kinds of shaping, contouring and equalization.
- Specifically in the case of the M1 Active, the wide, mid-frequency polar response of the tweeter can be utilized down to a low 1500Hz thereby mating more cohesively with the 6.5 non-woven carbon fiber (NWCF) woofer. This low crossover is only possible through the use of a very steep, *electronic* eighth-order (48 dB per octave rolloff) high pass filter.

The M1 Active power supply

The M1 Active employs a regulated switching power supply. This type of supply has previously only been available in amplifiers sold at the very high end of the Pro Audio market.

Most power amp customers are familiar with the large transformer and output capacitors in high quality amplifiers. These large components are used to keep the amplifier's supply rails as close to DC as possible. For traditional supplies, bigger is better.

But by using Pulse Width Modulation (PWM) and output voltage feedback in the M1 Active, we have the equivalent of near-infinite transformer and output capacitors, but at a fraction of the cost. PWM provides protection from line voltage surges that would otherwise destroy the amplifier. No user-replaceable fuse is required because nuisance tripping is eliminated. And finally, PWM practically eliminates hum because the line frequency (60 Hz) transformer is replaced with a very high frequency (130,000 Hz) transformer.

The regulated supply rails increase the amplifier dynamic range and reduce clipping distortion under heavy loading. The compact size of the supply does not significantly reduce the internal air volume of the speaker cabinet. And lastly, full power can be maintained even with low or "flat-topped" line voltages.



Note, however, that this switching supply is NOT a universal voltage type that may be used with any input voltage in any country simply by changing the cord. If you wish to use the M1 Actives in a country whose line voltage is other than 120 volts AC, they must be internally modified or used with a step-down transformer.

The cabinet and port design

The M1 Active cabinet construction employs vinyl composite material laminated to a .625" MDF (medium density fiberboard) core for the four sides and the rear. The front panel is 1" thick MDF, to withstand the greater demands of the drivers mounted on it. The entire cabinet is braced extensively in random fashion to dissipate intramodal vibration.

Why the tweeters are offset

The M1 Active speakers have been developed as a mirror-imaged pair with dual front mounted ports and an offset tweeter. In some applications, an extremely wide dispersion tweeter, such as used in the M1 Active, will exhibit response dips if mounted exactly on center. Wave-guide style tweeters, used in other products, purposely limit dispersion and thus can be center mounted. But as hi-end audiophile speaker companies have found, a high quality dome tweeter, offset in the cabinet toward the *stereo "image center"* (*between the left and right speakers*) will have a flatter characteristic frequency *and* power response. This (flat power response) more closely characterizes the way humans hear.

On a horizontal polar response curve of the M1 Active, with the cabinet placed vertically, the tweeter response at one meter stays essentially symmetrical on either side of the cabinet's centerline. This is because the angle subtended between the cabinet-centerline-to-tweeter-centerline (.5"), and the nominal nearfield listening distance (1 meter or 39.375"), is only 1.27 degrees. Thus, acoustically speaking, the offset tweeter design has no negative effects, only the positive of smoothing the frequency response in the 2KHz-4KHz range.

In the tradition of the Alesis Superport design, which uses the energy from the back of the speaker to enhance bass performance, the M1 Actives use dual, front baffle mounted, long folded ports. The dual ports on the M1 Active are also non-symmetrical with relation to their distances from the woofer. In developing the M1 Active, Alesis engineers determined that dual ports, offset to the outside of the stereo image center gave the most coherent and extended low bass augmentation. The ports are flared on the front baffle to provide smooth and quiet exit airflow while inside they are cut with a 45° angle and faced toward the amplifier's internal heat sink. This arrangement aids in keeping the internal amps working at a more constant temperature. At the same time, this 45° angle increases the port's air entry efficiency.

About Nearfield monitoring

In the early days of recording, most recording studios used big monitor speakers almost exclusively. Unfortunately, they also required high powered amplifiers and expensive acoustic treatment (often poorly done) of the *entire* control room. Still, a well-constructed big monitoring system really was impressive to listen to, a fact not overlooked by the studio owners who wanted to impress the record company executives who paid for the big studio's time. These big systems had big level control knobs, and clients enjoyed "cranking-up" the volume. Fortunately, recording engineers and producers eventually learned that this was not the best way to accurately mix music because it wasn't the way most people listened to their radios, cassettes and CD players. Also, big monitor systems and the costs for the required control room acoustic treatments were going through the roof (no pun intended), particularly beyond the budget limits of smaller project and home studios which were growing in numbers. A new way of accurate monitoring was needed: nearfield monitoring.

Nearfield monitors, by their definition, are intended for mounting close to the listener. The idea here is to improve the direct acoustic path between the speaker and the listener by making it shorter, thereby giving less opportunity for the always present indirect (reflected) sounds to get back in and muddle things up. With nearfield monitoring, the surrounding acoustic environment becomes a much less significant factor in establishing the monitor system's sound character.

A good set of small monitors properly placed in a reasonably non-reverberant room and properly powered will yield surprisingly accurate results at budget prices. Carried to another studio, the same monitor should also provide *repeatable* results. In fact, some recording engineers carry their own speakers around because they know how they will sound in almost any room. Now, even the big studios use smaller speakers to augment their big monitoring systems, and nearfield monitors have become proven tools in the recording business.

SPEAKER INSTALLATION

Like any speaker system, your M1 Active speakers will work best when properly positioned in a suitable acoustic environment. Achieving proper speaker placement is usually straightforward, but even with nearfield monitors, speaker placement and the acoustics of the listening room itself are too often overlooked and can become significant contributors to an inaccurate and uninspiring monitoring environment.

Avoiding reflections in the studio

While nearfield monitors are more forgiving of the surrounding room acoustics, it is always prudent to optimize the listening environment whenever possible. First, the user should be aware of the effect that the size of the listening room can have on low frequency response. In general, the smaller the room, the stronger the bottom end will be, although placement within a larger room can also make a difference. This has to do with the way low-frequency waves travel in closed spaces. If you find your monitor system to be either light or heavy on the bottom, try moving them around within your listening room.

You should avoid locating your M1 Actives near reflective surfaces such as glass, tile, large open walls or table tops. Still, many rooms used for recording have these surfaces, so the best way to deal with them is to place the monitors out in the room away from reflective walls, windows and sizable objects. Even with these reflective surfaces separated from the monitoring position, typical mixing situations usually still have the top surface of the mixing board to deal with.

Unfortunately, the board itself can be a major source of reflections and the additional acoustic conduction into the board can affect your monitor's amplitude and phase response. Speaker placement on the console's meter bridge allows two different acoustic paths between the speakers and the recording engineer, which results in undesirable comb filtering effects and poor imaging. The first path is the direct one, and the second is via a reflection off the mixer main control panel:

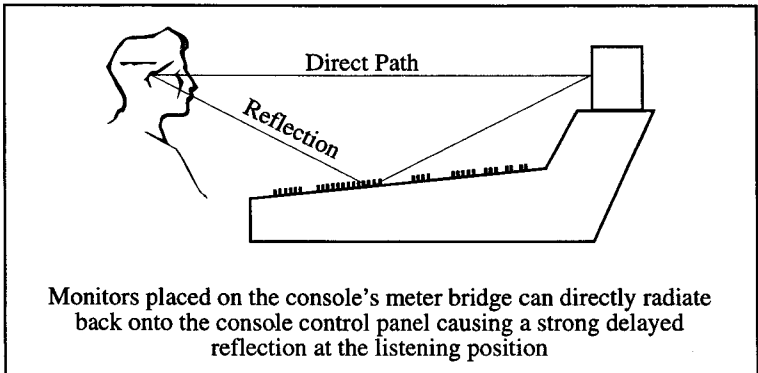

Speaker Installation

This kind of speaker placement also couples acoustic energy from the speaker's cabinet more readily into the console's chassis. Both conditions should be reduced by placing the speakers on their own stands acoustically detached from, and slightly behind, the console as shown below. In this location, the reflective path off the console's control panel is now blocked by the meter bridge.

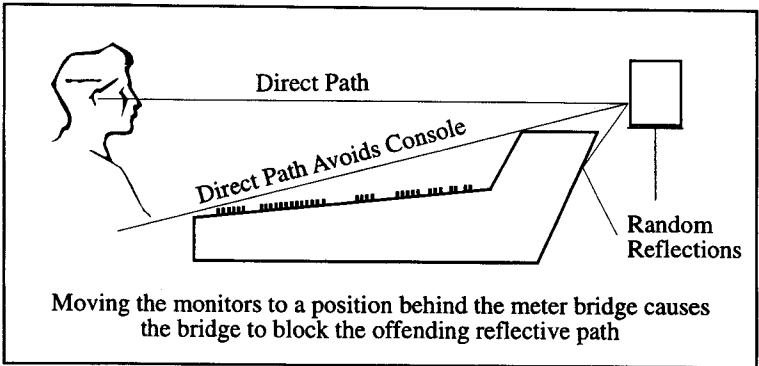

Careful consideration should also be given to the physical spacing between the speakers. Alesis recommends that the distance between the speakers for stereo applications equal the distance between the listener and either speaker. In other words, the listener and the two speakers are at the three corners of a triangle having equal-length sides. The illustration below shows this concept. Note that both speakers are turned in somewhat, so that the prime listening position is directly in front of each speaker. Applications that require monitoring by more than one engineer are accommodated by a smaller rotation of the cabinets. This will widen the prime listening position somewhat.

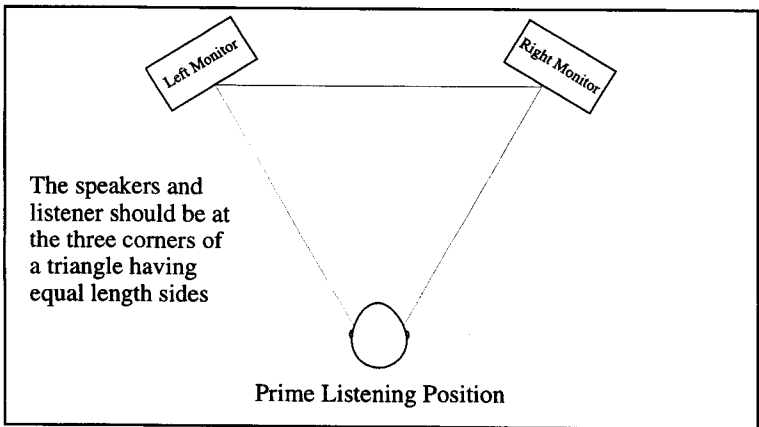

NOTE: On some mounting surfaces the vinyl finish of the M1 Active's cabinet may cause it to slip too easily. Included with this reference manual packet are two pieces of adhesive backed non-skid foam. If necessary, apply the pad to either the bottom (for vertical placement) or cabinet side nearest the ports (for horizontal placement). If you plan on using the M1 Actives in both modes, simply cut the pad in half and apply to both the bottom and the side nearest the ports).

Stereo nearfield placement of the M1 Active

NOTE: We recommend that the M1 Active speakers be placed with the tweeters to the **inside**, not the outside, of the listening triangle.

The "classic" studio monitor layout used to be that the tweeters be placed to the *outside* of a horizontally-oriented speaker. In the past, this configuration was actually beneficial in time aligning the tweeter with the woofer *if* the cabinets were not toed-in toward the listener. However, this configuration is highly prone to comb filtering effects if the listener's head is moved from side-to-side while mixing. This "comb filtering" causes the mid-to-high frequency tones to get louder, then softer, then louder again as you move your head from side-to-side, making it very confusing when trying to mix with precision.

Some people still believe that stereo separation is "improved" with tweeters to the outside, but this is advice left over from the early days (the sixties) of stereo recordings when "correct" stereo often meant a complete hard right or hard left placement of an instrument (or singer). As stereo mixing techniques changed toward placing the vocalist (for example) in the center, the old "tweeters-out" orientation would indeed widen the image *if* one's head were kept in the *exact center* position. But this set-up proves to be very tiring, very quickly for the recording engineer. And, to others who are listening to the mix from either side of the engineer, the sound will seem to be coming primarily from the speaker closest to them.

Fortunately, recording techniques have changed radically since the sixties. Engineers have learned to how to "place" an instrument or singer within the mix so that an accurate re-creation of the actual instrument and vocal positioning (left-to-right and front-to-back) is achieved. In the M1 Active, advances in crossover design technologies and improvements in the off-axis response of tweeter domes and woofer cone materials and profile have made the requirement for tweeters to be placed to the outside of the cabinet obsolete. **In fact, using a non-toed-in, tweeters-out orientation with a modern, wide dispersion design like the M1 Active will increase the likelihood of hearing unwanted first reflections and a variety of phase anomalies in your mix.**

Horizontal Placement Recommendation

Traditionally, proper horizontal placement of speaker systems slightly *behind* (not *on*) a meter bridge accomplished two purposes: it allowed both woofer and tweeter to be at ear level, and many times, it permitted the recording engineer to see over the speakers and into the studio.

Horizontal placement is a recommended arrangement with the M1 Active because the left and right mirror-imaged pair permits a symmetrical alignment of drivers and ports. This will be conducive to a balanced mix. See Figure 2 below.

Proper tweeter orientation is toward the stereo image center (the middle) as shown. Ports are always faced toward the bottom side of the cabinet. This set-up will promote a strongly focused center image such as for the vocalist. And because the (vocal) image width will be narrower than if the speakers are placed vertically, it will be possible to place the vocalist with great precision at stage center. In this orientation there will be much less chance of first reflections from either sidewalls or the console coloring your mix.

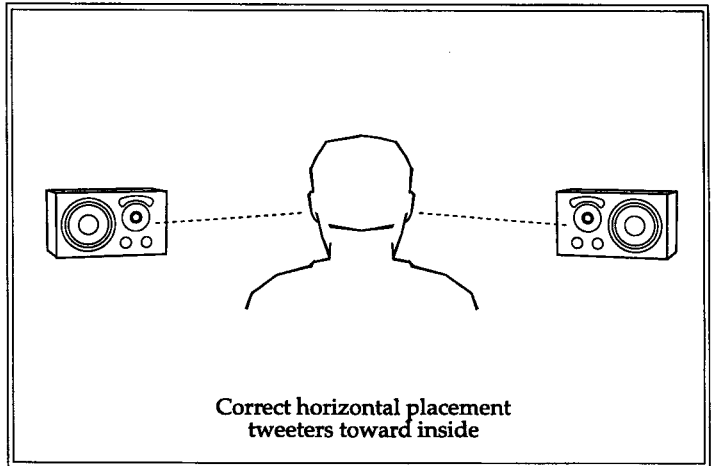

Vertical Placement Recommendation

Vertical placement of the M1 Active as shown in Figure 3 is highly recommended. This position will simulate the soundfield that will be heard in most consumers' homes and (to a great extent) their cars. For this reason, even if the M1 Actives are positioned horizontally for all of the mixing, the vertical position should always be used in the final "playback check" mode. (See next section)

There are a couple of possible drawbacks to vertical placement of a nearfield monitor relating mostly to room interaction effects. Vertical placement allows the M1 Actives to portray your mix with the widest and deepest soundstage possible, so many people in the control room have an image of the "sweet spot". However, this wide a dispersion pattern in a control room with walls in too-close proximity to the speakers can add strong reflections to the sound you hear, muddying your mix. Figure 4 shows the control room placement/ distance recommendations, which should help you determine if your available recording space would work well with the M1 Actives set up vertically.

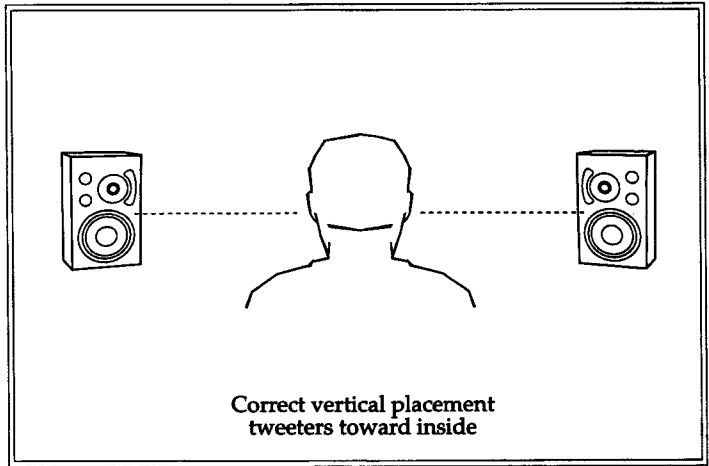

Playback check mode (vertical mid-field)

After you've got your mix just right it's always good practice to perform a "playback check" by standing the M1 Actives vertically and making the listening triangle larger. The purpose of the playback check is to simulate what your masterpiece will sound like in a "typical" home listening environment. It is in this configuration that the imaging specificity of your mix can best be evaluated. Generally, in the playback check mode you want to arrange the speakers in the same equilateral listening triangle that you do in a nearfield setup, but instead of each side of the triangle being about 3 feet long, the distances between stereo speakers and to your listening position should be between 7 and 12 feet.

When setting the left and right speakers vertically, place the tweeters toward the center with the ports toward the outside. In this vertical position, the M1 Active becomes a "line source" speaker which is the most common home set up. (A 12" three-way with woofer on bottom, midrange in the center and tweeter at the top is a line source, as are most forms of tower speakers.) When the M1 Active is set vertically in its "column" configuration, the *horizontal* dispersion (left and right) of the speaker is widest, and the vertical dispersion (up and down) is narrowest.

Unfortunately a vertical setup will also increase room effects, so there are minimum recommended setup distances from side and back walls: the speakers should be a *minimum of 2.5 feet* from the side walls and *3 feet* from the rear walls. See the illustration on page 26.

After you've got the requisite distances from the side and back walls, it's often helpful to adjust the 7 to 12 foot equilateral listening triangle distances. What you want to find is the maximum distance that you can separate the two speakers while still holding a solid center image. If you get this placement correct *and* you've done a good job in the mix, you should be rewarded with a soundstage that accurately places the musicians in the width and depth perspective in which they were recorded. The sound should be very similar to what you heard at your mixing board, with possibly a little more ambience contributed by the listening room.

The "other" playback check mode, sometimes considered of greater importance than the home environment, is to listen to your mix over a car audio system. Bear in mind that an expertly designed car audio system can approach the imaging and soundstaging capabilities of an optimally setup studio or living room, but most times this is NOT the case. The inherent limitations of an always-off-axis listening position and the variables of speaker placement, bass coupling (boost) in the small interior and numerous other factors make the car environment highly suspect. So, understand the sonic capabilities (and deficiencies) of your (or other) car audio systems, and evaluate your mix accordingly.

Plugging the ports to adjust for room acoustics

The low frequency response of the M1 Actives can be custom tailored by plugging the ports. If the speakers must be placed less than one foot from a front wall, or if they are too close to a corner, then the bass may become exaggerated and inaccurate. The rules of thumb for these situations are as follows:

- a) less than 1 foot from a front wall but *away* from any corner:
plug one port
- b) less than 1 foot from a front wall *and* a corner:
plug both ports

The "plug" can be wad of cloth to completely block the port(s) or a more porous material like fiberfill which will give less bass attenuation. The bass output of the M1 Active is thus easily variable depending on in-room positioning and/or personal preference.

If the M1 Actives are to be used in a system with a subwoofer, the proper blend of the two systems is critical if low-bass accuracy is to be maintained. Here again, your ear is your most important piece of test equipment. If the subwoofer (such as the Alesis Point One) or preamplifier has 80Hz high-pass filters built-in for connection to the other amplifiers, then no port plugging is necessary. The proper match will have already been taken care of electronically. In the absence of an 80Hz high-pass filter feeding the M1 Actives, you'll need to experiment with various degrees of port plugging to minimize the cancellations and nodes that can occur from bass sources placed several feet apart in a room. In practice we've found that a single port plugged with cloth is usually the best compromise. See Figure 5 below. It shows the approximate bass attenuation that can be expected with one port plugged.

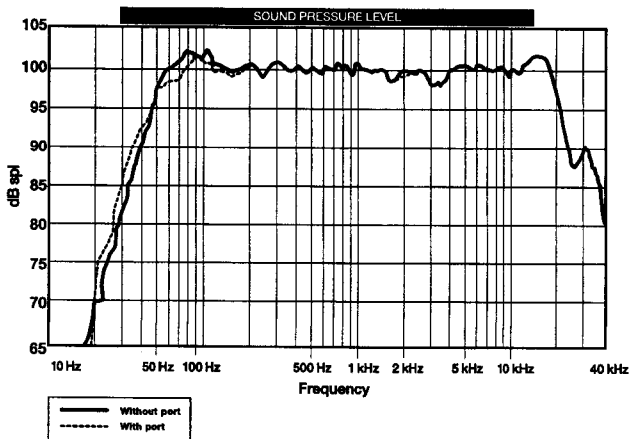

Connections

The M1 Active has been designed to be as simple as possible to set up and use. However, please follow the instructions to ensure that you get the best possible performance from your monitors.

Before connecting the speakers, make sure the power switches of the M1 Actives and any equipment they will be connected to are turned OFF.

AC power cable

READ ALL SAFETY WARNINGS IN THE PREVIOUS SECTION OF THIS MANUAL TO ENSURE SAFE OPERATION OF THESE UNITS. Connect the M1 Actives to the specified power using the AC cables supplied. The AC cables are removable. If the distance to your AC outlet is longer or shorter than the supplied cable, you may substitute an approved standard NEMA-to-CEE power cable of the correct length, available from most electronics stores.

Grounding



CONNECT THE M1 ACTIVES TO A PROPERLY GROUNDED OUTLET ONLY. DO NOT USE ADAPTERS WHICH REMOVE THE SAFETY GROUND PROTECTION OR CUT OFF THE GROUNDING PRONG ON THE POWER CORD. Proper grounding is essential for user safety and low noise. If you experience 60-cycle hum in your sound system as a result of different ground potentials between different units in your system, plug all units into the same AC circuit (if the total power load allows) and make sure other devices in the system are properly grounded themselves. The M1 Active features balanced inputs, so if it is properly connected to other balanced units, AC ground potentials will not affect the audio. If you cannot get rid of ground loops, consult a professional electrician familiar with sound system power designs.

Use clean power

The M1 Active's internal power supply is designed to filter out most AC line noise. However, it is still good practice to plug your sound equipment into an AC circuit that is not shared with lighting dimmers, refrigerators, air conditioning units, or other appliances that may induce noise into the power system.

Power switch

The POWER switch is located on the back panel. A blue power indicator lamp is on the front panel.

Input Connections

Almost any conventional line-level source may be plugged into the M1 Active's LINE INPUT jack. The Line Input jack accepts both XLR and 1/4" input plugs wired either balanced or single ended (unbalanced). The best connection is to use a high-quality XLR-to-XLR "mic cable" between the output of the source (usually, the CONTROL ROOM OUTPUT of the console) and the speakers. A conventional 1/4" "patch cord" TS type plug will also work for unbalanced sources which automatically ground the minus input.

Polarity: Input connector wiring is printed to the left of the connector on the back panel and is as follows:

- + Pin 2: tip ("hot")
- Pin 3: ring ("cold")
- Shield Pin 1: sleeve (ground)

A positive voltage on the "hot" connector will cause the drivers to move outwards.

Unbalanced Line Input

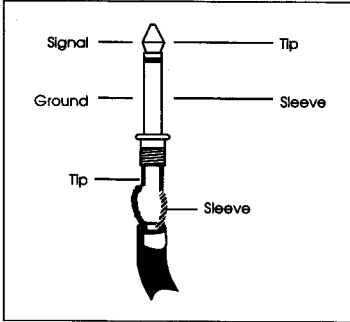

Balanced Line Input

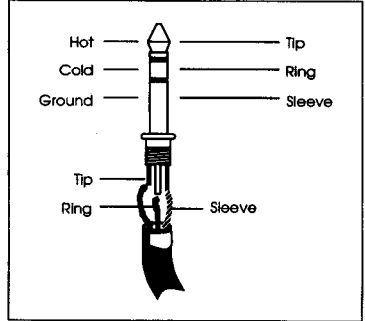

Direct connection of unbalanced -10 dBV line level sources: Most synthesizers, drum machines, effect devices, cassette decks and CD players operate at this level. Their average signal level is about 1/3 of a volt. They have a 2-conductor output jack that is either a 1/4" phone or "RCA phono" type. These may be plugged directly into the M1 Active's LINE IN jacks.

But do NOT plug the speaker output of an amplifier, receiver, or similar device into the LINE INPUT jack. Use only line-level sources. Plugging too loud of a signal into the LINE INPUT jack may damage the electronics.

Balanced +4 dBu line level sources: Professional recording and processing equipment typically provides a balanced, 3-conductor signal output that is a higher voltage (1.24 volts nominal level) than most synthesizers and stereo equipment. The LINE INPUT jacks are designed to handle these balanced inputs.

Balanced sources often feature XLR outputs. Connect them with an XLR-to-XLR cable. Many consoles (such as the Alesis Studio series) feature balanced outputs on

Speaker Installation

1/4" jacks; you may use a TRS-to-TRS balanced phone cable, or an XLR-to-1/4 inch phone TRS (tip-ring-sleeve) cable, as shown below. The advantage of using an XLR on the speaker side is that it is a locking connector and cannot be accidentally disconnected.

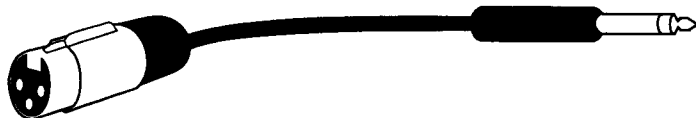

NOTE: Use high quality input connectors which conform to industry standard sleeve dimensions. Some off-brand connectors, particularly cheap 1/4" TRS plugs, do not provide reliable connections because of slight dimensional differences.

Setting the Input Level control

In most cases, the INPUT LEVEL control should NOT be set at full rotation. For best system dynamic range, follow the instructions below.

The goal is to set the input level of the M1 Actives for the desired listening level, when all the rest of the system is at its nominal operating level. "Nominal" means its normal average level, expecting peaks from 8 to 15 dB above that on occasion. For the best signal-to-noise ratio, everything *before* the M1 Active should be as loud as possible. The M1A's INPUT LEVEL control, being last in the signal chain, is the worst place to make up gain lost earlier in the system.

To set the level with a mixer:

1. Turn on all system components (the M1 Actives last) and turn the M1 Active's INPUT LEVEL control all the way down.
2. Play program through the mixer and raise the mixer's fader levels until its meter averages around "0 VU".
3. Raise the Control Room Output to its nominal position (usually "2 o'clock" or 3/4 of the way up).
4. On one speaker, raise its INPUT LEVEL CONTROL for a comfortable level in the engineer's seat (if you have a sound pressure meter, 85 dB SPL is a common standard for listening).
5. Match the level for the other speaker. Note that the numbers on the back panel are only a rough guide; for precise left/right imaging, use pink noise or test tones and a sound pressure meter.

The Input Level control has a 28 dB range with a center detent. The detent has no particular meaning, but helps in adding a mental "reference position" when attempting to set levels from in front of the speaker. With the control at a maximum clockwise rotation, 2.0 volt input will produce full amplifier output (102 dB SPL "A" weighted from two speakers at 1 meter).

For the technically-minded, here is an approximate chart of SPL levels for various settings of the INPUT LEVEL control, measured at 1 meter from two speakers simultaneously (all settings, especially near the extremes of the range, are subject to a plus or minus 2 dB error):

Mark	-10 dBV nominal	+4 dBu nominal
0 (MIN)	-- dB SPL	-- dB SPL
1	--	--
2	57.0	69.0
3	63.5	75.5
4	68.2	80.2
5	71.0	83.0
6	73.0	85.0*
7	78.0	90.0
8	83.5	95.5
9	85.5*	97.5
10 (MAX)	86.5	98.5

* denotes recommended setting for control room use

Avoiding damage

The best protection against speaker failure is to mix at a reasonable listening level. With a +4 dBu input and the input level control set to "6", the M1 Active speakers produce a sound pressure level (SPL) of 85 decibels at 1 meter, which is a good working level for mixing. At maximum output before clipping, they can generate peak levels ≥ 118 dB SPL at one meter – a level which may cause hearing loss after prolonged exposure. While the biamplified design of the M1 Active avoids the common "blown tweeter" problem of conventional designs (when a broadband amplifier clips on a bass note, it sends unusually high energy to the tweeter, which tries to reproduce the square wave), it is not invulnerable. If you need higher power levels, you are not using the speaker in a near-field application. For extremely loud mid-field and far-field monitoring, we recommend the Alesis Monitor Two speaker with a 300-watt per channel amplifier. Many studios will check recordings on both systems, alternating to avoid ear fatigue and to gain perspective on the mix.

SURROUND SOUND

About surround sound

Surround sound is the term used for several different systems which use multiple channels of playback in the listening room to recreate a truly three-dimensional sound experience. The practice of recording music-only in surround sound is a fairly recent innovation. Surround sound for video, however, has been around for over ten years. With modern encoding methods, multichannel audio may be delivered to consumers on standard video tape, video discs, and even through broadcast, with the proper *encoders* (devices which take multiple channels of audio and combine them into two channels) and *decoders* (used at the receiving end to split the signal back into multiple channels).

Systems are in use which use three (left, right, and surround), five (left, center, right, left surround, right surround, often supplemented by a sixth subwoofer channel), and more speakers. The original Dolby Surround® of the mid-eighties was a matrixed three-channel-only system. It had left, right and a mono surround (rear) track, which was usually played through two surround speakers. In 1987, Dolby Pro Logic®, a four-channel matrix system, was introduced. Pro Logic added a dedicated center channel to which most dialog was assigned. The rear surround channel was still in mono. In 1996, Dolby Digital® (AC-3) and DTS, fully discrete six-channel audio delivery platforms with separate left-rear and right-rear channels first became available to consumers on laserdisc and, more recently, on DVD (Digital Versatile Disc).

With so many listeners hearing music through their multimedia systems, it is important for engineers to produce music on surround systems, even if they're not working for film or video applications. Powered monitors like the Alesis M1 Active Bi-amplified Reference Monitor have proven to be a simple, cost-effective way to add five-channel surround to control rooms.

Center speakers in music mixes

In video applications, with left, center and right channels all set to deliver equal output, the ear tends to hear dialog as coming only from the center channel. (It's a psychoacoustic effect because all right and all left channel signals are fed to the center.)

In Dolby Pro Logic, the center channel information is derived from sum and difference information encoded in the left and right channels. The very attributes that make this matrix-type system viable for video application make it less desirable for music-only reproduction. In practice, there is a hard center dialog channel but there is also a sort of phantom mono channel developed between the left and center channel and the right and center channel. This between-channel phantom mono image exists because so much of the information contained in each channel (left and center or right and center) is identical. Hence, mono. In the few music-only recordings encoded in Dolby Pro Logic, the derived center channel could lead to some drastic changes in spatial perception.

In developing the M1 Actives for use as left, center and right front channel sources, we wanted them to be useable in both audio/video *and* audio-only "matrix" type applications. We discovered two, already available solutions to the large "wall-of-mono" effect produced by Dolby Pro Logic when playing audio-only material. The first is easy. Most home audio Dolby Pro Logic receivers will let you take the center channel out completely by putting the receiver in the "phantom" (no center channel) mode. It preserves the classic stereo effect of the front channels while adding rear surround. This method works well with most stereo-only recordings which have no surround encoding. But it's much better if the rear channels have true matrix (mono) surround (like applause) encoded in the mix.

The second method of using Dolby Pro Logic gets the center channel back into the mix. Most of these same home audio receivers have an audio-only surround mode which significantly attenuates the output of the center channel in relation to the left and right. The audible benefit here is that the mix sounds like a stereo only recording but the center image (like a vocalist) becomes a *hard* center. There is no image wander, as the frequencies change, for instance. And the classic listening "sweet spot" expands dramatically, allowing for accurate soundstage and instrument placement when listening far off-axis. (This attenuating of the center channel for audio only is also employed by advanced professional matrixed decoders such as the Circle Surround, Miles Technology and Lexicon units.)

Placement of the center M1 Active speaker in the studio

The left, center and right speakers should all be placed in an arc so that the distance of all drivers to the listener is identical (see page 29). The equilateral listening triangle as described earlier for stereo (two-channel) playback should be retained, with the center speaker placed *vertically* in the center, exactly between the left and right (vertical) M1 Actives.

It does not matter what type of M1 Active is used for the center speaker (tweeter in or tweeter out). Since M1 Actives are sold as pairs, a 5-channel system requires the purchase of a single speaker, breaking up a pair. Some dealers may request that you purchase in pairs only; others may be able to arrange purchase of a single unit. For the rear channels, we recommend a mirror-image pair, although this is less critical than in the front.

As discussed above, for music-only recording the signal level to the center channel will be attenuated over the levels of the left and right speakers. As a starting point we would recommend that you set the center channel level -6dB below the left and right channels. To get these levels fairly accurate a white or pink noise source (such as from a test CD) is very helpful along with an inexpensive sound level meter (such as the Radio Shack cat. no. 33-2050).

If you are recording audio-for-video, the center channel signal level should be *the same* as left and right channels. The left, center, right speaker layout configuration can remain the same as for an audio-only mix. With all front speakers operating at equal levels, the "sweet spot" listening area will become very large but the "wall-of-mono" effect mentioned above (in regards to music) will be of little consequence since most of the dialogue will be mixed specifically into the center channel.

Placement of rear surrounds

The following suggestions for optimal M1 Active placement are derived from several sources: 1) Standard industry practice for home installations as recommended by the manufacturers of surround encoder/decoder units; 2) recommendations developed by Tom Holman for setting up THX surround theater sound systems, and 3) Alesis engineers' experience fine-tuning the performance of the SMS Monitoring System in order to find the mounting configuration which results in the most natural and accurate surround placement. With the many different playback systems in use, there is room for interpretation of what the best placement is in a control room, but the following represents a good starting point which you are free to change to your taste.

Vertically, the M1 Actives should be placed on the side wall of the control room, above your head, with the woofers on top, tweeters on the bottom. The ideal location is to have the center of the speaker (between the woofer and tweeter) at **80% of the floor-to-ceiling height**. (For a standard 8 foot ceiling height the center line would be at $96'' \times 80\% = 76.8''$ from the floor.)

Recommended positioning of surround speakers

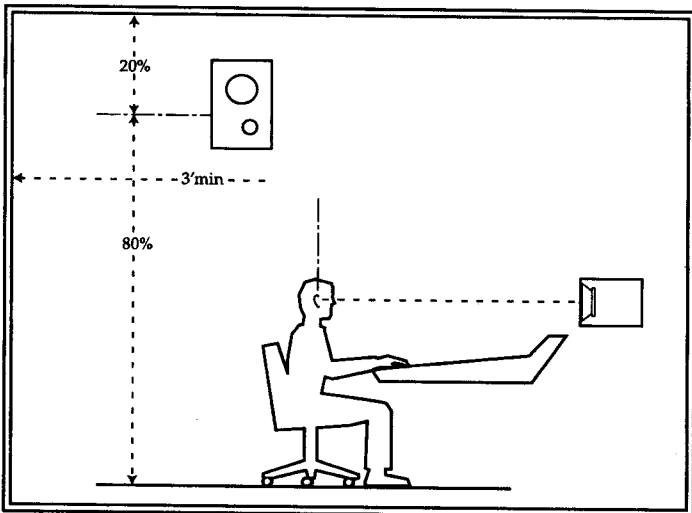

Horizontally, place the M1 Actives slightly behind the 90° position, at 110° on each side. Make sure that at the position used, there is still at least 3 feet to the back wall of your studio. If you do not have at least 3 feet to the back of your studio, then the speakers will work better if placed diagonally in the rear corner as shown on the next page.

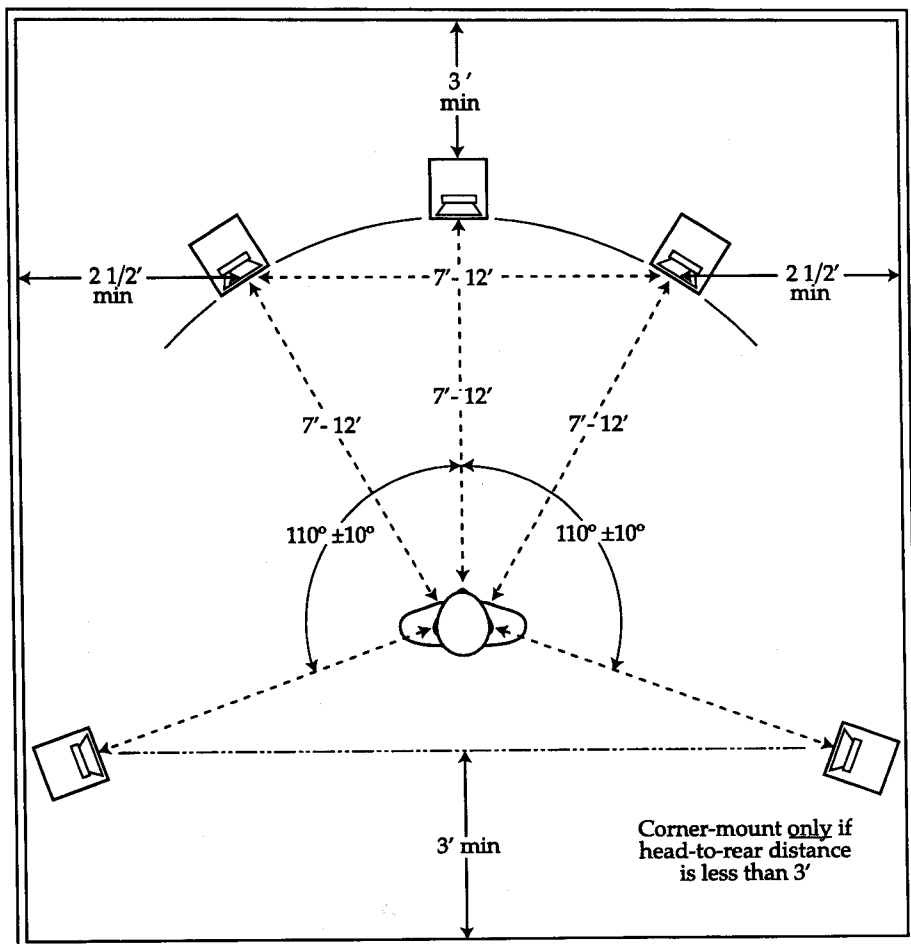

Wall mounting

Once you have located the general area for the horizontal and vertical position, you need to find a wall stud. Attach shelving brackets or other commercial speaker-mounting device into the wall stud, then attach the M1 Actives to the mount, allowing room for the rear-panel input and AC connections.



The M1 Actives weigh 19.5 lbs., so it is vitally important that any stand they're resting on be securely mounted through the wall material (usually 3/4" sheetrock, which by itself does not have the strength to support the speakers) and into a wooden stud using hardened screws or other fastener rated to hold at least two times that weight.

Mixing for discrete six channel reproduction: matched vs. specialized speakers

While most speaker systems for monitoring music in surround use the same speaker cabinet in all positions, both front and rear, keep in mind that most consumer video surround installations use a different speaker in the rear channels. These rear speakers typically do not have the same directionality or wide frequency response of the M1 Actives. When mixing for film, speakers with a broad ambient, non-directional response are used to mimic the multi-speaker situation in most movie theatres. Keep this in mind when making music mixes with full-range high-power speakers like the M1 Actives as the surround speakers.

The difference between music surround and video surround playback has a long history:

- Dolby Pro Logic, which works best with dipole (i.e., speakers played in different directions out of phase) surround speakers, has been *the* standard for surround sound in the home for 10 years.
- The most accepted home playback medium, VHS videotape, can only play back (mono) surround in Dolby Pro Logic. VHS will not support Dolby Digital or DTS.
- There are only two playback mediums, laser disc and DVD, that support Dolby Digital (discrete) and DTS (discrete). After 20 years in existence, laser disc has only a 2% market share. Some digital satellite broadcasters have started broadcasting in Dolby Digital, but these discrete broadcasts will be reserved for blockbuster movies initially.
- Discrete Dolby Digital, DTS and Sony's SDDS are most commonly mixed for theatrical release using surround, not monopolar (direct) monitors.
- Among the recording engineers who have recorded audio-only, the consensus seems to be that the role of the surround speaker is to give the listener a *sense of immersion* in the musical event. This is done by reserving the rear channels for audience sounds, in the case of a live recording, or perhaps by reproducing the reverberant acoustics of the recording environment itself. Other engineer/producers prefer using five identical full-range speakers and mixing primary instruments and vocals into the surround channels.

So, our basic recommendation for mixing an audio-only six channel recording is to intentionally limit the frequency response of the rear speakers using a graphic equalizer or high-pass (100 Hz rolloff)/low pass (12 kHz rolloff) filter on your mixer. This will help you get a rough idea of what a home system playback will sound like.

This arrangement will also allow your mix to sound best over a well set up car audio system. This is because professional installers have learned that a mobile system performs best when they concentrate on producing a soundstage across the *front* of the vehicle. They do this by placing high quality drivers in the front of the vehicle which produce frequencies from the mid bass (about 80Hz) on up. In the rear go the subwoofers and sometimes, small full range drivers which provide "fill". So, in essence; today's best car audio systems are designed to produce an enveloping environment very similar to that of a home theater.

Surround Sound

The use of M1 Actives (or any monopolar speaker) as full-range surrounds would be useful in the following cases:

- If the surround speakers are just as important as the fronts in achieving a specialized effect, such as completely mixing the sax in the left rear only and a flute in the right rear.
- If you know that your mix will always be played back on a monopolar surround system.
- If the control room is completely damped with sound absorption on all surfaces. (This renders the reverberant-field generating properties of a bipole/dipole speaker ineffective.)

* Dolby Surround, Dolby Pro Logic, and Dolby Digital are trademarks of Dolby Laboratories, Inc.

TROUBLESHOOTING

Troubleshooting Index

If you experience problems while using the M1 Active/Surround systems, please use the following table to locate possible causes and solutions before contacting Alesis Technical Support for assistance.

No sound	Speaker disconnected	Check input cable connections
	INPUT LEVEL down	Turn up input control on back panel
	AC power not on	Blue LED on front should be on. Check switch and power input cable.
Unfocused sound, bass frequencies muddy or missing	Inputs out of phase	Check + and - connections from mixer to input. Verify "pin 2 is hot".
	Subwoofer being used improperly	Install port plugs when using a subwoofer
	Poor mix	Compare to commercial CD of similar style: time to remix your track....
Distorted output	Power amp overloading speakers	Turn down level
	Damaged speaker components	Swap channels to see if the problem follows the speaker; if so contact Technical Support

Maintenance

Cleaning

The cabinet surfaces of the M1 Active are covered with a vinyl laminate. Clean these surfaces when necessary with a lint-free cloth dampened in warm soapy water. **USE ONLY A DRY CLOTH ON THE BACK PANEL OF THE POWER AMPLIFIER.** Do not attempt to clean the cabinet with a brush (which may damage the surface) or a sponge (which may leave small crumbs in the texture).

Do not attempt to clean either of the drivers.

The M1 Active/Surround speakers require no periodic maintenance.

Refer All Servicing to Alesis



We believe that the M1 Active is one of the most reliable powered monitors that can be made using current technology, and should provide years of trouble-free use. However, should problems occur, **DO NOT** attempt to service the unit yourself. Service on this product should be performed only by qualified technicians. **THERE ARE NO USER-SERVICEABLE PARTS INSIDE.**

Service

Before sending the M1 Actives in for repair, make sure they are faulty and that the problem isn't being caused by something else in the system. Distortion or noise may be caused by a defective preamp, cable, equalizer etc., or a loose connection in the system. Connect the speakers to a system that is known to be working properly to check whether the monitors have malfunctioned.

Obtaining Repair Service

Before contacting Alesis, check all your connections, and make sure you've read the manual.

Customers in the USA and Canada: If the problem persists, call Alesis USA at 1-800-5-ALESIS and request the Technical Support department. Talk the problem over with one of our technicians; if necessary, you will be given a return order (RO) number and instructions on how to return the unit. All units must be shipped prepaid and COD shipments will not be accepted.

For prompt service, indicate the RO number on the shipping label. Units without an RO will not be accepted. If you do not have the original packing, ship the M1 Active in a sturdy carton, with shock-absorbing materials such as styrofoam blocks or "bubble-pack" surrounding the unit. Make sure the drivers will not be pressed on by the packing in shipment. Shipping damage caused by inadequate packing is not covered by the Alesis warranty.

Tape a note to the top of the unit describing the problem, include your name and a phone number where Alesis can contact you if necessary, as well as instructions on where you want the product returned. Alesis will pay for standard one-way shipping back to you on any repair covered under the terms of this warranty. Next day service is available for a surcharge.

Field repairs are not normally authorized during the warranty period, and repair attempts by unqualified personnel may invalidate the warranty.

Correspondence address for customers in the USA:

Alesis Product Support
1633 26th Street
Santa Monica, CA 90404

THIS IS NOT A SERVICE LOCATION. DO NOT SHIP UNITS TO THIS ADDRESS.

Customers outside the USA and Canada:

Contact your local Alesis distributor for any warranty assistance. The Alesis Limited Warranty applies only to products sold to users in the USA and Canada. Customers outside of the USA and Canada are not covered by this Limited Warranty and may or may not be covered by an independent distributor warranty in the country of sale. Do not return products to the factory unless you have been given specific instructions to do so.

SPECIFICATIONS

Enclosure

Materials and Construction

Front baffle painted in metallic charcoal-gray, one inch (1") thick MDF with radiused edges to minimize diffraction. Sides and rear baffle covered in metallic charcoal-gray vinyl laminate, over five-eighths inch (0.625") thick MDF.

Multiple, internal, random spaced and length edge boundary cleats break up and elevate common frequency mode aberrations.

Dual ports with 45° inlet and flared, front baffle outlet allow precise, phase accurate woofer-to-port frequency transition. Ports also aid in cooling internally mounted primary amplifier heat sink.

Flush mount, rubber woofer trim ring allows consistent power response characteristic at wide off-axis angles. Flush-mount tweeter plate and Alesis M1 Active logo/pilot light plate also assure smooth off-axis response.

UL-approved fiberglass acoustical damping material damps internal mid-frequency reflections from rear of woofer cone before entering port, lessening IM distortion.

Transducers

Low frequency driver:

6.5" (165mm) diameter dynamic driver with proprietary non-woven carbon fiber (NWCF) cone and 1.5" diameter, long-wind voice coil.

Santoprene surround with moderate internal damping and constant linear displacement Nomex spider. ±5 mm X-max excursion capability.

Dual magnet structure uses top magnet in opposed ("bucking") configuration for magnetic shielding (≈10 gauss at outside edge of cabinet).

High frequency driver:

1" Japanese-silk-dome tweeter.

Medium viscosity ferrofluid cooling extends power handling while retaining impulse response capability.

Dual magnet structure uses top magnet in opposed ("bucking") configuration for magnetic shielding. Additional 16 gauge low carbon steel cup lowers leakage to ≈3 gauss at outside cabinet top or side.

Crossover section

Crossover type:	Eighth order, 48dB/octave Linkwitz-Riley @ 1500Hz
Input Impedance:	20k Ω balanced 10k Ω unbalanced
Low Frequency Filter:	2nd order optimal Q high pass filter at 50Hz with +1dB boost

Amplifier Section

Low Frequency Amplifier

Rated power output:	75 watts, 6 Ω load
Distortion:	<0.03% THD @ 30 watts/8 Ω 20Hz-20kHz
Slew rate:	19V/ μ sec
Signal-to-Noise ratio:	>110dB referenced to 60 watts @ 8 Ω , "A" weighted, 1kHz

High Frequency Amplifier

Rated Power Output:	25 watts, 4 Ω load
Distortion:	0.06% THD @ rated power
Slew rate:	9V/ μ sec
Signal-to-Noise ratio:	>112dB @ rated output

Acoustic Section

Free-Field Frequency Response:	\pm 2dB, 50Hz to 20KHz
Lower Cutoff Frequency:	38Hz -10dB
Upper Cutoff Frequency:	23.5KHz -10dB
Maximum Peak SPL per pair:	\geq 118dB SPL @ 1m
Maximum short term SPL:	80Hz to 3.0KHz \geq 105dB SPL @ 1m

General

Power Consumption:	120 watts with musical program, loud mix 12 watts quiescent (idle)
AC Dropout Voltage:	120V AC version: 80V AC 240V AC versions: 160V AC
Weight:	19.5 lbs. (8.9 kg) each
Dimensions (H x W x D):	15" (381mm) x 8.5" (216mm) x 9.75" (248mm)

- AC power, 12, 22, 37
- amplifiers, 10, 11, 37
- balanced, 23
- biamplified, 10
- crossover, 10
- crossover, 37
- dispersion, 19
- frequency response, 10, 37
 - with ports plugged, 21
- fuse, 12
- grounding, 22
- INPUT LEVEL, 24
 - detent, 24
- interference, 7
- LINE IN, 23
- Magnetic shielding, 11, 36
- mounting, 17
- nearfield, 14
- noise, 22
- placement, 15
 - horizontal, 18
 - surround, 28
 - vertical, 19
- Playback check mode, 20
- Polarity, 23
- ports, 13
 - plugging, 21
- power supply, 12
- reflections, 15, 17, 18
- Safety, 3
- service, 4, 34
- spacing, 16
- SPL, 24, 25
- subwoofer, 21
- Surround sound, 26
- time alignment circuit, 11
- tweeter, 11, 36
 - mirror to inside, 17
 - offset, 13
- warranty, 9
- woofer, 10, 36
- XLR, 23

ALESIS LIMITED WARRANTY

ALESIS CORPORATION ("ALESIS") warrants this product to be free of defects in material and workmanship for a period of one year from the date of original retail purchase. This warranty is enforceable only by the original retail purchaser.

The purchaser should complete and return the enclosed warranty card within 14 days of purchase.

During the warranty period ALESIS shall, at its sole and absolute option, either repair or replace free of charge any product that proves to be defective on inspection by ALESIS or its authorized service representative. In all cases disputes concerning this warranty shall be resolved as prescribed by law.

To obtain warranty service, the purchaser must first call or write ALESIS at the address and telephone number printed below to obtain a Repair Order Number and instructions concerning where to return the unit for service. All inquiries must be accompanied by a description of the problem. All authorized returns must be sent to ALESIS or an authorized ALESIS repair facility postage prepaid, insured and properly packaged. Proof of purchase must be presented in the form of a bill of sale, canceled check or some other positive proof that the product is within the warranty period. ALESIS reserves the right to update any unit returned for repair. ALESIS reserves the right to change or improve design of the product at any time without prior notice.

This warranty does not cover claims for damage due to abuse, neglect, alteration or attempted repair by unauthorized personnel, and is limited to failures arising during normal use that are due to defects in material or workmanship in the product.

ANY IMPLIED WARRANTIES, INCLUDING IMPLIED WARRANTIES OF MERCHANTABILITY AND FITNESS FOR A PARTICULAR PURPOSE, ARE LIMITED IN DURATION TO THE LENGTH OF THIS LIMITED WARRANTY. Some states do not allow limitations on how long an implied warranty lasts, so the above limitation may not apply to you.

IN NO EVENT WILL ALESIS BE LIABLE FOR INCIDENTAL, CONSEQUENTIAL OR OTHER DAMAGES RESULTING FROM THE BREACH OF ANY EXPRESS OR IMPLIED WARRANTY, INCLUDING, AMONG OTHER THINGS, DAMAGE TO PROPERTY, DAMAGE BASED ON INCONVENIENCE OR ON LOSS OF USE OF THE PRODUCT, AND, TO THE EXTENT PERMITTED BY LAW, DAMAGES FOR PERSONAL INJURY. Some states do not allow the exclusion or limitation of incidental or consequential damages, so the above limitation or exclusion may not apply to you.

This warranty gives you specific legal rights, and you may also have other rights which vary from state to state.

This warranty only applies to products sold in the United States of America or Canada. The terms of this warranty and any obligations of Alesis under this warranty shall apply only within the country of sale. Without limiting the foregoing, repairs under this warranty shall be made only by a duly authorized Alesis service representative in the country of sale. For warranty information in all other countries please refer to your local distributor.

ALESIS
1633 26th Street
Santa Monica, California 90404
1-(800)-5-ALESIS
alecorp@alesis1.usa.com

**PLEASE SEND IN YOUR WARRANTY CARD
for faster, more effective service
and to receive product update notices**