



## S-Type Extended Battery Pack

### Installation Manual

Thank you for purchasing APC AV's S-Type Extended Battery Pack. Designed exclusively for the APC AV S15 Power Conditioner with Battery Backup, up to two SBATT Extended Battery Packs can be added to increase available battery runtime by 200%. Please register your product by filling out and mailing the enclosed Warranty Registration Card, or by registering online at [www.apcav.com](http://www.apcav.com).

**Notes on Battery Replacement:** Batteries contained within the SBATT are not user serviceable or replaceable. Contact your dealer, distributor, or APC to purchase another SBATT Extended Battery Pack.

The S15 performs an automatic Self-Test every two weeks by default. If the test fails, a Replace Battery message will appear on the S15's front display. To determine if it is the internal S15 battery pack or the external SBATT Extended Battery Pack that needs replacing, disconnect the SBATT and initiate a new Self-Test. If the test passes, the SBATT likely needs to be replaced. If in warranty, contact APC Technical Support (see below). If the test fails again, then the internal battery pack likely needs to be replaced. To initiate a Self-Test manually, press the Setup button on the front display until you reach the "Initate Self-Test" screen. Use the "up" or "down" arrows to initiate the test."

### SAFETY PRECAUTIONS

Please ensure you have read and understand all of the safety information located at the front of the S15 User's Manual. If you have any questions about the safety information, or are concerned that your home may not be properly wired for this equipment, please contact APC Technical Support or a qualified and licensed electrician.

Also note, this unit weighs 55 pounds. Two-person lift is required to install this device. Failure to comply may result in personal injury and/or equipment damage. Further, ensure the unit is place on a surface able to hold more than 55 pounds. If rack-mounting the unit, refer to the instructions provided with the mounting brackets and slide rails.

Do not install this device during a lightning storm. Do not dispose of this device by placing it in a fire. Please contact APC for information on the proper recycling and disposal of lead-acid batteries.

### Specifications

Item	Specification
Nominal Voltage	48 Vdc
Battery Quantity/Type	Eight 12-Volt, 9-Amp-Hour, Sealed Lead -Acid, Maintenance-Free Batteries
Battery Service	Not User-Serviceable
Battery Life	2-5 Years (Depending on use, environment, and temperature)
Battery Runtime:	1 SBATT + S15 batteries: <b>Full load:</b> 32 minutes. <b>Half load:</b> 81 minutes 2 SBATTs + S15 batteries: <b>Full load:</b> 62 minutes. <b>Half load:</b> 159 minutes <b>Note:</b> Actual runtimes are determined by load, battery charge level, battery health and quantity of batteries installed. Additional runtime can be achieved by adding a second SBATT unit to your system.
Unit Dimensions	17 x 3.5 x 18.55 in. (43.2 x 8.9 x 47.1 cm)
Unit Weight	55 lbs.
Warranty	The standard warranty is two (2) years from the date of purchase. APC's standard procedure is to replace the original unit with a factory reconditioned unit. Customers who must have the original unit back due to the assignment of asset tags and set depreciation schedules must declare such a need at first contact with an APC Technical Support representative. APC will ship the replacement unit once the defective unit has been received by the repair department, or cross-ship upon the receipt of a valid credit card number. The customer pays for shipping the unit to APC. APC pays ground freight transportation costs to ship the replacement unit to the customer.

### Contact Information

Internet Address:	<a href="http://www.apcav.com">www.apcav.com</a>
Email Support:	<a href="mailto:support.apcc.com">support.apcc.com</a>
Toll free:	(888) 88-APCAV
Address:	American Power Conversion 132 Fairgrounds Road West Kingston, RI 02892 USA

### S15 with 1 Extended Battery Pack

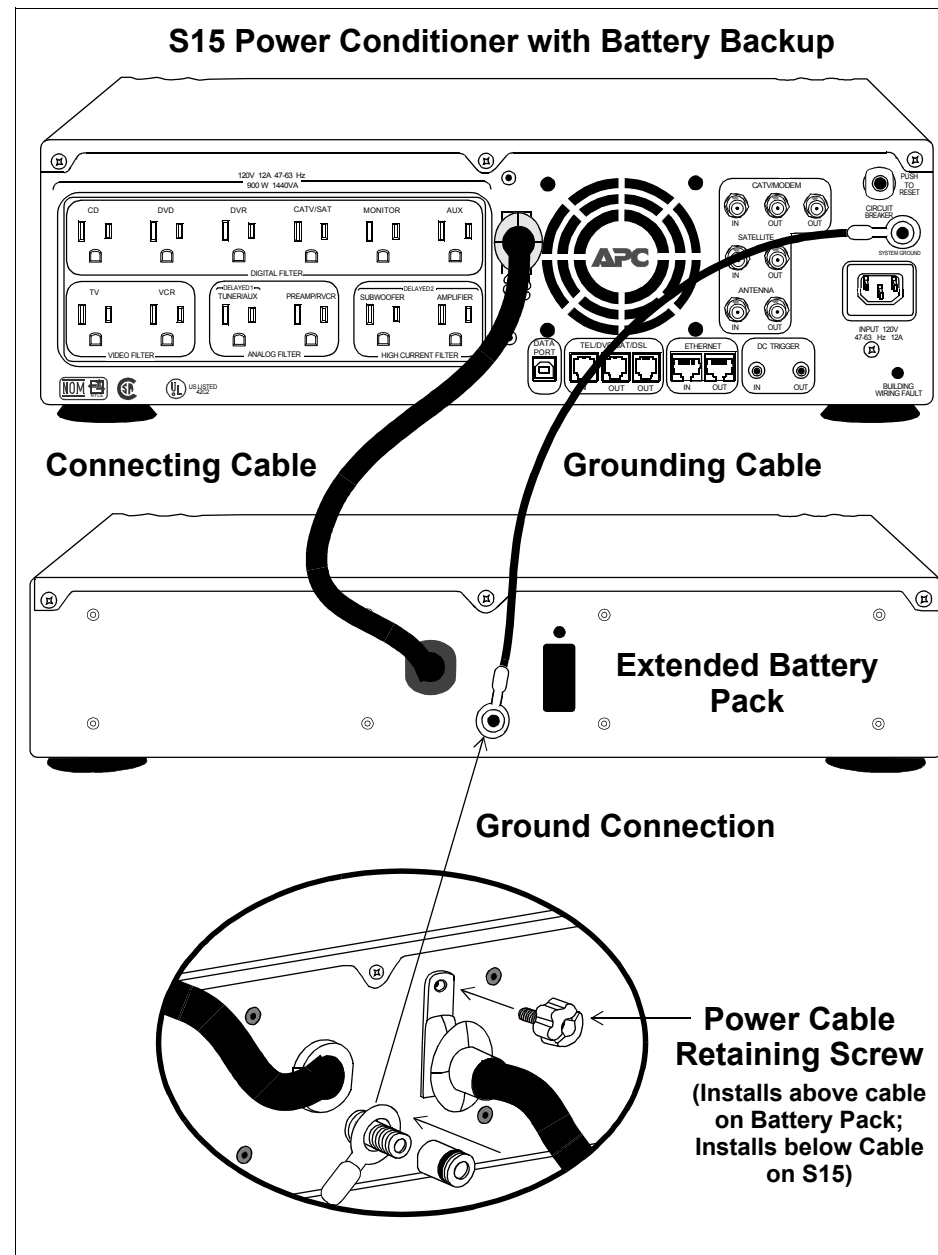

### S15 with 2 Extended Battery Packs

