

 **Albrecht.**[®]

Empire 2000

**AM/FM/SSB 200 CHANNELS
TRANSCIVER**

SPECIFICATIONS

TRANSMITTER SECTION

RF Power Output @ 13.8V DC.....	AM,FM:10W SSB:Up to 20 W PEP
AM Modulation Capability.....	+/-100%
FM Deviation	+/-1.5 KHz typical
Frequency Range	A:26.065 Through 26.505 MHz B:26.515 Through 26.955 MHz C:26.965 Through 27.405 MHz D:27.415 Through 27.855 MHz E:27.865 Through 28.305 MHz
Spurious Signal Suppression	Better than - 60 dB

RECEIVER SECTION

Sensitivity at 10 dB S+N/N	AM,FM:0.4 μ V, SSB:0.2 μ V
Image Rejection	80 dB
Squelch Sensitivity	Threshold:0.2 μ V Maximum (stop):500 μ V
Adjacent Channel Selectivity.....	Better than 70 dB
Cross Modulation	60 dB
Audio Output.....	5 Watts Peak
Audio Bandwidth (1KHz/0 dB) 3dB down	450 to 2000 Hz
"S" Meter Sensitivity for a reading of S9.....	100 μ V
Clarifier Frequency Range.....	+/-2.5 KHz
Power Source	Operates from nominal 13.8 Volts DC

DESCRIPTION

This model is an all-transistorize 2-way radio transceiver for mobile operation. A frequency synthesizer circuit provides crystal controlled PLL transmit and receive channels in the 27 MHz Band, engineered for trouble-free performance. Your transceiver uses heat resistant transistors in all critical areas. Current drain on 12 volts DC is exceptionally low. Operation over long periods is feasible even with your engine turned off. The transceiver may also be operated from A.C. when used with an optional Power Supply.

RECEIVER

The receiver is a sensitive and highly selective dual-conversion superheterodyne type providing crystal-controlled PLL operation on all 200 CB channels. The circuit incorporates an effective full time Automatic Noise Limiter in the audio stages. A ceramic filter provides sharp selectivity and high adjacent channel rejection. As a result, transmissions on adjacent channels cause minimum interference. A variable squelch control is incorporated to "silence" the receiver when no signals are being received. The squelch circuit is adjustable providing varying degrees of sensitivity to incoming signals.

TRANSMITTER

The transmitter offers crystal-controlled operation on all 200 CB channels, minimum DC power input to the final RF with average modulation capabilities is possible by the use of high-efficiency Transistors and low loss components, wiring, and mounting boards. The legal limit of power for this service is provided.

POWER SUPPLY

The transceiver is ready for connection to a 12 volt DC, negative or positive ground system. DC power is provided to the transceiver by means a fused power lead.

OPERATING CONTROL AND FEATURES

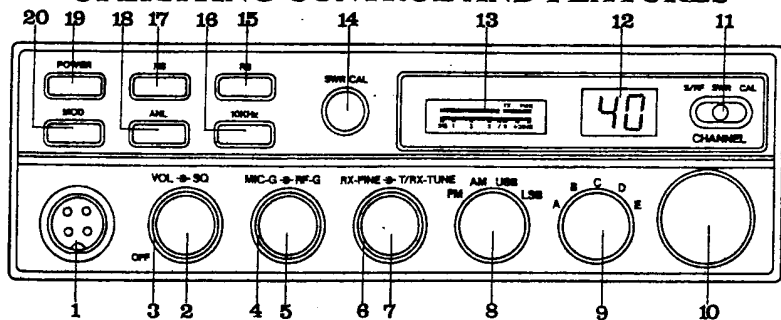

(1) MICROPHONE JACK

This jack accommodates the microphone connector, and is wired to provide transmit when microphone switch keyed.

(2) POWER ON OFF SWITCH VOLUME CONTROL

This switch turns transceiver power ON and OFF. Power is observed to be ON When the Channel Selector Dial and the Meter lights glow, and OFF when the lights are not illuminated and the transceiver fails to operate. Controls output from the built in external speaker connected to the "EXT SP" (rear of transceiver).

(3) SQUELCH CONTROL

The word "squench" means to silence; therefore the function of the control is silence the atmospheric noise (hash) usually present in all high frequency AM radio communication. The maximum "squench" is obtained when the control is in full CLOCKWISE position, minimum "squench" when in the COUNTERCLOCKWISE position.

(4) RF GAIN CONTROL SWITCH

This control is used to increase the sensitivity of the receiver so that distant stations may be received more clearly or to decrease the sensitivity so that very strong stations may be received more clearly.

(5) MICROPHONE GAIN CONTROL

This control provides the proper or desired modulation.

(6) RX FINE

This control provides an adjustment of TUNING-IN stations which are slightly OFF frequency, to optimize the AM and SSB reception.

(7) TRX TUNE

This control provides an adjustment of TUNING-IN stations which are slightly OFF frequency, to optimize the receiving Transmitting.

(8) FM. AM. USB. LSB MODE SELECTOR SWITCH

This selector enables the operator to select the mode of operation, FM or AM and upper or lower side band. The switch changed both the transmitter and the receiver.

(9) A. B. C. D. E BAND SELECTOR SWITCH

This switch selects the mode of operation, A: 26.065 ~ 26.505 MHz B: 26.515 ~ 26.955 MHz C: 26.965 ~ 27.405 MHz D: 27.415 ~ 27.855 MHz E: 27.865 ~ 28.305 MHz

(10) CHANNEL SELECTOR SWITCH

This Channel Selector sets the channel frequencies simultaneously for the receiving and transmitting modes. Refer to the PTT Rules and Regulations for complete information on the use of the various channels.

(11) S/R.F. SWR. CAL METER CONTROL SWITCH

This switch is used to select the scale to be read on the RF Power Meter. The switch has three positions : S/R.F (Signal/ Radio Frequency), CAL (Calibrate), SWR (Standing Wave Ratio).

(12) DIGITAL LED CHANNEL INDICATOR

LED (Light Emitting Diode) indicates the channel selected.

(13) S/R.F AND SWR LEVEL METER

At receive mode, This meter relate indication of signal strength. In the transmit mode, This meter relate indication of antenna RF Power and modulation and SWR Calibration.

(14) SWR CALIBRATION CONTROL

The Calibration Control provides (while keying transmitter) meter calibration adjustment enabling true standing wave ratio reference.

(15) ROGER BEEP SWITCH

Roger Beep tone on/off switch.

(16) +10 KHz SWITCH

This switch can be operated to shift +10KHz from TUNED selected channel or frequency in TX and RX.

(17) NOISE BLANKER SWITCH

NB circuits delete the noise in the IF AMP

(18) AUTOMATIC NOISE LIMITER SWITCH

When the switch to ANL Position, it reduces electrical Impulse noise, such as those caused by engine ignition system, etc.

(19) RF POWER SWITCH

This switch selects the transmit power HI and LOW

(20) MODULATION METER SWITCH

This switch is used to read the TX MODULATION DEGREE.

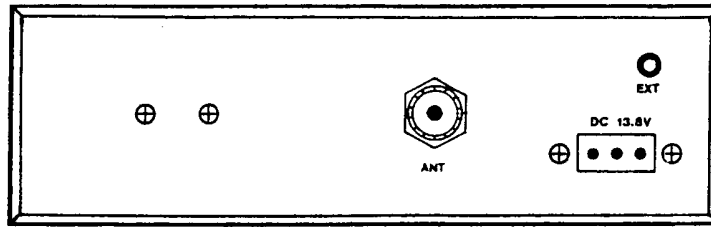

TRANSCEIVER INSTALLATION

MOUNTING

Always mount where controls are readily accessible, Unit may be mounted to the underside of the dashboard of a car, truck etc., utilizing special bracket included with transceiver.

Attach bracket to the underside of dashboard using the self-tapping screws supplied. Attach the transceiver to the bracket using the two knurled securing screws at the side. Tilt the unit to the most convenient angle before tightening securing screws.

DC POWER CONNECTION

With regard to the connection of the power cords, it may be possible or desirable to connect the red lead (for negative ground systems) or the black lead (for positive ground systems) to the ignition switch accessory terminal so that the radio is automatically turned off when the ignition switch (key) is turned off.

Alternately, the power lead may be connected to an available terminal on the fuse block or guard against a short circuit condition. When in doubt, please contact your vehicle dealer for specific information for your vehicle.

GROUND INFORMATION

Most newer U.S. and foreign made cars and small trucks use a negative ground system, while some older cars and some newer, larger trucks may use a positive ground system. A negative ground system is generally identified by the "-" battery terminal being connected to the vehicle motor block, but if you cannot determine the polarity of your vehicle, consult your vehicle dealer for information.

NOTE: This radio may be installed and used in any 12-volt DC negative or positive ground system.

NEGATIVE GROUND SYSTEM

If you are operating on a negative ground system, connect the red DC power cord from the radio to the positive "+" battery terminal or other convenient point and connect the black power lead to the chassis or vehicle frame, or the negative "-" terminal of the battery.

POSITIVE GROUND SYSTEM

If you are operating on a positive ground system, connect the black DC power cord from the radio to the negative "-" battery terminal or other convenient point and connect the red power lead to the chassis or vehicle frame, or the positive "+" terminal of the battery.

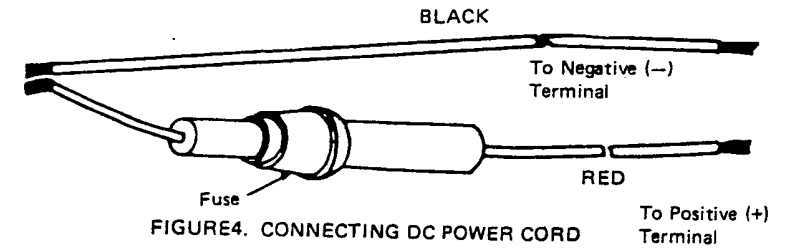

FIGURE 4. CONNECTING DC POWER CORD

ANTENNA CONNECTION

The lead-in cable from the CB antenna must be terminated with a PL-259 type male connector. Attach to the matching antenna input connector at the rear of the transceiver.

MICROPHONE BRACKET

Attach the microphone bracket provided to any convenient location.

MICROPHONE CONNECTION

Insert the 4 pin plug at the end of the coiled into the microphone socket.

DO NOT TRANSMIT WITHOUT AN ANTENNA CONNECTED TO THE TRANSCEIVER.

IGNITION INTERFERENCE

Normally the suppression on modern automotive engines is adequate to prevent annoying interference to your CB transceiver. If it does not, consult your dealer who will recommend additional suppression measurements.

RECEIVING

1. Select desired channel using the channel Selector Switch.
2. Rotate "SQUELCH" control to the extreme counter-clockwise position.
3. Rotate the "VOLUME/ON-OFF" switch clockwise, to apply power.
Operation will be instantaneous.
4. Set the "VOLUME/ON-OFF" switch clockwise to a comfortable listening level (approximately 1/3 setting). The receiver is now ready to operate.

SQUELCH ADJUSTMENT

The Squelch control eliminate annoying background noise in the absence of signals. To adjust the SQUELCH control properly turn up VOLUME until background noise is heard. Rotate the SQUELCH slowly clockwise until background noise just disappear. At this point the receiver will be quiet under "no signal" conditions, however a reasonable strength incoming signal will overcome the squelch action and be heard. As the control is advanced the squelch action is progressively increased and stronger incoming signals are needed to overcome it. To receive weak signals or to disable the squelch circuit turn the control fully counter clockwise.

EXTERNAL SPEAKER JACK

Recommended plug for the EXT SPEAKER jack is a "MINIPLUG" subminiature phone plug. The impedance of earphones or speakers connected should be 8-16 ohms. Insertion of a plug automatically silences the transceivers internal speaker.

SIGNAL STRENGTH LEVEL METER

When receiving, the S/RF LEVEL METER provides a relative indication of signal strength in "S" units providing a means of comparison between one received signal and another.

TRANSMITTING

To transmit, depress the push-to-talk button on microphone. The S/TX power LEVEL METER indicates the relative transmit power level. Use the microphone like a telephone speaking several inches from the face. Do not shout, use a normal speaking voice. When you are transmitting, the receiver is silenced and reception is, therefore, impossible. In the same way, your signal cannot be by another station when he is transmitting - each must take turns. To receive again, simply release the microphone push-to-talk button.

S/TX POWER LEVEL METER

In transmit position the S/TX POWER LEVEL METER gives a relative indication of antenna RF power.

AVAILABLE 27MHz FREQUENCIES

Your transceiver provides operation on all available U. S. Citizens Band channels. Frequencies are listed in accompanying table.

Frequency/Channel Chart

A Band		B Band		C Band		D Band		E Band	
Channel	MHz Frequency	Channel	MHz Frequency	Channel	MHz Frequency	Channel	MHz Frequency	Channel	MHz Frequency
1	26.065	1	26.515	1	26.965	1	27.415	1	27.865
2	26.075	2	26.525	2	26.975	2	27.425	2	27.875
3	26.085	3	26.535	3	26.985	3	27.435	3	27.885
4	26.105	4	26.555	4	27.005	4	27.455	4	27.905
5	26.115	5	26.565	5	27.015	5	27.465	5	27.915
6	27.125	6	26.575	6	27.025	6	27.475	6	27.925
7	26.135	7	26.585	7	27.035	7	27.485	7	27.935
8	26.155	8	26.605	8	27.055	8	27.505	8	27.955
9	26.165	9	26.615	9	27.065	9	27.515	9	27.965
10	26.175	10	26.625	10	27.075	10	27.525	10	27.975
11	26.185	11	26.635	11	27.085	11	27.535	11	27.985
12	26.205	12	26.655	12	27.105	12	27.555	12	28.005
13	26.215	13	26.665	13	27.115	13	27.565	13	28.015
14	26.225	14	26.675	14	27.125	14	27.575	14	28.025
15	26.235	15	26.685	15	27.135	15	27.585	15	28.035
16	26.255	16	26.705	16	27.155	16	27.605	16	28.055
17	26.265	17	26.715	17	27.165	17	27.615	17	28.065
18	26.275	18	26.725	18	27.175	18	27.625	18	28.075
19	26.285	19	26.735	19	27.185	19	27.635	19	28.085
20	26.305	20	26.755	20	27.205	20	27.655	20	28.105
21	26.315	21	26.765	21	27.215	21	27.665	21	28.115
22	26.325	22	26.775	22	27.225	22	27.675	22	28.125
23	26.335	23	26.805	23	27.255	23	27.705	23	28.155
24	26.335	24	26.785	24	27.235	24	27.685	24	28.135
25	26.345	25	26.795	25	27.245	25	27.695	25	28.145
26	26.365	26	26.815	26	27.265	26	27.715	26	28.165
27	26.375	27	26.325	27	27.275	27	27.725	27	28.175
28	26.385	28	26.835	28	27.285	28	27.835	28	28.185
29	26.395	29	26.845	29	27.295	29	27.845	29	28.195
30	26.405	30	26.855	30	27.305	30	27.755	30	28.205
31	26.415	31	26.865	31	27.315	31	27.865	31	28.215
32	26.425	32	26.875	32	27.325	32	27.775	32	28.225
33	26.435	33	26.885	33	27.335	33	27.785	33	28.235
34	26.445	34	26.895	34	27.345	34	27.795	34	28.245
35	26.455	35	26.905	35	27.355	35	27.805	35	28.255
36	26.465	36	26.915	36	27.365	36	27.815	36	28.265
37	26.475	37	26.925	37	27.375	37	27.825	37	28.275
38	26.485	38	26.935	38	27.385	38	27.835	38	28.285
39	26.495	39	26.945	39	27.395	39	27.845	39	28.295
40	26.505	40	26.955	40	27.405	40	27.855	40	28.305

TRANSCIVER SERVICING

Transceiver has been fully tested prior to shipment and will normally require further adjustments.