

LYMAN ACCUTRIMMER INSTRUCTIONS

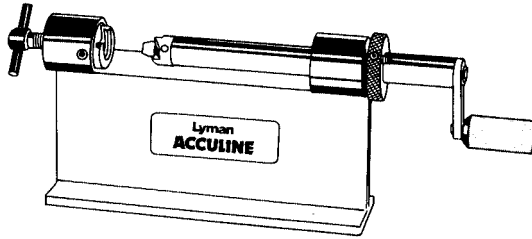

A metallic cartridge case will stretch after a number of firings and it then becomes necessary to trim it back to its proper length so it will chamber properly. The Lyman AccuTrimmer will accept most popular cases.

To convert to another caliber, you need only change to the proper size shellholder and pilot. Lyman offers a complete line of shellholders and pilots.

Mounting

The base of your trimmer is drilled with offset holes for mounting directly to the top of your reloading bench without splitting the wood. This is the recommended method of mounting. Some reloaders prefer to clamp their trimmer in a vise when using it. If the trimmer is to be used in this manner, Lyman recommends that it be fastened to a block of wood. The wooden block can then be held firmly in the vise jaws without damaging the base.

Installing The Cutter And Pilot

Thread the cutter onto the AccuTrimmer shaft until tight to the shaft. An easy method we use to ensure is to finger tighten the cutter to the shaft. Insert the hex head wrench into the pilot set screw and apply clockwise pressure on the handle while holding the wrench firmly. When tight, the cutter is secure and ready to use.

The pilot is inserted into the hole at the center of the cutter. Loosen the set screw with the wrench provided until the pilot sits flush to the cutter. Tighten the set screw. Use caution, as the cutter edges are extremely sharp. **IMPORTANT:** Use the proper pilot as specified for use with your cartridge case.



Preparing The Cases

Before trimming, cases must be full-length or neck resized and deprimed. Pilots are designed to be used with sized necks only.

Measuring The Cases

You will need an accurate means of measuring case length. We recommend Lyman precision calipers. When your cases have lengthened to the point where they exceed the maximum case length allowable for your cartridge, they must be trimmed. For a list of "maximum case lengths" and suggested "trim to lengths" see your Lyman handbook.

AccuTrimmer (continued)

Locking The Case In Place

Place the appropriate shellholder into the shellholder retainer slot.

Place your case into the shellholder. Slide the cutter shaft assembly, with the pilot installed in the cutter head, towards the case until the pilot enters the case mouth and push it in flush to the cutter head. Now, exerting slight pressure on the shaft, from the handle, tighten the case in place by turning the “T” handle clockwise until the case is tight. NOTE: Excessive pressure is not required. You are now ready to trim your case.

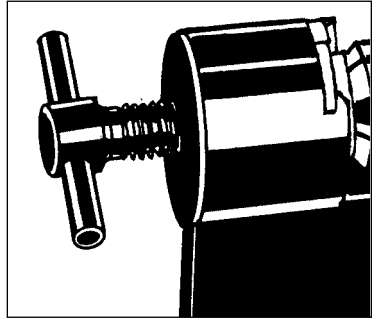

Adjusting The Cut

A knurled lock ring with a set screw through the side provide for both fine and coarse adjustments.

Advance the lock ring until it is close to the shaft bearing and tighten the set screw against the shaft with your hex wrench.

To adjust the fine cutting attachment, take your hex wrench and advance or retract the side set screw until you reach the trimming amount.

Hints

Adjust the cut a little at a time, checking your case length with your caliper after each cut. When the correct “trim to length” has been reached, you are now ready to begin processing all your cases.

Processing Your Cases

Once your AccuTrimmer is in adjustment, your entire lot of cases may be processed to bring them all to the correct length. As you turn the crank handle, keep an inward pressure on the cutter so that it is always bearing against the case mouth, but do not force it. After trimming, small burrs will be present on the case mouth. These can be easily removed from both inside and outside the case mouth with Lyman Deburring tools.

Keep a master case

When a reloader is working with several different calibers, it is wise to retain a master case of the correct length for each cartridge.

This reduces adjustment time since the master case can be snapped into the shellholder and the cutter quickly brought into adjustment against its mouth.

AccuTrimmer (continued)

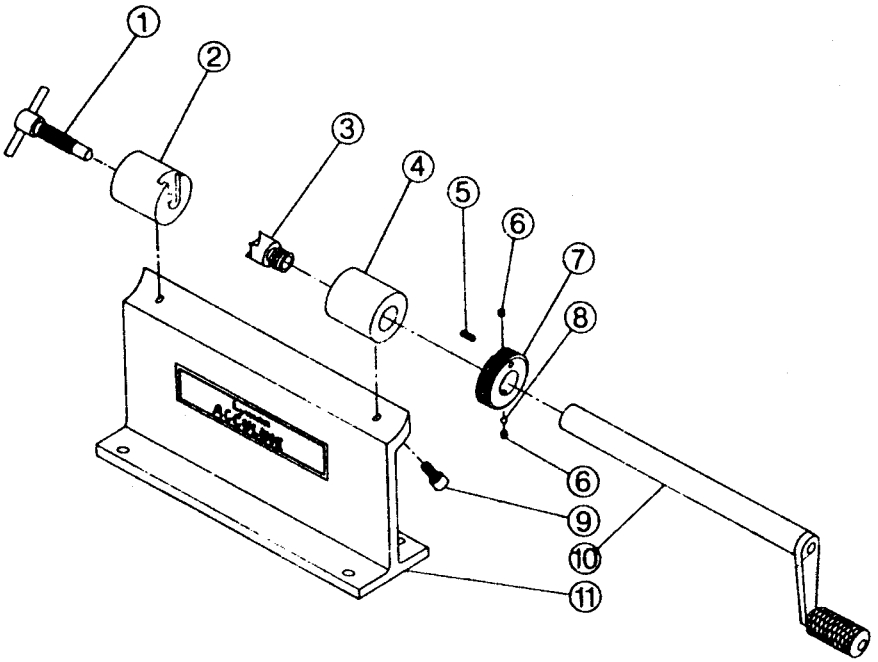

Key	Part Description	Part #	Key	Part Description	Part #
1	T-Handle Assembly	7993013	7	Adjustable Stop Collar	7993020
2	Shell Holder Retainer	7993003	8	Nylon Ball	7990076
3	Cutter Head Assembly	7822011	9	10-32 Socket Head Cap Screw (2)	7993006
4	Cutter Shaft Boss	7993005	10	Cutter Shaft Assembly	7994432
5	8-32 x 3/8 Set Screw	7993008	11	AccuTrimmer Base	7993018
6	8-32 x 1/8 Set Screw (2)	7994418			

**Visit our complete Lyman website at
www.lymanproducts.com**