



HI-STANDARD PISTOLS



PARTS PRICE LIST — .22 CALIBER MODELS

“Sport-King” “Flite-King” “Field-King” “Supermatic” “Olympic”

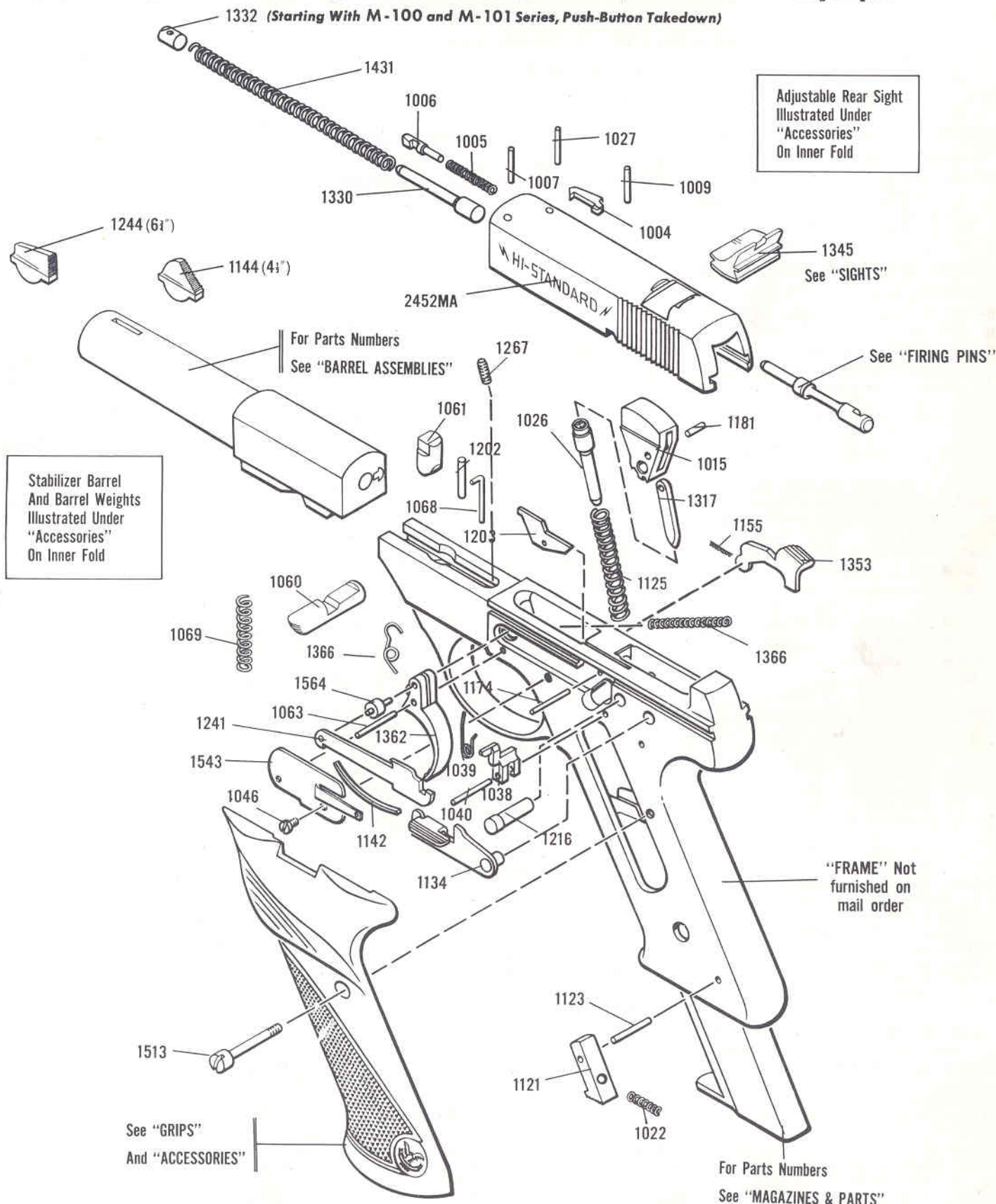

HI-STANDARD .22 CAL. SEMI-AUTOMATIC PISTOLS PARTS LIST AND PRICES

(Prices Subject to Change Without Notice)

(PUSH-BUTTON TAKE-DOWN MODELS)

SK — Sport-King

FLK — Flite-King

FK — Field-King

S — Supermatic

O — Olympic

Starting With Pistol Serial #443611

HOW TO ORDER REPAIR PARTS

The following information must be furnished when ordering replacement parts:

1. Model Name and Number
2. Serial Number
3. Number and Name of Parts.

PISTOL SHIPPING INSTRUCTIONS

BONAFIDE DEALERS IN FIREARMS are permitted by postal regulations to send pistols to the factory by Parcel Post. INDIVIDUALS are not permitted to mail firearms and we recommend shipment by railway express. All shipments to factory must be prepaid.

MINIMUM ORDER \$1.00

A minimum charge of \$1.00 is made on all orders where the normal cost would be less than \$1.00. If you wish, order extra parts to make up the minimum charge.

PAYMENT

All parts shipments will be made by Parcel Post C.O.D. unless advance remittance is made. PLEASE DO NOT SEND CASH OR STAMPS. Checks, Money Orders, or Drafts are acceptable and will save you C.O.D. charges.

FACTORY SERVICE

If parts are to be fitted at the factory, send pistols marked for the attention of our SERVICE DEPARTMENT, furnishing complete and specific repair instructions. A cost estimate of the parts and labor charges will be immediately sent for your approval before work is started.

Unless a flat rate charge is specified, a MINIMUM of \$6.50 will be charged on servicing pistols at the factory.

Part Number	Part Name	Model	Price Each
-------------	-----------	-------	------------

BARREL ASSEMBLIES

If ordering for a specific pistol, supply serial number. There is an extra charge of \$4.00 for fitting barrels at the factory.

1080-M	Barrel—Light—4½"	SK	12.50
1180-M	Barrel—Light—6¾"	SK	12.50
1281	Barrel—Nickel—4½"	SK	13.50
1381	Barrel—Nickel—6¾"	SK	13.50
1880-M	Barrel—Light—4½"	FLK	12.50
1980-M	Barrel—Light—6¾"	FLK	12.50
1280-M	Barrel—Medium—4½"	FK	13.50
1380-M	Barrel—Medium—6¾" (Stabilizer)	FK	17.50
1480-M	Barrel—4½" (Includes S filler plate #1092 & 2 screws #1093) *For Barrel Weights see below	S	18.50
1580-M	Barrel—6¾" (Includes S filler plate #1092 & 2 screws #1093) Stabilizer *For Barrel Weights see below	S	22.00
1680-M	Barrel—4½" (Includes O filler plate #1092 & 2 screws #1093) *For Barrel Weights see below	O	18.50
1780-M	Barrel—6¾" (Includes O filler plate #1092 & 2 screws #1093) Stabilizer *For Barrel Weights see below	O	22.00

BARREL WEIGHTS FOR SUPERMATIC AND OLYMPIC PISTOLS ONLY

1090-M	Barrel Weight—Heavy (3 oz.) (Includes 2 screws #1091)	S-O	2.25
1190-M	Barrel Weight—Light (2 oz.) (Includes 2 screws #1191)	S-O	2.25
1091	Barrel Weight Screws (For 3-oz. wt.)	S-O	.30
1191	Barrel Weight Screws (For 2-oz. wt.)	S-O	.30

Part Number	Part Name	Model	Price Each
-------------	-----------	-------	------------

GRIPS, GRIP SCREWS AND ESCUTCHEONS

We now have available American Walnut checkered grips, either plain, or with thumb rest for left hand or right hand (See illustrations under "Accessories").

WALNUT THUMBREST GRIPS (RIGHT HAND)

Sold only in matching pairs

1511-M	Left Side	SK-FLK-FK-S-O	
1512-M	Right Side		\$8.75 per pair

WALNUT THUMBREST GRIPS (LEFT HAND)

Sold only in matching pairs

1105-M	Left Side	SK-FLK-FK-S-O	
1104-M	Right Side		\$8.75 per pair

WALNUT GRIPS (WITHOUT THUMBREST)

Sold only in matching pairs

1107-M	Left Side	SK-FLK-FK-S-O	
1106-M	Right Side		\$8.00 per pair

PLASTIC THUMBREST GRIPS (RIGHT HAND ONLY)

1411-M	Left Side	SK-FLK-FK-S-O	1.75
1412-M	Right Side	SK-FLK-FK-S-O	1.75

(Above prices include escutcheons, screws and nuts when pairs of grips are ordered — specify model.)

FOR PLASTIC GRIPS

1513	Grip Screw	SK-FLK-FK-S-O	.30
1514	Grip Screw Nut	SK-FLK-FK-S-O	.30

FOR WALNUT GRIPS

1214	Grip Escutcheon	SK-FLK-FK-S-O	.30
1413	Grip Screw	SK-FLK-FK-S-O	.30
1414	Grip Screw Nut	SK-FLK-FK-S-O	.30

MAGAZINES

3038-M	Magazine	SK-FK-S	4.75
1418-M	Magazine (Beginning with #340000) (Olympic type maga- zine is for .22 shorts only)	O-FLK	5.75

Part Number	Part Name	Model	Price Each
-------------	-----------	-------	------------

PARTS

1524	Magazine Button	SK-FLK-FK-S-O	.30
1121	Magazine Catch	SK-FLK-FK-S-O	1.25
1123	Magazine Catch Pin	SK-FLK-FK-S-O	.30
1022	Magazine Catch Spring	SK-FLK-FK-S-O	.30
1219	Magazine Follower	SK-FK-S	.75
1419	Magazine Follower	FLK-O	1.25
1120	Magazine Spring	SK-FK-S	.60
1220	Magazine Spring	FLK-O	.60

SIGHTS FRONT

1144	Sight, Front 4½" Barrel	SK-FLK	1.25
1079	Sight, Front 4½" Barrel	FK-S-O	2.00
1079	Sight, Front 6¾" Barrel	FK-S-O	2.00
1244	Sight, Front 6¾" Barrel	SK-FLK	1.25
1744	Sight, Front (Used with the Adjustable Rear Sight #1147M)	SK	1.25
1093	Sight, Front, Set Screw	FK-S-O	.30
REAR			
1245	Sight, Rear Fixed	SK	1.50
1345	Sight, Rear Fixed	FLK	1.50
1147-M	Sight, Rear Adjustable	FK-S-O	7.50
1147-SK	Sight, Rear, Adjustable Kit (Includes #1147-M & #1744 front sight which is necessary to compensate for higher rear sight)	SK	8.75

NO ADJUSTABLE SIGHT MADE FOR
FLITE-KING MODEL

PARTS

1147	Sight, Rear Base	FK-S-O	2.75
1085	Sight, Rear Elevation Screw	FK-S-O	.30
1148	Sight, Rear Leaf	FK-S-O	3.50
1086	Sight, Rear Retaining Pin	FK-S-O	.30

CAUTION: FOR SAFETY'S SAKE DO NOT ATTEMPT TO REPAIR PISTOLS WITHOUT RECEIVING RELIABLE ADVICE

Part Number	Part Name	Model	Price Each
1087	Sight, Rear Spring	FK-S-O	.40
1084	Sight, Rear Windage Screw	FK-S-O	1.00

SLIDES

Slides are not considered interchangeable and should be fitted by a reliable gunsmith or at the factory. Olympic slides are for .22 Short cartridges only and cannot be used on .22 Long Rifle models.

1250	Slide Only (Nickel)	SK	15.00
1251	Slide Assembly (Nickel)	SK	19.00
2052	Slide Only (Includes Fixed Rear Sight #1245 & Wear Plug #1096)	SK	13.50
2052	Slide Assembly (Complete)	SK	17.60
2452	Slide Only (Includes Fixed Rear Sight #1345)	FLK	13.50
2452-M	Slide Assembly (Complete)	FLK	17.60
2152	Slide Only (Includes Wear Plug #1096 only)	FK	13.50
2152-M	Slide Assembly (Complete, but without Rear Sight)	FK	18.00
2252	Slide Only (Includes Wear Plug #1096 only)	S	13.50
2252-M	Slide Assembly (Complete, but without Rear Sight)	S	18.50
2352	Slide Only (Includes Wear Plug #1096 only)	O	13.50
2352-M	Slide Assembly (Complete, but without Rear Sight)	O	18.50

Part Number	Part Name	Model	Price Each
-------------	-----------	-------	------------

PARTS

1060	Barrel Plunger Cam	SK-FLK-FK-S-O	2.00
1061	Barrel Lock	SK-FLK-FK-S-O	1.00
1202	Barrel Lock Pin	SK-FLK-FK-S-O	.30
1068	Barrel Lock Retaining Pin	SK-FLK-FK-S-O	.30
1331	Driving Spring	SK-FK-S	.30
1431	Driving Spring	FLK-O	.30
1332	Driving Spring Plug	SK-FLK-FK-S-O	.30
1007	Driving Spring Plug Pin	SK-FLK-FK-S-O	.30
1330	Driving Spring Plunger	SK-FLK-FK-S-O	.70
1203	Ejector	SK-FLK-FK-S-O	.85
1174	Ejector Pin	SK-FLK-FK-S-O	.30
1004	Extractor	SK-FLK-FK-S-O	.75
1006	Extractor Plunger	SK-FLK-FK-S-O	.30
1027	Extractor Plunger Retaining Pin	SK-FLK-FK-S-O	.30
1005	Extractor Spring	SK-FLK-FK-S-O	.30
1092-M	Filler Plate (Short) including 2 screws	S-O	1.75
1097-M	Filler Plate (Long) including 2 screws	S-O	1.85
1093	Filler Plate Screw (2 required)	S-O	.30
1408	Firing Pin Nylon Sleeve Type (Beginning with #446445) (See "Note" below)	FK-S-O	2.00
1108	Firing Pin (See "Note" below)	SK-FLK-FK-S-O	1.25
1009	Firing Pin Retaining Pin	SK-FLK-FK-S-O	.30

Part Number	Part Name	Model	Price Each
1075	Firing Pin Sleeve, Front	FK-S-O	.30
1077	Firing Pin Sleeve, Rear	FK-S-O	.30
1078	Firing Pin Sleeve, Center	FK-S-O	.30
1015	Hammer	SK-FLK-FK-S-O	3.50
1216	Hammer Pin	SK-FLK-FK-S-O	.30
1026	Hammer Plunger	SK-FLK-FK-S-O	.75
1025	Hammer Spring	SK-FK-S	.30
1125	Hammer Spring	FLK-O	.30
1317	Hammer Strut	SK-FLK-FK-S-O	.75
1181	Hammer Strut Pin	SK-FLK-FK-S-O	.30
1134	Safety Lever	SK-FLK-FK-S-O	1.85
1038	Sear	SK-FLK-FK-S-O	2.75
1241	Sear Bar	SK-FLK-FK-S-O	.75
1142	Sear Bar Spring	SK-FLK-FK-S-O	.30
1040	Sear Pin	SK-FLK-FK-S-O	.30
1039	Sear Spring	FK-S-O	.30
1139	Sear Spring	SK-FLK	.30
1543	Side Plate	SK-FLK-FK-S-O	.50
1046	Side Plate Screw	SK-FLK-FK-S-O	.30
1353	Side Lock Lever	SK-FK-S	1.50
1453	Slide Lock Lever	FLK-O	1.50
1155	Slide Lock Spring	SK-FLK-FK-S-O	.30
1362	Trigger	SK-FLK-FK-S-O	2.50
1063	Trigger Pin	SK-FLK-FK-S-O	.30
1564	Trigger Pull Pin	SK-FLK-FK-S-O	.50
1366	Trigger Spring	SK-FLK-FK-S-O	.30
1267	Trigger Stop Screw	FK-S-O	.50
1069	Takedown Plunger Spring	SK-FLK-FK-S-O	.30
1096	Wear Plug	SK-FK-S-O	.50

Note: Firing Pin should not extend beyond cartridge headspace. See your gunsmith or return gun to factory.



ACCESSORIES

Accessories can give you greater shooting enjoyment and performance and add beauty and value to your Hi-Standard pistol.

American Walnut checkered grips — with thumb rest for right hand, left hand, or plain — may be ordered for all models at \$8.75 pair. The plastic grips on the Supermatic above show the thumb rest for right hand. American Walnut left-hand thumb-rest grips are shown in inset "A"; plain American Walnut grips in inset "B". Please specify parts numbers when ordering (see Price List under "Grips").

The 1147-M Adjustable Rear Sight on the gun above is available as an accessory for Sport-King (see Price List under "Sights, Rear"). It is standard on Olympic, Supermatic and Field-King, but not available for Flite-King.

The stabilizer barrel feature for reduced "muzzle-jump" in target shooting, illustrated above, is standard on Field-King, Supermatic and Olympic when ordered with 6¾-inch barrel. This feature may be installed on older models of Supermatic and Olympic with 6¾-inch barrels (see "Special Note" under "Barrel Assemblies"). Stabilizer target barrels, as on Field-King and Supermatic, can also be installed on Sport-King.

Quick-Change Conversion Kit lets you shoot both long rifles and shorts in your Supermatic, Olympic or Field-King. Balance, feel, grip, trigger pull, sighting all remain unchanged. Doubles your shooting enjoyment. No new serial number to be registered. Factory-fitted barrel, slide, barrel weights, magazine all included at about \$63.75, depending upon model. See your dealer or write for information.

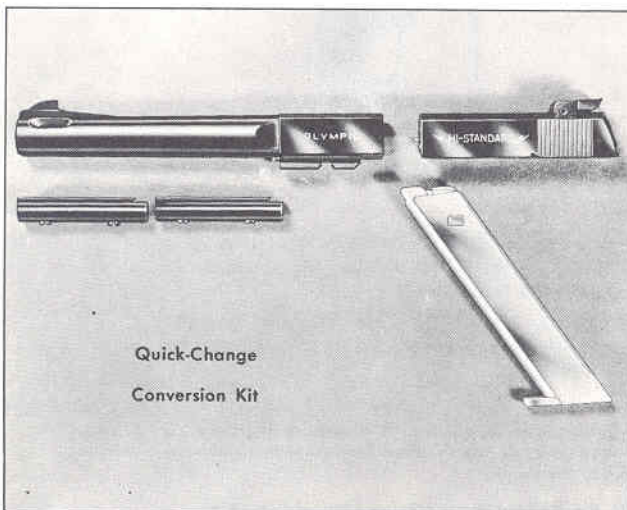

Quick-Change
Conversion Kit



INSTRUCTIONS FOR OPERATION AND CARE OF YOUR HI-STANDARD PISTOL



DISASSEMBLY: PUSH-BUTTON MODELS

NEVER ATTEMPT TO DISASSEMBLE BEFORE UNLOADING

1. Remove magazine by pressing catch and sliding magazine down and out of handle.
 2. Pull back slide and examine gun to be sure that no cartridge remains in the chamber.
 3. Move safety upward to ON position. This locks hammer so that it cannot be released by the trigger. It also locks slide onto frame so that slide cannot accidentally slip from frame when barrel is being removed.
 4. Grasp pistol as shown in Figure #1 and with the fingers braced against the slide, press the barrel plunger cam firmly with the thumb. While cam is pressed inward, slide the barrel off the front of frame with the other hand.
- The barrel plunger cam operates as a cam lock which is self tightening and is designed to take up any looseness between the barrel and the frame. If it is difficult to unlock with thumb pressure alone, proceed as follows:
- a. Release safety by pressing downward.
 - b. Grasp pistol as illustrated in Figure #2 and press thumb against barrel plunger cam at the same time. Pull slide backward and allow to snap forward against barrel. This shock

causes barrel plunger cam to unlock momentarily. If barrel is very tightly secured in the frame and removal is difficult, snap slide several times against the barrel breech while barrel plunger cam is depressed. This will drive barrel forward until it can be easily removed.

When removing right-hand grip, be careful not to lose Slide Lock Spring (see part number 1155 on front-page illustration).

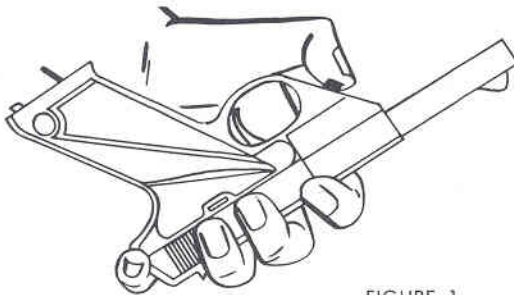

FIGURE 1

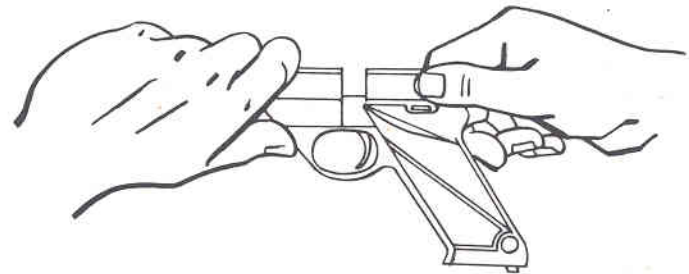

FIGURE 2

ASSEMBLY AND LOADING:

1. Replace slide by lining up with the grooves on the frame.
2. Hold as in Figure #1 and while depressing barrel plunger cam, slide barrel into position.
3. Push barrel backwards until barrel plunger cam locks it into position.
4. Push safety upward into ON position.
5. Load magazine by grasping it as shown in Figure #3, and gradually depress the magazine button as each cartridge is inserted — RIM END FIRST — through the front.

HI-STANDARD PISTOLS ARE FACTORY TESTED WITH ALL STANDARD BRANDS OF AMMUNITION.

6. Replace magazine into handle of pistol and secure in place with magazine catch. (Fully loaded Olympic and Flite-King magazines

will not lock into place unless slide is open.)

7. Release safety.
8. Grasp pistol in one hand and with the other pull the slide as far back as it will go. See Figure #4. Release slide and it will strip a cartridge from magazine and feed it into barrel chamber. Gun is now ready to fire by pulling trigger. THIS IS A SEMI-AUTOMATIC PISTOL AND TEN SUCCESSIVE SHOTS MAY BE FIRED BY SIMPLY PULLING THE TRIGGER FOR EACH SHOT.
9. Make gun safe. ALWAYS CARRY PISTOL WITH SAFETY ON — UNTIL READY TO USE. The safety is located at an accessible thumb-tip position so that it may be easily released when pistol is pointed at target. When loading into frame of pistol, be sure slide is locked in open position.

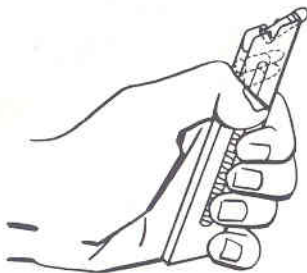
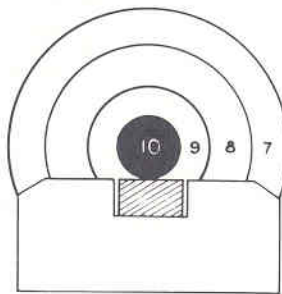

FIGURE 3



CORRECT SIGHT PICTURE

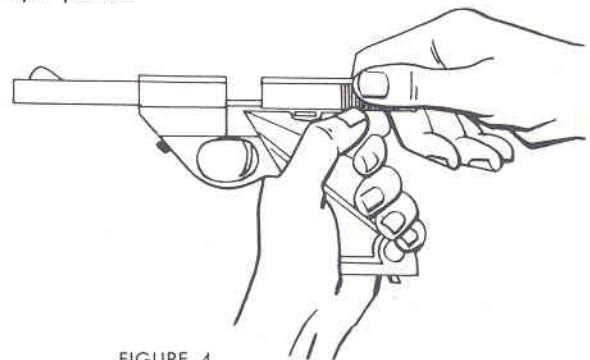

FIGURE 4

SIGHT ADJUSTMENT:

Sport-King and Flite-King pistols are sighted in at approximately a 50-foot range. If lateral adjustment is desired because of individual preferences in sighting or holding, tap the rear sight gently, using a brass or plastic hammer. Move the rear sight in the direction you want the point of impact to move.

Field-King, Supermatic, and Olympic Pistols are equipped with adjustable rear sights which permit a fine sight adjustment for target shooting at any range.

To elevate the point of impact (gun shooting low) turn the elevation adjustment screw in a clockwise direction. This screw is located on the top of the rear sight leaf. To remove point of impact to the left (gun shooting to right) turn windage adjustment screw in a clockwise direction. This screw is located on right side of rear sight base.

ALWAYS TURN ADJUSTMENT SCREWS ONE-QUARTER TURN AT A TIME, OR A MULTIPLE THEREOF, TO ALLOW THE MICROMETER "CLICK" ADJUSTMENT TO ENGAGE.

USE A SCREWDRIVER OF THE CORRECT SIZE TO AVOID DAMAGE WHEN MAKING SIGHT ADJUSTMENTS AND IN DISASSEMBLY OR ASSEMBLY OF THE PISTOL.

DRY FIRING:

In dummy firing the pistol in practice, it is best to first insert a dummy shell or fired case into the chamber. This will prevent damage to the firing pin and the barrel.

These guns will fire regular or hi-velocity .22 caliber ammo.

FOR TOP PERFORMANCE CLEAN STABILIZER AFTER EVERY 300 ROUNDS