

.357 Magnum Automatic Pistol
INSTRUCTION MANUAL

STOP

DO NOT USE GUN

READ

THIS BOOK FIRST

CAUTION :

USE OF
THIS GUN IS
DANGEROUS

Instruction Manual
for
COONAN .357 MAGNUM AUTOMATIC PISTOL

**READ THE INSTRUCTIONS
AND WARNINGS
IN THIS MANUAL
CAREFULLY AND COMPLETELY
BEFORE USING THIS FIREARM**

*This instruction manual should always accompany
this firearm and be transferred with it upon
change of ownership, or when the firearm is loaded
or presented to another person.*

*A copy of the instruction manual for this firearm
is available from the factory on request.
The instruction manual contains important
warnings which must be understood
before using this firearm.*

COONAN CUSTOM INC.
830 Hampden Ave.
St. Paul, MN 55114
(612) 646-0902

TABLE OF CONTENTS

| Section | Page |
|--|------|
| I Introduction | 1 |
| II Ammunition | 3 |
| III Handling | |
| a. Filling Magazine. | 4 |
| b. To Load, Chamber and Fire | 5 |
| c. To Uncock (Decock) | 8 |
| d. To Unload | 9 |
| IV Malfunctions ("Jams")..... | 10 |
| V Sights | 12 |
| VI Care of the Pistol | |
| a. Field Stripping (Disassembly). | 13 |
| b. Magazine Disassembly | 15 |
| c. Cleaning. | 16 |
| VII Service and Repair..... | 18 |
| VIII Specifications | 18 |
| IX Warranty | 19 |
| X Exploded Parts View. | 20 |
| XI Alphabetic Listing of Exploded Parts..... | 21 |
| XII Basic Rules of Safe Firearm Handling | 22 |
| XIII Cadet Breakdown and Assembly | 25 |

I. INTRODUCTION

FIREARMS SAFETY – YOUR RESPONSIBILITY

SAFETY MUST BE THE FIRST AND CONSTANT CONSIDERATION OF EVERY PERSON WHO HANDLES FIREARMS AND AMMUNITION.

This Instruction Manual is designed to assist you in learning how to use and care for your COONAN pistol properly.

Only when you are certain that you fully understand the Manual and can properly carry out its instructions should you practice loading, unloading, etc. with live ammunition.

If you have any doubts about your ability to handle or use a particular type of gun safely, you should seek supervised instruction.

Such personalized instruction is often available from gun dealers, gun clubs or police departments. If none of these sources can help you, write to the National Rifle Association, 1600 Rhode Island Avenue N.W., Washington, D.C., 20036. They will assist you.

The person with a gun in his possession has a full-time job. He cannot guess; he cannot forget. He must know how to use his firearm safely. Do not use any firearm without having a complete understanding of its particular characteristics and safe use. There is no such thing as a foolproof gun.

WARNINGS OF GREAT IMPORTANCE ARE FOUND ON THE FOLLOWING PAGES:

| | | | |
|-----------------------------|----|-----------------------|----|
| Alteration | 2 | Handling | 7 |
| Ammunition | 3 | Decocking | 8 |
| Eyesight | 3 | Unloading | 9 |
| Bore Obstructions | 4 | Malfunction | 10 |
| Firing | 6 | Recoil Plug | 13 |
| Half Cock | 7 | Lubrication | 17 |
| Parts Purchasers | 18 | | |

Other cautions and warnings appear on the cover, the title page and the following pages:
2, 3, 5, 6, 9, 11, 12, 13, 15, 16, 17, 20, 23, 24, 25.

FIREARMS ARE DANGEROUS WEAPONS –
READ THE INSTRUCTIONS AND WARNINGS
IN THIS MANUAL THOROUGHLY AND
CAREFULLY BEFORE USING THE
COONAN SEMI-AUTOMATIC PISTOL.

ALTERATION WARNING

Coonan Custom, Inc. will not be responsible for any alteration of any part of this firearm after it leaves our control, or for the addition or substitution of parts or accessories not manufactured by Coonan Custom, Inc. This product was designed to function properly in its original condition. Any changes made in this product are specifically contrary to our instructions and we expressly do not authorize any changes to be made after manufacture. Do not jeopardize your safety or the safety of others by making modifications to your firearm.

CAUTION

Careless handling of this pistol could result in unintentional discharge causing injury, death, or damage to property.

READ THIS MANUAL COMPLETELY BEFORE USING THE PISTOL.

NOTE

Throughout these instructions the names of parts have been CAPITALIZED. This was done to permit easy recognition from the parts list and exploded view. See pages 21 and 22.

II. AMMUNITION

The COONAN .357 Magnum Semi-Automatic Pistol is designed to use only caliber .357 Magnum ammunition manufactured in accordance with U. S. Industry Standards.*

AMMUNITION WARNING

Firearms may be damaged and death or serious injury to the shooter or other persons may result from any condition which contributes to the generation of excessive pressure or the uncontrolled release of gas within a firearm. The foregoing adverse conditions can be caused by bore or chamber obstructions, propellant powder overloads or by defective, incorrect or improperly loaded and assembled cartridge components.

It is extremely dangerous to use a cartridge whose pressure is greater than that developed by cartridges loaded to Industry Standards. Even the strongest firearm can be blown up as a result of excessive pressure.

NOTICE

WE SPECIFICALLY DISCLAIM RESPONSIBILITY FOR ANY DAMAGE OR INJURY WHATSOEVER OCCURRING IN CONNECTION WITH, OR AS A RESULT OF, THE USE IN THE COONAN PISTOL OF FAULTY, OR NON-STANDARD, OR "RE-MANUFACTURED", OR HAND LOADED (RELOADED) AMMUNITION, OR OF CARTRIDGES OTHER THAN THOSE FOR WHICH THE FIREARM WAS ORIGINALLY CHAMBERED.

As with any semi-automatic pistol, some rounds perform better than others.

EYESIGHT WARNING

Cartridge cases are made of a relatively soft and thin metal, and must contain high pressure. A burst or leaky case could release gas or fragments of metal which could injure the shooter's eyes. Therefore, **always wear shooting glasses or protective eyewear.**

.38 SPECIAL

.38 special ammunition may not cycle until unit is broken in (approximately 200 rounds.)

The 12 pound spring supplied with the unit may require removal of coils, depending on the power of .38 special ammunition used.

We recommend using .38 +P ammunition in the Model "B" COONAN.

*Industry standards are established by SAAMI - Sporting Arms and Ammunition Manufacturers Institute.

III. HANDLING

BORE OBSTRUCTIONS WARNING

Before loading or firing the pistol, examine the bore to be certain it is clear and unobstructed. Firing the pistol with any obstruction in the bore – even a heavy coating of oil or drops of water – may result in damage to the gun and injury to the shooter and other persons nearby.

A misfire or unusual report (sound) upon firing is always a signal to cease firing and immediately examine the chamber and bore. If there is any obstruction, full or partial, clear the obstruction with a cleaning rod and bore brush before firing the gun.

a. FILLING MAGAZINE

The magazine holds seven (7) rounds of .357 Magnum ammunition.

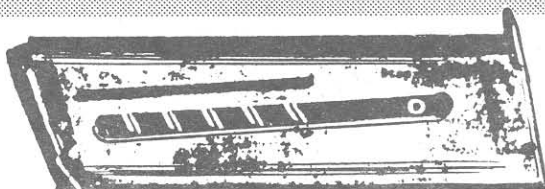

1. Insert **MAGAZINE LOADING PIN** through hole in **MAGAZINE FOLLOWER**.

2. Depress **FOLLOWER** until it bottoms out.

3. Hold **FOLLOWER** in this position and:

- insert seven cartridges, base first between front and rear magazine lips one at a time.
- allow them to fall to rest atop **FOLLOWER**.

4. **CAUTION:** When using the **MAGAZINE LOADING PIN**, have it under control. Do not pull it down and release it suddenly. Release **MAGAZINE PIN** gradually and allow **FOLLOWER** to rise.

5. Inspect top cartridge to ensure bullet is pointing forward and is tilted upward.

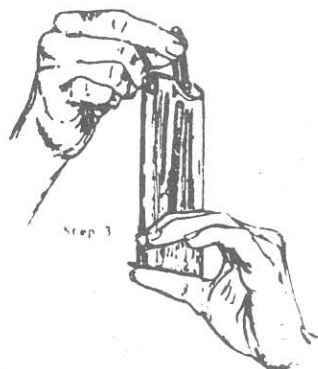

The magazine may also be loaded without the aid of the **MAGAZINE LOADING PIN**. To do so, follow these instructions:

1. Place cartridge base down on top of follower between front and rear magazine lips (See Step 3 illustration) and press down firmly.

2. When cartridge has been pushed down about 3/8" below the rear feel lips, push the nose of the cartridge down through the front feed lips. Holding the **MAGAZINE FOLLOWER PIN** with your finger will aid in this process.

b. TO LOAD, CHAMBER AND FIRE

LOADING:

CAUTION

READ THIS SECTION COMPLETELY AND THOROUGHLY
BEFORE ATTEMPTING ANY OPERATIONS.

KEEP PISTOL POINTED IN A SAFE DIRECTION.

KEEP FINGER OFF TRIGGER.

1. Pull SLIDE to the rear – inspect chamber to be sure chamber is empty.
2. Insert MAGAZINE into magazine well in base of grip. Push upward until MAGAZINE CATCH engages.

NOTE

Do not attempt to bend magazine lips.
The metal has been heat treated and may crack.

3. Push SLIDE CATCH down, allowing the SLIDE to move freely forward under its own power. Do not hold back movement of the SLIDE as this may result in a mis-feed or jam.

..CAUTION..

THE PISTOL IS NOW LOADED AND READY TO FIRE.

4. Push THUMB LOCK up until it is positively engaged if pistol is not to be fired immediately. Push THUMB LOCK down when ready to fire. ALWAYS KEEP FINGERS OFF THE TRIGGER WHEN MOVING THE THUMB LOCK UP (ENGAGED) OR DOWN (DISENGAGED).
5. If you wish to load and chamber a cartridge WITHOUT using the MAGAZINE, follow the procedure below, remembering to use all of the cautions listed above.
 - A. Pull SLIDE fully rearward and engage SLIDE CATCH to hold the slide open.
 - B. Insert a cartridge in the chamber.

C. While holding the SLIDE with one hand and the FRAME with the other, disengage slide catch by pushing it down. Allow slide to close slowly. The EXTRACTOR must ride over the rim of the cartridge in order for the SLIDE to fully close. If it does not, pull the SLIDE back about 1/2" and release it. This should allow the EXTRACTOR to ride over the rim and close the SLIDE. Pushing the rear end of the EXTRACTOR in will also allow the EXTRACTOR to override the cartridge rim.

..CAUTION..

THE PISTOL IS NOW LOADED AND READY TO FIRE.

NOTE: CLOSED BREECH

The MAGAZINE FOLLOWER has been adjusted so you can now load a full seven (7) round clip under a closed breech. The Coonan now has an eight (8) round capacity.

FIRING WARNING

When firing the pistol, be sure that other shooters and bystanders are well clear of the shooter and a safe distance to the rear. Empty cartridge cases are ejected from the pistol with some velocity and could cause injury to any person who is standing in their path. Left-handed shooters should be particularly cautious concerning ejected cartridge cases and powder. All shooters should wear shooting glasses or protective eyewear when firing the COONAN pistol.

The SLIDE of the semi-automatic pistol moves rearward forcefully and at high speed when the gun is fired. Do not position your face, hands or any part of your body so the SLIDE can strike you when the gun is fired.

SPECIAL NOTE ON "SAFETIES"

There are two forms of what are commonly called "safeties". There is nothing safe about a firearm, so to make explanations perfectly clear, they are not called "safeties", but:

"LOCKING DEVICES".

1. A GRIP LOCK is designed so the pistol has to be held firmly and the GRIP LOCK depressed in order for the HAMMER to be released by the SEAR and TRIGGER.
2. A THUMB LOCK is located just above the GRIP LOCK at the left side of the FRAME. It must be lowered in order to fire the pistol.

HALF-COCK WARNING

Although the HAMMER has a half-cock position, this is NOT a "SAFETY". Its purpose is to act as a backup for the SEAR and provide insurance that the pistol will not go into an uncontrollable automatic fire. It also provides that should the HAMMER slip during cocking, the firing pin will not be struck.

HANDLING WARNING

Do not load the pistol until you are ready to use it, and unload it immediately when you have completed shooting. (See also UNLOADING WARNING in this manual.)

Exercise utmost care and caution at all times when handling any firearm. The firearm should be carried and handled so that it will not be dropped or struck. With the THUMB LOCK off (in the down position), the pistol is in the ready-to-fire mode. Therefore, as with any firearm, any blow or jar which is of sufficient force to actuate components of the firing mechanism (trigger or hammer or sear or firing pin) may cause a chambered cartridge to discharge. Such a discharge can occur with or without the trigger being directly struck or touched.

When carrying the pistol with a loaded magazine in place, the chamber should be empty and the SLIDE should be closed.

DO NOT CARRY THE PISTOL WITH THE CARTRIDGE IN THE CHAMBER!

Do not carry a loaded pistol with the THUMB LOCK in the down position! The user should never depend on a safety mechanism or any mechanical device to justify careless handling or permitting the pistol to point in an unsafe direction. The shooter should always be alert to the possibility of accidental discharge regardless of the position of the THUMB LOCK. The only safe pistol is one in which the SLIDE is open, the chamber is empty, and there is no magazine in the gun.

FIRING:

1. Aim pistol at intended target.
2. Grip firmly, depressing GRIP LOCK.
3. Slowly pull trigger to the rear.

c. TO UNLOCK (DECOCK)

If the pistol is cocked and you want to let the hammer down, proceed as follows:

DECOCKING WARNING

Never attempt to decock a gun without performing the following steps to remove the MAGAZINE and clear the chamber! Keep the gun pointed in a safe direction at all times!

1. Remove MAGAZINE.
2. Grip the SLIDE and pull all the way back. When SLIDE is all the way back, push the SLIDE CATCH up while allowing the SLIDE to return forward. This will allow the SLIDE CATCH to hold the SLIDE open and back and eject any cartridge that may be in the chamber.
3. With the SLIDE held open and back by the SLIDE CATCH, check the chamber to ensure that it is empty. Check the chamber again to ensure that it is empty.
4. After ensuring that the chamber is empty, allow the SLIDE to return to the closed position by pushing down on the SLIDE CATCH.
5. When the MAGAZINE has been removed, the chamber cleared, the gun cocked and the SLIDE closed, follow this procedure to decock:
 - a. Grip pistol as if shooting so GRIP LOCK is engaged.
 - b. Place thumb or index finger of opposite hand between HAMMER and SLIDE.
 - c. Slowly pull TRIGGER to the rear, releasing the HAMMER.
 - d. This permits HAMMER to fall against thumb.
 - e. Slowly pull thumb out, allowing HAMMER to drop slowly.
 - f. Remove finger from trigger.

d. TO UNLOAD

NOTE

THE MAGAZINE IS HELD IN THE PISTOL UNDER SPRING TENSION. PLACE HAND BENEATH MAGAZINE TO CATCH IT AS IT IS RELEASED. DO NOT ALLOW IT TO DROP ON HARD SURFACES.

1. Depress the MAGAZINE CATCH.
2. Pull SLIDE fully to rear and manually engage SLIDE CATCH.
3. Check the chamber to ensure that it is empty.

UNLOADING WARNING

Removing the magazine from the pistol does not prevent the pistol from being fired! When there is a cartridge in the chamber and the THUMB LOCK is "off", the cartridge will discharge if the trigger is pulled. It is absolutely essential for the user of a semi-automatic pistol to know how to completely unload it.

"Completely" means first removing the magazine and then removing a chambered cartridge. The THUMB LOCK should always be "on" or in the "up" position when unloading the pistol.

IV. MALFUNCTIONS ("JAMS")

MALFUNCTION WARNING

The .357 Magnum cartridge has its sensitive priming compound in the primer in the center of the head of the cartridge case. It is fired by impacting of the firing pin against the relatively soft primer which detonates the priming compound. Any crushing of the primer can cause a cartridge to be 'discharged' before it is chambered if the primer receives a sharp blow from any source. For that reason, the user of a firearm must regard any jam or feeding problem as a signal to immediately stop using the gun until it can be determined what is wrong.

If a cartridge hangs up, jams, or binds when being hand chambered or when being fed from the magazine into the chamber, do not attempt to force it into the chamber by pushing or striking the slide.

Most failures of a cartridge to feed or to chamber are caused by a damaged magazine, improper gun handling or defective ammunition.

Whatever the cause, the gun user must, above all, recognize that cartridge jams can result in the very potentially dangerous situation of a cartridge discharging before it is chambered. If this occurs, the cartridge case will rupture and its fragments will fly out of the gun with sufficient force to cause injury.

Always wear shooting glasses or protective eyewear!

1. Be certain the muzzle is pointed in a safe direction and the THUMB LOCK is in the "off" or "down" position.
2. If possible, first remove the MAGAZINE. It may be necessary to manually remove a jammed cartridge which has only partially been stripped from the MAGAZINE from the gun. If so, use extreme care. Lock the SLIDE open with the SLIDE CATCH before attempting to clear the jam. Drawing the SLIDE fully to the rear may bring the jammed cartridge along. KEEP YOUR FACE AWAY FROM THE EJECTION PORT DURING THIS OPERATION. When attempting to clear a jam, use only wood 'tools' so that a cartridge will not be ignited and so that the chamber and magazine will not be damaged. A 3/16" wood dowel rod with a point on one end is useful for clearing jams.
3. Visually check to make sure all cartridges have been removed from the pistol. Safely dispose of any cartridges involved in a malfunction incident. Do not use damaged ammunition in any firearm.
4. If it appears that the gun and magazine are not at fault and that the jam was caused by the type of cartridge being used, then try another type.

5. If changing to another type or brand of cartridge does not at once result in smooth feeding of cartridges from magazine to chamber, then the following steps should be taken:
 - a. Make certain the gun and the magazine are unloaded and that the thumb lock is in the "off" or "down" position. Remember, the magazine should be removed first, then check the chamber to be certain it and the magazine-well are clear of cartridges.
 - b. Thoroughly clean the magazine, paying particular attention to removing accumulated grease. Thoroughly clean the breech mechanism of the firearm. Use a bristle brush and solvent to remove grease and fouling from the breech face, the extractor, the chamber and the feed ramp. (See Part VI of this Manual for disassembly and cleaning instructions.)
 - c. Check to see that the magazine spring tension is adequate.
 - d. Check the magazine lips to be certain they are free of nicks and burrs and are not deformed.

NOTE

Do not attempt to bend magazine lips.
The metal has been heat treated and may crack.

- e. Remove excess oil and solvent from all cleaned components, load the magazine and try the firearm again. As always, proceed slowly. Be certain bystanders are not close and that you are wearing protective eyewear and your face is a safe distance from the pistol, so that any discharge incident resulting from a jammed cartridge will not injure anyone.

If the above procedures do not result in a smooth and reliable feeding firearm, don't use the gun until it feeds cartridges smoothly and reliably. The pistol can be returned directly to the factory for repair. See Part VII of this manual for packing and shipping.

Another precaution: When using any firearm, form the habit of examining fired cartridge cases from time to time. If fired cases frequently show splits or bulges on any part of the case, the pistol should be returned to the factory for inspection.

V. SIGHTS

The pistol has a rear sight that may be adjusted for windage by shifting left or right. Moving the sight to the right moves the point of impact to the right.

Adjustment is made by loosening the allen head screw, moving sight and retightening screw. A wrench for this purpose has been included with this pistol.

Adjustment for elevation requires cutting down front sight or replacing it with a taller one. The task is best accomplished by a competent gunsmith.

NOTE

Model B Front Sight Replacement

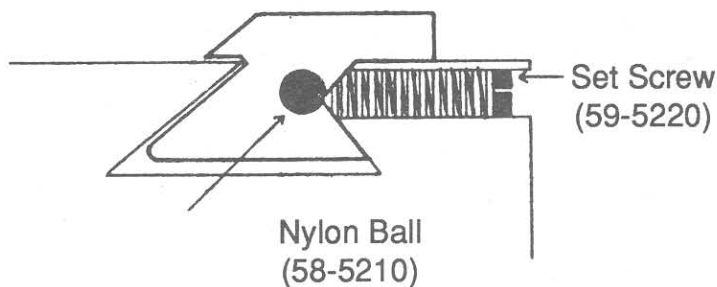

When replacing front sight and/or nylon ball, place ball in detent in sight and insert sight in slide. Use a clamp or vise to keep sight tight against top of slide. Use a small amount of Loctite in the set screw hole. Turn the set screw in and wipe off excess Loctite from inside slide and around sight. This should keep the sight in place.

VI. CARE OF THE PISTOL

Warning: Never clean, lubricate, disassemble, assemble or work on a firearm while it is loaded.

a. Field Stripping (Disassembly)

Disassembly of the COONAN .357 Magnum is easy and follows quite closely the guidelines of the original military M 1911.45 automatic.

NOTE

Never use force when disassembly is necessary.

See EXPLODED PARTS VIEW (Page 21) for names and location of parts.

••CAUTION••

Always check to be positive pistol is unloaded
before disassembly is started.
CHECK AND CHECK AGAIN.

Take parts from gun one at a time and lay in order in front of you left to right. Reassembly will be much easier now by simply reversing the following procedure:

1. Remove MAGAZINE. Pull SLIDE to the rear and engage SLIDE CATCH. Inspect chamber to ensure that it is empty.
2. Release SLIDE CATCH and allow SLIDE to go fully forward.
3. Point pistol away from your or any bystander's face. Then push RECOIL PLUG inward with index finger or blunt object. Keeping RECOIL PLUG pushed inwards, turn BARREL BUSHING to the left (counter-clockwise as viewed from front) until RECOIL PLUG is free to move forward.

MALFUNCTION WARNING

The RECOIL PLUG is under heavy spring tension. If released, it can spring out of the firearm and cut the face or injure the eyes of the person handling the firearm or a bystander. Release the tension on the RECOIL PLUG slowly so that it does not pop out. Keep pistol pointed away from your or any bystander's face.

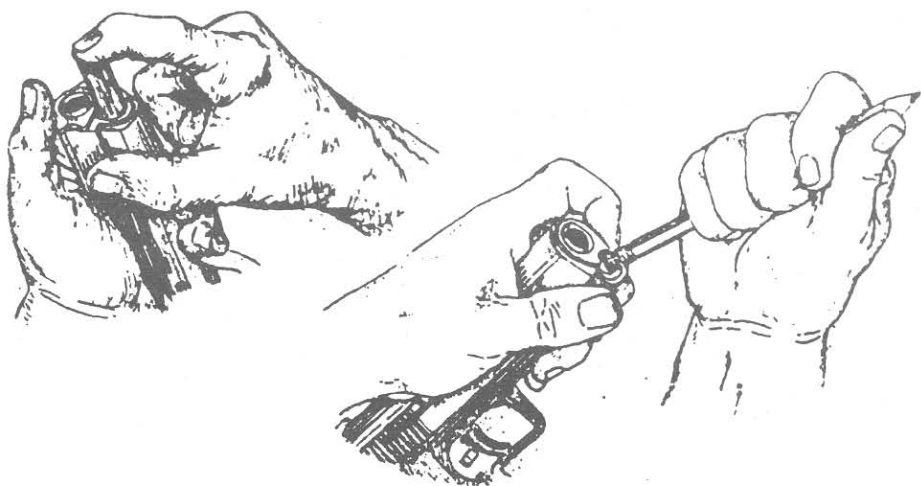

4. Pull SLIDE back until disassembly notch on slide lines up with rear end of SLIDE CATCH. The SLIDE CATCH is able to pass under the slide and out of the frame only at this point. Push against the end of the SLIDE CATCH which projects from the opposite side of the receiver, above the trigger guard. With SLIDE CATCH pushed to its fully downward position, withdraw catch.



5. Move SLIDE forward, removing SLIDE, BARREL and BARREL LINK, BARREL BUSHING, RECOIL SPRING and RECOILSPRINGPLUNGER TUBE.
6. Remove the SPRING and PLUNGER TUBE.
7. Push BARREL forward approximately 1/4". Turn the BARREL BUSHING to the right (counter-clockwise as viewed from the front) as far as it will go and withdraw it forward from the slide.
8. Tilt the BARREL LINK forward and withdraw the BARREL from the SLIDE.

The Model "B" COONAN has a linkless barrel system.

REASSEMBLY IS IN REVERSE ORDER OF ASSEMBLY.

Tips on reassembly:

After the BARREL, BARREL BUSHING and associated parts are reassembled into the SLIDE, run the slide onto the frame. Continue to move to the rear until the hole in the BARREL SLIDE CATCH through SLIDE, through BARREL LINK and out hole on right side of SLIDE. Make sure SLIDE CATCH is snapped into place under slide assembly notch in SLIDE.

NOTE

BARREL will not lock unless
SLIDE CATCH is through LINK.

Reassemble RECOIL SPRING, RECOIL PLUG, AND BARREL BUSHING.

** CAUTION **

Keep pistol pointed away from your or any bystander's faces when depressing RECOIL PLUG and SPRING

b. Magazine Disassembly

1. With blunt object, depress round disassembly button (part of MAGAZINE WEDGE).

2. Slide MAGAZINE FLOOR PLATE forward and out of MAGAZINE BODY.

3. Withdraw MAGAZINE WEDGE and MAGAZINE SPRING.

4. Slide MAGAZINE FOLLOWER down until MAGAZINE FOLLOWER PIN reaches large opening in side of MAGAZINE BODY.

5. With blunt object, push PIN through FOLLOWER and clear of body.

6. Allow FOLLOWER to drop free of body.



NOTE

MAGAZINE SPRING has small loop at bottom.

c. CLEANING

NOTE

Most malfunctions of pistols (semi-automatic handguns) are directly attributed to lack of cleaning.

..CAUTION..

Always check to be positive pistol is unloaded before cleaning or disassembly is started.

CHECK AND CHECK AGAIN!

1. Disassemble pistol as described on Page 13.
2. From the chamber end of the barrel, run a cleaning rod with solvent soaked patch through several times.
3. Using a .38/.357 caliber brush, push through the bore several times.
4. With a .38/.357 "chamber" brush, clean the chamber end of the barrel.
5. Wipe the cleaning rod and using a dry patch, swab the bore (changing patches as necessary) until patches come out clean.
6. Inspect the bore to ensure it is clean and free of obstruction.
7. All other parts and the outside of the barrel should be cleaned with a solvent soaked cloth, and wiped with any oily cloth if gun is to be stored.

NOTE

In very cold climates, use special low temperature lubricants or dry lubricants such as graphite.

NOTE

For the first 500 rounds, use lithium grease on slide, frame rails and the barrel surfaces.

LUBRICATION WARNING

Firing a pistol with oil, grease or any other material even partially obstructing the bore may result in damage to the pistol and injury to the shooter and those nearby.

Do not spray or apply lubricants directly on ammunition or a loaded magazine, or allow cartridges to rest on an oil-soaked cloth. If the powder charge of a cartridge is affected by the lubricant, it may not be ignited, but the energy from the primer may be sufficient to push the bullet into the bore where it may become lodged. Firing a subsequent bullet into the obstructed bore may damage the pistol and cause injury to the shooter and those nearby. Use lubricants properly. You are responsible for the proper care and maintenance of your firearm.

NOTE

DO NOT ALLOW GRIPS TO BECOME SOAKED IN SOLVENT OR LUBRICANT.

NOTE

The stainless steel surfaces of the pistol may discolor due to contact with certain chemicals used in curing leather. A light coating of lubricant or hard paste wax will prevent this from occurring.

VII. SERVICE/REPAIR

Should your COONAN .357 MAGNUM require adjustment or repair, it must be taken or sent to the factory.

1. Make sure pistol and magazine are empty.
2. Carefully pack in original shipping box or in a well padded container.
3. Include a full written description of the problem. Go into as much detail as possible. To this description add your name, address, telephone number and the serial number of the pistol.
4. Ship by UPS (or other legal method)* prepaid to the factory.
NOTE: No freight collect shipments will be paid by the factory.
5. INSURE FOR FULL VALUE AGAINST LOSS OR THEFT.

WARNINGS TO PARTS PURCHASERS

It is the purchaser's responsibility to be absolutely certain that any parts ordered from the factory are correctly fitted and installed. Firearms are complicated mechanisms and IMPROPER FITTINGS OF PARTS MAY RESULT IN A DANGEROUS MALFUNCTION, DAMAGE TO THE FIREARM, AND INJURY TO THE SHOOTER AND OTHER PERSONS. The purchaser and installer of parts must accept full responsibility for the correct adjustment and functioning of the pistol after such installation.

*Check with your dealer if in doubt on method of shipment.

VIII. SPECIFICATIONS

Weight: 42.0 oz./1.19kg - empty with magazine
48.0 oz./1.36 kg - loaded with 7 rounds

Length: 8.3 in/210.8mm overall

Width: 1.3 in/33 mm maximum

Height: 5.6 in/142.2 mm

Barrel Length: 5.0 in/127 mm

Magazine Capacity: 7 rounds

Specifications subject to change without notice.

IX. WARRANTY

WHY NO WARRANTY CARD HAS BEEN PACKED WITH THIS NEW COONAN FIREARM

The Magnuson-Moss Act (Public Law 93-637) does not require any seller or manufacturer of a consumer product to give a written warranty. It does provide that if a written warranty is given, it must be designated as "limited" or as "full" and sets minimum standards for a "full" warranty.

Coonan Custom, Inc. has elected not to provide any written warranty, either "limited" or "full", rather than to attempt to comply with the provisions of the Magnuson-Moss Act and the regulations issued thereunder.

There are certain implied warranties under state law with respect to sales of consumer goods. As the extent and interpretation of these implied warranties varies from state to state, you should refer to your state law.

Coonan Custom, Inc. wishes to assure its customers of its continued interest in providing service to owners of Coonan firearms.

NOTE

*If this pistol is sold or transferred,
this manual should accompany it.*

COONAN .357 MAGNUM AUTOMATIC is a registered trademark.

The entire contents of this manual are copyrighted (1982) by Coonan Arms, Inc. and may not be reproduced without their written consent.

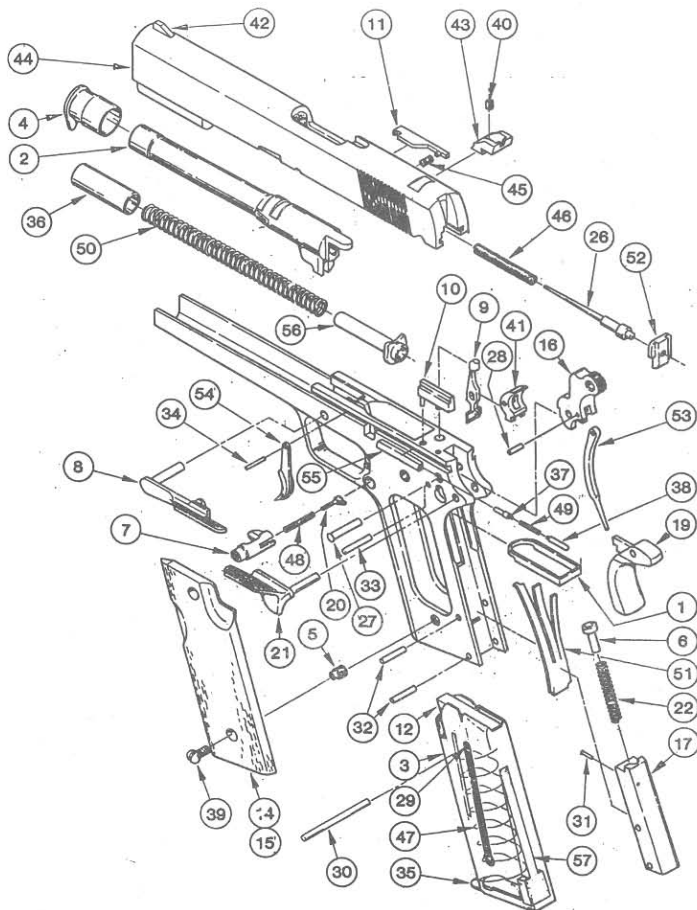

- | | | | | | |
|----|---------------------|----|-------------------------|----|-----------------------------|
| 1 | Bar, Trigger | 20 | Lock, Magazine Catch | 40 | Screw, Rear Sight |
| 2 | Barrel | 21 | Lock, Thumb | 41 | Sear |
| 3 | Body, Magazine | 22 | Mainspring | 42 | Sight, Front |
| 4 | Bushing, Barrel | 25 | Pin, Extractor | 43 | Sight, Rear |
| 5 | Bushing, Grip Screw | 26 | Pin, Firing | 44 | Slide |
| 6 | Cap, Mainspring | 27 | Pin, Hammer | 45 | Spring, Extractor |
| 7 | Catch, Magazine | 28 | Pin, Hammer Strut | 46 | Spring, Firing Pin |
| 8 | Catch, Slide | 29 | Pin, Magazine Follower | 47 | Spring, Magazine |
| 9 | Disconnecter | 30 | Pin, Magazine Loading | 48 | Spring, Magazine Catch |
| 10 | Ejector | 31 | Pin, Mainspring Cap | 49 | Spring, Plunger Tube |
| 11 | Extractor | 32 | Pin, Mainspring Housing | 50 | Spring, Recoil |
| 12 | Follower, Magazine | 33 | Pin, Sear | 51 | Spring, Sear |
| 13 | Frame | 34 | Pin, Trigger | 52 | Stop, Firing Pin |
| 14 | Grip, Left Hand | 35 | Plate, Magazine Floor | 53 | Strut, Hammer |
| 15 | Grip, Right Hand | 36 | Plug, Recoil | 54 | Trigger |
| 16 | Hammer | 37 | Plunger, Slide Stop | 55 | Tube, Plunger |
| 17 | Housing, Mainspring | 38 | Plunger, Thumb Lock | 56 | Tube, Recoil Spring Plunger |
| 19 | Lock, Grip | 39 | Screw, Grip | 57 | Wedge, Magazine |

ALPHABETIC LISTING OF EXPLODED PARTS

| | | | |
|---------------------------------|-----------|--------------------------------------|-----------|
| Barrel | 2 - 1100 | Magazine loading pin | 30 - 6600 |
| Barrel bushing | 4 - 1200 | Magazine spring | 47 - 6400 |
| Barrel link | 18 - 1300 | Magazine wedge | 57 - 6300 |
| Barrel link pin | 23 - 1400 | Mainspring | 22 - 3200 |
| Disconnecter | 9 - 1500 | Mainspring cap. | 6 - 3300 |
| Ejector | 10 - 1600 | Mainspring cap pin | 31 - 3400 |
| Ejector pin | 24 - 1700 | Mainspring housing | 17 - 3500 |
| Extractor | 11 - 1800 | Mainspring housing pin | 32 - 3600 |
| Extractor pin | 25 - 1900 | Nylon ball | 58 - 5210 |
| Extractor spring | 45 - 2000 | Plunger tube | 55 - 4400 |
| Firing pin | 26 - 2100 | Plunger tube spring | 49 - 4100 |
| Firing pin spring | 46 - 2300 | Rear sight | 43 - 5300 |
| Firing pin stop | 52 - 2200 | Rear sight screw | 40 - 5301 |
| Frame | 13 - 5500 | Recoil plug | 36 - 3700 |
| Front sight | 42 - 5200 | Recoil spring | 50 - 3900 |
| Grip lock | 19 - 2400 | Recoil spring plunger tube | 56 - 3800 |
| Grip screw bushing | 5 - 5800 | Right hand grip | 15 - 3600 |
| Hammer | 16 - 2500 | Sear | 41 - 4400 |
| Hammer pin | 27 - 2600 | Sear pin | 33 - 4500 |
| Hammer strut | 53 - 2700 | Sear spring | 51 - 4600 |
| Hammer strut pin | 28 - 2800 | Set screw | 59 - 5220 |
| Left hand grip | 14 - 5700 | Slide | 44 - 5400 |
| Magazine body | 3 - 6000 | Slide catch | 8 - 4700 |
| Magazine catch | 7 - 2900 | Slide stop plunger | 37 - 4200 |
| Magazine catch lock | 20 - 3000 | Thumb lock | 21 - 4800 |
| Magazine catch spring | 48 - 3100 | Thumb lock plunger | 38 - 4300 |
| Magazine floor plate | 35 - 6500 | Trigger | 54 - 4900 |
| Magazine follower | 12 - 6100 | Trigger bar | 1 - 5100 |
| Magazine follower pin | 29 - 6200 | Trigger pin | 34 - 5000 |

Please use complete part number and description when ordering.
Example: 2-1100 Barrel.

XII. THE BASIC RULES OF SAFE FIREARMS HANDLING*

We believe Americans have a right to purchase and use firearms for lawful purposes. The private ownership of firearms in America is traditional, but that ownership imposes the responsibility on the gun owner to use his firearms in a way that will ensure his own safety and that of others. When firearms are used in a safe and responsible manner, they are a great source of pleasure and satisfaction, and represent a fundamental part of our personal liberty.

Firearms do not cause accidents! Firearms accidents are almost always found to have been the result of carelessness or ignorance on the part of the shooter of the basic rules of safe gun handling.

The following rules must be observed by gun users at all times. Safe gun handling is not just desirable, it is absolutely essential to the continuation of gun ownership and sport shooting as we know it today.

1. LEARN THE MECHANICAL AND HANDLING CHARACTERISTICS OF THE FIREARM YOU ARE USING. Not all firearms are the same. The method of carrying and handling firearms varies in accordance with the mechanical provisions for avoiding accidental discharge and the various proper procedures for loading and unloading. No person should handle any firearms without first having thoroughly familiarized himself with the particular type of firearm he is using, and with safe gun handling in general.

2. ALWAYS KEEP THE MUZZLE POINTED IN A SAFE DIRECTION. Be sure of the bullet stop behind your target, even when dry-firing. Never let the muzzle of a firearm point at any part of your body or at another person. This is particularly important when loading or unloading a firearm. In the event of an accidental discharge, no injury can occur as long as the muzzle is pointing in a safe direction. A safe direction means a direction that will not permit a discharged bullet to strike a person, or to strike an object from which the bullet can ricochet. A safe direction must take into account the fact that a bullet may penetrate a wall, ceiling, floor, window, etc., and strike a person or damage property. Make it a habit to know exactly where the muzzle of your gun is pointing whenever you handle it, and be sure that you are always in control of the direction in which the muzzle is pointing, even if you fall or stumble.

3. FIREARMS SHOULD BE UNLOADED WHEN NOT IN USE. Firearms should be loaded only when you are in the field or on the target range or shooting area, ready to shoot. Firearms and ammunition should be securely locked in racks or cabinets when not in use. Ammunition should be safely stored separate from firearms. Store your firearms out of sight of visitors and children. It is the gun owner's responsibility to be certain that

children and persons unfamiliar with firearms cannot gain access to firearms or ammunition.

4. **BE SURE THE BARREL IS CLEAR OF OBSTRUCTIONS BEFORE SHOOTING.** Even a bit of mush, snow or excess lubricating oil or grease in the bore may cause the barrel to bulge or even burst on firing, and cause injury to the shooter and bystanders. Be sure you are using ammunition of the proper caliber and loading for the gun you are using. If the report or recoil on firing seems weak or doesn't seem quite right, **CEASE FIRING IMMEDIATELY** and check to be sure no obstruction has become lodged in the barrel.

5. **BE SURE OF YOUR TARGET BEFORE YOU SHOOT.** Don't shoot unless you know exactly where your bullet is going to strike. Be sure of the bullet stop behind your target, even when dry-firing with an unloaded gun. If you are in the field hunting, do not fire at a movement or noise. Take the time to absolutely certain of your target before you pull the trigger.

6. **WEAR PROTECTIVE EYEWEAR AND HEARING PROTECTORS WHEN YOU SHOOT.** All shooters should wear shooting glasses or protective eyewear and some form of hearing protectors when shooting. Exposure to shooting noise can damage hearing. Adequate vision protection when shooting is essential.

7. **NEVER CLIMB A TREE OR FENCE WITH A LOADED FIREARM.** Put the firearm down carefully before climbing a fence, and unload it before climbing or descending a tree or jumping over a ditch or other obstruction. Never pull or push a loaded firearm toward yourself or another person. When in doubt, unload your gun!

8. **DON'T SHOOT AT A HARD SURFACE, OR AT WATER.** Bullets can glance off many surfaces, like rocks or the surface of water, and travel in unpredictable directions with considerable velocity.

9. **NEVER TRANSPORT A LOADED FIREARM.** Firearms should always be unloaded before being placed in a vehicle. A suitable carrying case or scabbard should be used to carry a firearm to and from the shooting area.

10. **AVOID ALCOHOLIC BEVERAGES WHEN SHOOTING.** Don't drink until the day's shooting is over. Handling firearms while under the influence of alcohol in any form constitutes a criminal disregard for the safety of others.

* Reprinted courtesy of Sturm Ruger & Company Inc.

FIREARMS ARE DANGEROUS WEAPONS –

**READ THE INSTRUCTIONS AND WARNINGS
IN THIS MANUAL THOROUGHLY AND
CAREFULLY BEFORE USING THE
COONAN SEMI-AUTOMATIC PISTOL.**

This instruction manual should always accompany this firearm and be transferred with it upon change of ownership, or when the firearm is loaned or presented to another person.

The instruction manual contains important warnings which must be understood before using this firearm.

A copy of the instruction manual for the firearm is available from the factory upon request at a minimal cost.

XIII. CADET BREAKDOWN AND ASSEMBLY

BREAKDOWN

1. Pull slide (5) back until disassembly notch (6-half circle) is lined up with rear end of slide catch (9). Push slide catch out from the other side of frame while pulling on it from the front.
2. Pull slide back further until hole in extended spring guide (1) is visible. Insert paper clip or other object of similar diameter into hole.
3. Pull slide forward and off.
4. Remove spring guide (1), spring (2), and recoil plug (3) from rear of slide (8-spring tunnel).
5. Remove barrel from front after spring guide (1), spring (2) and recoil plug (3).

ASSEMBLY

1. Insert barrel.
2. Install spring guide (1), spring (2) and recoil plug (3) assembly through rear of spring tunnel (8). NOTE: Plug should be pushed into tunnel before installing on frame.
3. Install slide assembly on frame.
4. Pull slide back until barrel is no longer visible in slide catch hole.
5. Insert slide catch (9).
6. Pull slide back further until disassembly notch (6) is lined up with rear end of slide catch (9).
7. Push slide catch (9) in and down until it snaps into place.
8. Remove paper clip and release slide forward.
9. Extended spring guide (1) will be protruding from end of muzzle. Insert enclosed hex key (allen wrench) into the end of guide and turn. When snapped in place it should be flush with muzzle.
10. If guide does not snap in place, pull back slide and release. Repeat step nine.

CADET ASSEMBLY

1. Extended Spring Guide
2. Spring
3. Recoil Plug
4. Paper Clip
5. Slide
6. Disassembly Notch (half circle)
7. Hex Key Notch
8. Spring Tunnel
9. Slide Catch
10. Rear End of Slide Catch- 11. Paper Clip Hole

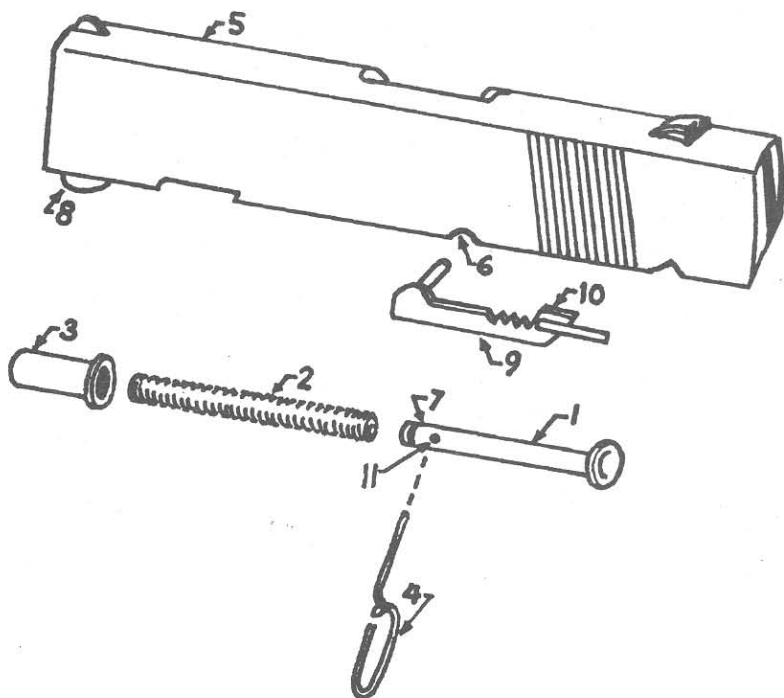



840 HAMPDEN AVE. ST. PAUL MN 55114 • 612/646-0902