

BRINKMANN®

**MAXFIRE®
XENON**

**DUAL XENON™
RECHARGEABLE**

OWNER'S MANUAL & OPERATING INSTRUCTIONS

⚠ WARNING

READ AND FOLLOW ALL WARNINGS AND INSTRUCTIONS IN THIS MANUAL TO AVOID PERSONAL INJURY OR PROPERTY DAMAGE.



IMPORTANT SAFETY WARNINGS

⚠ READ AND FOLLOW ALL SAFETY WARNINGS AND INSTRUCTIONS IN THE OWNER'S MANUAL BEFORE OPERATING SPOTLIGHT.

⚠ WARNING

- Never place spotlight face down when light is on or is still hot from recent use. Doing so could burn/ignite surfaces such as seats, carpeting, etc. and cause major property damage. Always turn spotlight off when not in use.
- To prevent serious damage to eyesight, never look into spotlight when light is on. Do not shine light into the face of someone else.
- Do not touch lens of spotlight when light is on or if it was recently on. The lens will be hot and could cause serious burns.
- Do not place spotlight in water. Keep all components dry and out of water at all times.
- Do not allow children to handle or operate this spotlight.
- Do not use this product for other than its intended use.
- Do not operate in close proximity of combustible or flammable materials.
- Do not attempt to operate spotlight if cord, plug, bulb or any part of the spotlight is damaged or corroded.
- Only use AC charger and DC lighter plug that are provided with the Dual Xenon spotlight or their replacements.
- A damaged battery can leak acid. Avoid contact with eyes and skin. If contact occurs, flush immediately with large amounts of water. DO NOT ingest. If contact with eyes or ingestion occurs, consult physician immediately.

USE CAUTION AND COMMON SENSE WHEN OPERATING YOUR SPOTLIGHT.

**FAILURE TO ADHERE TO THE SAFETY WARNINGS AND GUIDELINES IN THIS MANUAL
COULD RESULT IN BODILY INJURY OR PROPERTY DAMAGE.**

SAVE THIS MANUAL FOR FUTURE REFERENCE.

OPERATING INSTRUCTIONS

⚠ READ AND FOLLOW ALL SAFETY WARNINGS AND INSTRUCTIONS IN THE OWNER'S MANUAL BEFORE OPERATING SPOTLIGHT.

Inspect contents of the box to ensure all parts are included and undamaged.



Step 1: Depress trigger switch in handle to turn spotlight ON.

Step 2: Release trigger switch to turn spotlight OFF.

Continuous Beam Using Lock Button:

Step 1: For a continuous beam, depress trigger switch and slide the lock button to the LOCKED position.

Step 2: To unlock and turn spotlight OFF, slide the lock button to the UNLOCKED position.

NOTE: To lock the Dual Xenon in the OFF position, release trigger switch, then slide the lock button to the LOCKED position.

⚠ WARNING: Always turn spotlight off when not in use.

Switching Between Single and Dual Beams:

Step 1: For single beam, slide switch on back of light to one dot, as illustrated.

Step 2: For dual beam, slide switch on back of light to two dots, as illustrated.

NOTE: The Dual Xenon will burn for approximately 40 minutes if using both beams, or approximately 85 minutes if using only one beam.

Step 1: Make sure trigger switch is not locked in the ON position.

Step 2: Plug the AC charger or DC charger/adapter into the socket located on the base of the spotlight handle as illustrated.

Step 3: For DC Charger/Adapter:

Plug the other end of the DC charger/adapter into a cigarette lighter receptacle.

For AC Charger:

Plug the other end of the AC charger into a wall outlet.

Parts List

- ① Dual Xenon spotlight
 - ② 120-volt AC charger
 - ③ 12-volt DC charger/adapter lighter plug
- Owner's Manual

To Operate

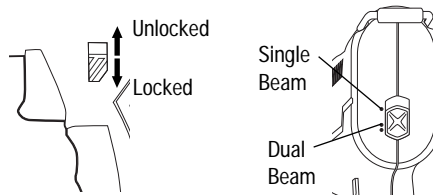
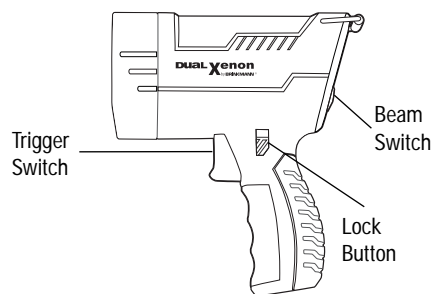

To Charge

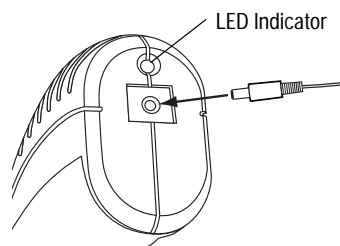



IMPORTANT: The EPA Certified RBRC® Battery Recycling Seal on the lead acid (Pb) battery contained in our product indicates The Brinkmann Corporation is voluntarily

participating in an industry program to collect and recycle these batteries at the end of their useful life, when taken out of service in the United States or Canada. The RBRC® program provides a convenient alternative to placing used Pb batteries into the trash or the municipal waste stream, which may be illegal in your area. Please call 1-800-8-BATTERY™ for information on Pb battery recycling and disposal bans/restrictions in your area. The Brinkmann Corporation's involvement in this program is part of our commitment to preserving our environment and conserving our natural resources.

To Replace Bulb

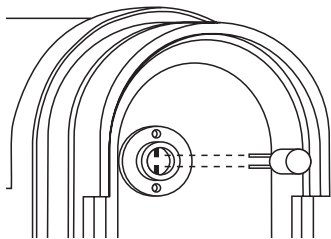
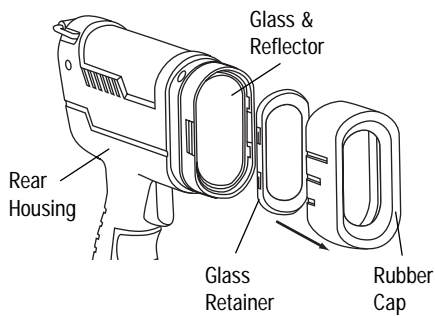

Step 4: Allow the spotlight to charge for at least 8 hours. Do not allow to charge more than 12 hours.

Note: LED indicator on base of handle turns off automatically when battery is fully charged.

Step 5: Remove spotlight from the charger before operating.

See chart for recommended charge times.

Charge Times

Charge time is dependent on usage of the product. See chart below for recommended charge time.

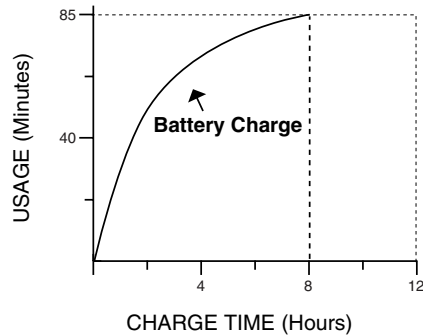

Only use Brinkmann xenon bulb that is designed for the Dual Xenon spotlight as a replacement. Use of any other bulb may result in poor performance and may damage your spotlight.

NOTE: Handling the bulb can leave oil from your fingers on the bulb. To extend the life of the new bulb and maximize brightness, gently clean off bulb with soft cloth or tissue. Make sure the reflector does not touch or bend the bulb while replacing spotlight head.

Step 1: Disconnect spotlight from charger.

Step 2: Remove front rubber cap from barrel of spotlight.

Step 3: Pinch the wings of the glass retainer together and lift as illustrated.

Step 4: Pull glass and reflector away from rear housing.

Step 5: Pull old bulb straight out of bulb holder.

Step 6: Make certain that "legs" on new bulb are straight. Insert "legs" into the two holes in the bulb holder.

Step 7: Gently push bulb straight in until fully seated and centered.

Step 8: To reassemble, place the glass and reflector on the rear housing. Insert the glass retainer into the rear housing.

Step 9: Replace rubber cap.

WARNING: Do not touch the lamps when light is on or if it was recently on. The lamps will be hot and could cause serious burns.

To Hang/Store Dual Xenon

Tips to Avoid Damage to Your Dual Xenon Spotlight

The retractable hanging ring allows spotlight to hang while in use or during storage.

- Never attempt to wipe or clean the inner reflective surface of the reflector. Touching or wiping the surface will damage it permanently.
- The lens is made of tempered glass. Avoid dropping or sharp impact on spotlight to prevent damage.
- Do not allow hot lens to come in contact with water or materials subject to heat damage.
- The spotlight is weather resistant. It is not waterproof. Do not use the spotlight under water or store outdoors.
- Use only Brinkmann xenon bulb that is designed for your Dual Xenon spotlight. Use of any other bulb may result in poor performance and may damage your spotlight.
- After months of use, cigarette lighters can build up corrosion that may prevent the DC lighter plug from making good contact. It may be necessary to clean the inside of your cigarette lighter receptacle with a fine emery cloth. Before cleaning receptacle, remove the fuse to prevent it from shorting out.

1-YEAR LIMITED WARRANTY

For 1-year from date of purchase, The Brinkmann Corporation warrants the Dual Xenon spotlight against defects due to workmanship or materials to the original purchaser. The Brinkmann Corporation's obligations under this warranty are limited to the following guidelines:

- This warranty does not extend to the bulb or batteries.
- This warranty does not cover spotlights that have been altered or damaged due to: normal wear, abuse, improper maintenance, improper use, disassembly of parts and/or attempted repair by anyone other than an authorized employee of The Brinkmann Corporation.
- This warranty does not cover surface scratches or weathering as this is considered normal wear.
- Warranty service is limited to repair or replacement of spotlights which prove defective under normal use and which upon examination shall indicate to Brinkmann's satisfaction, they are defective. If Brinkmann confirms the defect and approves the claim, Brinkmann will elect to repair or replace the spotlight as covered by the terms of this warranty.
- This warranty extends to the original purchaser only and is not transferable or assignable to subsequent purchasers.

The Brinkmann Corporation requires reasonable proof of purchase. Therefore, we strongly recommend that you retain your sales receipt or invoice. To obtain repair or replacement of your Dual Xenon spotlight under the terms of this warranty, please call Customer Service Department at 1-800-527-0717 for a Return Authorization Number and further instructions. A receipt will be required. A Return Authorization Number must be clearly marked on the outside of the box. Spotlights returned to Brinkmann must include your name, address and telephone number. Please make sure the light is properly packed, postage prepaid, and insured. The Brinkmann Corporation will not be responsible for any spotlights forwarded to us without a Return Authorization Number.

EXCEPT AS ABOVE STATED, THE BRINKMANN CORPORATION MAKES NO OTHER EXPRESS WARRANTY.

THE IMPLIED WARRANTIES OF MERCHANTABILITY AND FITNESS FOR A PARTICULAR PURPOSE ARE LIMITED IN DURATION TO 1-YEAR FROM THE DATE OF PURCHASE. SOME STATES DO NOT ALLOW LIMITATIONS ON HOW LONG AN IMPLIED WARRANTY LASTS, SO THE ABOVE LIMITATION MAY NOT APPLY TO YOU.

ANY LIABILITY FOR INDIRECT, INCIDENTAL OR CONSEQUENTIAL DAMAGES ARISING FROM THE FAILURE OF THE DUAL XENON SPOTLIGHT TO COMPLY WITH THIS WARRANTY OR ANY IMPLIED WARRANTY IS EXCLUDED. CUSTOMER ACKNOWLEDGES THAT THE PURCHASE PRICE CHARGED IS BASED UPON THE LIMITATIONS CONTAINED IN THE WARRANTY SET OUT ABOVE. SOME STATES DO NOT ALLOW THE EXCLUSION OR LIMITATION OF INCIDENTAL OR CONSEQUENTIAL DAMAGES, SO THE ABOVE LIMITATION OR EXCLUSION MAY NOT APPLY TO YOU. THIS WARRANTY GIVES YOU SPECIFIC LEGAL RIGHTS, AND YOU MAY ALSO HAVE OTHER RIGHTS WHICH VARY FROM STATE TO STATE.