

This manual is for reference and historical purposes, all rights reserved.

This page is copyright© by M. Butkus, NJ.

This page may not be sold or distributed without the expressed permission of the producer
I have no connection with any camera company

On-line camera manual library – www.orphancameras.com

This is the full text and images from the manual. This may take 3 full minutes for the PDF file to download depending on your connection type.

If you find this manual useful, how about a donation of \$3 to: M. Butkus, 29 Lake Ave., High Bridge, NJ 08829-1701 and send your e-mail address so I can thank you. Most other places would charge you \$7.50 for a electronic copy or \$18.00 for a hard to read Xerox copy.

This will allow me to continue to buy new manuals and pay their shipping costs.

It'll make you feel better, won't it?

**If you use Pay Pal or wish to use your credit card,
click on the secure site on my main page.**

argus C-44
interchangeable
lenses



Brentwood, Tenn. 37027

argus C44 interchangeable lenses provide the right focal length for every picture

Instantly interchangeable Argus Cintagon Lenses let you take full advantage of the versatility built into your C44 Camera.

The Argus C44 35mm Wide Angle and 100mm Telephoto lenses feature rigid, bayonet-type mounts like those on the world's most expensive cameras. You may interchange them quickly and easily. Hard-coated and color-corrected, they also boast easy-to-read depth of field scales, "click stop" aperture settings, and the Argus Color-matic system of "universal" settings for simplified picture taking. Built-in lens hoods keep the direct rays of the sun from striking the lens, and also serve as retaining rings for filters and supplementary lenses.

Because Argus products are constantly being improved, minor changes in appearance of the product may not be included in this instruction book.

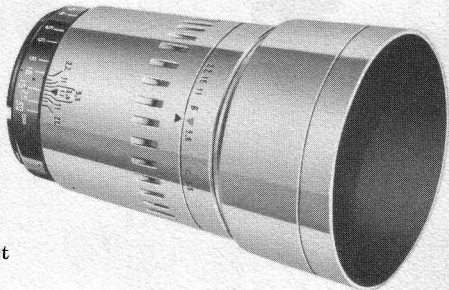
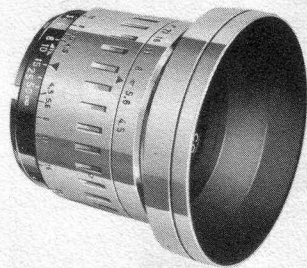



35mm Wide Angle Lens—Very useful for candid work because of its extremely great depth of field, this f:4.5 Cintagon lens covers 87% more area than the standard lens. It lets you include more scenery in your vacation slides and is just the thing where there is little room to step back from your subject.



50mm Standard Lens—This fast, four-element Cintagon lens is capable of handling a wide variety of picture-taking situations. Its large maximum aperture of f:2.8 allows you to take pictures even under very low light conditions . . . with modern “high speed” films, indoor photography by existing light is a snap!

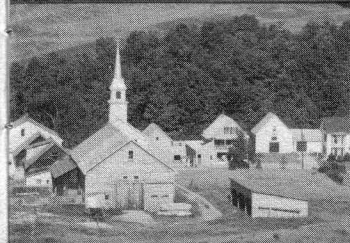

100mm Telephoto Lens—This f:3.5 Cintagon lens reaches out . . . bringing your subject twice as close. Its 100mm focal length makes candid shots easier and permits “close-ups” without standing close! Because it provides enlarged pictures of distant subjects, you’ll use it to shoot far-away wildlife and sports events.

installation and removal

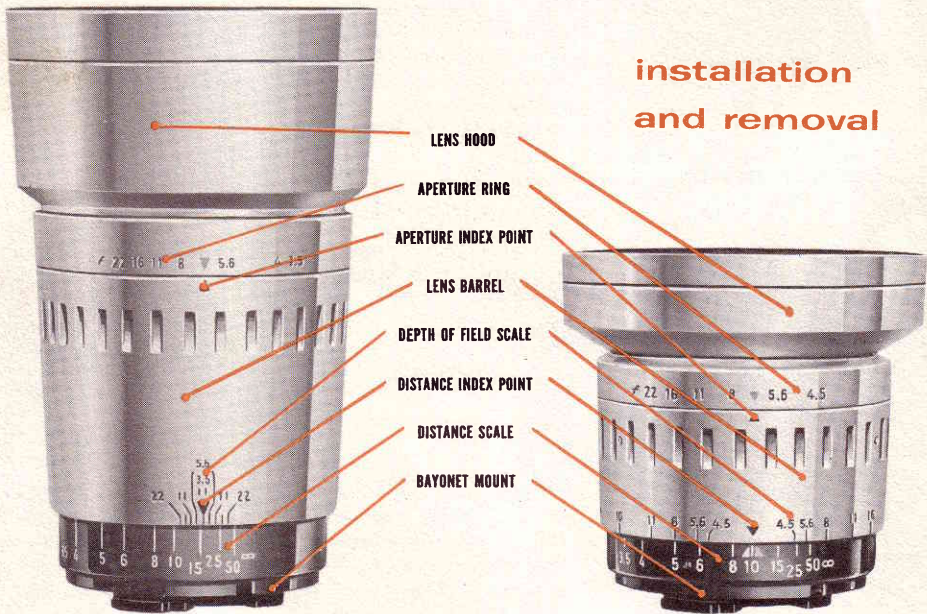

The ease with which lenses of the Argus C44 are interchanged will amaze you! A push of a button and a twist of the wrist removes the lens . . . a simple alignment of red dots, insertion of lens, and another twist of the wrist locks the lens securely in place, automatically coupled to the rangefinder.

You can change to the appropriate lens in seconds.

To protect the delicate mechanism of the shutter, NEVER LEAVE CAMERA WITHOUT A LENS ON IT. Also avoid changing lenses in bright sunlight. When lenses are not in use, they should be stored in their leather carrying cases.

REMOVAL

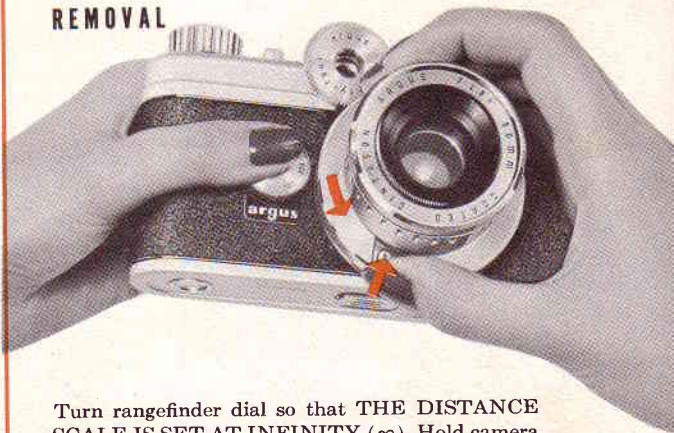

Turn rangefinder dial so that THE DISTANCE SCALE IS SET AT INFINITY (∞). Hold camera in left hand so that rangefinder dial and body lens mount are free to turn during uncoupling operation. Hold lens barrel with right hand. While right thumb is pushing up on lens lock release, give lens barrel a quarter-turn to the left (counter-clockwise) and lift lens out.

INSTALLATION

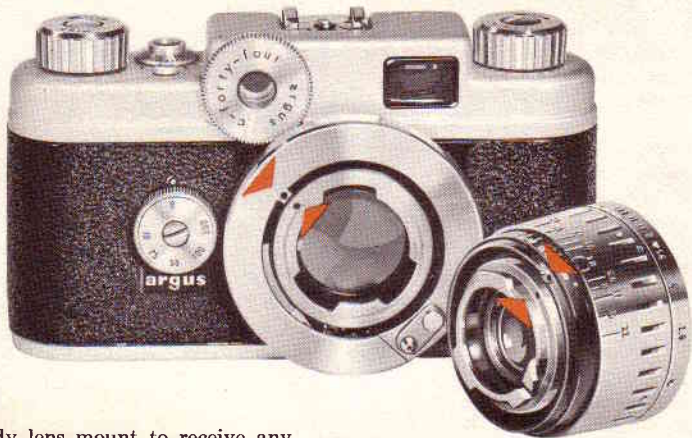

To prepare the body lens mount to receive any of the lenses, turn the rangefinder dial to bring the red dots in the mount opposite each other.

To prepare any of the three lenses for insertion, line up the red dots on the lens bayonet mount by turning the black distance scale to infinity (∞).

Insert lens carefully into the body lens mount, fitting the notch in the black outer ring over the square projection in the body lens mount. (See illustration.) When lens is fully seated, turn it to the right (clockwise) as far as it will go (about a quarter-turn), allowing rangefinder dial and body lens mount to turn freely.

That's all there is to it! The lens is locked securely in place, and is automatically coupled to the rangefinder. Aperture settings and depth of field scale will always be easy to read, centered on top of the lens barrel.



Both the Wide Angle and Telephoto accessory lenses feature ARGUS COLOR-MATIC aperture settings that may be used with average subjects in bright sunlight. The Wide Angle lens also has a Color-matic distance setting for universal sharp focus. (The Telephoto lens should be focused sharply for each picture.) Use yellow markings with Kodachrome Daylight film, red markings with Ektachrome or Anscochrome Daylight color films and with Plus-X, Supreme or similar black-and-white films (ASA 32-80).

Like your standard Cintagon lens, both accessory lenses have a DEPTH OF FIELD SCALE engraved on the lens barrel, showing at a glance the range of sharp focus in your pictures. This range of sharp focus in front of and beyond your principal subject increases as you get farther from your subject or use a smaller aperture. It is also greater in wide angle lenses than in normal or telephoto lenses, because depth of field increases as focal length decreases.

color-matic
settings ○
and
depth-of-field
scale ⌒

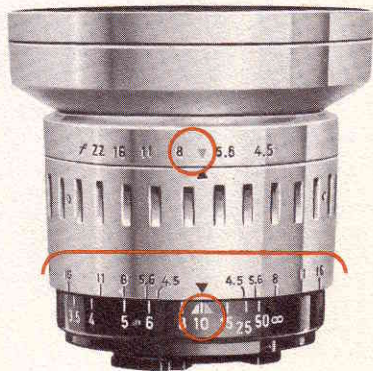

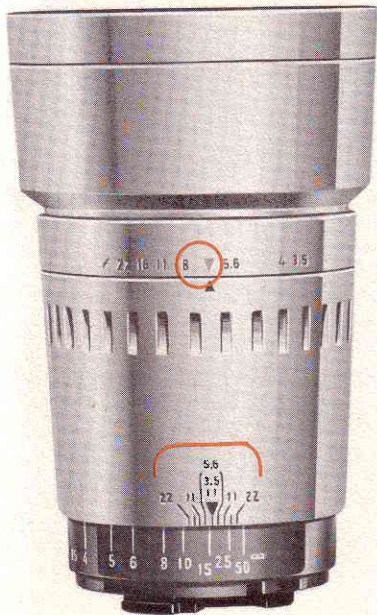

Leather cases designed especially for your valuable C44 accessory lenses will protect them from fingerprints and scratches. Should a lens require cleaning, blow off the dust (or use soft brush with light touch), breathe on lens surface, and wipe *gently* with soft lens tissue.

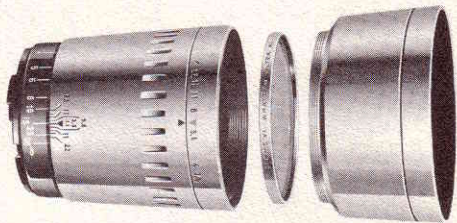

To insert filter, grasp aperture ring and unscrew lens hood; place filter in front of lens, and screw lens hood on again. Both accessory lenses accept Series VI (1 $\frac{5}{8}$ " diameter) filters and supplementary lenses. The built-in lens hoods help to keep direct rays of the sun from striking your lenses.

argus
variable power
viewfinder

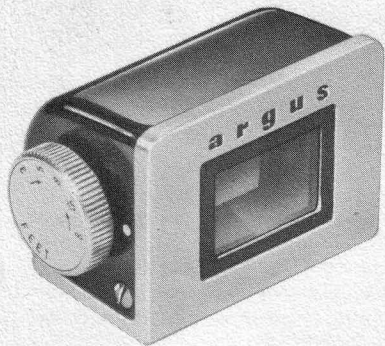

The completely new Argus Variable Power Viewfinder, featuring a unique precision optical system, gives you a choice of three magnifications in field of view, corresponding to the areas "seen" by your 35mm Wide Angle, 50mm Standard and 100mm Telephoto lenses. A built-in parallax adjustment compensates for differences that would otherwise occur between the fields of view of the lenses and the viewfinder . . . it tilts the lens system within the viewfinder so that you can see precisely what the lens sees at every distance. The Argus Variable Power Viewfinder may be mounted on any camera equipped with an Argus Accessory Shoe on top.

Simply set one dial for the focal length of the lens you are using. (A system of lenses rotates within the viewfinder, providing the right magnification.) Set another dial for the distance you are from your subject. (This is the "parallax" adjustment.) Then compose your picture through the Variable Power Viewfinder. The field of view is not masked down, but magnified to the full proportions of the viewfinder.

flash extension bracket

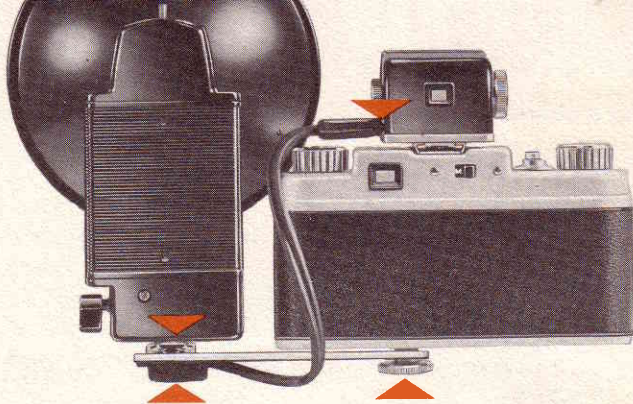

To take flash pictures when the Variable Power Viewfinder is used, mount your C44 flash unit on the new C44 Flash Extension Bracket. This metal bracket is held in place by the C44 case safety screw or by a tripod screw. To attach bracket, loosen screw on bottom of leather case and slide camera part-way out. Slip bracket into slot in end of case, and place hole in bracket over end of safety

screw. Slide camera back down onto screw, and tighten. Mount flash unit on bracket in the same way that you mount it on the camera, and plug cord into socket in Variable Power Viewfinder. To use the Flash Extension Bracket on your C44 without using the leather case, the case safety screw may be removed from the case to hold bracket on camera, as illustrated.

SPECIFICATIONS

WIDE ANGLE CINTAGON

Lens: 35mm, color-corrected, hard-coated anastigmat; helical-focusing, 3 ft. to infinity

f:stops: Click stop settings at f:4.5, 5.6, 6.3, 8, 11, 16, 22.

Hyperfocal Distance: 17 feet 7 inches at f:4.5

Full Field Angle: 64°30'

Filter Size: Series VI (1 $\frac{1}{8}$ ")

Carrying Case: Available as accessory in genuine leather.

TELEPHOTO CINTAGON

Lens: 100mm, color-corrected, hard-coated anastigmat; helical-focusing, 3 ft. to infinity.

f:stops: Click stop settings at f:3.5, 4, 5.6, 6.3, 8, 11, 16, 22.

Hyperfocal Distance: 184 feet 6 inches at f:3.5

Full Field Angle: 25°

Filter Size: Series VI (1 $\frac{1}{8}$ ")

Carrying Case: Available as accessory in genuine leather.

Lifetime guarantee

Your Argus Accessory Lens was manufactured, inspected and tested by skilled craftsmen. It is guaranteed to be free of defects in workmanship or material during its lifetime. If any servicing is necessary because of imperfections in materials or workmanship, your lens will be factory serviced without charge.

Argus equipment which has been damaged, mishandled or worn from extensive use will be factory serviced at established rates. Used or rebuilt equipment is not covered by this guarantee.

ARGUS CAMERAS, ANN ARBOR, MICHIGAN

Division of Sylvania Electric Products Inc.

ARGUS CAMERAS OF CANADA, LTD., TORONTO, ONTARIO