

WT
SECTION
ROAD WHEELS & TIRES

A
B
C
D

WT

CONTENTS

<p>PRECAUTIONS 2</p> <p style="padding-left: 20px;">Precautions for Supplemental Restraint System (SRS) "AIR BAG" and "SEAT BELT PRE-TENSIONER" 2</p> <p style="padding-left: 20px;">Precautions for work 2</p> <p>PREPARATION 3</p> <p style="padding-left: 20px;">Special Service Tool 3</p> <p style="padding-left: 20px;">Commercial Service Tools 3</p> <p>NOISE, VIBRATION, AND HARSHNESS (NVH)</p> <p>TROUBLESHOOTING 4</p> <p style="padding-left: 20px;">NVH Troubleshooting Chart 4</p> <p>WHEEL 5</p> <p style="padding-left: 20px;">Inspection 5</p> <p>WHEEL AND TIRE ASSEMBLY 6</p> <p style="padding-left: 20px;">Balancing Wheels 6</p> <p style="padding-left: 40px;">WHEEL BALANCE REMOVAL 6</p> <p style="padding-left: 40px;">WHEEL BALANCE INSTALLATION AND ADJUSTMENT 6</p> <p style="padding-left: 20px;">Rotation 7</p> <p>LOW TIRE PRESSURE WARNING SYSTEM 8</p> <p style="padding-left: 20px;">System Components 8</p> <p style="padding-left: 20px;">System Description 8</p> <p style="padding-left: 40px;">BODY CONTROL MODULE (BCM) 8</p> <p style="padding-left: 40px;">TRANSMITTER 9</p> <p style="padding-left: 40px;">REMOTE KEYLESS ENTRY RECEIVER 9</p> <p style="padding-left: 40px;">COMBINATION METER 9</p> <p>CAN COMMUNICATION 10</p> <p style="padding-left: 20px;">System Description 10</p> <p>TROUBLE DIAGNOSES 11</p> <p style="padding-left: 20px;">Wiring Diagram — T/WARN — 11</p> <p style="padding-left: 20px;">Terminals and Reference Values (BCM) 12</p> <p style="padding-left: 20px;">ID Registration Procedure 12</p> <p style="padding-left: 40px;">ID REGISTRATION WITH TRANSMITTER ACTIVATION TOOL 12</p> <p style="padding-left: 40px;">ID REGISTRATION WITHOUT TRANSMITTER ACTIVATION TOOL 13</p> <p style="padding-left: 20px;">Transmitter Wake Up Operation 14</p> <p style="padding-left: 20px;">CONSULT-II Function (BCM) 15</p>	<p style="padding-left: 20px;">Self-Diagnosis 15</p> <p style="padding-left: 40px;">DESCRIPTION 15</p> <p style="padding-left: 40px;">FUNCTION 15</p> <p style="padding-left: 20px;">How to Perform Trouble Diagnosis for Quick and Accurate Repair 17</p> <p style="padding-left: 40px;">INTRODUCTION 17</p> <p style="padding-left: 40px;">WORK FLOW 17</p> <p style="padding-left: 20px;">Preliminary Check 18</p> <p style="padding-left: 20px;">Flash Code/Symptom Chart 19</p> <p>TROUBLE DIAGNOSIS FOR SELF-DIAGNOSTIC ITEMS 20</p> <p style="padding-left: 20px;">Data From Transmitter Not Being Received 20</p> <p style="padding-left: 40px;">MALFUNCTION CODE NO. 21, 22, 23 OR 24 (DTC C1708, C1709, C1710 OR C1711) 20</p> <p style="padding-left: 20px;">Transmitter Malfunction 20</p> <p style="padding-left: 40px;">MALFUNCTION CODE NO. 31, 32, 33, 34, 41, 42, 43, 44, 45, 46, 47 OR 48 20</p> <p style="padding-left: 20px;">Transmitter Pressure Malfunction 21</p> <p style="padding-left: 40px;">MALFUNCTION CODE NO. 35, 36, 37 OR 38 ... 21</p> <p style="padding-left: 20px;">Vehicle Speed Signal 22</p> <p style="padding-left: 40px;">MALFUNCTION CODE NO. 52 (DTC C1729) ... 22</p> <p>TROUBLE DIAGNOSIS FOR SYMPTOMS 23</p> <p style="padding-left: 20px;">Low Tire Pressure Warning Lamp Does Not Come On When Ignition Switch Is Turned On 23</p> <p style="padding-left: 20px;">Low Tire Pressure Warning Lamp Stays On When Ignition Switch Is Turned On 23</p> <p style="padding-left: 20px;">Low Tire Pressure Warning Lamp Flashes When Ignition Switch Is Turned On 25</p> <p style="padding-left: 20px;">Hazard Warning Lamps Flash When Ignition Switch Is Turned On 26</p> <p style="padding-left: 20px;">ID Registration Cannot Be Completed 26</p> <p>REMOVAL AND INSTALLATION 27</p> <p style="padding-left: 20px;">Transmitter (Pressure Sensor) 27</p> <p style="padding-left: 40px;">REMOVAL 27</p> <p style="padding-left: 40px;">INSTALLATION 27</p> <p>SERVICE DATA AND SPECIFICATIONS (SDS) 29</p> <p style="padding-left: 20px;">Road Wheel 29</p> <p style="padding-left: 20px;">Tire 29</p>	<p>F</p> <p>G</p> <p>H</p> <p>I</p> <p>J</p> <p>K</p> <p>L</p> <p>M</p>
--	---	---

PRECAUTIONS

PRECAUTIONS

PF0:00001

Precautions for Supplemental Restraint System (SRS) “AIR BAG” and “SEAT BELT PRE-TENSIONER”

EES002C1

The Supplemental Restraint System such as “AIR BAG” and “SEAT BELT PRE-TENSIONER”, used along with a front seat belt, helps to reduce the risk or severity of injury to the driver and front passenger for certain types of collision. This system includes seat belt switch inputs and dual stage front air bag modules. The SRS system uses the seat belt switches to determine the front air bag deployment, and may only deploy one front air bag, depending on the severity of a collision and whether the front occupants are belted or unbelted. Information necessary to service the system safely is included in the SRS and SB section of this Service Manual.

WARNING:

- To avoid rendering the SRS inoperative, which could increase the risk of personal injury or death in the event of a collision which would result in air bag inflation, all maintenance must be performed by an authorized NISSAN/INFINITI dealer.
- Improper maintenance, including incorrect removal and installation of the SRS, can lead to personal injury caused by unintentional activation of the system. For removal of Spiral Cable and Air Bag Module, see the SRS section.
- Do not use electrical test equipment on any circuit related to the SRS unless instructed to in this Service Manual. SRS wiring harnesses can be identified by yellow and/or orange harnesses or harness connectors.

Precautions for work

EES002C2

- After removing and installing the opening/closing parts, be sure to carry out fitting adjustments to check their operation.
- Check the lubrication level, damage, and wear of each part. If necessary, grease or replace it.

PREPARATION

PREPARATION

PFP:00002

Special Service Tool

EES002U0

The actual shapes of Kent-Moore tools may differ from those of special service tools illustrated here.

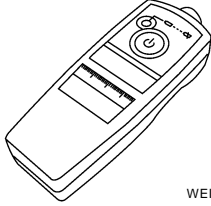
Tool number (Kent-Moore No.) Tool name	Description
KV991B1000 (J-45295) Transmitter activation tool	 WEIA0144E <ul style="list-style-type: none"> ● Transmitter wake up operation ● ID registration procedure

Commercial Service Tools

EES001RC

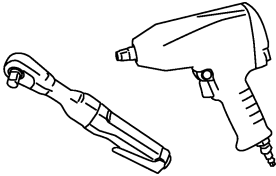
Tool name	Description
Power tool	 PBIC0190E <p>Removing wheel nuts</p>

A
B
C
D
WT
F
G
H
I
J
K
L
M

WHEEL

WHEEL

PFP:40300

EES001RE

Inspection

1. Remove wheel and tire using power tool.
2. Check tires for wear and improper inflation.
3. Check wheels for deformation, cracks and other damage. If deformed, remove wheel and check wheel runout.
 - a. Remove tire from wheel and mount wheel on a tire balance machine.
 - b. Set dial indicator as shown in the illustration. Refer to [WT-29, "Road Wheel"](#).
4. Check front wheel bearings for looseness.
5. Check front suspension for looseness.
6. Install wheel and tire. Refer to [WT-7, "Rotation"](#).

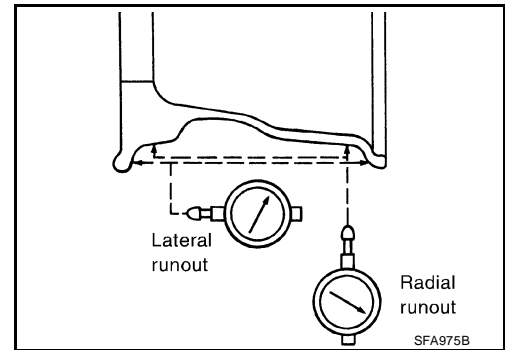

A

B

C

D

WT

F

G

H

I

J

K

L

M

WHEEL AND TIRE ASSEMBLY

WHEEL AND TIRE ASSEMBLY

PF0:40300

Balancing Wheels

WHEEL BALANCE REMOVAL

EES001RF

1. Remove wheel and tire using power tool.
2. Using releasing agent, remove double-faced adhesive tape from the wheel.

CAUTION:

- Be careful not to scratch the wheel during removal.
- After removing double-faced adhesive tape, wipe clean traces of releasing agent from the wheel.

WHEEL BALANCE INSTALLATION AND ADJUSTMENT

- If a tire balance machine has adhesion balance weight mode settings and drive-in weight mode setting, select and adjust a drive-in weight mode suitable for wheels.
1. Set wheel on wheel balancer using the center hole as a guide. Start the tire balance machine.
 2. When inner and outer imbalance values are shown on the wheel balancer indicator, multiply outer imbalance value by 1.6 to determine balance weight that should be used. Select the outer balance weight with a value closest to the calculated value and install it to the designated outer position of, or at the designated angle in relation to the road wheel.

CAUTION:

- Do not install the inner balance weight before installing the outer balance weight.
- Before installing the balance weight, be sure to clean the mating surface of the wheel.

Indicated imbalance value $\times 5/3$ = balance weight to be installed

Calculation example:

23 g (0.81 oz) $\times 5/3$ = 38.33 g (1.35 oz) = 40 g (1.41 oz) balance weight (closer to calculated balance weight value)

Note that balance weight value must be closer to the calculated balance weight value.

Example:

37.4 g = 35 g (1.23 oz)

37.5 g = 40 g (1.41 oz)

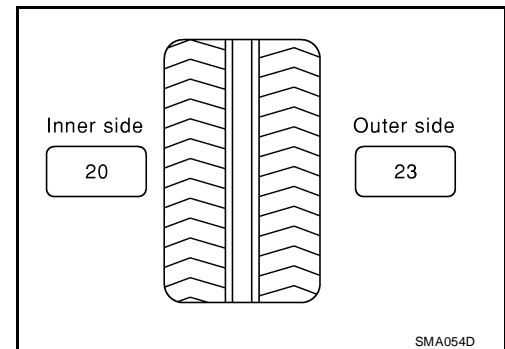

- a. Install balance weight in the position shown.
- b. When installing balance weight to wheels, set it into the grooved area on the inner wall of the wheel as shown so that the balance weight center is aligned with the wheel balancer indication position (angle).

CAUTION:

- Always use Genuine NISSAN adhesion balance weights.
- Balance weights are not reusable; always replace with new ones.
- Do not install more than three sheets of balance weights.

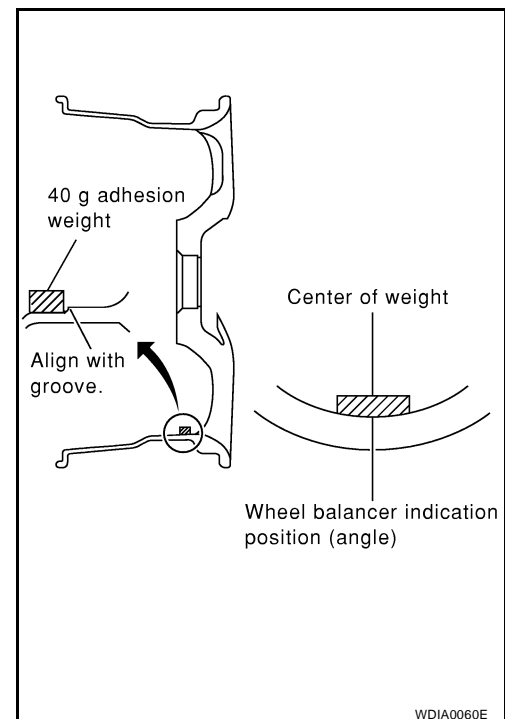

WHEEL AND TIRE ASSEMBLY

- c. If calculated balance weight value exceeds 50 g (1.76 oz), install two balance weight sheets in line with each other as shown.

CAUTION:

Do not install one balance weight sheet on top of another.

- Start wheel balancer again.
- Install drive-in balance weight on inner side of road wheel in the wheel balancer indication position (angle).

CAUTION:

Do not install more than two balance weights.

- Start wheel balancer. Make sure that inner and outer residual imbalance values are 5g (0.18 oz) each or below.

- If either residual imbalance value exceeds 5 g (0.18 oz), repeat installation procedures.

Wheel balance (Maximum allowable imbalance):

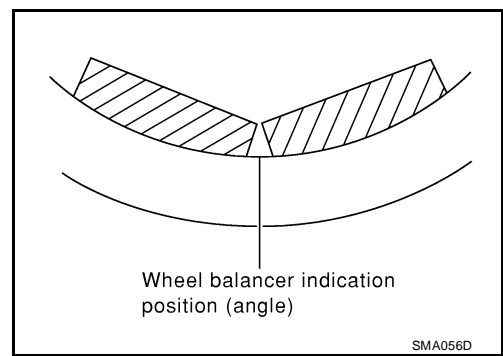

Maximum allowable imbalance	Dynamic (At rim flange)	5 g (0.18 oz) (one side)
	Static	10 g (0.35 oz)

Rotation

EES001RG

NOTE:

Follow the maintenance schedule for tire rotation service intervals. Refer to [MA-5, "GENERAL MAINTENANCE"](#).

- Remove wheels and tires.
- Rotate wheels and tires on each side from front to back as shown. Do not include the spare wheel and tire when rotating the wheels and tires.

Wheel nut : 133 N·m (14 kg·m, 98 ft·lb)

CAUTION:

When installing wheels and tires, tighten them diagonally by dividing the work two to three times in order to prevent the wheels from developing any distortion.

- Adjust the tire pressure to specification. Refer to [WT-29, "Tire"](#).
- After the wheel and tire rotation, retighten the wheel nuts after the vehicle has been driven for 1,000 km (600 miles), and also after any wheel and tire has been installed, such as after repairing a flat tire.

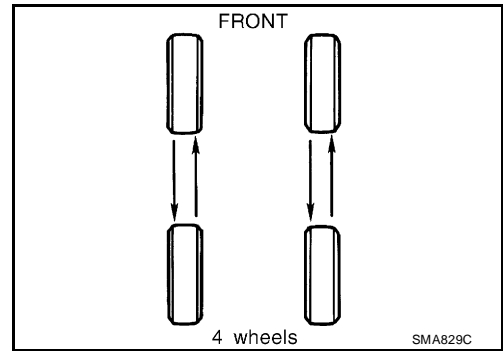

LOW TIRE PRESSURE WARNING SYSTEM

LOW TIRE PRESSURE WARNING SYSTEM

PF:40300

System Components

EES001UZ

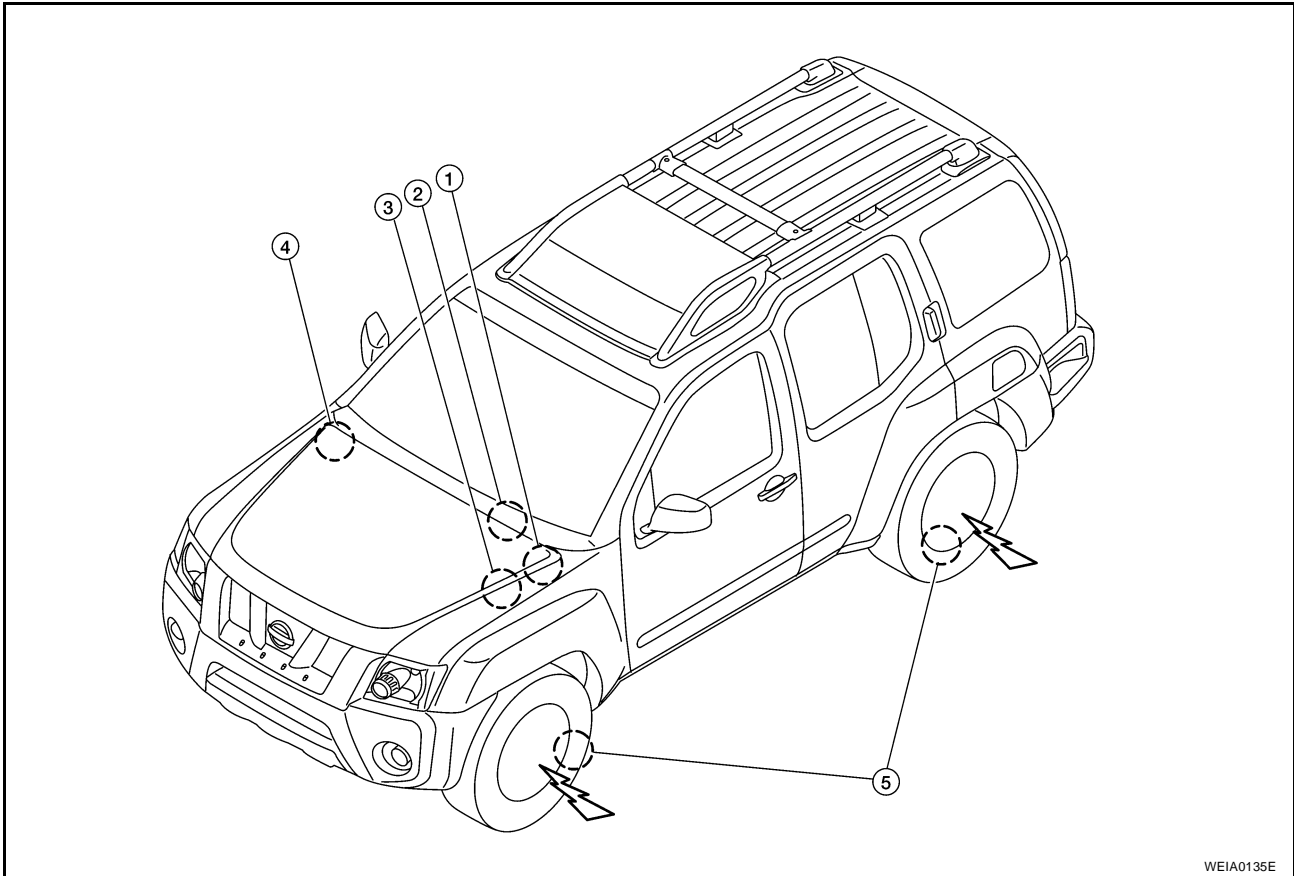

WEIA0135E

- | | | |
|----------------------------------|----------------------|--|
| 1. BCM | 2. Combination meter | 3. Tire pressure warning check connector |
| 4. Remote keyless entry receiver | 5. Transmitters | |

System Description BODY CONTROL MODULE (BCM)

EES002UP

The BCM is shown with the lower instrument panel LH removed. The BCM reads the air pressure signal received by the remote keyless entry receiver, and controls the low tire pressure warning lamp as shown below. It also has a self-diagnosis function to detect a system malfunction.

Condition	Low tire pressure warning lamp
System normal	On for 1 second after ignition ON
Tire less than 193 kPa (2.0 kg/cm ² , 28 psi) [Flat tire]	ON
Low tire pressure warning system malfunction	After key ON, flashes once per second for 1 minute, then stays ON

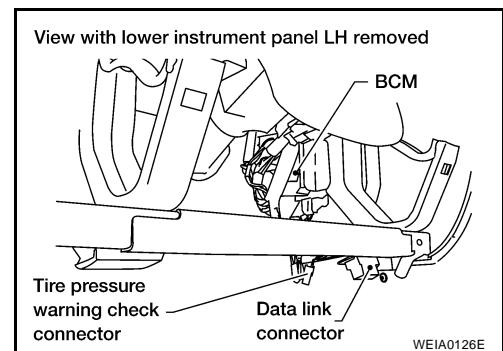

WEIA0126E

LOW TIRE PRESSURE WARNING SYSTEM

TRANSMITTER

A sensor-transmitter integrated with a valve is installed in each wheel, and transmits a detected air pressure signal in the form of a radio wave. The radio signal is received by the remote keyless entry receiver.

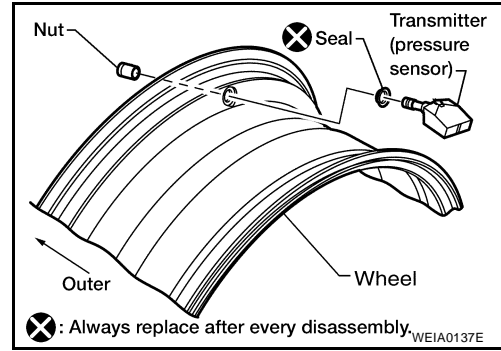

REMOTE KEYLESS ENTRY RECEIVER

The remote keyless entry receiver is shown with the instrument panel RH removed. The remote keyless entry receiver receives the air pressure signal transmitted by the transmitter in each wheel.

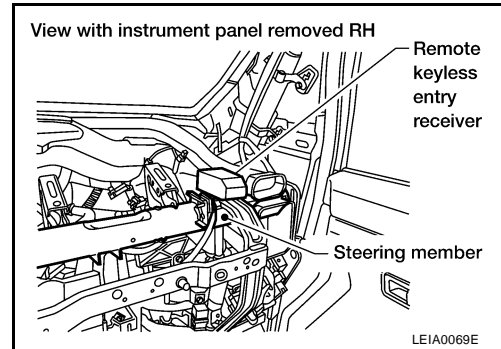

COMBINATION METER

The combination meter receives tire pressure status from the BCM using CAN communication. When a low tire pressure condition is sensed by the BCM, the combination meter low tire pressure warning lamp is activated.

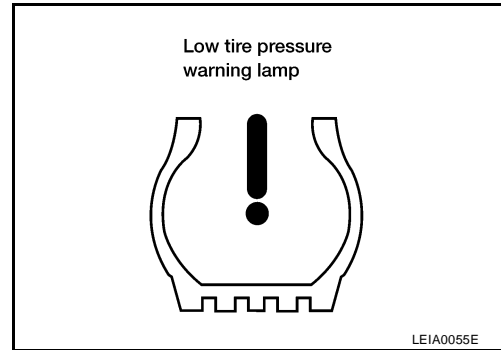

A
B
C
D
WT
F
G
H
I
J
K
L
M

CAN COMMUNICATION

CAN COMMUNICATION

PF2:23710

System Description

EES002UQ

Refer to [LAN-4, "SYSTEM DESCRIPTION"](#) .

TROUBLE DIAGNOSES

PF0:0004

TROUBLE DIAGNOSES

Wiring Diagram — T/WARN —

EES001V1

WT-T/WARN-01

— — — — — : DATA LINE

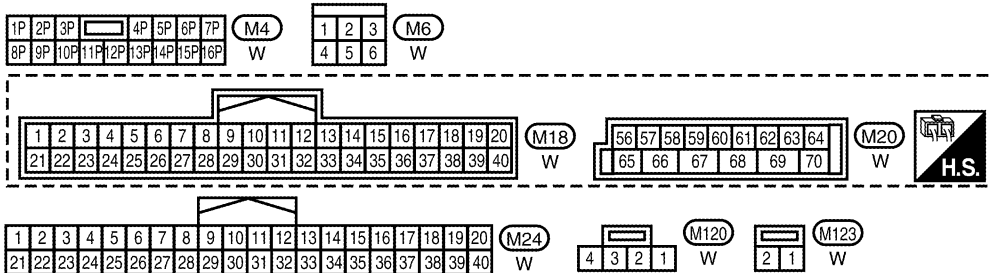
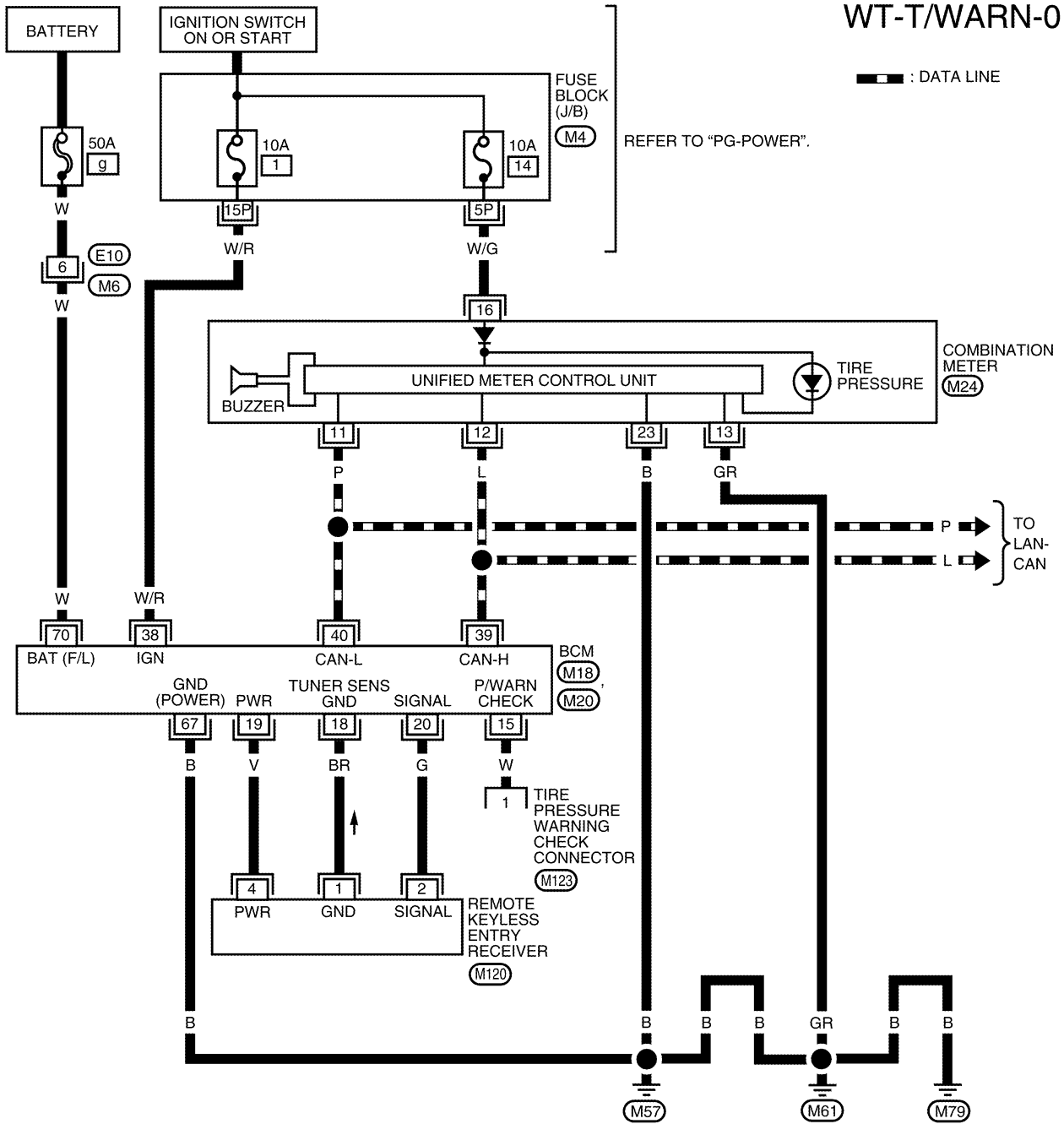

WEWA0071E

TROUBLE DIAGNOSES

EES001V2

Terminals and Reference Values (BCM)

Refer to [BCS-12, "Terminals and Reference Values for BCM"](#).

ID Registration Procedure

EES002UR

ID REGISTRATION WITH TRANSMITTER ACTIVATION TOOL

NOTE:

This procedure must be done after replacement of a low tire pressure warning transmitter or BCM. New replacement transmitters are provided "asleep" and must first be "woken up" using Transmitter Activation Tool J-45295 before ID registration can be performed.

1. Connect CONSULT-II. Refer to [GI-38, "CONSULT-II Start Procedure"](#).
2. Select "AIR PRESSURE MONITOR" on "SELECT TEST ITEM" screen.
3. Select "WORK SUPPORT" on "SELECT DIAG MODE" screen, and select "ID REGIST".

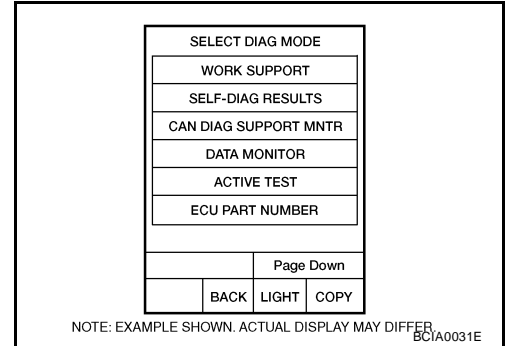

4. Push the transmitter activation tool against the tire near the front left transmitter. Press the button for 5 seconds.

Tool number : (J-45295)

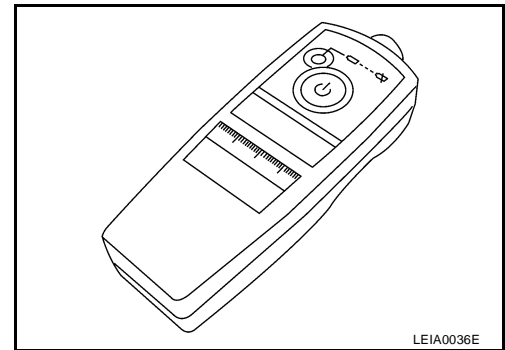

5. Register the IDs in order from FR LH, FR RH, RR RH and RR LH. When ID registration of each wheel has been completed, a buzzer sounds and the hazard warning lamps flash.

Activation tire position	Buzzer	Hazard warning lamp	CONSULT-II
1 Front LH	Once	2 times flashing	"YET" ↓ "DONE"
2 Front RH	2 times		
3 Rear RH	3 times		
4 Rear LH	4 times		

6. After completing all ID registrations, press "END" to complete the procedure.

NOTE:

Be sure to register the IDs in order from FR LH, FR RH, RR RH, to RR LH, or the self-diagnostic results display will not function properly.

TROUBLE DIAGNOSES

ID REGISTRATION WITHOUT TRANSMITTER ACTIVATION TOOL

NOTE:

This procedure must be done after replacement of a low tire pressure warning transmitter or BCM. New replacement transmitters are provided "asleep" and must first be "woken up" using Transmitter Activation Tool J-45295 before ID registration can be performed.

1. Connect CONSULT-II. Refer to [GI-38, "CONSULT-II Start Procedure"](#) .
2. Select "AIR PRESSURE MONITOR" on "SELECT TEST ITEM" screen.
3. Select "WORK SUPPORT" on "SELECT DIAG MODE" screen, and select "ID REGIST".
4. Adjust the tire pressure to the values shown in the table below and drive the vehicle at 15 km/h (9.4 MPH) or more for a few minutes.

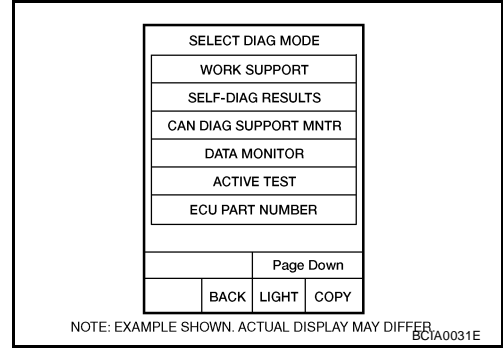

Tire position	Tire pressure kPa (kg/cm ² , psi)
Front – Left	250 (2.5, 36)
Front – Right	230 (2.3, 33)
Rear – Right	210 (2.1, 30)
Rear – Left	190 (1.9, 27)

5. After completing all ID registrations, press "END" to complete the procedure.

Activation tire position	CONSULT-II
Front LH	"YET" ↓ "DONE"
Front RH	
Rear RH	
Rear LH	

6. Inflate all tires to proper pressure. Refer to [WT-29, "Tire"](#) .

TROUBLE DIAGNOSES

EES002US

Transmitter Wake Up Operation

NOTE:

This procedure must be done after replacement of a low tire pressure warning transmitter or BCM. New replacement transmitters are provided "asleep" and must first be "woken up" using Transmitter Activation Tool J-45295 before ID registration can be performed.

1. Turn ignition switch ON. Push the transmitter activation tool against the tire near the front left transmitter. Press the button for 5 seconds. The hazard warning lamps flash per the diagram below.

Tool number : (J-45295)

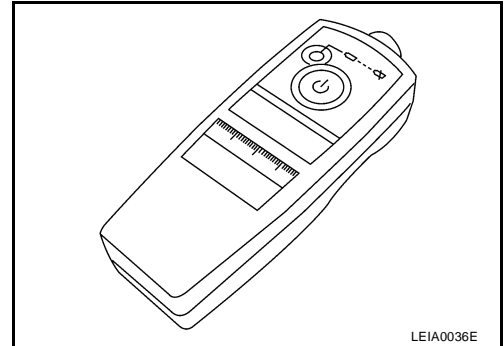

2. Repeat this procedure for each tire in the following order: FL, FR, RR, RL.
3. When the BCM finishes assigning each tire ID, the BCM flashes the hazard warning lamps and sends flashing indicator status by CAN according to the following time chart.

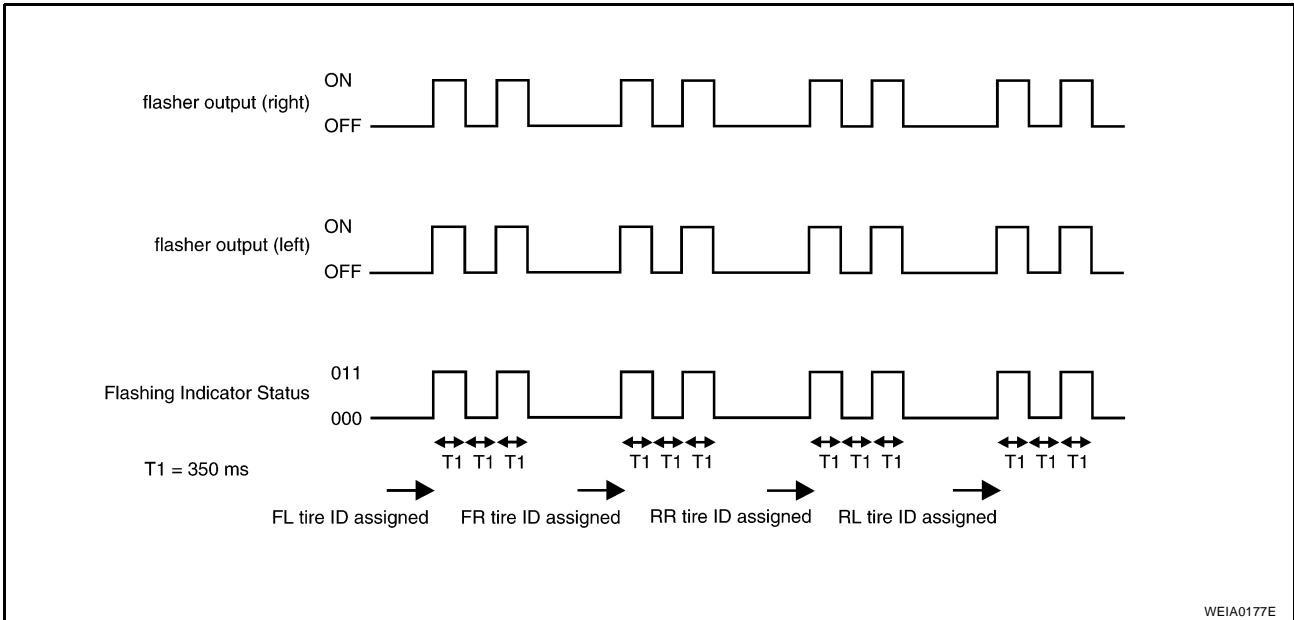

4. After completing wake up of all transmitters, make sure low tire pressure warning lamp goes out.

TROUBLE DIAGNOSES

CONSULT-II Function (BCM)

EES001V5

CONSULT-II can display each diagnostic item using the diagnostic test modes shown following.

BCM diagnostic test item	Diagnostic mode	Description
Inspection by part	WORK SUPPORT	Supports inspections and adjustments. Commands are transmitted to the BCM for setting the status suitable for required operation, input/output signals are received from the BCM and received data is displayed.
	DATA MONITOR	Displays BCM input/output data in real time.
	ACTIVE TEST	Operation of electrical loads can be checked by sending drive signal to them.
	SELF-DIAG RESULTS	Displays BCM self-diagnosis results.
	CAN DIAG SUPPORT MNTR	The result of transmit/receive diagnosis of CAN communication can be read.
	ECU PART NUMBER	BCM part number can be read.
	CONFIGURATION	Performs BCM configuration read/write functions.

Self-Diagnosis DESCRIPTION

EES002UT

During driving, the low tire pressure warning system receives the signal transmitted from the transmitter installed in each wheel, and turns on the low tire pressure warning lamp when the tire pressure becomes low. The control unit (BCM) for this system has pressure judgement and self-diagnosis functions.

FUNCTION

When the low tire pressure warning system detects low inflation pressure or an internal malfunction, the low tire pressure warning lamp in the combination meter comes on. The malfunction location is indicated by the low tire pressure warning lamp flashing and the buzzer sounding.

CONSULT-II Application to Low Tire Pressure Warning System

ITEM	SELF-DIAGNOSTIC RESULTS	DATA MONITOR
Front - Left transmitter	×	×
Front - Right transmitter	×	×
Rear - Left transmitter	×	×
Rear - Right transmitter	×	×
Warning lamp	—	×
Vehicle speed	×	×
Buzzer (in combination meter)	—	×
CAN Communication	×	×

× : Applicable

— : Not applicable

TROUBLE DIAGNOSES

Self-Diagnostic Results Mode

Diagnostic item		Diagnostic item is detected when ...	Reference page
Program card UED06A or earlier	Program card UED06B or later		
FLAT - TIRE - FL [C1704] FLAT - TIRE - FR [C1705] FLAT - TIRE - RR [C1706] FLAT - TIRE - RL [C1707]	LOW - PRESSURE - FL [C1704] LOW - PRESSURE - FR [C1705] LOW - PRESSURE - RR [C1706] LOW - PRESSURE - RL [C1707]	FL tire pressure 193 kPa (2.0 kg/cm ² , 28 psi) or less FR tire pressure 193 kPa (2.0 kg/cm ² , 28 psi) or less RR tire pressure 193 kPa (2.0 kg/cm ² , 28 psi) or less RL tire pressure 193 kPa (2.0 kg/cm ² , 28 psi) or less	—
[NO-DATA] - FL [C1708] [NO-DATA] - FR [C1709] [NO-DATA] - RR [C1710] [NO-DATA] - RL [C1711]		Data from FL transmitter cannot be received. Data from FR transmitter cannot be received. Data from RR transmitter cannot be received. Data from RL transmitter cannot be received.	WT-20
[CHECKSUM- ERR] - FL [CHECKSUM- ERR] - FR [CHECKSUM- ERR] - RR [CHECKSUM- ERR] - RL		Checksum data from FL transmitter is malfunctioning. Checksum data from FR transmitter is malfunctioning. Checksum data from RR transmitter is malfunctioning. Checksum data from RL transmitter is malfunctioning.	WT-20
[PRESSDATA- ERR] - FL [PRESSDATA- ERR] - FR [PRESSDATA- ERR] - RR [PRESSDATA- ERR] - RL		Air pressure data from FL transmitter is malfunctioning. Air pressure data from FR transmitter is malfunctioning. Air pressure data from RR transmitter is malfunctioning. Air pressure data from RL transmitter is malfunctioning.	WT-21
[CODE- ERR] - FL [CODE- ERR] - FR [CODE- ERR] - RR [CODE- ERR] - RL		Function code data from FL transmitter is malfunctioning. Function code data from FR transmitter is malfunctioning. Function code data from RR transmitter is malfunctioning. Function code data from RL transmitter is malfunctioning.	WT-20
[BATT - VOLT - LOW] - FL [BATT - VOLT - LOW] - FR [BATT - VOLT - LOW] - RR [BATT - VOLT - LOW] - RL		Battery voltage of FL transmitter drops. Battery voltage of FR transmitter drops. Battery voltage of RR transmitter drops. Battery voltage of RL transmitter drops.	WT-20
VHCL_SPEED_SIG_ERR [C1729]		Vehicle speed signal is in error.	WT-22

NOTE:

Before performing the self-diagnosis, be sure to register the ID or else the actual malfunction location may be different from that displayed on CONSULT-II.

Data Monitor Mode

MONITOR	CONDITION	SPECIFICATION
VHCL SPEED	Drive vehicle.	Vehicle speed (km/h or MPH)
AIR PRESS FL AIR PRESS FR AIR PRESS RR AIR PRESS RL	<ul style="list-style-type: none"> ● Drive vehicle for a few minutes. <li style="text-align: center;">or ● Ignition switch ON and activation tool is transmitting activation signals. 	Tire pressure (kPa or psi)
ID REGST FL1 ID REGST FR1 ID REGST RR1 ID REGST RL1	Ignition switch ON	Registration ID: DONE No registration ID: YET
WARNING LAMP		Low tire pressure warning lamp on: ON Low tire pressure warning lamp off: OFF
BUZZER		Buzzer in combination meter on: ON Buzzer in combination meter off: OFF

NOTE:

Before performing the self-diagnosis, be sure to register the ID, or the actual malfunction location may be different from that displayed on CONSULT-II.

TROUBLE DIAGNOSES

How to Perform Trouble Diagnosis for Quick and Accurate Repair

EE5001V7

INTRODUCTION

- Before troubleshooting, verify customer complaints.
- If a vehicle malfunction is difficult to reproduce, harnesses, harness connectors or terminals may be malfunctioning. Hold and shake these parts to make sure they are securely connected.
- When using a circuit tester to measure voltage or resistance of each circuit, be careful not to damage or deform connector terminals.

WORK FLOW

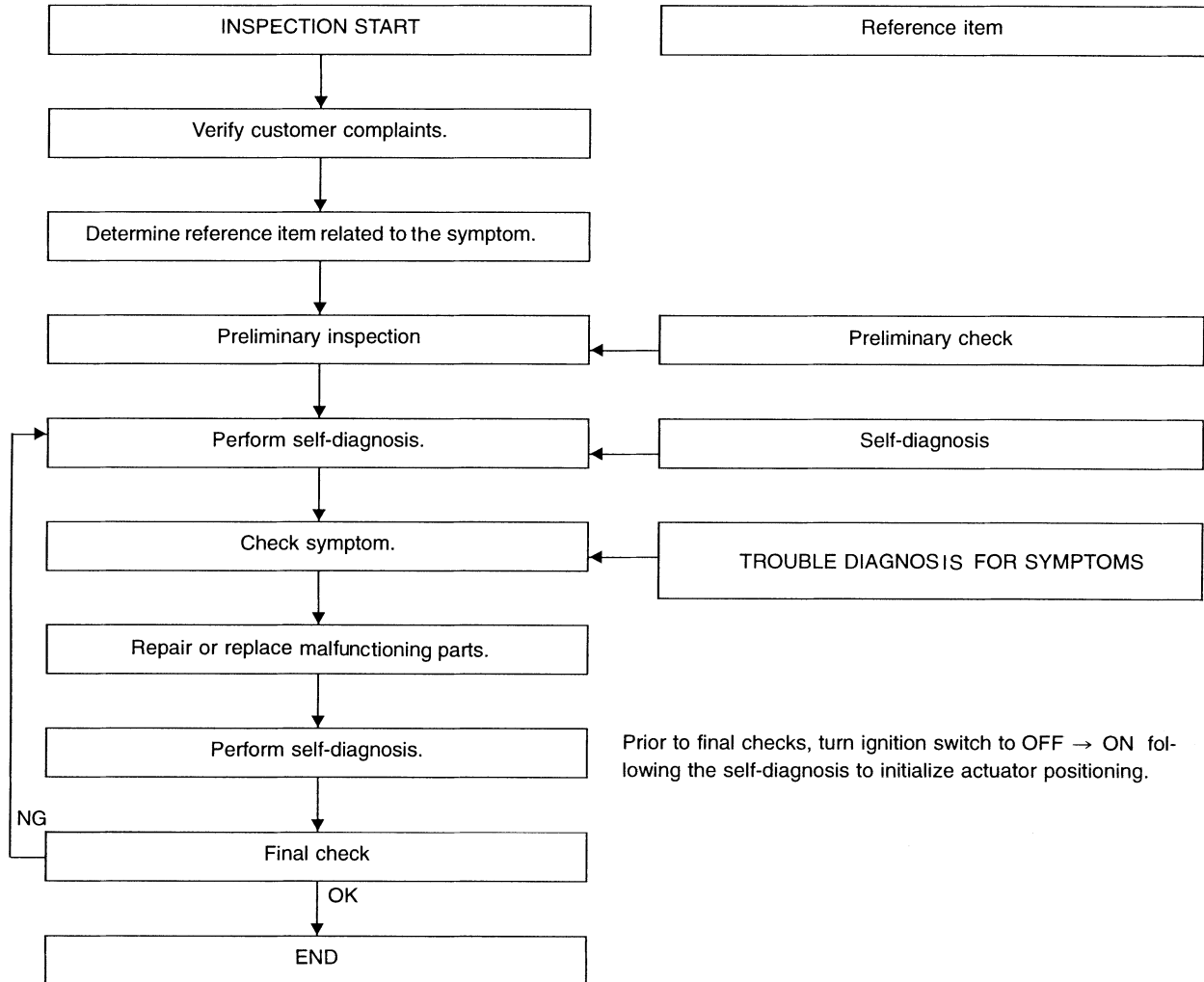

Preliminary check: [WT-18](#)

Self-diagnosis: [WT-15](#)

Trouble diagnosis for symptoms: [WT-23](#)

SEIA0100E

TROUBLE DIAGNOSES

EES002UU

Preliminary Check

BASIC INSPECTION

1. CHECK ALL TIRE PRESSURES

Check all tire pressures. Refer to [WT-29](#) .

OK or NG

- OK >> GO TO 2.
- NG >> Adjust tire pressure to specified value.

2. CHECK LOW TIRE PRESSURE WARNING LAMP ACTIVATION

Check low tire pressure warning lamp activation.

Does warning lamp activate for 1 second when ignition switch is turned ON?

- YES >> GO TO 3.
- NO >> GO TO [WT-23, "Low Tire Pressure Warning Lamp Does Not Come On When Ignition Switch Is Turned On"](#) .

3. CHECK BCM CONNECTOR

1. Disconnect BCM harness connector.
2. Check terminals for damage or loose connection.
3. Reconnect harness connector.

OK or NG

- OK >> GO TO 4.
- NG >> Repair or replace damaged parts.

4. CHECK TRANSMITTER ACTIVATION TOOL

Check transmitter activation tool battery.

OK or NG

- OK >> Carry out self-diagnosis.
- NG >> Replace battery in transmitter activation tool.

TROUBLE DIAGNOSES

Flash Code/Symptom Chart

EES002UV

A
B
C
D
WT
F
G
H
I
J
K
L
M

Flash Code or Symptom	Malfunction part	Reference page
15 16 17 18	FL tire pressure drops to 193 kPa (2.0 kg/cm ² , 28 psi) or less FR tire pressure drops to 193 kPa (2.0 kg/cm ² , 28 psi) or less RR tire pressure drops to 193 kPa (2.0 kg/cm ² , 28 psi) or less RL tire pressure drops to 193 kPa (2.0 kg/cm ² , 28 psi) or less	—
21 22 23 24	Transmitter no data (FL) Transmitter no data (FR) Transmitter no data (RR) Transmitter no data (RL)	WT-20
31 32 33 34	Transmitter checksum error (FL) Transmitter checksum error (FR) Transmitter checksum error (RR) Transmitter checksum error (RL)	WT-20
35 36 37 38	Transmitter pressure data error (FL) Transmitter pressure data error (FR) Transmitter pressure data error (RR) Transmitter pressure data error (RL)	WT-21
41 42 43 44	Transmitter function code error (FL) Transmitter function code error (FR) Transmitter function code error (RR) Transmitter function code error (RL)	WT-20
45 46 47 48	Transmitter battery voltage low (FL) Transmitter battery voltage low (FR) Transmitter battery voltage low (RR) Transmitter battery voltage low (RL)	WT-20
52	Vehicle speed signal	WT-22
Low tire pressure warning lamp does not come on when ignition switch is turned on.	<ul style="list-style-type: none"> ● Fuse or combination meter ● BCM connector or circuit ● BCM 	WT-23
Low tire pressure warning lamp stays on when ignition switch is turned on.	<ul style="list-style-type: none"> ● Combination meter ● BCM connector or circuit ● BCM 	WT-23
Low tire pressure warning lamp flashes when ignition switch is turned on.	<ul style="list-style-type: none"> ● BCM harness connector or circuit ● BCM ● Transmitter's mode off ● ID registration not completed yet 	WT-25
Hazard warning lamps flash when ignition switch is turned on.	<ul style="list-style-type: none"> ● BCM harness connector or circuit ● BCM 	WT-26
ID registration cannot be completed.	<ul style="list-style-type: none"> ● Transmitter ● Remote keyless entry receiver harness connector or circuit ● Remote keyless entry receiver ● BCM harness connector or circuit ● BCM 	WT-26

TROUBLE DIAGNOSIS FOR SELF-DIAGNOSTIC ITEMS

TROUBLE DIAGNOSIS FOR SELF-DIAGNOSTIC ITEMS

PF0:0000

Data From Transmitter Not Being Received

MALFUNCTION CODE NO. 21, 22, 23 OR 24 (DTC C1708, C1709, C1710 OR C1711)

EES002UW

1. CHECK BCM

Drive for several minutes. Check all tire pressures with CONSULT-II.

Are all tire pressures displayed as 0 kPa?

YES >> GO TO 2.

NO >> GO TO 3.

2. CHECK REMOTE KEYLESS ENTRY RECEIVER CONNECTOR

Check remote keyless entry receiver connector for damage or loose connections.

OK or NG

OK >> Replace BCM, then GO TO 3. Refer to [BCS-25, "Removal and Installation of BCM"](#) .

NG >> Repair or replace remote keyless entry receiver connector.

3. PERFORM ID REGISTRATION

Carry out ID registration of all transmitters. Refer to [WT-12, "ID Registration Procedure"](#) .

Is there a tire that cannot register ID?

YES >> Replace transmitter of the tire, then GO TO 5. Refer to [WT-27, "Transmitter \(Pressure Sensor\)"](#) .

NO >> GO TO 4.

4. DRIVE VEHICLE

1. Drive at a speed of 40 km/h (25 MPH) or more for several minutes without stopping.

2. Check all tire pressures with CONSULT-II within 15 minutes after vehicle speed becomes 17 km/h (11 MPH).

Does "DATA MONITOR ITEM" display tire pressure as normal without any warning lamp?

YES >> Inspection End.

NO >> GO TO 5.

5. ID REGISTRATION AND VEHICLE DRIVING

1. Carry out ID registration of all transmitters. Refer to [WT-12, "ID Registration Procedure"](#) .

2. Drive at a speed of 40 km/h (25 MPH) or more for 3 minutes, and then drive the vehicle at any speed for 10 minutes.

3. Check all tire pressures with CONSULT-II within 5 minutes.

Does "DATA MONITOR ITEM" display tire pressure as normal without any warning lamp?

YES >> Inspection End.

NO >> GO TO the inspection applicable to DTC.

Transmitter Malfunction

MALFUNCTION CODE NO. 31, 32, 33, 34, 41, 42, 43, 44, 45, 46, 47 OR 48

EES002UX

1. PERFORM ID REGISTRATION

1. Carry out ID registration of all transmitters. Refer to [WT-12, "ID Registration Procedure"](#) .

2. Drive at a speed of 40 km/h (25 MPH) or more for 3 minutes, and then drive the vehicle at any speed for 10 minutes.

>> GO TO 2.

TROUBLE DIAGNOSIS FOR SELF-DIAGNOSTIC ITEMS

2. REPLACE TRANSMITTER

1. Check low tire pressure warning lamp again for flashing, replace malfunctioning transmitter. Refer to [WT-27, "Transmitter \(Pressure Sensor\)"](#) .
 2. Carry out ID registration of all transmitters. Refer to [WT-12, "ID Registration Procedure"](#) .
- Can ID registration of all transmitters be completed?

YES >> GO TO 3.

NO >> GO TO [WT-20, "Data From Transmitter Not Being Received"](#) .

3. DRIVE VEHICLE

1. Drive at a speed of 40 km/h (25 MPH) or more for 3 minutes, and then drive the vehicle at any speed for 10 minutes.
2. Check all tire pressures with CONSULT-II within 5 minutes.

Does "DATA MONITOR ITEM" display tire pressure as normal without any warning lamp?

YES >> Inspection End.

NO >> Replace malfunctioning transmitter, and perform Step 3 again. Refer to [WT-27, "Transmitter \(Pressure Sensor\)"](#) .

Transmitter Pressure Malfunction MALFUNCTION CODE NO. 35, 36, 37 OR 38

EES002UY

1. CHECK ALL TIRE PRESSURES

Check all tire pressures. Refer to [WT-29, "Tire"](#) .

Are there any tires with pressure of 64 psi or more?

YES >> Adjust tire pressure to specified value.

NO >> GO TO 2.

2. ID REGISTRATION AND VEHICLE DRIVING

1. Carry out ID registration of all transmitters. Refer to [WT-12, "ID Registration Procedure"](#) .
2. Drive at a speed of 40 km/h (25 MPH) or more for several minutes without stopping.
3. Check all tire pressures with CONSULT-II within 15 minutes after vehicle speed becomes 17 km/h (11 MPH).

Does "DATA MONITOR ITEM" display 64 psi or more?

YES >> Replace transmitter. Refer to [WT-27, "Transmitter \(Pressure Sensor\)"](#) . GO TO 3.

NO >> GO TO 3.

3. ID REGISTRATION AND VEHICLE DRIVING

1. Carry out ID registration of all transmitters. Refer to [WT-12, "ID Registration Procedure"](#) .
2. Drive at a speed of 40 km/h (25 MPH) or more for 3 minutes, and then drive the vehicle at any speed for 10 minutes.
3. Check all tire pressures with CONSULT-II within 5 minutes.

Does "DATA MONITOR ITEM" display tire pressure as normal without any warning lamp?

YES >> Inspection End.

NO >> GO TO the inspection applicable to DTC.

TROUBLE DIAGNOSIS FOR SELF-DIAGNOSTIC ITEMS

Vehicle Speed Signal MALFUNCTION CODE NO. 52 (DTC C1729)

EES002UZ

1. SELF-DIAGNOSTIC RESULT CHECK

Using CONSULT-II, check display contents in self-diagnostic results.

Is "CAN COMM CIRCUIT" displayed in the self-diagnosis display items?

- YES >> Malfunction in CAN communication system. GO TO [LAN-44, "TROUBLE DIAGNOSIS"](#) .
- NO >> GO TO 2.

2. CHECK BCM

Perform BCM diagnosis. Refer to [BCS-17, "CONSULT-II Function \(BCM\)"](#) .

Inspection results OK?

- OK >> Perform Vehicle Speed Sensor Inspection. Refer to [AT-115, "Diagnostic Procedure"](#) .
- NG >> Replace BCM. Refer to [BCS-25, "Removal and Installation of BCM"](#) .

TROUBLE DIAGNOSIS FOR SYMPTOMS

TROUBLE DIAGNOSIS FOR SYMPTOMS

PF0:0007

Low Tire Pressure Warning Lamp Does Not Come On When Ignition Switch Is Turned On

EES002V0

DIAGNOSTIC PROCEDURE

1. SELF-DIAGNOSTIC RESULT CHECK

Using CONSULT-II, check display contents in self-diagnostic results.

Is "CAN COMM CIRCUIT" displayed in the self-diagnosis display items?

- YES >> Malfunction in CAN communication system. GO TO [LAN-44, "TROUBLE DIAGNOSIS"](#).
- NO >> GO TO 2.

2. CHECK COMBINATION METER

Check combination meter operation. Refer to [DI-11, "Self-Diagnosis Mode of Combination Meter"](#).

Inspection results OK?

- OK >> GO TO 3.
- NG >> Replace combination meter. Refer to [IP-13, "COMBINATION METER"](#).

3. CHECK LOW TIRE PRESSURE WARNING LAMP

Disconnect BCM harness connector.

Does the low tire pressure warning lamp activate?

- YES >> Replace BCM. Refer to [BCS-25, "Removal and Installation of BCM"](#).
- NO >> Check combination meter operation. Refer to [DI-11, "Self-Diagnosis Mode of Combination Meter"](#).

Low Tire Pressure Warning Lamp Stays On When Ignition Switch Is Turned On

EES002V1

DIAGNOSTIC PROCEDURE

1. CHECK BCM CONNECTORS

1. Turn ignition switch OFF.
2. Disconnect BCM harness connectors M18 and M20.
3. Check terminals for damage or loose connections.

Inspection results OK?

- OK >> GO TO 2.
- NG >> Repair or replace damaged parts.

2. CHECK BCM POWER SUPPLY CIRCUIT (BAT)

Check voltage between BCM harness connector M20 terminal 70 and ground.

Terminals		Voltage (Approx.)
(+)	(-)	
Connector	Terminal	Ground
M20	70	Battery voltage

OK or NG

- OK >> GO TO 3.
- NG >> Check BCM power supply circuit for open or short.

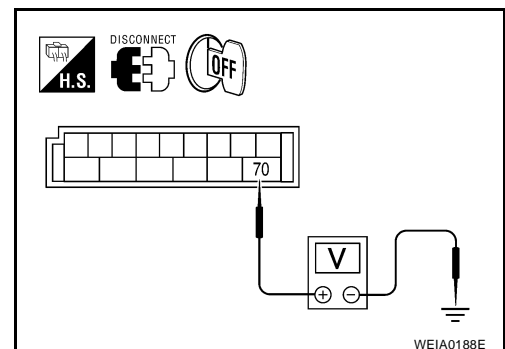

TROUBLE DIAGNOSIS FOR SYMPTOMS

3. CHECK BCM POWER SUPPLY CIRCUIT (IGN)

1. Turn ignition switch ON.
2. Check voltage between BCM harness connector M18 terminal 38 and ground.

Terminals		Voltage (Approx.)
(+)	(-)	
Connector	Terminal	Ground
M18	38	

OK or NG

- OK >> GO TO 4.
 NG >> Check BCM power supply circuit for open or short.

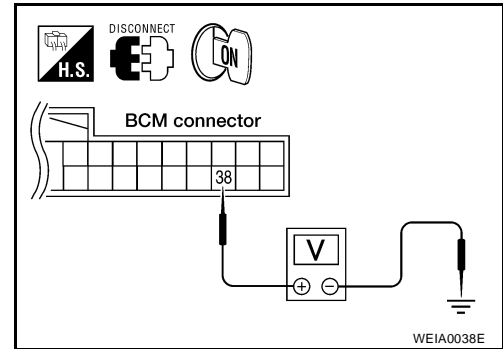

4. CHECK BCM GROUND CIRCUIT

1. Turn ignition switch OFF.
2. Check continuity between BCM harness connector M20 terminal 67 and ground.

Terminals		Continuity
(+)	(-)	
Connector	Terminal	Ground
M20	67	

OK or NG

- OK >> Replace BCM. Refer to [BCS-25, "Removal and Installation of BCM"](#) .
 NG >> Repair BCM ground circuit.

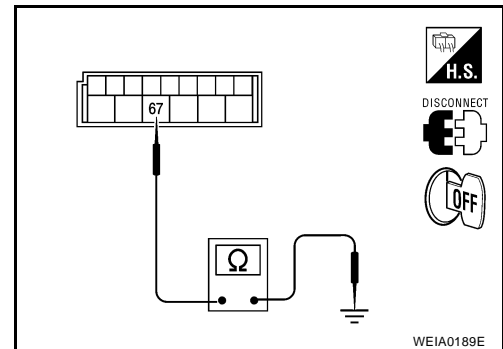

TROUBLE DIAGNOSIS FOR SYMPTOMS

Low Tire Pressure Warning Lamp Flashes When Ignition Switch Is Turned On

EES002V2

NOTE:

If low tire pressure warning lamp flashes as shown, the system is normal.

Flash Mode A

- This mode shows transmitter status is OFF-mode. Carry out transmitter wake up operation. Refer to [WT-14, "Transmitter Wake Up Operation"](#).

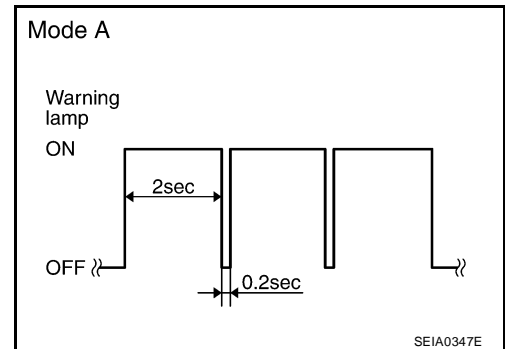

DIAGNOSTIC PROCEDURE

1. CHECK BCM CONNECTORS

- Turn ignition switch OFF.
- Disconnect BCM harness connectors M18 and M20.
- Check terminals for damage or loose connections.

Inspection results OK?

- OK >> GO TO 2.
NG >> Repair or replace damaged parts.

2. CHECK TIRE PRESSURE WARNING CHECK CONNECTOR CIRCUIT

Check continuity between BCM harness connector M18 terminal 15 and check connector M123 terminal 1.

Continuity should exist.

OK or NG

- OK >> Replace BCM. Refer to [BCS-25, "Removal and Installation of BCM"](#).
- NG >> Repair or replace harness connector.

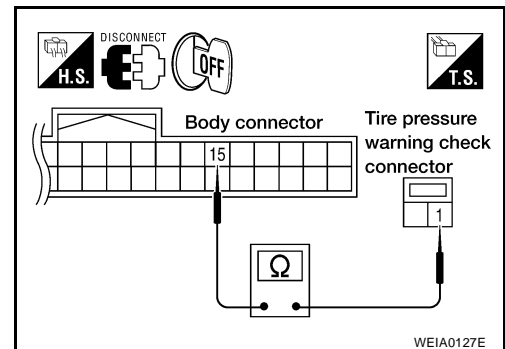

TROUBLE DIAGNOSIS FOR SYMPTOMS

Hazard Warning Lamps Flash When Ignition Switch Is Turned On

EES002V3

DIAGNOSTIC PROCEDURE

1. CHECK BCM GROUND CIRCUIT

1. Turn ignition switch OFF.
2. Disconnect BCM harness connector M20.
3. Check continuity between BCM harness connector M20 terminal 67 and ground.

Terminals		Continuity	
(+)	(-)		
Connector	Terminal	Ground	Yes
M20	67		

OK or NG

- OK >> Replace BCM. Refer to [BCS-25, "Removal and Installation of BCM"](#).
- NG >> Repair BCM ground circuit.

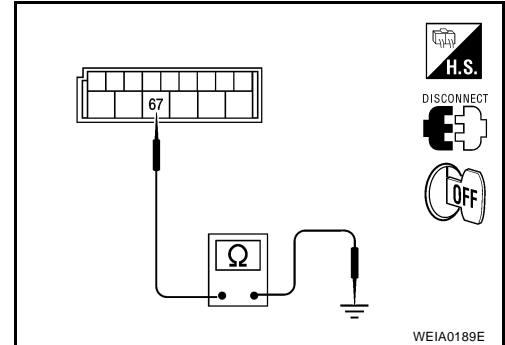

ID Registration Cannot Be Completed

EES002V4

DIAGNOSTIC PROCEDURE

1. PERFORM ID REGISTRATION OF ALL TRANSMITTERS

Carry out ID registration of all transmitters. Refer to [WT-12, "ID Registration Procedure"](#).

Can ID registration of all transmitters be completed?

- YES >> Inspection End.
- NO >> GO TO [WT-20, "Data From Transmitter Not Being Received"](#).

REMOVAL AND INSTALLATION

REMOVAL AND INSTALLATION

PFP:00000

EES001S3

Transmitter (Pressure Sensor) REMOVAL

1. Remove wheel and tire using power tool.
2. Deflate tire. Unscrew transmitter retaining nut and allow transmitter to fall into tire.
3. Gently bounce tire so that transmitter falls to bottom of tire. Place wheel and tire assembly on tire changing machine and break both tire beads. Ensure that the transmitter remains at the bottom of the tire while breaking the bead.

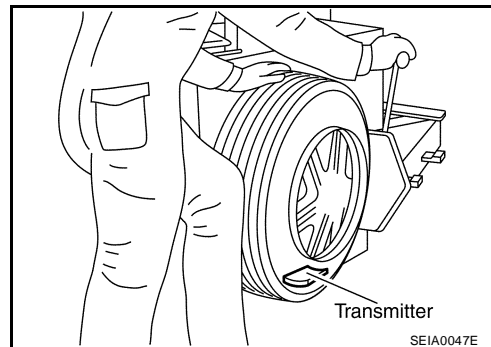

4. Turn tire so that valve hole is at bottom, and gently bounce the tire to ensure transmitter is near valve hole. Carefully lift tire onto turntable and position valve hole (and transmitter) 270 degrees from mounting/dismounting head.
5. Lubricate tire well, and remove top side of tire. Reach inside the tire and remove the transmitter.
6. Remove the second side of the tire as normal.

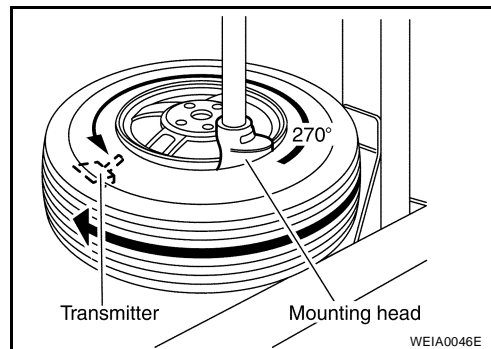

INSTALLATION

1. Place first side of tire onto rim.

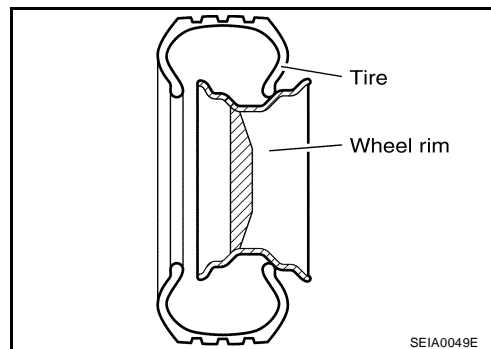

2. Apply suitable silicone lubricant to new transmitter seal then install seal on transmitter. Refer to [MA-11, "RECOMMENDED FLUIDS AND LUBRICANTS"](#).

NOTE:

Always replace the seal after every disassembly.

3. Mount transmitter on rim and tighten nut to specification.

NOTE:

Make sure no burrs exist in the valve stem hole of the wheel.

Transmitter nut : 5.5 N-m (0.56 kg-m, 49 in-lb)

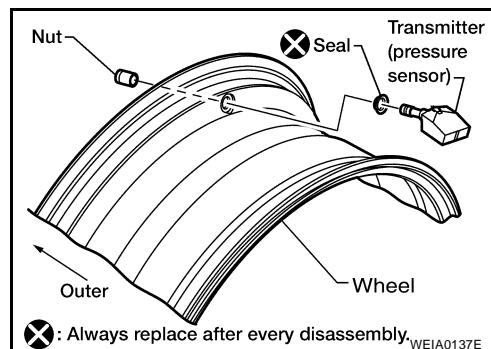

⊗: Always replace after every disassembly.

REMOVAL AND INSTALLATION

- Place wheel on turntable of tire machine. Ensure that transmitter is 270 degrees from mounting/dismounting head.

NOTE:

Do not touch transmitter with mounting head.

- Lubricate tire well, and install second side of tire as normal. Ensure that tire does not rotate relative to rim.
- Inflate tire and balance the wheel and tire assembly. Refer to [WT-6, "WHEEL BALANCE INSTALLATION AND ADJUSTMENT"](#).
- Install wheel and tire assembly in appropriate wheel position on vehicle.

NOTE:

If replacing transmitter, transmitter wake up operation must be performed. Refer to [WT-14, "Transmitter Wake Up Operation"](#).

- Adjust neutral position of steering angle sensor. Refer to [BRC-56, "Adjustment of Steering Angle Sensor Neutral Position"](#).

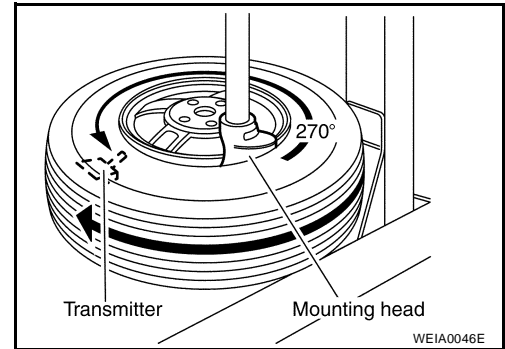

SERVICE DATA AND SPECIFICATIONS (SDS)

SERVICE DATA AND SPECIFICATIONS (SDS)

PFP:00030

Road Wheel

EES001S4

Wheel type	Aluminum	
Maximum radial runout limit	Lateral mm (in)	0.3 (0.012) or less
	Radial mm (in)	0.3 (0.012) or less
Maximum residual imbalance	Dynamic (at rim flange)	Less than 5 g (0.18 oz) (per side)
	Static (at rim flange)	Less than 10 g (0.35 oz)

Tire

EES001S5

Unit: kPa (kg/cm², psi)

Tire size	Air pressure	
	Conventional tire	Spare tire
Full size spare tire	—	240 (2.4, 35)
P265/70R16	240 (2.4, 35)	—
P265/75R16	240 (2.4, 35)	—
P265/65R17	240 (2.4, 35)	—

A
B
C
D
WT
F
G
H
I
J
K
L
M

SERVICE DATA AND SPECIFICATIONS (SDS)
