

SECTION **FFD**  
FRONT FINAL DRIVE

A  
B  
C

FFD

CONTENTS

E

|   |           |  |           |   |
|---|-----------|--|-----------|---|
| <b>PRECAUTIONS</b> .....                          | <b>2</b>  | <b>CARRIER COVER</b> .....                         | <b>12</b> | F |
| Precautions for Servicing Front Final Drive ..... | 2         | Removal and Installation .....                     | 12        |   |
| <b>PREPARATION</b> .....                          | <b>3</b>  | REMOVAL .....                                      | 12        |   |
| Special Service Tools .....                       | 3         | INSTALLATION .....                                 | 12        | G |
| Commercial Service Tools .....                    | 5         | <b>FRONT FINAL DRIVE ASSEMBLY</b> .....            | <b>13</b> |   |
| <b>NOISE, VIBRATION AND HARSHNESS (NVH)</b>       |           | Removal and Installation .....                     | 13        |   |
| <b>TROUBLESHOOTING</b> .....                      | <b>6</b>  | REMOVAL .....                                      | 13        | H |
| NVH Troubleshooting Chart .....                   | 6         | INSTALLATION .....                                 | 14        |   |
| <b>DESCRIPTION</b> .....                          | <b>7</b>  | Disassembly and Assembly .....                     | 15        |   |
| Cross-Sectional View .....                        | 7         | COMPONENTS .....                                   | 15        | I |
| <b>DIFFERENTIAL GEAR OIL</b> .....                | <b>8</b>  | ASSEMBLY INSPECTION AND ADJUSTMENT..               | 16        |   |
| Changing Differential Gear Oil .....              | 8         | DISASSEMBLY .....                                  | 18        |   |
| DRAINING .....                                    | 8         | INSPECTION AFTER DISASSEMBLY .....                 | 23        | J |
| FILLING .....                                     | 8         | ADJUSTING AND SELECTING WASHERS .....              | 24        |   |
| Checking Differential Gear Oil .....              | 8         | ASSEMBLY .....                                     | 28        |   |
| DIFFERENTIAL GEAR OIL LEAKAGE AND                 |           | <b>SERVICE DATA AND SPECIFICATIONS (SDS)</b> ..... | <b>34</b> |   |
| LEVEL .....                                       | 8         | General Specifications .....                       | 34        | K |
| <b>FRONT OIL SEAL</b> .....                       | <b>9</b>  | Inspection and Adjustment .....                    | 34        |   |
| Removal and Installation .....                    | 9         | DRIVE GEAR RUNOUT .....                            | 34        | L |
| REMOVAL .....                                     | 9         | SIDE GEAR CLEARANCE .....                          | 34        |   |
| INSTALLATION .....                                | 10        | PRELOAD TORQUE .....                               | 34        |   |
| <b>SIDE OIL SEAL</b> .....                        | <b>11</b> | BACKLASH .....                                     | 34        |   |
| Removal and Installation .....                    | 11        | COMPANION FLANGE RUNOUT .....                      | 34        | M |
| REMOVAL .....                                     | 11        | SELECTIVE PARTS .....                              | 35        |   |
| INSTALLATION .....                                | 11        |  |           |   |

# PRECAUTIONS

---

## PRECAUTIONS

PFP:00001

### Precautions for Servicing Front Final Drive

EDS0045Y

- Before starting diagnosis of the vehicle, understand the symptoms well. Perform correct and systematic operations.
- Check for the correct installation status prior to removal or disassembly. When matching marks are required, be certain they do not interfere with the function of the parts they are applied to.
- Overhaul should be done in a clean work area, a dust proof area is recommended.
- Before disassembly, completely remove sand and mud from the exterior of the unit, preventing them from entering into the unit during disassembly or assembly.
- Always use shop paper for cleaning the inside of components.
- Avoid using cotton gloves or a shop cloth to prevent the entering of lint.
- Check appearance of the disassembled parts for damage, deformation, and abnormal wear. Replace them with new ones if necessary.
- Gaskets, seals and O-rings should be replaced any time the unit is disassembled.
- Clean and flush the parts sufficiently and blow them dry.
- Be careful not to damage sliding surfaces and mating surfaces.
- When applying sealant, remove the old sealant from the mating surface; then remove any moisture, oil, and foreign materials from the application and mating surfaces.
- In principle, tighten nuts or bolts gradually in several steps working diagonally from inside to outside. If a tightening sequence is specified, observe it.
- During assembly, observe the specified tightening torque.
- Add new differential gear oil, petroleum jelly, or multi-purpose grease, as specified.

# PREPARATION

## PREPARATION

PF0:00002

### Special Service Tools

EDS0045Z

The actual shapes of Kent-Moore tools may differ from those of special service tools illustrated here.

| Tool number<br>(Kent-Moore No.)<br>Tool name  | Description  |
|---|--|
| KV38108300<br>(J-44195)<br>Flange wrench  | Removing and installing drive pinion lock nut  |
| KV381054S0<br>(J-34286)<br>Puller   | Removing front oil seal  |
| ST30720000<br>(J-25405)<br>Drift  | <ul style="list-style-type: none"> <li>● Installing front oil seal</li> <li>● Installing side oil seal</li> </ul> a: 77 mm (3.03 in) dia.<br>b: 55.5 mm (2.185 in) dia.    |
| ST27863000<br>( — )<br>Drift  | <ul style="list-style-type: none"> <li>● Installing front oil seal</li> <li>● Installing side oil seal</li> </ul> a: 74.5 mm (2.933 in) dia.<br>b: 62.5 mm (2.461 in) dia. |
| ST3127S000<br>(J-25765-A)<br>Preload gauge<br>1: GG91030000<br>(J-25765)<br>Torque wrench<br>2: HT62940000<br>( — )<br>Socket adapter (1/2")<br>3: HT62900000<br>( — )<br>Socket adapter (3/8") | Measuring drive pinion bearing preload torque and total preload torque   |
| KV10111100<br>(J-37228)<br>Seal cutter  | Removing carrier cover   |

A  
B  
C  
FFD  
E  
F  
G  
H  
I  
J  
K  
L  
M

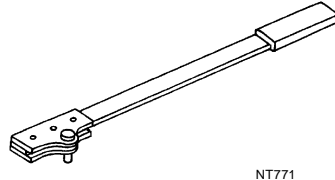

NT771

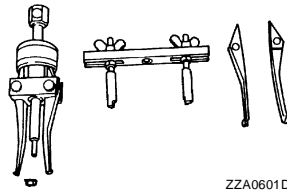

ZZA0601D

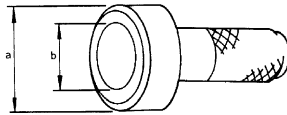

ZZA0811D

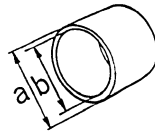

ZZA1003D

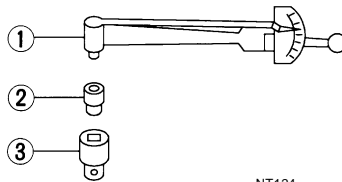

NT124

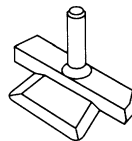

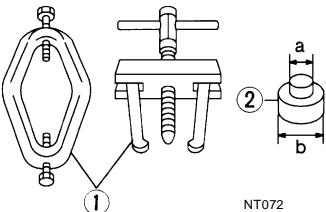
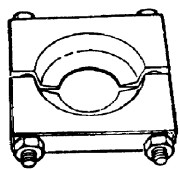
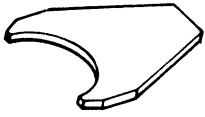
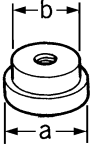
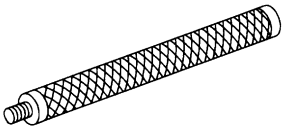
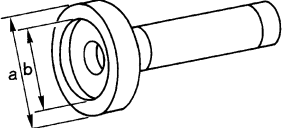
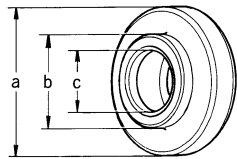

S-NT046

# PREPARATION

| Tool number<br>(Kent-Moore No.)<br>Tool name  | Description  |
|---|--|
| ST3306S001<br>( — )<br>Differential side bearing puller set<br>1: ST33051001<br>(J-22888-20)<br>Puller<br>2: ST33061000<br>(J-8107-2)<br>Base |  Removing and installing side bearing inner race<br><b>a: 28.5 mm (1.122 in) dia.</b><br><b>b: 38 mm (1.50 in) dia.</b>                                     |
| ST30031000<br>(J-22912-01)<br>Replacer  |  Removing drive pinion rear bearing inner race  |
| KV38100600<br>(J-25267)<br>Drift  |  Installing side bearing adjusting washer   |
| ST30613000<br>(J-25742-3)<br>Drift  |  Installing drive pinion rear bearing outer race<br><b>a: 72 mm (2.83 in) dia.</b><br><b>b: 48 mm (1.89 in) dia.</b>                                      |
| ST30611000<br>(J-25742-1)<br>Drift bar  |  Installing drive pinion rear bearing outer race<br>(Use with ST30613000)   |
| KV38100200<br>(J-26233)<br>Drift  |  Installing drive pinion front bearing outer race<br><b>a: 65 mm (2.56 in) dia.</b><br><b>b: 49 mm (1.93 in) dia.</b>                                     |
| ST30901000<br>(J-26010-01)<br>Drift   |  Installing drive pinion rear bearing inner race<br><b>a: 79 mm (3.11 in) dia.</b><br><b>b: 45 mm (1.77 in) dia.</b><br><b>c: 35.2 mm (1.386 in) dia.</b> |

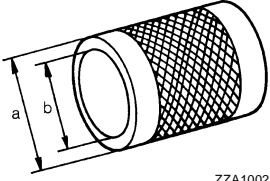
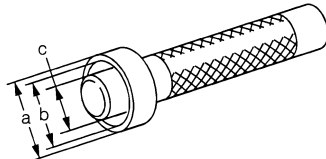
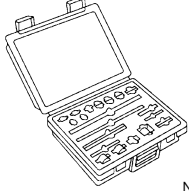
# PREPARATION

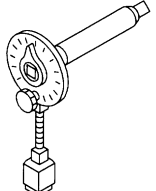
| Tool number<br>(Kent-Moore No.)<br>Tool name   | Description  |
|--|--|
| ST33200000<br>(J-26082)<br>Drift<br><br>ZZA1002D                    | Installing drive pinion front bearing inner race<br><b>a: 60 mm (2.36 in) dia.</b><br><b>b: 44.5 mm (1.752 in) dia.</b>                  |
| ST33230000<br>(J-35867)<br>Drift<br><br>ZZA1046D                    | Installing side bearing inner race<br><b>a: 51 mm (2.01 in) dia.</b><br><b>b: 41 mm (1.61 in) dia.</b><br><b>c: 28 mm (1.10 in) dia.</b> |
| ( — )<br>(J-34309)<br>Differential shim selector tool<br><br>NT134  | Adjusting bearing preload and drive pinion height  |
| ( — )<br>(J-25269-18)<br>Side bearing disc (2 Req'd)<br><br>NT135 | Selecting drive pinion height adjusting washer   |
| KV10112100<br>(BT-8653-A)<br>Angle wrench<br><br>NT014            | Tightening bolts for drive gear  |

## Commercial Service Tools

EDS00460

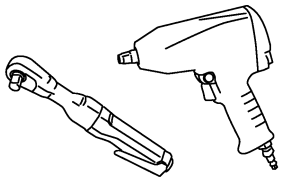
| Tool name  | Description              |
|--|--------------------------|
| Power tool<br><br>PBIC0190E | Loosening nuts and bolts |

# NOISE, VIBRATION AND HARSHNESS (NVH) TROUBLESHOOTING

## NOISE, VIBRATION AND HARSHNESS (NVH) TROUBLESHOOTING

PF0:00003

### NVH Troubleshooting Chart

EDS00461

Use the chart below to help you find the cause of the symptom. If necessary, repair or replace these parts.

| Symptom                            | Noise |   |                        |                        |                        |                        |                                   |                       |                 |   |  |  |   |   |  |   |   |
|------------------------------------|-------|---|------------------------|------------------------|------------------------|------------------------|-----------------------------------|-----------------------|-----------------|---|--|--|---|---|--|---|---|
| Reference page                     |       |   | <a href="#">FFD-17</a> | <a href="#">FFD-17</a> | <a href="#">FFD-17</a> | <a href="#">FFD-18</a> | <a href="#">FFD-18</a>            | <a href="#">FFD-8</a> |                 | <a href="#">PR-3, "NVH Troubleshooting Chart"</a> | <a href="#">FFD-6, "NVH Troubleshooting Chart"</a> | <a href="#">FSU-4, "NVH Troubleshooting Chart"</a> | <a href="#">WT-4, "NVH Troubleshooting Chart"</a> | <a href="#">WT-4, "NVH Troubleshooting Chart"</a> | <a href="#">FAX-4, "NVH Troubleshooting Chart"</a> | <a href="#">BR-5, "NVH Troubleshooting Chart"</a> | <a href="#">PS-5, "NVH Troubleshooting Chart"</a> |
| Possible cause and SUSPECTED PARTS |       |   | Gear tooth rough       | Gear contact improper  | Tooth surfaces worn    | Backlash incorrect     | Companion flange excessive runout | Gear oil improper     | PROPELLER SHAFT | FRONT AXLE  | FRONT SUSPENSION                                   | TIRES  | ROAD WHEEL  | DRIVE SHAFT                                       | BRAKES   | STEERING  |   |
|                                    |       | x | x                      | x                      | x                      | x                      | x                                 | x                     | x               | x   | x  | x  | x   | x   | x  | x   | x   |

x: Applicable

# DESCRIPTION

## DESCRIPTION

PF0:0000

### Cross-Sectional View

EDS00462

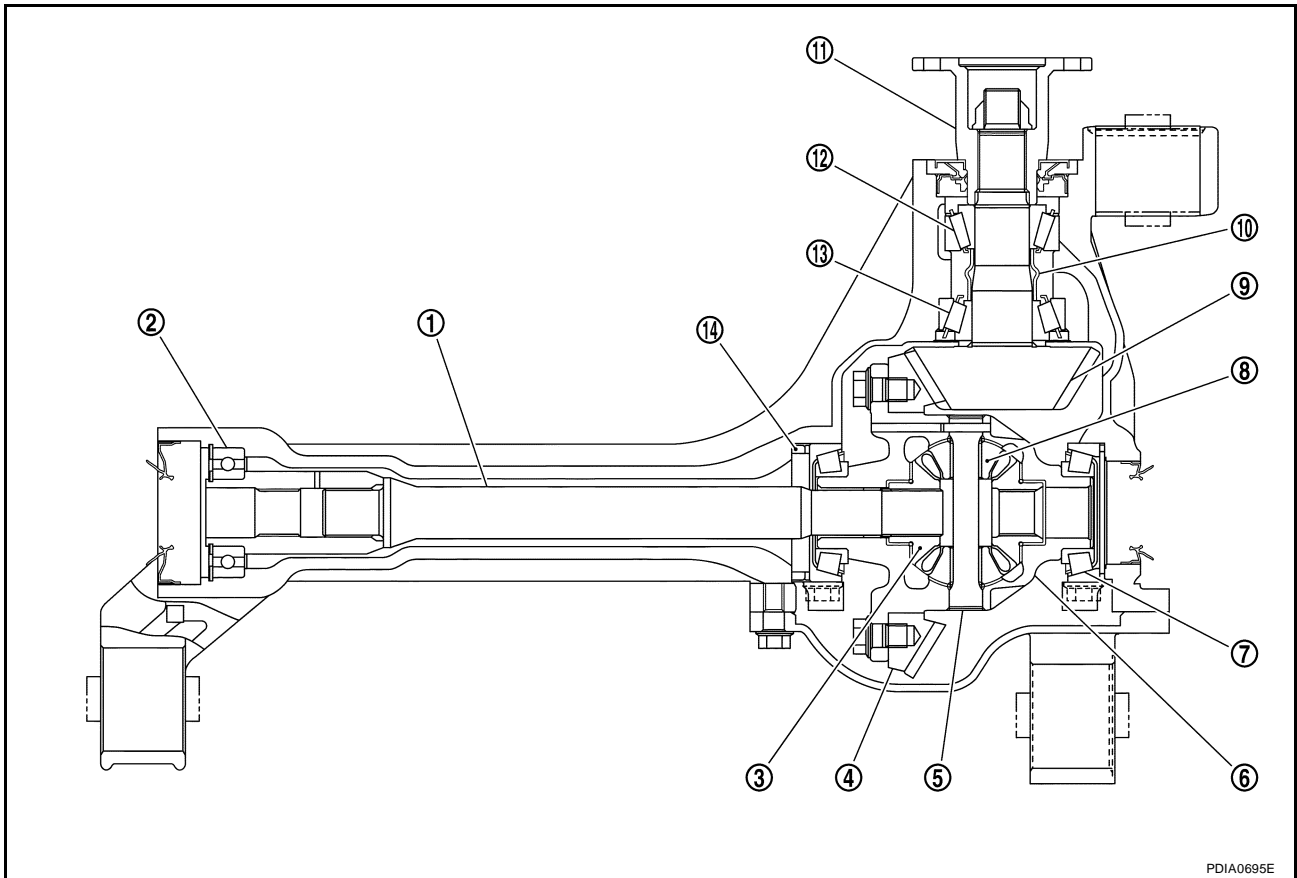

- |                               |                                    |                                |
|-------------------------------|------------------------------------|--------------------------------|
| 1. Differential side shaft    | 2. Differential side shaft bearing | 3. Side gear                   |
| 4. Drive gear                 | 5. Pinion mate shaft               | 6. Differential case           |
| 7. Side bearing               | 8. Pinion mate gear                | 9. Drive pinion                |
| 10. Collapsible spacer        | 11. Companion flange               | 12. Drive pinion front bearing |
| 13. Drive pinion rear bearing | 14. Housing spacer                 |                                |

A  
B  
C  
FFD  
E  
F  
G  
H  
I  
J  
K  
L  
M

# DIFFERENTIAL GEAR OIL

PFP:KLD30

EDS00463

## DIFFERENTIAL GEAR OIL

### Changing Differential Gear Oil DRAINING

1. Stop the engine.
2. Remove the drain plug and gasket from the front final drive assembly to drain the differential gear oil.
3. Install the drain plug with a new gasket to the front final drive assembly. Tighten to the specified torque. Refer to [FFD-15, "COMPONENTS"](#).

**CAUTION:**

**Do not reuse gasket.**

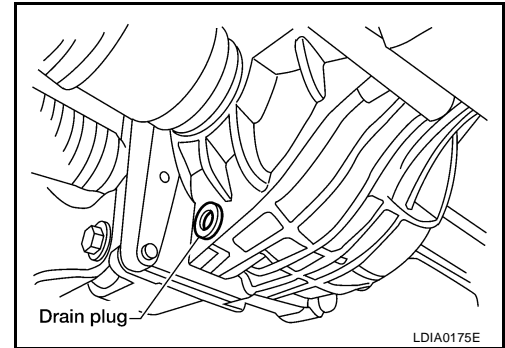

### FILLING

1. Remove the filler plug and gasket from the front final drive assembly.
2. Fill the front final drive assembly with new differential gear oil until the level reaches the specified level near the filler plug hole.

**Differential gear oil grade and capacity** : Refer to [MA-11, "Fluids and Lubricants"](#).

3. Install the filler plug with a new gasket on it to the front final drive assembly. Tighten to the specified torque. Refer to [FFD-15, "COMPONENTS"](#).

**CAUTION:**

**Do not reuse gasket.**

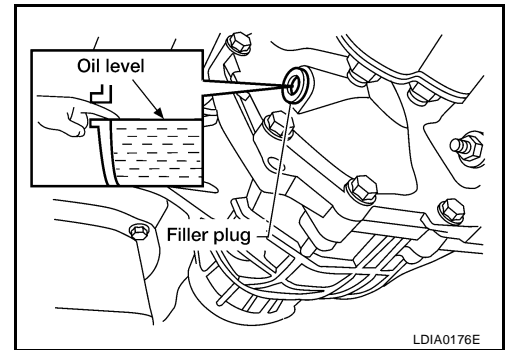

### Checking Differential Gear Oil DIFFERENTIAL GEAR OIL LEAKAGE AND LEVEL

EDS00464

1. Make sure that differential gear oil is not leaking from the front final drive assembly or around it.
2. Check the differential gear oil level from the filler plug hole as shown.

**CAUTION:**

**Do not start engine while checking differential gear oil level.**

3. Install the filler plug with a new gasket on it to the front final drive assembly. Tighten to the specified torque. Refer to [FFD-15, "COMPONENTS"](#).

**CAUTION:**

**Do not reuse gasket.**

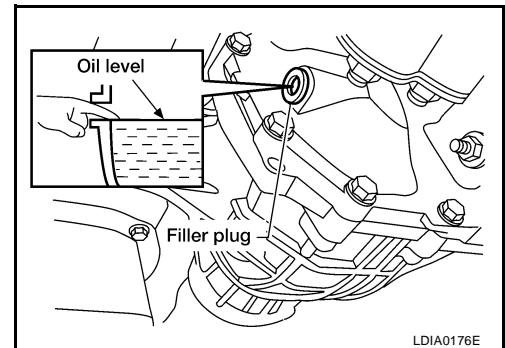



# FRONT OIL SEAL

PF3:38189

## FRONT OIL SEAL

### Removal and Installation

EDS00465

1. Remove the drive shafts from the front final drive assembly. Refer to [FAX-7, "Removal and Installation"](#) .
2. Remove the front propeller shaft from the front final drive assembly. Refer to [PR-5, "Removal and Installation"](#) .
3. Measure the total preload torque. Refer to [FFD-16, "Total Preload Torque"](#) .

#### NOTE:

Record the total preload torque measurement.

4. Remove the drive pinion lock nut using Tool.

**Tool number** : KV38108300 ( — )

5. Put matching marks on the companion flange and drive pinion using paint.

#### CAUTION:

**Use paint to make the matching marks. Do not damage the companion flange or drive pinion.**

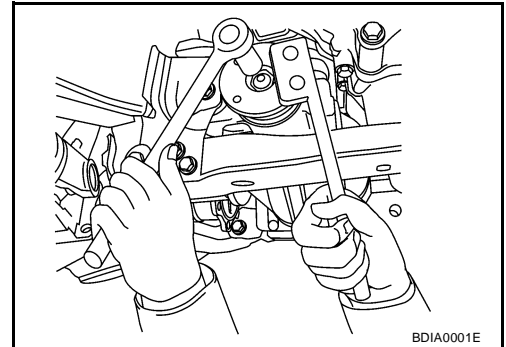

6. Remove the companion flange using suitable tool.

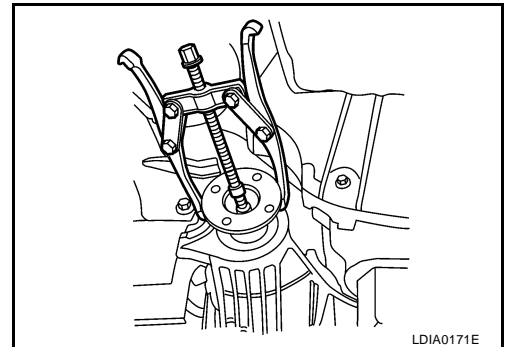

7. Remove the front oil seal using Tool.

**Tool number** : KV381054S0 (J-34286)

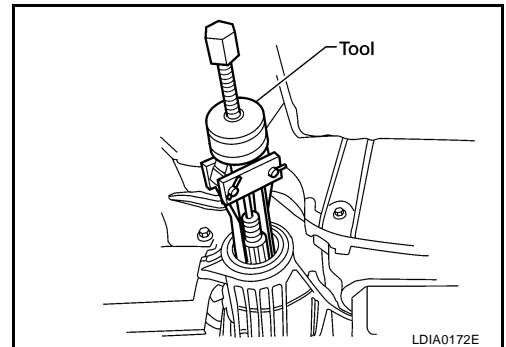

A  
B  
C  
FFD

E  
F  
G  
H  
I  
J  
K  
L  
M

# FRONT OIL SEAL

## INSTALLATION

1. Apply multi-purpose grease to the lips and differential gear oil to the circumference of the new front oil seal. Then drive the new front oil seal in evenly until it becomes flush with the gear carrier using Tools.

**Tool number**     **A: ST30720000 (J-25405)**  
                          **B: ST27863000 ( — )**

### CAUTION:

- Do not reuse front oil seal.
- Do not incline the new front oil seal when installing.
- Apply multi-purpose grease to the lips and differential gear oil to the circumference of the new front oil seal.

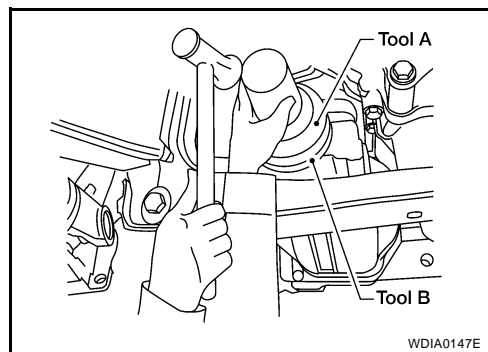

2. Install the companion flange to the drive pinion while aligning the matching marks.
3. Apply anti-corrosive oil to the threads of the drive pinion and the seating surface of the new drive pinion lock nut. Then adjust the drive pinion lock nut tightening torque using Tool A, and check the total preload torque using Tool B.

**Tool number**     **A: KV38108300 ( — )**  
                          **B: ST3127S000 (J-25765-A)**

**Total preload torque:** Refer to [FFD-16, "Total Preload Torque"](#) .

- The total preload torque should be within the total preload torque specification. When not replacing the collapsible spacer, it should also be equal to the measurement taken during removal plus an additional 0.56 N·m (0.06 Kg·m, 5 in·lb).
- If the total preload torque is low, tighten the drive pinion lock nut in 6.8 N·m (0.69 Kg·m, 5ft·lb) increments until the total preload torque is met.

### CAUTION:

- Do not reuse drive pinion lock nut.
- Apply anti-corrosive oil to the threads of the drive pinion and the seating surface of the new drive pinion lock nut.
- Adjust the drive pinion lock nut tightening torque to the lower limit first. Do not exceed the drive pinion lock nut specified torque. Refer to [FFD-15, "COMPONENTS"](#) .
- Do not loosen drive pinion lock nut to adjust the total preload torque. If the drive pinion lock nut torque or the total preload torque exceeds the specifications, replace the collapsible spacer and tighten it again to adjust. Refer to [FFD-15, "Disassembly and Assembly"](#) .
- After adjustment, rotate drive pinion back and forth 2 to 3 times to check for unusual noise, rotation malfunction, and other malfunctions.

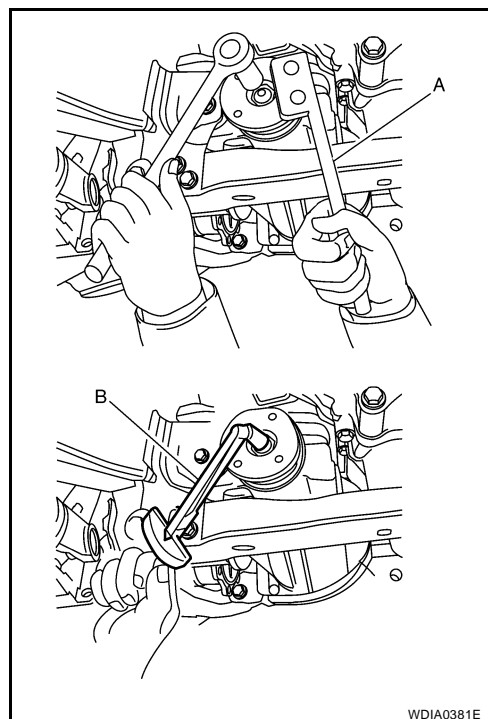

4. Install new side oil seals into the front final drive assembly. Refer to [FFD-11, "Removal and Installation"](#) .
5. Installation of the remaining components is in the reverse order of removal.

### CAUTION:

Check the differential gear oil level after installation. Refer to [FFD-8, "DIFFERENTIAL GEAR OIL"](#) .

# SIDE OIL SEAL

PF3:33142

## SIDE OIL SEAL

### Removal and Installation

EDS00466

1. Remove the drive shafts from the front final drive assembly. Refer to [FAX-7, "Removal and Installation"](#) .
2. Remove the side oil seal using suitable tool.

**CAUTION:**

**Do not reuse the side oil seal.**

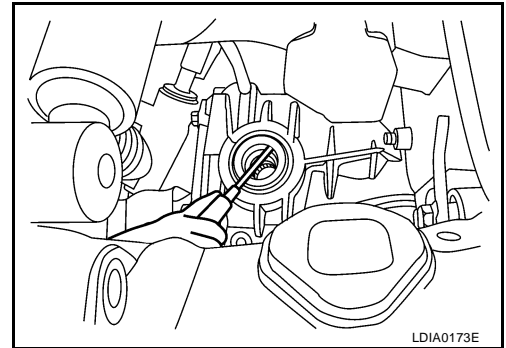

### INSTALLATION

1. Apply multi-purpose grease to the lips and differential gear oil to the circumference of the new side oil seal. Then drive the new side oil seal in evenly until it becomes flush with the gear carrier using Tools.

**Tool number**     **A: ST30720000 (J-25405)**  
                          **B: ST27863000 ( — )**

**CAUTION:**

- Do not reuse side oil seal.
- Do not incline the new side oil seal when installing.
- Apply multi-purpose grease to the lips and differential gear oil to the circumference of the new side oil seal.

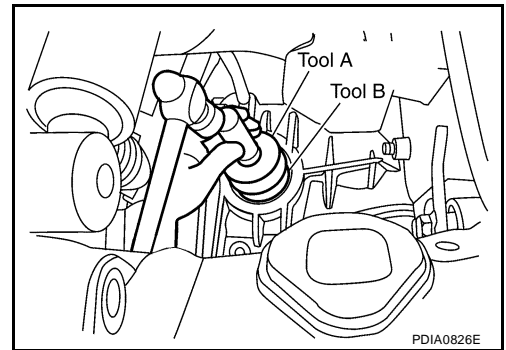

2. Installation of the remaining components is in the reverse order of removal.

**CAUTION:**

**Check the differential gear oil level after installation. Refer to [FFD-8, "Checking Differential Gear Oil"](#) .**

A  
B  
C  
FFD  
E  
F  
G  
H  
I  
J  
K  
L  
M

# CARRIER COVER

PF3:38351

EDS00467

## CARRIER COVER

### Removal and Installation

#### REMOVAL

1. Remove the front final drive assembly. Refer to [FFD-13, "Removal and Installation"](#).
2. Remove the carrier cover bolts and separate the carrier cover from the gear carrier using Tool.

**Tool number** : KV10111100 (J-37228)

#### CAUTION:

- Do not damage the mating surface.
- Do not insert flat-bladed screwdriver, this will damage the mating surface.

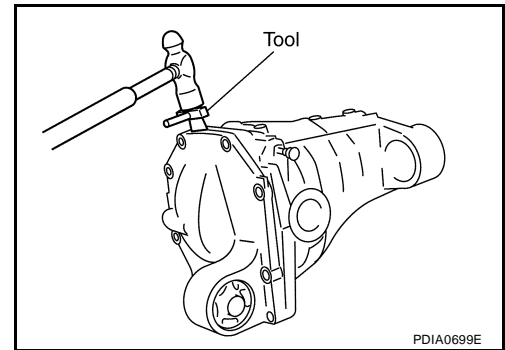

#### INSTALLATION

1. Apply a 3 mm (0.12 in) bead of sealant to the mating surface of the carrier cover as shown.
  - Use Genuine Silicone RTV or equivalent. Refer to [GI-47, "Recommended Chemical Products and Sealants"](#).
2. Install the carrier cover to the gear carrier. Tighten the bolts to the specified torque. Refer to [FFD-15, "COMPONENTS"](#).
3. Install the front final drive assembly. Refer to [FFD-13, "Removal and Installation"](#).

#### CAUTION:

Remove any old sealant adhering to the mating surfaces. Also remove any moisture, oil, or foreign material adhering to the application and mating surfaces.

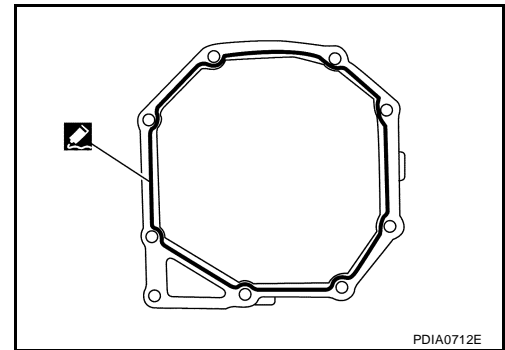

#### CAUTION:

Fill the front final drive assembly with recommended differential gear oil. Refer to [FFD-8, "DIFFERENTIAL GEAR OIL"](#).

# FRONT FINAL DRIVE ASSEMBLY

PFP:38500

## FRONT FINAL DRIVE ASSEMBLY

### Removal and Installation

EDS00468

SEC. 381

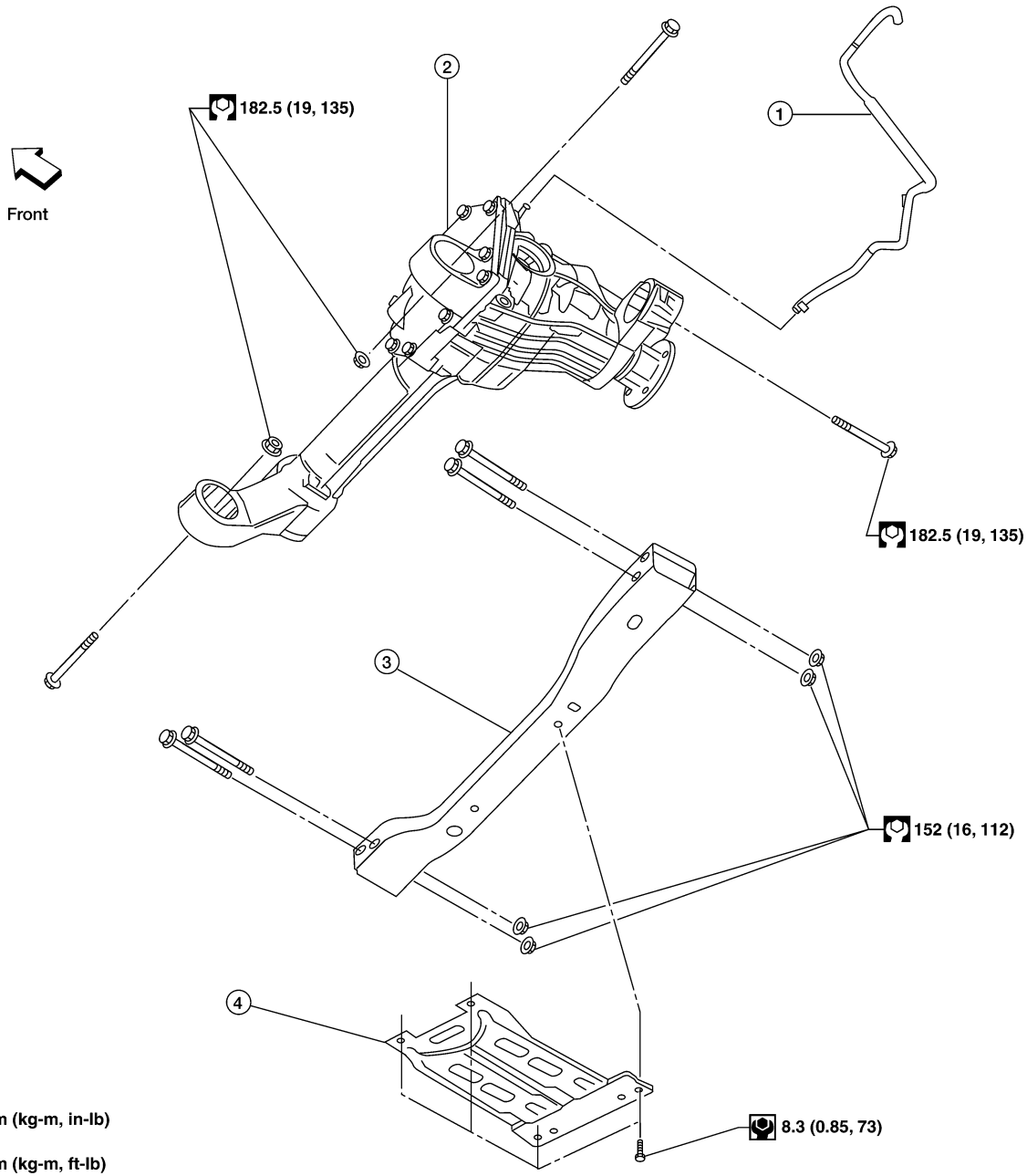

N-m (kg-m, in-lb)

N-m (kg-m, ft-lb)

8.3 (0.85, 73)

182.5 (19, 135)

152 (16, 112)

1. Breather hose
4. Engine under cover

2. Front final drive assembly

3. Front crossmember

LDIA0179E

### REMOVAL

1. Drain the differential gear oil. Refer to [FFD-8, "DIFFERENTIAL GEAR OIL"](#).
2. Remove the drive shafts from the front final drive assembly. Refer to [FAX-7, "Removal and Installation"](#).
3. Remove the front crossmember.
4. Remove the front propeller shaft from the front final drive assembly. Refer to [PR-5, "Removal and Installation"](#).
5. Disconnect the vent hose from the front final drive assembly.
6. Support the front final drive assembly using a suitable jack.

## FRONT FINAL DRIVE ASSEMBLY

7. Remove the front final drive assembly bolts, then remove the front final drive assembly.

**CAUTION:**

Support the front final drive assembly while removing using a suitable jack.

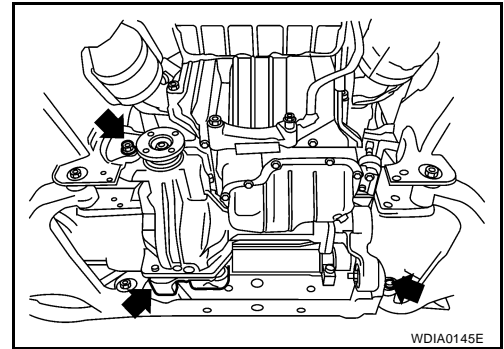

### INSTALLATION

Installation is in the reverse order of removal.

- Install new side oil seals into the front final drive assembly. Refer to [FFD-11, "Removal and Installation"](#) .

**CAUTION:**

- Make sure there are no pinched or restricted areas on the breather hose caused by folding or bending when installing it.
- Fill the front final drive assembly with differential gear oil after installation. Refer to [FFD-8, "DIFFERENTIAL GEAR OIL"](#) .

# FRONT FINAL DRIVE ASSEMBLY

EDS00469

## Disassembly and Assembly COMPONENTS

SEC. 380

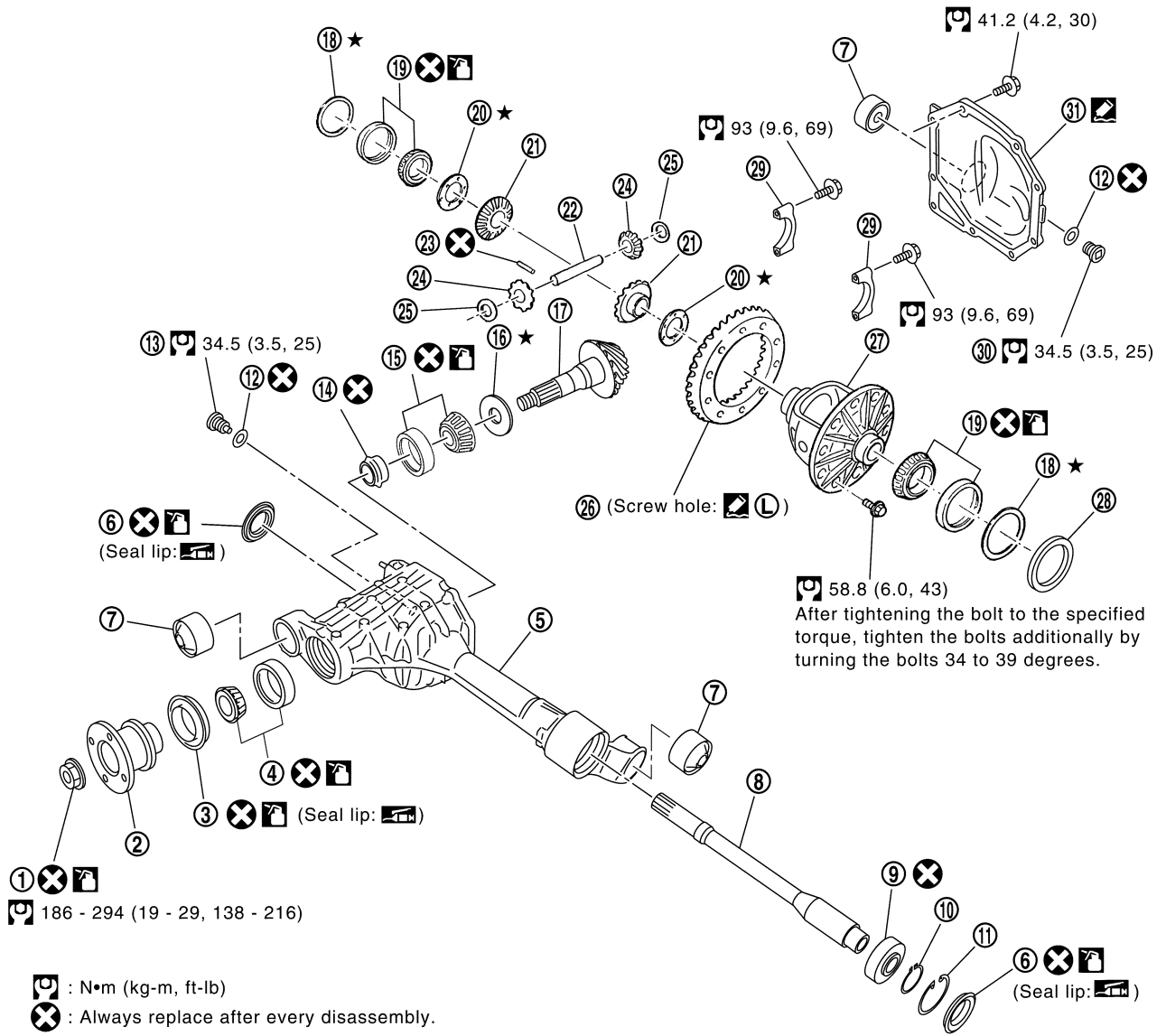

- : N•m (kg-m, ft-lb)
- : Always replace after every disassembly.
- : Select with proper thickness.
- : Apply multi-purpose grease.
- : Apply gear oil.
- : Apply Genuine Silicone RTV or equivalent. Refer to GI section.
- : Apply Genuine High Strength Thread Locking Sealant or equivalent. Refer to GI section.

WDIA0265E

- |  |                             |                                    |
|--|-----------------------------|------------------------------------|
| 1. Drive pinion lock nut                 | 2. Companion flange         | 3. Front oil seal                  |
| 4. Drive pinion front bearing            | 5. Gear carrier             | 6. Side oil seal                   |
| 7. Bushing                               | 8. Differential side shaft  | 9. Differential side shaft bearing |
| 10. Snap ring                            | 11. Snap ring               | 12. Gasket                         |
| 13. Drain plug                           | 14. Collapsible spacer      | 15. Drive pinion rear bearing      |
| 16. Drive pinion height adjusting washer | 17. Drive pinion            | 18. Side bearing adjusting washer  |
| 19. Side bearing                         | 20. Side gear thrust washer | 21. Side gear                      |
| 22. Pinion mate shaft                    | 23. Lock pin                | 24. Pinion mate gear               |
| 25. Pinion mate thrust washer            | 26. Drive gear              | 27. Differential case              |
| 28. Housing spacer                       | 29. Side bearing cap        | 30. Filler plug                    |
| 31. Carrier cover                        |                             |                                    |

# FRONT FINAL DRIVE ASSEMBLY

## ASSEMBLY INSPECTION AND ADJUSTMENT

- Drain the differential gear oil before inspection and adjustment. Refer to [FFD-8, "DIFFERENTIAL GEAR OIL"](#).
- Remove and install the carrier cover as necessary for inspection and adjustment. Refer to [FFD-12, "CARRIER COVER"](#).

### Total Preload Torque

1. Install the differential side shaft if necessary. Refer to [FFD-33, "Differential side shaft"](#).

**CAUTION:**

**The differential side shaft must be installed in order to measure total preload torque.**

2. Rotate the drive pinion back and forth 2 to 3 times to check for unusual noise and rotation malfunction.
3. Rotate the drive pinion at least 20 times to check for smooth operation of the bearings.
4. Measure total preload torque using Tool.

**Tool number : ST3127S000 (J-25765-A)**

**Total preload torque:**

**1.67 - 2.74 N-m (0.17 - 0.27 kg-m, 15 - 24 in-lb)**

**NOTE:**

**Total preload torque = Drive pinion bearing preload torque + Side bearing preload torque**

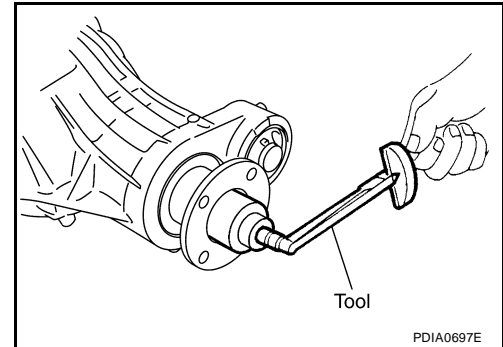

- If the measured value is out of the specification, check and adjust each part. Adjust the drive pinion bearing preload torque first, then adjust the side bearing preload torque.

**If the total preload torque is greater than specification**

**On drive pinion bearings: Replace the collapsible spacer.**

**On side bearings: Use thinner side bearing adjusting washers by the same amount on each side. Refer to [FFD-35, "Side Bearing Adjusting Washer"](#).**

**If the total preload torque is less than specification**

**On drive pinion bearings: Tighten the drive pinion lock nut.**

**On side bearings: Use thicker side bearing adjusting washers by the same amount on each side. Refer to [FFD-35, "Side Bearing Adjusting Washer"](#).**

**CAUTION:**

**Select a side bearing adjusting washer for right and left individually.**

### Drive Gear Runout

1. Fit a dial indicator to the drive gear back face.
2. Rotate the drive gear to measure runout.

**Runout limit: 0.08 mm (0.0031 in) or less**

- If the runout is outside of the limit, check the condition of the drive gear assembly. Foreign material may be caught between the drive gear and differential case, or the differential case or drive gear may be deformed.

**CAUTION:**

**Replace drive gear and drive pinion as a set.**

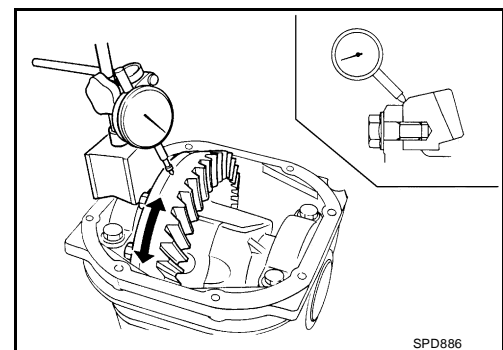



# FRONT FINAL DRIVE ASSEMBLY

## Tooth Contact

1. Apply red lead to the drive gear.

**NOTE:**

Apply red lead to both faces of three to four gears, at four locations evenly spaced on the drive gear.

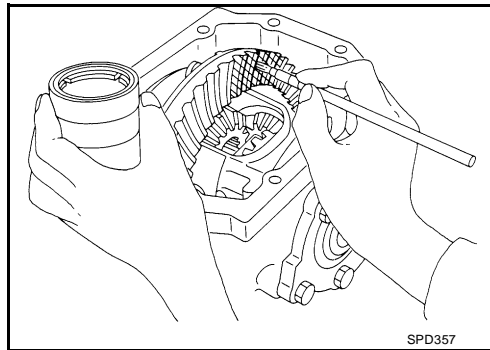

2. Rotate the drive gear back and forth several times. Then check for correct drive pinion to drive gear tooth contact as shown.

**CAUTION:**

**Check tooth contact on drive side and reverse side.**

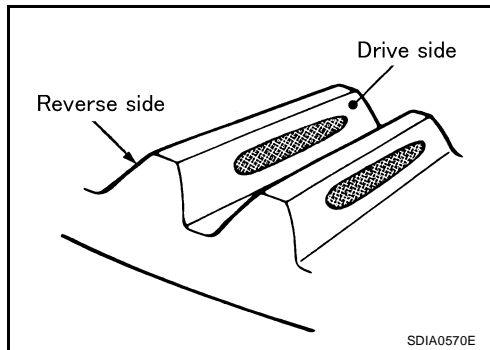

- If the tooth contact is improperly adjusted, adjust the drive pinion height (dimension X).

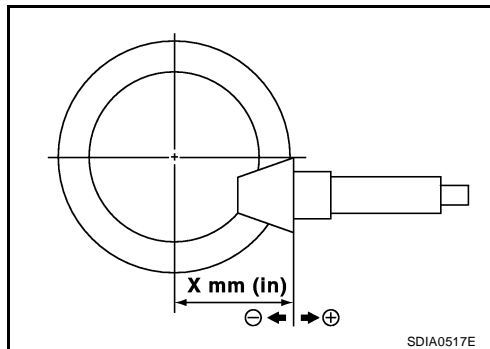

- If the tooth contact is near the face (face contact), or near the heel (heel contact), use a thicker drive pinion height adjusting washer to move drive pinion closer to the drive gear. Refer to [FFD-35, "Drive Pinion Height Adjusting Washer"](#).

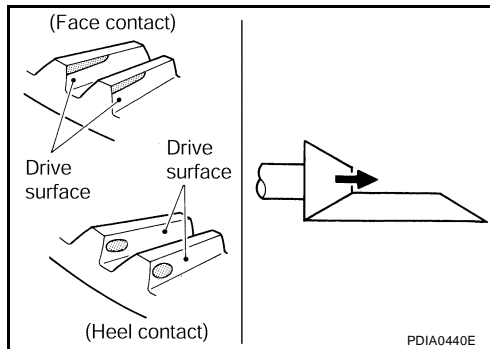

A  
B  
C  
FFD  
E  
F  
G  
H  
I  
J  
K  
L  
M

# FRONT FINAL DRIVE ASSEMBLY

- If the tooth contact is near the flank (flank contact), or near the toe (toe contact), use a thinner drive pinion height adjusting washer to move the drive pinion farther from the drive gear. Refer to [FFD-35, "Drive Pinion Height Adjusting Washer"](#).

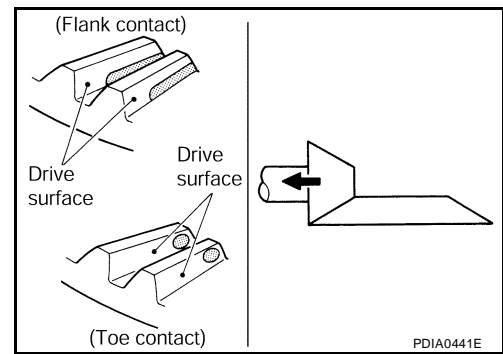

## Backlash

1. Fit a dial indicator to the drive gear face to measure the backlash.

**Backlash:** 0.10 - 0.15 mm (0.0039 - 0.0059 in)

- If the backlash is outside of the specification, change the thickness of the side bearing adjusting washers.

**If the backlash is greater than specification:**

**Make side bearing adjusting washer thicker on drive gear back side, and side bearing adjusting washer thinner on drive gear tooth side by the same amount. Refer to [FFD-35, "Side Bearing Adjusting Washer"](#).**

**If the backlash is less than specification:**

**Make side bearing adjusting washer thinner on drive gear back side, and side bearing adjusting washer thicker on drive gear tooth side by the same amount. Refer to [FFD-35, "Side Bearing Adjusting Washer"](#).**

### CAUTION:

**Do not change the total thickness of side bearing adjusting washers as it will change the side bearing preload torque.**

## Companion Flange Runout

1. Rotate companion flange and check for runout on the companion flange face (inner side of the bolt holes) and companion flange inner side (socket diameter) using suitable tool.

**Runout limit:** 0.1 mm (0.004 in) or less

2. If the runout is outside the runout limit, follow the procedure below to adjust.
  - a. Rotate the companion flange on the drive pinion by 90°, 180° and 270° while checking for the position where the runout is minimum.
  - b. If the runout is still outside of the runout limit after the companion flange has been rotated on the drive pinion, possible cause could be an assembly malfunction of drive pinion and drive pinion bearing or a malfunctioning drive pinion bearing.
  - c. If the runout is still outside of the runout limit after repair of the assembly of drive pinion and drive pinion bearing or drive pinion bearing, replace the companion flange.

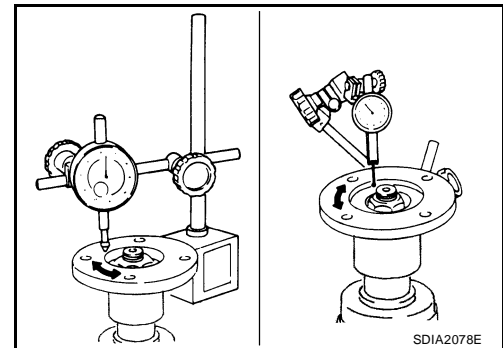

## DISASSEMBLY

### Differential side shaft

1. Drain the differential gear oil if necessary.

# FRONT FINAL DRIVE ASSEMBLY

2. Remove the carrier cover bolts and separate the carrier cover from the gear carrier using Tool.

**Tool number** : KV10111100 (J-37228)

**CAUTION:**

- Do not damage the mating surface.
- Do not insert flat-bladed screwdriver, this will damage the mating surface.

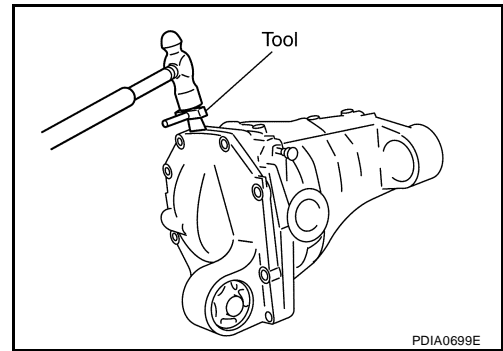

3. Remove side oil seal.

**CAUTION:**

- Do not damage gear carrier.**

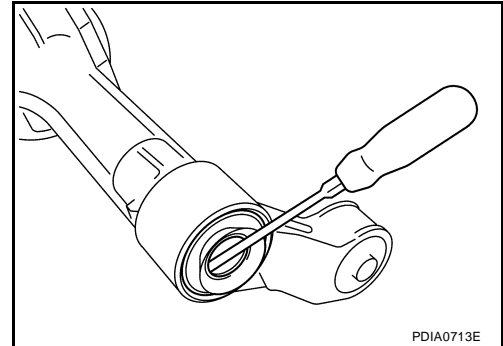

4. Remove snap ring (hole side) using suitable tool.

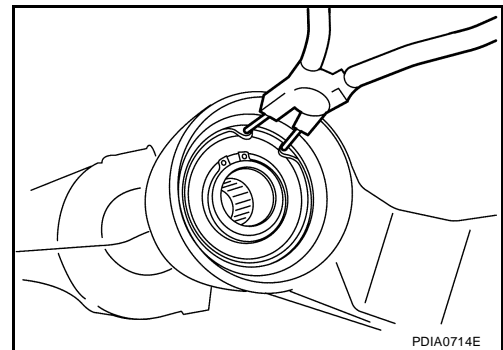

5. Remove differential side shaft assembly out of gear carrier using suitable tool.

**NOTE:**

Tap on differential side shaft assembly from side gear side.

6. Remove snap ring (differential side shaft side).

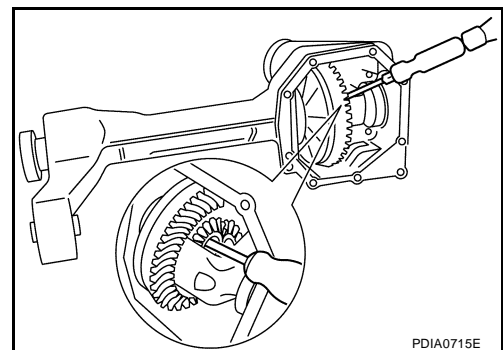

7. Press differential side shaft out of differential side shaft bearing.

**CAUTION:**

**Do not drop differential side shaft.**

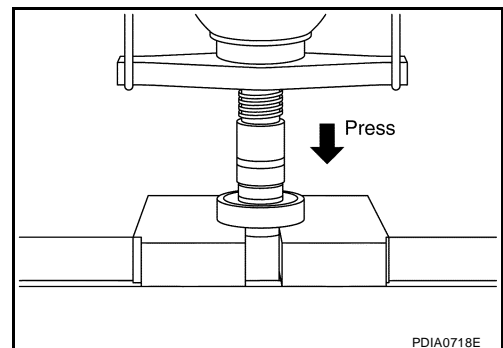

A  
B  
C  
FFD

E  
F  
G  
H  
I  
J  
K  
L  
M

# FRONT FINAL DRIVE ASSEMBLY

## Differential Assembly

1. Remove differential side shaft assembly. Refer to [FFD-18, "Differential side shaft"](#).
2. Remove side seal from gear carrier using suitable tool.
3. For proper reinstallation, paint matching marks on one side of the side bearing cap and gear carrier.

### CAUTION:

- For matching marks, use paint. Do not damage side bearing cap or gear carrier.
- Side bearing caps are line-board during manufacture. The matching marks are used to reinstall them in their original positions.

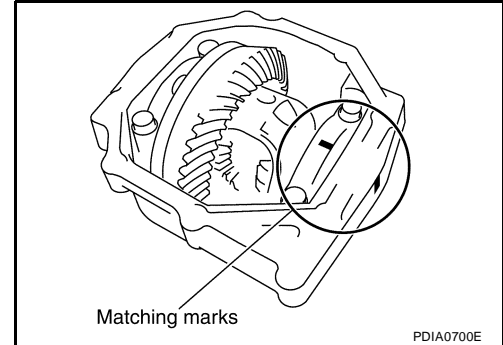

4. Remove the side bearing caps.

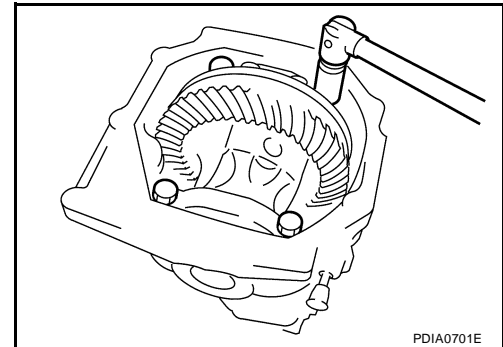

5. Lift the differential case assembly out of the gear carrier.

### CAUTION:

- Keep side bearing outer races together with side bearing inner races. Do not mix them up.
- Keep side bearing adjusting washers together with side bearings.

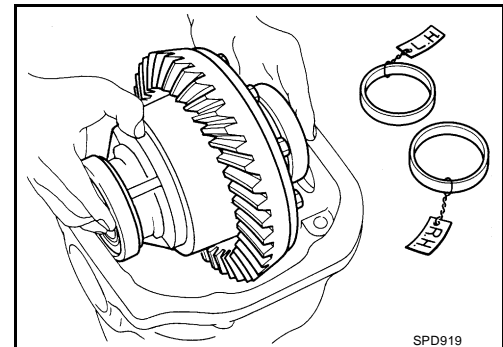

6. Remove housing spacer.
7. Remove side bearing inner race using Tools as shown.

**Tool number**    **A: ST33051001 (J-22888-20)**  
                          **B: ST33061000 (J-8107-2)**

### CAUTION:

- Do not remove side bearing inner race unless it is being replaced.
- Place copper plates between the vise and the side bearing inner race and drive gear to prevent damage.

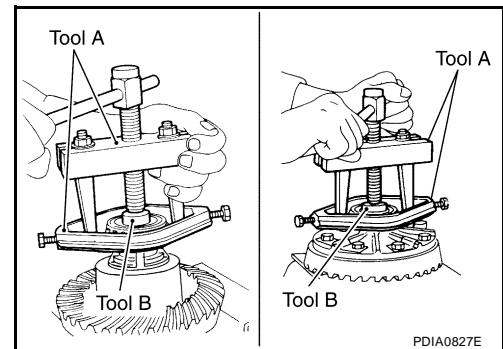

# FRONT FINAL DRIVE ASSEMBLY

- Keep side bearing outer races together with side bearing inner races. Do not mix them up.

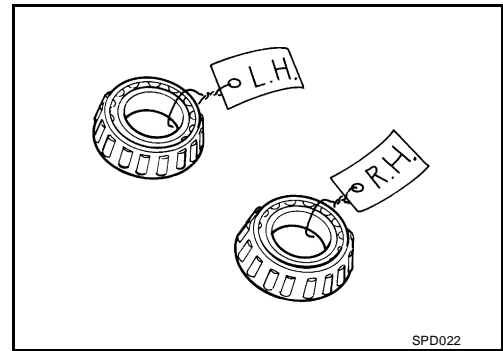

8. For proper reinstallation, paint matching marks on the differential case and drive gear.

**CAUTION:**

**Use paint for matching marks. Do not damage differential case or drive gear.**

9. Remove the drive gear bolts.

10. Tap the drive gear off the differential case using suitable tool.

**CAUTION:**

**Tap evenly all around to keep drive gear from bending.**

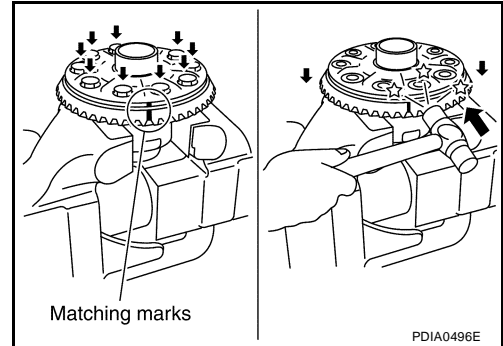

11. Remove the lock pin of the pinion mate shaft from the drive gear side using suitable tool.

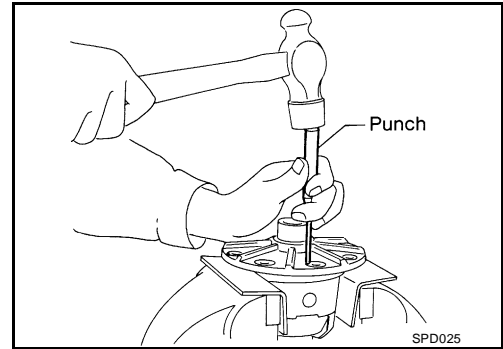

12. Remove the pinion mate shaft.

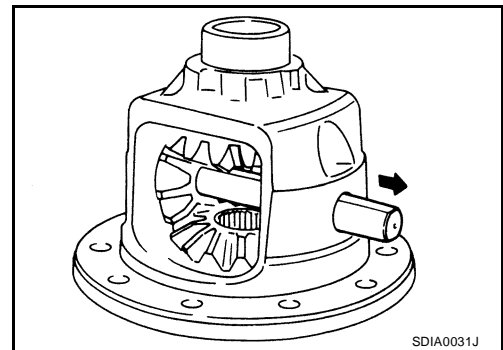

13. Turn the pinion mate gear, then remove the pinion mate gear, pinion mate thrust washer, side gear and side gear thrust washer from the differential case.

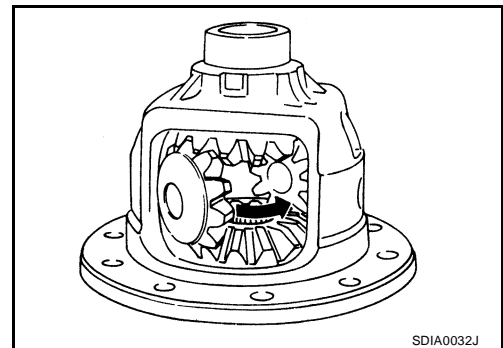

A  
B  
C  
FFD

E  
F  
G

H  
I  
J

K  
L  
M

# FRONT FINAL DRIVE ASSEMBLY

## Drive Pinion Assembly

1. Remove the differential assembly. Refer to [FFD-20, "Differential Assembly"](#).
2. Remove the drive pinion lock nut using Tool.

**Tool number : KV38108300 (J-44195)**

3. Put matching marks on the companion flange and drive pinion using paint.

**CAUTION:**

**Use paint to make the matching marks. Do not damage the companion flange or drive pinion.**

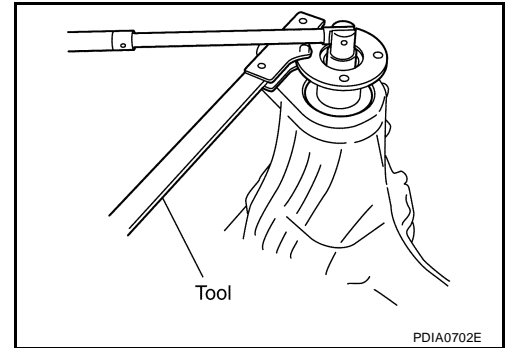

4. Remove the companion flange using suitable tool.

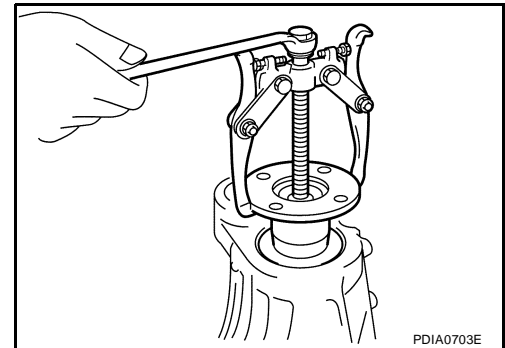

5. Press the drive pinion assembly (with rear inner bearing race and collapsible spacer) out of the gear carrier.

**CAUTION:**

**Do not drop drive pinion assembly.**

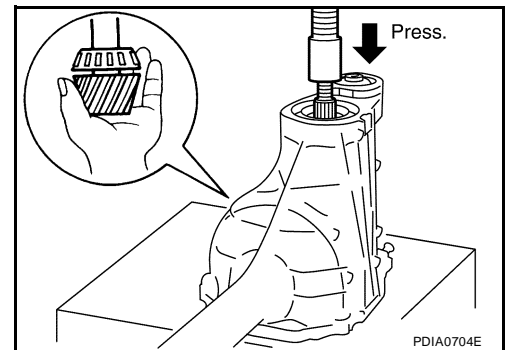

6. Remove the drive pinion rear bearing inner race and drive pinion height adjusting washer using Tool.

**Tool number : ST30031000 (J-22912-01)**

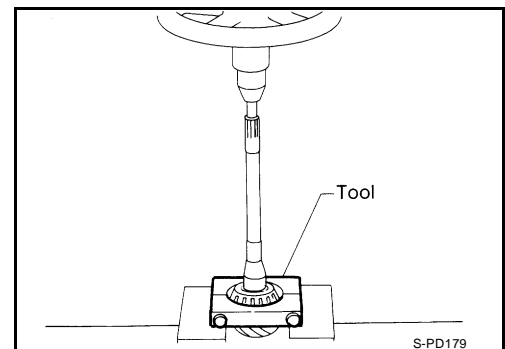

# FRONT FINAL DRIVE ASSEMBLY

7. Remove the front oil seal using suitable tool.

**CAUTION:**

**Do not damage gear carrier.**

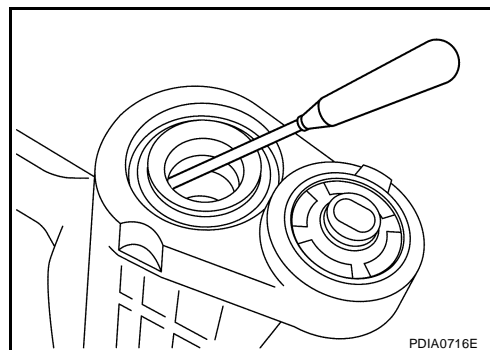

8. Remove the drive pinion front bearing inner race.  
9. Remove the drive pinion front and rear bearing outer races by tapping them uniformly using suitable tool.

**CAUTION:**

**Do not damage gear carrier.**

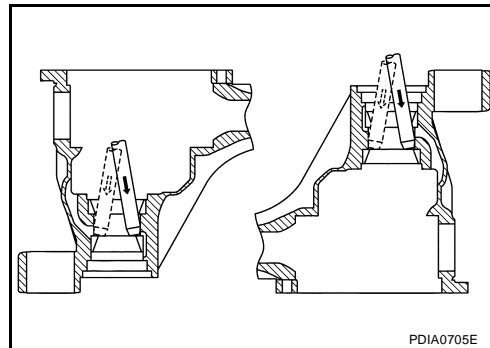

## INSPECTION AFTER DISASSEMBLY

Clean the disassembled parts. Then inspect the parts for wear or damage. If wear or damage are found, follow the measures below.

### Drive Pinion and Drive Gear

- If the drive pinion and drive gear teeth do not mesh or line-up correctly, determine the cause and adjust, repair, or replace as necessary.
- If the drive pinion or drive gear are worn, cracked, damaged, pitted or chipped (by friction) noticeably, replace with new drive pinion and drive gear.
- Drive pinion and drive gear are supplied in matched sets only. Matching numbers on both drive pinion and drive gear are etched for verification. If a new drive pinion and drive gear set are being used, verify the numbers of each drive pinion and drive gear before proceeding with assembly.

### Bearing

- If bearings are chipped (by friction), pitted, worn, rusted, scratched, or unusual noise is coming from bearing, replace with new bearing assembly (as a new set).
- Bearing must be replaced with a new one whenever disassembled.

### Side Gear and Pinion Mate Gear

- If any cracks or damage are found on the surface of the teeth, replace with new one.
- If any worn or chipped marks are found on the side of the side gear and pinion mate gear which contact the thrust washer, replace with new one.
- Replace both side gear and pinion mate gear as a set when replacing side gear or pinion mate gear.

### Side Gear Thrust Washer and Pinion Mate Thrust Washer

- If any chips (by friction), damage, or unusual wear are found, replace with new one.

### Gear Carrier

- If any wear or cracks are found on the contact sides of gear carrier, replace with new one.

### Companion Flange

- If any chips (about 0.1mm, 0.004 in) or other damage on the companion flange surface which contacts the front oil seal lips are found, replace with new one.

A  
B  
C  
FFD  
E  
F  
G  
H  
I  
J  
K  
L  
M

# FRONT FINAL DRIVE ASSEMBLY

## ADJUSTING AND SELECTING WASHERS

### Side Gear Back Clearance

- Assemble the differential parts if they are disassembled. Refer to [FFD-30, "Differential Assembly"](#).
- Place the differential case straight up so that the side gear to be measured is upward.

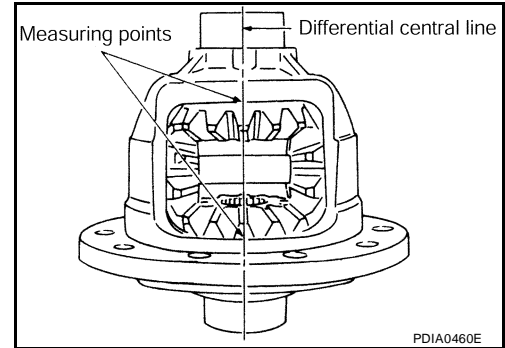

- Using feeler gauges, measure the clearance between the side gear back and differential case at three different points, while rotating the side gear. Average the three readings to calculate the clearance. (Measure the clearance of the other side as well.)

**Side gear back clearance: 0.1 mm (0.004 in) or less.**

- If the side gear back clearance is outside of the specification, use a thicker or thinner side gear thrust washer to adjust. Refer to [FFD-35, "Side Gear Thrust Washer"](#).

**If the side gear back clearance is greater than specification:**

**Use a thicker side gear thrust washer.**

**If the side gear back clearance is less than specification:**

**Use a thinner side gear thrust washer.**

#### CAUTION:

- Insert feeler gauges with the same thickness on both sides to prevent side gear from tilting.
- Each gear should rotate smoothly without excessive resistance during differential motion.
- Select a side gear thrust washer for right and left individually.

#### NOTE:

Side gear back clearance is clearance between side gear and differential case for adjusting side gear backlash.

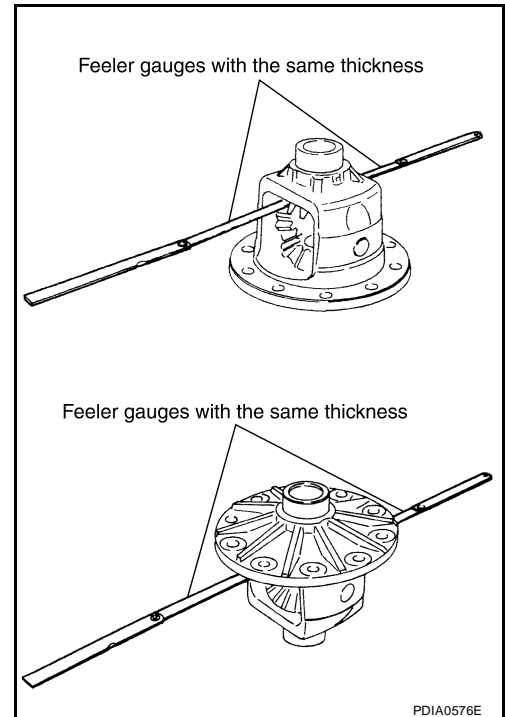

### Drive Pinion Height

- Make sure all parts are clean and that the bearings are well lubricated.
- Assemble the drive pinion bearings onto the Tool.

**Tool number : — (J-34309)**

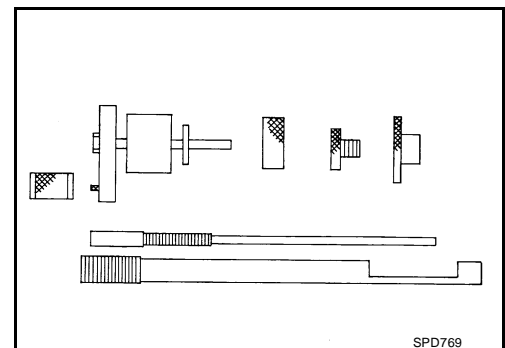



## FRONT FINAL DRIVE ASSEMBLY

- **Drive pinion front bearing;** make sure the J-34309-3 drive pinion front bearing seat is secured tightly against the J-34309-2 gauge anvil. Then turn the J-34309-7 drive pinion front bearing pilot to secure the drive pinion front bearing in its proper position.
- **Drive pinion rear bearing;** the J-34309-8 drive pinion rear bearing pilot is used to center the drive pinion rear bearing only. The J-34309-4 drive pinion rear bearing locking seat is used to lock the drive pinion rear bearing to the assembly.
- **Installation of J-34309-9 and J-34309-16;** place a suitable 2.5 mm (0.098 in) thick plain washer between J-34309-9 and J-34309-16. Both surfaces of J-34309-9 and J-34309-16 must be parallel with a clearance of 2.5 mm (0.098 in).

3. Install the drive pinion rear bearing inner race into the gear carrier. Then insert the drive pinion height adjusting washer selector tool, J-34309-1, gauge screw assembly.

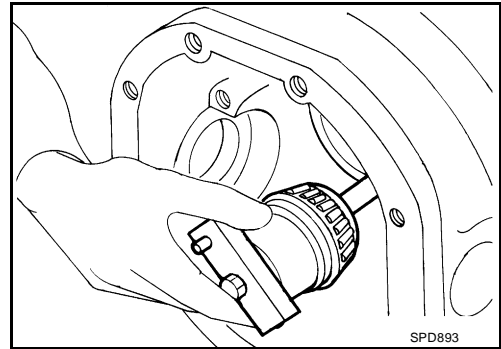
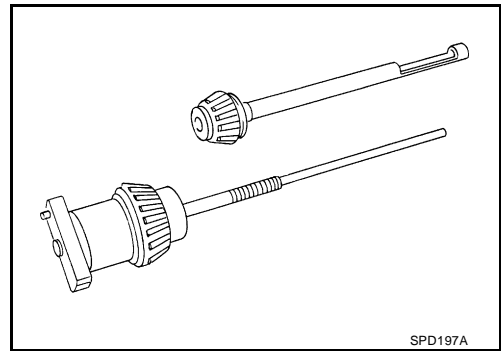

4. Assemble the drive pinion front bearing inner race and the J-34309-2 gauge anvil. Assemble them together with the J-34309-1 gauge screw in the gear carrier. Make sure that the drive pinion height gauge plate, J-34309-16, will turn a full 360°. Tighten the two sections together by hand.

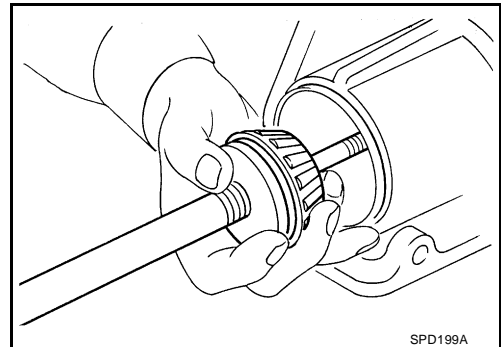

5. Turn the assembly several times to seat the drive pinion bearings.

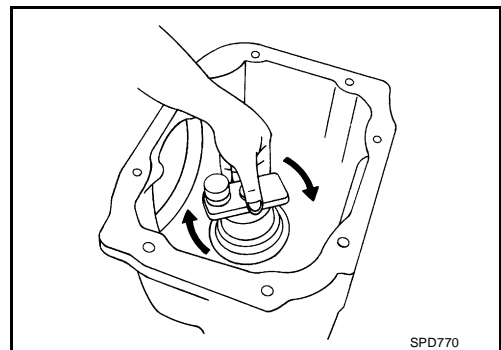

A  
B  
C  
FFD

E  
F  
G  
H  
I  
J  
K  
L  
M

## FRONT FINAL DRIVE ASSEMBLY

6. Measure the turning torque at the end of the J-34309-2 gauge anvil using Tool.

**Tool number** : **ST3127S000 (J-25765- A)**

**Turning torque specification:**

**1.0 - 1.6 N·m (0.11 - 0.16 kg·m, 9 - 14 in·lb)**

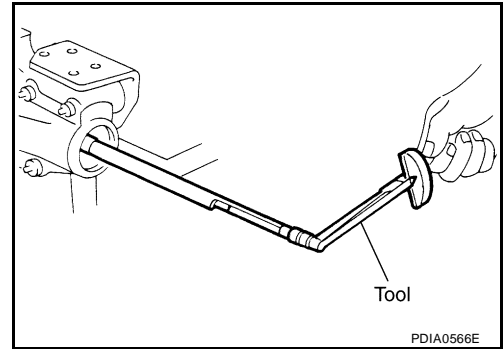

7. Place the J-34309-10 "R180A" drive pinion height adapter onto the gauge plate and tighten it by hand.

**CAUTION:**

**Make sure all machined surfaces are clean.**

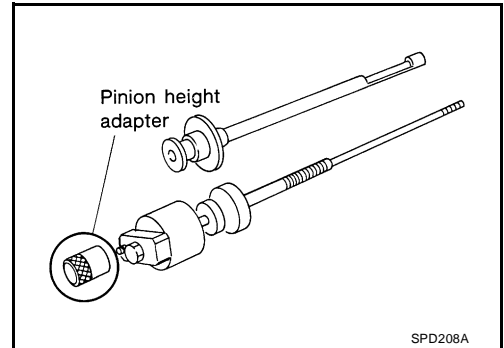

8. Position the side bearing discs, Tool, and arbor firmly into the side bearing bores. Install the side bearing caps and tighten the side bearing cap bolts to the specified torque. Refer to [FFD-15, "COMPONENTS"](#).

**Tool number** : — **(J-25269-18)**

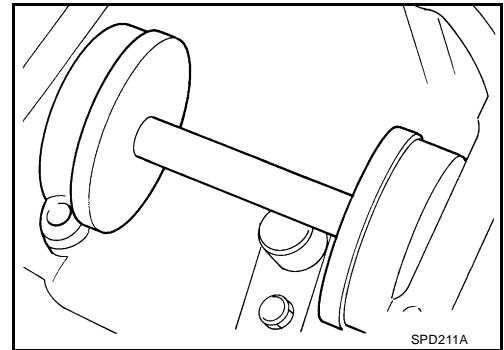

9. Select the correct standard drive pinion height adjusting washer thickness. Select by using a standard gauge of 3 mm (0.12 in) and your J-34309-101 feeler gauge. Measure the distance between the J-34309-10 drive pinion height adapter, including the standard gauge and the arbor.

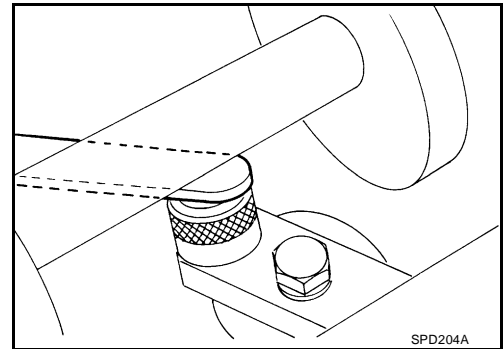

10. Write down the exact measurement (the value of feeler gauge).

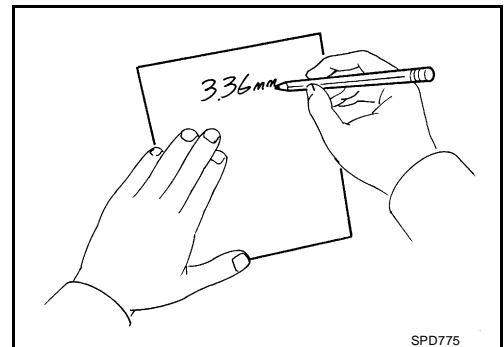

# FRONT FINAL DRIVE ASSEMBLY

11. Correct the drive pinion height adjusting washer size by referring to the drive pinion “head number”.

**There are two numbers painted on the drive pinion. The first one refers to the drive pinion and drive gear as a matched set. This number should be the same as the number on the drive gear. The second number is the drive pinion “head number”. It refers to the ideal drive pinion height from standard for quietest operation. Use the following chart to determine the correct drive pinion height adjusting washer.**

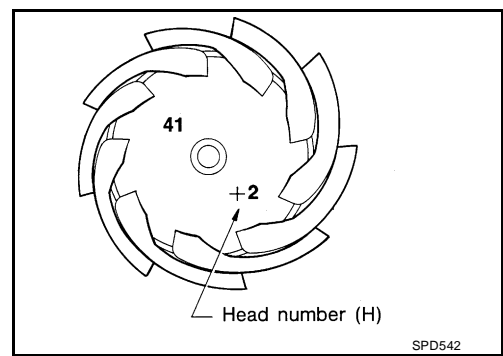

| Head number | Add or remove from the standard drive pinion height adjusting washer thickness measurement |
|-------------|--|
| -6          | Add 0.06 mm (0.0024 in)  |
| -5          | Add 0.05 mm (0.0020 in)  |
| -4          | Add 0.04 mm (0.0016 in)  |
| -3          | Add 0.03 mm (0.0012 in)  |
| -2          | Add 0.02 mm (0.0008 in)  |
| -1          | Add 0.01 mm (0.0004 in)  |
| 0           | Use the selected washer thickness  |
| +1          | Subtract 0.01 mm (0.0004 in)   |
| +2          | Subtract 0.02 mm (0.0008 in)   |
| +3          | Subtract 0.03 mm (0.0012 in)   |
| +4          | Subtract 0.04 mm (0.0016 in)   |
| +5          | Subtract 0.05 mm (0.0020 in)   |
| +6          | Subtract 0.06 mm (0.0024 in)   |

12. Select the correct drive pinion height adjusting washer. Refer to [FFD-35, "Drive Pinion Height Adjusting Washer"](#).

13. Remove the Tool from the gear carrier and disassemble to retrieve the drive pinion bearings.

**Tool number : — (J-34309)**

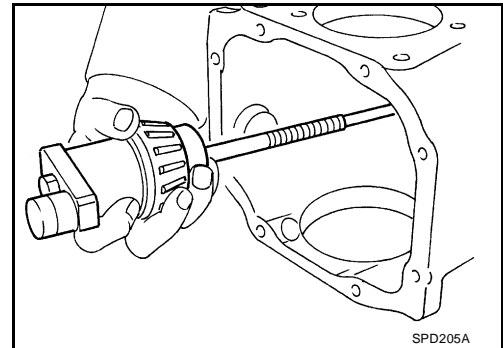

A  
B  
C  
FFD  
E  
F  
G  
H  
I  
J  
K  
L  
M

# FRONT FINAL DRIVE ASSEMBLY

## ASSEMBLY

### Drive Pinion Assembly

1. Install drive pinion rear bearing outer race and drive pinion front bearing outer race using Tools.

**Tool number**     **A: ST30611000 (J-25742-1)**  
                          **B: ST30613000 (J-25742-3)**  
                          **C: KV38100200 (J-26233)**

**CAUTION:**

- First tap the drive pinion bearing outer race until it becomes flush with the gear carrier.
- Do not reuse drive pinion front and rear bearing outer race.

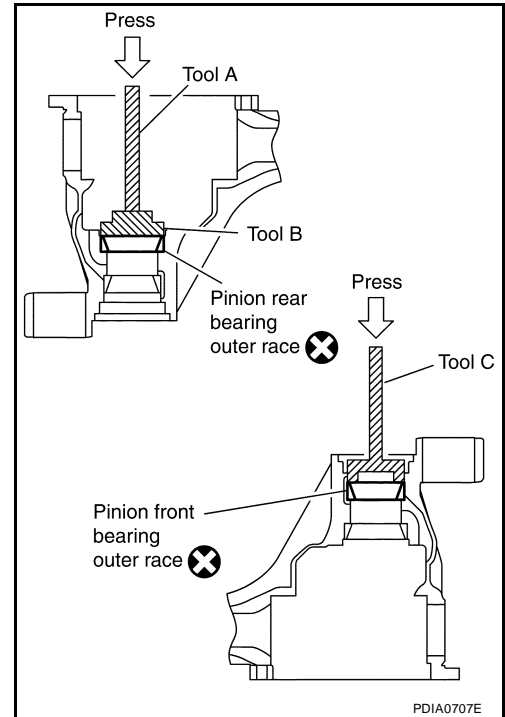

2. Select drive pinion height adjusting washer. Refer to [FFD-24, "Drive Pinion Height"](#).
3. Install the selected drive pinion height adjusting washer to the drive pinion. Press the drive pinion rear bearing inner race to it using Tool.

**Tool number**     **: ST30901000 (J-26010-01)**

**CAUTION:**

- Install the drive pinion height adjusting washer in the proper direction as shown.
- Do not reuse drive pinion rear bearing inner race.

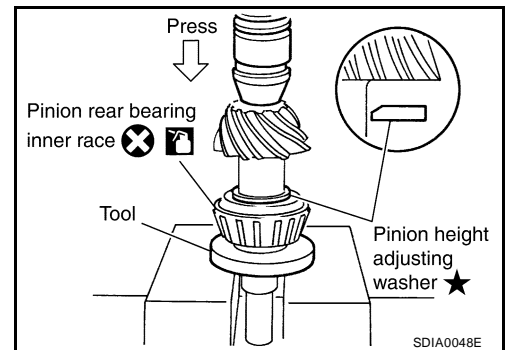

4. Install the collapsible spacer to the drive pinion.

**CAUTION:**

**Do not reuse collapsible spacer.**

5. Apply differential gear oil to the drive pinion rear bearing, and install the drive pinion assembly to the gear carrier.
6. Apply differential gear oil to the drive pinion front bearing, and install the drive pinion front bearing inner race to the drive pinion assembly.

**CAUTION:**

**Do not reuse drive pinion front bearing inner race.**

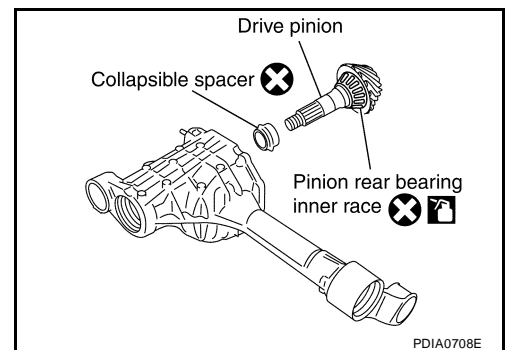

# FRONT FINAL DRIVE ASSEMBLY

7. Press the drive pinion front bearing inner race to the drive pinion as far as drive pinion lock nut can be tightened using Tool.

**Tool number : ST33200000 (J-26082)**

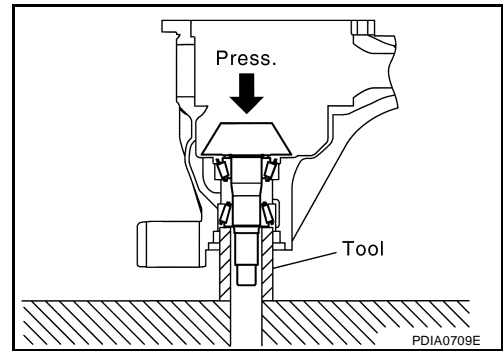

8. Apply multi-purpose grease to the lips and differential gear oil to the circumference of the new front oil seal. Then drive the new front oil seal in evenly until it becomes flush with the gear carrier using Tools.

**Tool number A: ST30720000 (J-25405)**

**B: ST27863000 ( — )**

**CAUTION:**

- Do not reuse front oil seal.
- Do not incline the new front oil seal when installing.
- Apply multi-purpose grease to the lips and differential gear oil to the circumference of the new front oil seal.

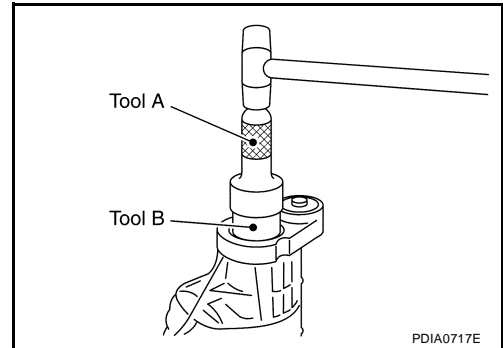

9. Install the companion flange to the drive pinion while aligning the matching marks.

10. Apply anti-corrosive oil to the threads of the drive pinion and the seating surface of the new drive pinion lock nut. Then adjust the drive pinion lock nut tightening torque using Tool A, and check the drive pinion bearing preload torque using Tool B.

**Tool number A: KV38108300 (J-44195)**

**B: ST3127S000 (J-25765-A)**

**Drive pinion bearing preload torque:**

**1.08 - 1.66 N·m (0.11 - 0.16 kg·m, 10 - 14 in·lb)**

**CAUTION:**

- Do not reuse drive pinion lock nut.
- Apply anti-corrosive oil to the threads of the drive pinion and the seating surface of the new drive pinion lock nut.
- Adjust the drive pinion lock nut tightening torque to the lower limit first. Do not exceed the drive pinion lock nut specified torque. Refer to [FFD-15, "COMPONENTS"](#).
- If the drive pinion bearing preload torque exceeds the specified value, replace collapsible spacer and tighten it again to adjust. Do not loosen drive pinion lock nut to adjust the drive pinion bearing preload torque.
- After adjustment, rotate drive pinion back and forth 2 to 3 times to check for unusual noise, rotation malfunction, and other malfunctions.

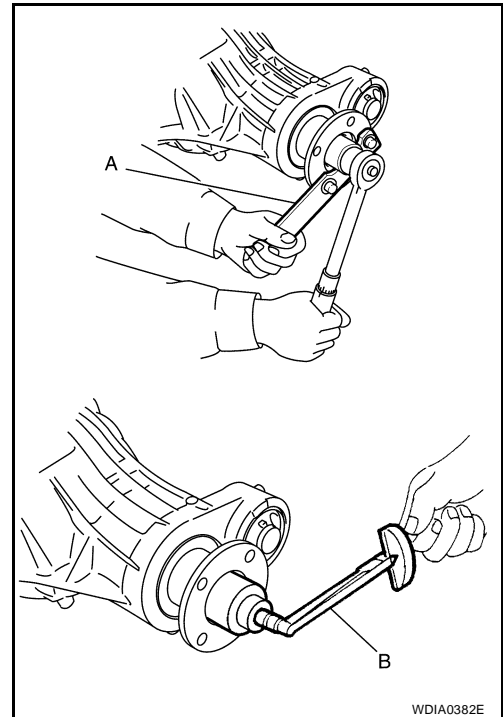

11. Check companion flange runout. Refer to [FFD-18, "Companion Flange Runout"](#).

12. Install the differential case assembly. Refer to [FFD-30, "Differential Assembly"](#).

# FRONT FINAL DRIVE ASSEMBLY

## Differential Assembly

1. Install side gear thrust washers with the same thickness as the ones installed prior to disassembly, or reinstall the old ones on the side gears.

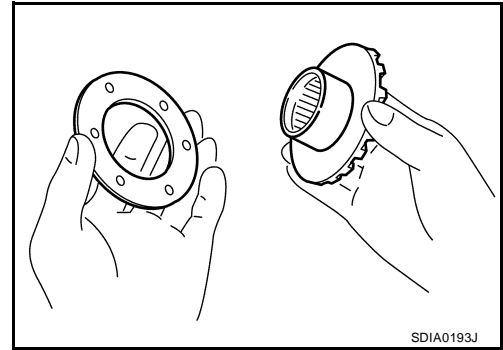

2. Install the side gears and side gear thrust washers into the differential case.
3. Install the pinion mate thrust washers to the two pinion mate gears. Then install the pinion mate gears with the pinion mate thrust washers by aligning them in diagonally opposite positions and rotating them into the differential case.

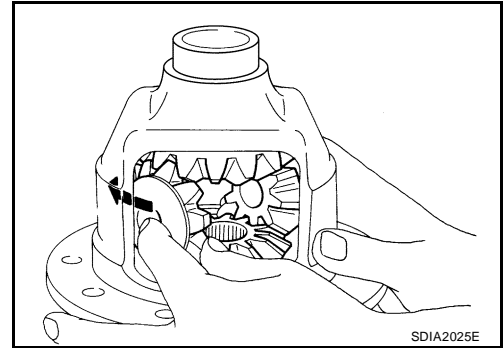

4. Install the pinion mate shaft and align the lock pin hole on the pinion mate shaft with the lock pin hole on the differential case.
5. Measure the side gear end play. If necessary, select the appropriate side gear thrust washers. Refer to [FFD-24, "Side Gear Back Clearance"](#).

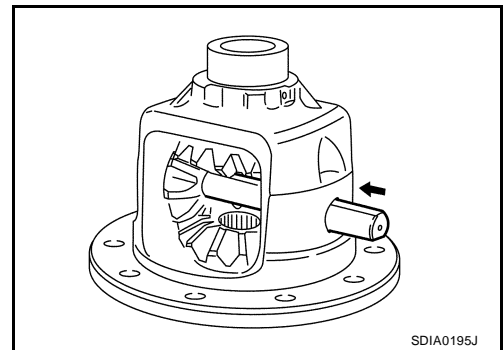

6. Drive a new lock pin into the pinion mate shaft until it is flush with the differential case using suitable tool.

**CAUTION:**  
Do not reuse lock pin.

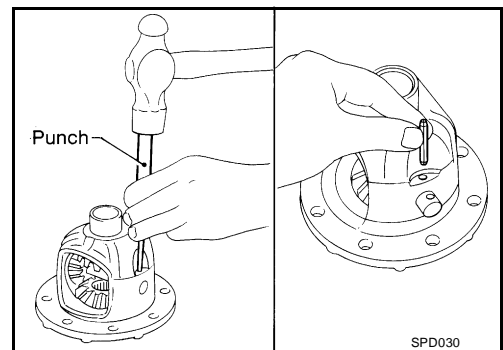

# FRONT FINAL DRIVE ASSEMBLY

7. Align the matching mark of the differential case with the mark of the drive gear, then place the drive gear onto the differential case.

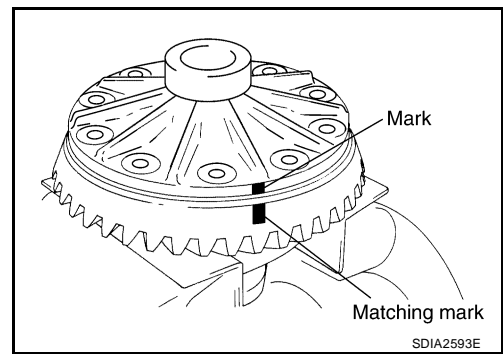

8. Apply thread locking sealant into the threaded holes of the drive gear and install the new drive gear bolts.

- Use Genuine High Strength Thread Locking Sealant or equivalent. Refer to [GI-47, "Recommended Chemical Products and Sealants"](#).

**CAUTION:**

Make sure the drive gear back and threaded holes are clean.

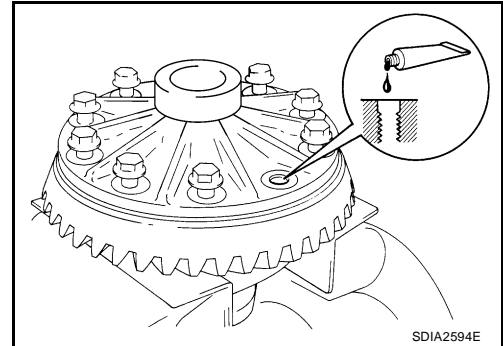

9. Tighten the new drive gear bolts to the specified torque. Refer to [FFD-15, "COMPONENTS"](#). After tightening the new drive gear bolts to the specified torque, tighten an additional 34° to 39° using Tool.

Tool number : KV10112100-A (BT-8653-A)

**CAUTION:**

- Always use Tool. Avoid tightening based on visual check alone.
- Tighten new drive gear bolts in a crisscross pattern.

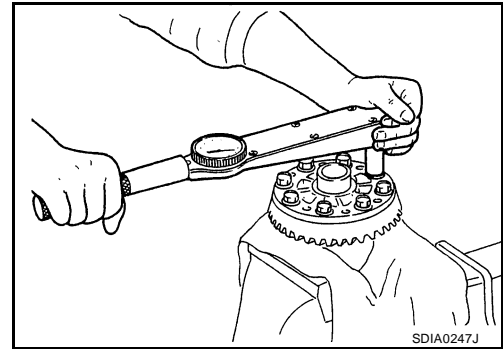

10. Press the new side bearing inner races to the differential case using Tools.

Tool number A: ST33230000 (J-35867)

B: ST33061000 (J-8107-2)

**CAUTION:**

Do not reuse side bearing inner races.

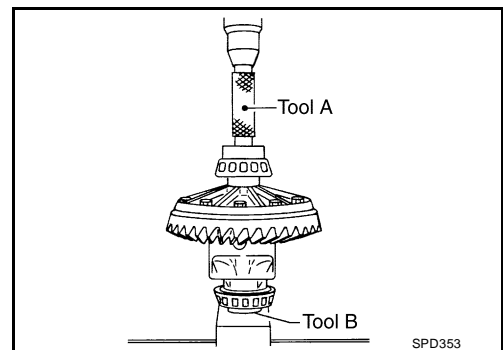

11. Install housing spacer into gear carrier.

A  
B  
C  
FFD  
E  
F  
G  
H  
I  
J  
K  
L  
M

## FRONT FINAL DRIVE ASSEMBLY

12. Apply differential gear oil to the side bearings, and install the differential case assembly with the side bearing outer races into the gear carrier.

**CAUTION:**

**Do not reuse side bearing outer race when replacing side bearing inner race (replace as a set).**

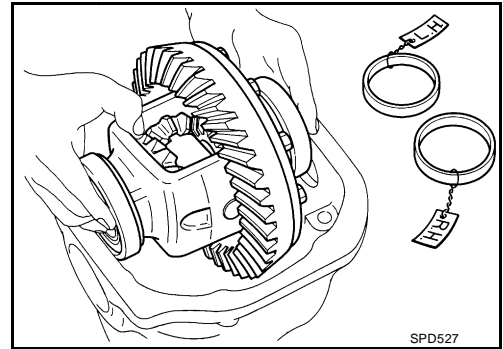

13. Insert left and right original side bearing adjusting washers in place between side bearings and gear carrier using Tool.

**Tool number : KV38100600 (J-25267)**

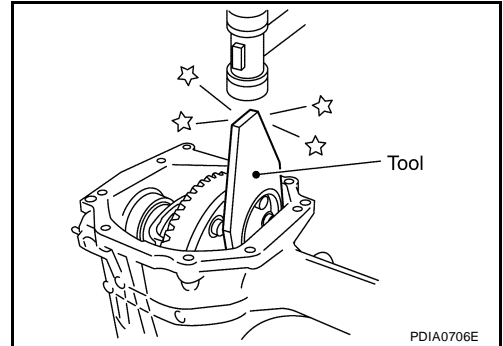

14. Install the side bearing caps with the matching marks aligned and tighten the side bearing cap bolts to the specified torque. Refer to [FFD-15, "COMPONENTS"](#).

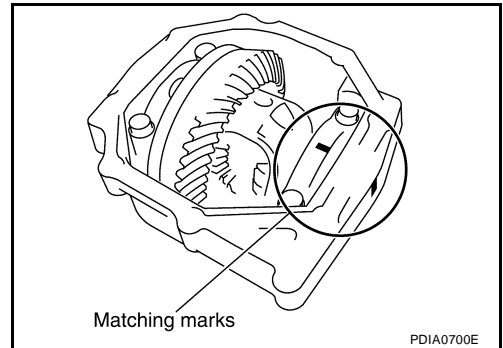

15. Apply multi-purpose grease to the lips and differential gear oil to the circumference of the new side oil seal. Then drive the new side oil seal in evenly until it becomes flush with the gear carrier using Tools.

**Tool number A: ST30720000 (J-25405)**

**B: ST27863000 ( — )**

**CAUTION:**

- Do not reuse side oil seal.
- Do not incline the new side oil seal when installing.
- Apply multi-purpose grease to the lips and differential gear oil to the circumference of the new side oil seal.

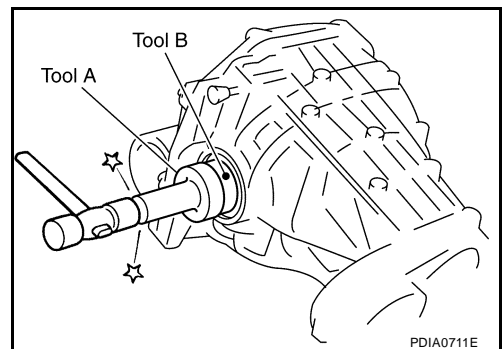

16. Check and adjust tooth contact, backlash, drive gear runout and total preload torque. Refer to [FFD-17, "Tooth Contact"](#), [FFD-18, "Backlash"](#), [FFD-16, "Drive Gear Runout"](#) and [FFD-16, "Total Preload Torque"](#).

Recheck above items.



# FRONT FINAL DRIVE ASSEMBLY

17. Apply a 3 mm (0.12 in) bead of sealant to the mating surface of the carrier cover as shown.

- Use Genuine Silicone RTV or equivalent. Refer to [GI-47, "Recommended Chemical Products and Sealants"](#).

**CAUTION:**

**Remove any old sealant adhering to the mating surfaces. Also remove any moisture, oil, or foreign material adhering to the application and mating surfaces.**

18. Install the carrier cover to the gear carrier. Tighten the bolts to the specified torque. Refer to [FFD-15, "COMPONENTS"](#).

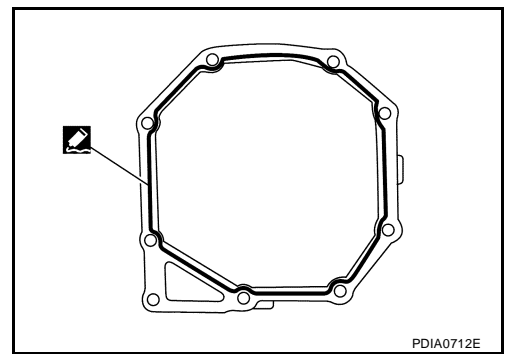

## Differential side shaft

1. Press differential side shaft bearing to differential side shaft.

**CAUTION:**

**Do not reuse differential side shaft bearing.**

2. Install snap ring (differential side shaft side).
3. Install differential side shaft assembly into gear carrier.
4. Install snap ring (hole side).

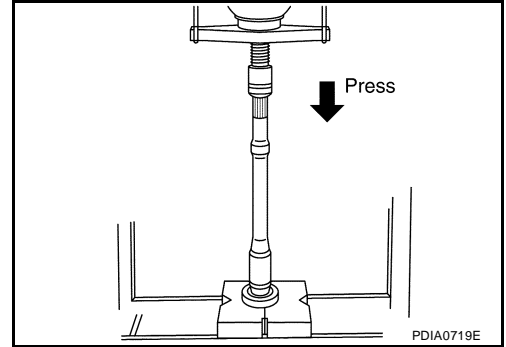

5. Apply multi-purpose grease to the lips and differential gear oil to the circumference of the new side oil seal. Then drive the new side oil seal in evenly until it becomes flush with the gear carrier using Tools.

**Tool number**     **A: ST30720000 (J-25405)**  
                             **B: ST27863000 ( — )**

**CAUTION:**

- Do not reuse side oil seal.
- Do not incline the new side oil seal when installing.
- Apply multi-purpose grease to the lips and differential gear oil to the circumference of the new side oil seal.

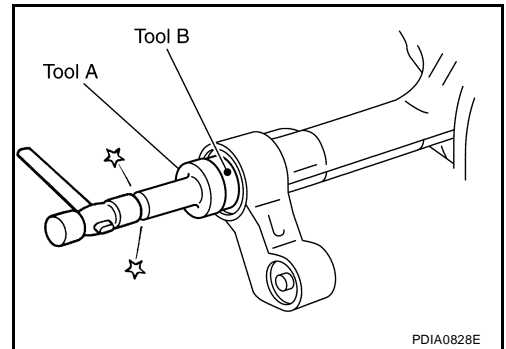

A  
B  
C  
FFD  
E  
F  
G  
H  
I  
J  
K  
L  
M

# SERVICE DATA AND SPECIFICATIONS (SDS)

## SERVICE DATA AND SPECIFICATIONS (SDS)

PF0:00030

### General Specifications

EDS0046A

|   |                                    |        |       |        |
|---|------------------------------------|--------|-------|--------|
| Applied model                             | VQ40DE                             |        |       |        |
| Final drive model                         | R180A                              |        |       |        |
| Transmission type                         | A/T                                |        | M/T   |        |
| Gear ratio                                | 3.133                              | 3.357* | 3.538 | 3.692* |
| Number of teeth (Drive gear/Drive pinion) | 47/15                              | 47/14  | 46/13 | 48/13  |
| Differential gear oil capacity (Approx.)  | 0.85 ℓ (1-3/4 US pt, 1-1/2 Imp pt) |        |       |        |
| Number of pinion gears                    | 2                                  |        |       |        |
| Drive pinion adjustment spacer type       | Collapsible                        |        |       |        |

\*:Option

### Inspection and Adjustment DRIVE GEAR RUNOUT

EDS0046B

Unit: mm (in)

| Item                 | Runout limit          |
|----------------------|-----------------------|
| Drive gear back face | 0.08 (0.0031) or less |

### SIDE GEAR CLEARANCE

Unit: mm (in)

| Item  | Specification  |
|---|--|
| Side gear back clearance (Clearance between side gear and differential case for adjusting side gear backlash) | 0.1 (0.004) or less<br>(Each gear should rotate smoothly without excessive resistance during differential motion.) |

### PRELOAD TORQUE

Unit: N·m (kg·m, in·lb)

| Item  | Specification                      |
|---|------------------------------------|
| Drive pinion bearing preload torque   | 1.08 - 1.66 (0.11 - 0.16, 10 - 14) |
| Side bearing preload torque   | 0.59 - 1.08 (0.06 - 0.11, 6 - 9)   |
| Total preload torque<br>(Total preload torque = drive pinion bearing preload torque + side bearing preload torque). | 1.67 - 2.74 (0.17 - 0.27, 15 - 24) |

### BACKLASH

Unit: mm (in)

| Item                                | Specification                 |
|-------------------------------------|-------------------------------|
| Drive gear to drive pinion backlash | 0.10 - 0.15 (0.0039 - 0.0059) |

### COMPANION FLANGE RUNOUT

Unit: mm (in)

| Item                        | Runout limit        |
|-----------------------------|---------------------|
| Companion flange face       | 0.1 (0.004) or less |
| Companion flange inner side | 0.1 (0.004) or less |

# SERVICE DATA AND SPECIFICATIONS (SDS)

## SELECTIVE PARTS

### Drive Pinion Height Adjusting Washer

Unit: mm (in)

| Thickness     | Part number* | Thickness     | Part number* |
|---------------|--------------|---------------|--------------|
| 3.09 (0.1217) | 38154 EA000  | 3.39 (0.1335) | 38154 EA010  |
| 3.12 (0.1228) | 38154 EA001  | 3.42 (0.1346) | 38154 EA011  |
| 3.15 (0.1240) | 38154 EA002  | 3.45 (0.1358) | 38154 EA012  |
| 3.18 (0.1252) | 38154 EA003  | 3.48 (0.1370) | 38154 EA013  |
| 3.21 (0.1264) | 38154 EA004  | 3.51 (0.1382) | 38154 EA014  |
| 3.24 (0.1276) | 38154 EA005  | 3.54 (0.1394) | 38154 EA015  |
| 3.27 (0.1287) | 38154 EA006  | 3.57 (0.1406) | 38154 EA016  |
| 3.30 (0.1299) | 38154 EA007  | 3.60 (0.1417) | 38154 EA017  |
| 3.33 (0.1311) | 38154 EA008  | 3.63 (0.1429) | 38154 EA018  |
| 3.36 (0.1323) | 38154 EA009  | 3.66 (0.1441) | 38154 EA019  |

\*: Always check with the Parts Department for the latest parts information.

### Side Gear Thrust Washer

Unit: mm (in)

| Thickness     | Part number* | Thickness     | Part number* |
|---------------|--------------|---------------|--------------|
| 0.75 (0.0295) | 38424 W2010  | 0.87 (0.0343) | 38424 W2014  |
| 0.78 (0.0307) | 38424 W2011  | 0.90 (0.0354) | 38424 W2015  |
| 0.81 (0.0319) | 38424 W2012  | 0.93 (0.0366) | 38424 W2016  |
| 0.84 (0.0331) | 38424 W2013  | 0.96 (0.0378) | 38424 W2017  |

\*: Always check with the Parts Department for the latest parts information.

### Side Bearing Adjusting Washer

Unit: mm (in)

| Thickness     | Part number* | Thickness     | Part number* |
|---------------|--------------|---------------|--------------|
| 1.95 (0.0768) | 38453 EA000  | 2.35 (0.0925) | 38453 EA008  |
| 2.00 (0.0787) | 38453 EA001  | 2.40 (0.0945) | 38453 EA009  |
| 2.05 (0.0807) | 38453 EA002  | 2.45 (0.0965) | 38453 EA010  |
| 2.10 (0.0827) | 38453 EA003  | 2.50 (0.0984) | 38453 EA011  |
| 2.15 (0.0846) | 38453 EA004  | 2.55 (0.1004) | 38453 EA012  |
| 2.20 (0.0866) | 38453 EA005  | 2.60 (0.1024) | 38453 EA013  |
| 2.25 (0.0886) | 38453 EA006  | 2.65 (0.1043) | 38453 EA014  |
| 2.30 (0.0906) | 38453 EA007  |               |              |

\*: Always check with the Parts Department for the latest parts information.

A  
B  
C  
FFD  
E  
F  
G  
H  
I  
J  
K  
L  
M

# SERVICE DATA AND SPECIFICATIONS (SDS)

---