

A  
B  
C

# WT

## SECTION

### ROAD WHEELS & TIRES

## CONTENTS

WT

<p><b>PREPARATION</b> ..... 2</p> <p style="padding-left: 20px;">Special Service Tool ..... 2</p> <p><b>NOISE, VIBRATION, AND HARSHNESS (NVH)</b></p> <p><b>TROUBLESHOOTING</b> ..... 3</p> <p style="padding-left: 20px;">NVH Troubleshooting Chart ..... 3</p> <p><b>WHEEL</b> ..... 4</p> <p style="padding-left: 20px;">Inspection ..... 4</p> <p><b>WHEEL AND TIRE ASSEMBLY</b> ..... 5</p> <p style="padding-left: 20px;">Balancing Wheels ..... 5</p> <p style="padding-left: 40px;">REMOVAL ..... 5</p> <p style="padding-left: 40px;">WHEEL BALANCE ADJUSTMENT ..... 5</p> <p style="padding-left: 20px;">Rotation ..... 6</p> <p><b>LOW TIRE PRESSURE WARNING SYSTEM</b> ..... 7</p> <p style="padding-left: 20px;">System Components ..... 7</p> <p style="padding-left: 20px;">System Description ..... 7</p> <p style="padding-left: 40px;">TRANSMITTER (PRESSURE SENSOR) ..... 7</p> <p style="padding-left: 40px;">ANTENNA ..... 8</p> <p style="padding-left: 40px;">LOW TIRE PRESSURE WARNING CONTROL UNIT ..... 8</p> <p><b>TROUBLE DIAGNOSES</b> ..... 9</p> <p style="padding-left: 20px;">Wiring Diagram ..... 9</p> <p style="padding-left: 20px;">ID Registration Procedure ..... 11</p> <p style="padding-left: 40px;">ID REGISTRATION WITH TRANSMITTER ACTIVATION TOOL ..... 11</p> <p style="padding-left: 40px;">ID REGISTRATION WITHOUT TRANSMITTER ACTIVATION TOOL ..... 12</p> <p style="padding-left: 20px;">Self-Diagnosis ..... 12</p> <p style="padding-left: 40px;">DESCRIPTION ..... 12</p> <p style="padding-left: 40px;">FUNCTION ..... 12</p> <p style="padding-left: 40px;">CONSULT-II ..... 12</p> <p style="padding-left: 20px;">How to Perform Trouble Diagnosis for Quick and Accurate Repair ..... 13</p> <p style="padding-left: 40px;">INTRODUCTION ..... 13</p> <p style="padding-left: 40px;">WORK FLOW ..... 14</p> <p style="padding-left: 20px;">Preliminary Check ..... 14</p> <p style="padding-left: 40px;">BASIC INSPECTION ..... 14</p> <p style="padding-left: 20px;">Malfunction Code/Symptom Chart ..... 16</p>	<p><b>TROUBLE DIAGNOSIS FOR SELF-DIAGNOSTIC ITEMS</b> ..... 17</p> <p style="padding-left: 20px;">Inspection 1: Transmitter or Low Tire Pressure Warning Control Unit ..... 17</p> <p style="padding-left: 40px;">MALFUNCTION CODE NO. 21, 22, 23 OR 24 ... 17</p> <p style="padding-left: 20px;">Inspection 2: Transmitter ..... 17</p> <p style="padding-left: 40px;">MALFUNCTION CODE NO. 31, 32, 33, 34, 35, 36, 37, 38, 41, 42, 43, 44, 45, 46, 47 OR 48 ..... 17</p> <p style="padding-left: 20px;">Inspection 3: Low Tire Pressure Warning Control Unit ..... 17</p> <p style="padding-left: 40px;">MALFUNCTION CODE NO. 51 ..... 17</p> <p><b>TROUBLE DIAGNOSIS FOR SYMPTOMS</b> ..... 18</p> <p style="padding-left: 20px;">Inspection 1: Warning Lamp Does Not Come On When Ignition Switch Is Turned On ..... 18</p> <p style="padding-left: 40px;">DIAGNOSTIC PROCEDURE ..... 18</p> <p style="padding-left: 20px;">Inspection 2: Warning Lamp Stays On When Ignition Switch Is Turned On ..... 19</p> <p style="padding-left: 40px;">DIAGNOSTIC PROCEDURE ..... 19</p> <p style="padding-left: 20px;">Inspection 3: Warning Lamp Blinks When Ignition Switch Is Turned On ..... 20</p> <p style="padding-left: 40px;">DIAGNOSTIC PROCEDURE ..... 20</p> <p style="padding-left: 20px;">Inspection 4: Hazard Warning Lamp Blinks When Ignition Switch Is Turned On ..... 21</p> <p style="padding-left: 40px;">DIAGNOSTIC PROCEDURE ..... 21</p> <p style="padding-left: 20px;">Inspection 5: ID Registration Cannot Be Completed.. 21</p> <p style="padding-left: 40px;">DIAGNOSTIC PROCEDURE ..... 21</p> <p style="padding-left: 20px;">Electrical Components Inspection ..... 22</p> <p style="padding-left: 40px;">LOW TIRE PRESSURE WARNING RELAY ..... 22</p> <p><b>REMOVAL AND INSTALLATION</b> ..... 23</p> <p style="padding-left: 20px;">Transmitter (Pressure Sensor) ..... 23</p> <p style="padding-left: 40px;">REMOVAL ..... 23</p> <p style="padding-left: 40px;">INSTALLATION ..... 23</p> <p><b>SERVICE DATA AND SPECIFICATIONS (SDS)</b> ..... 25</p> <p style="padding-left: 20px;">Road Wheel ..... 25</p> <p style="padding-left: 20px;">Tire ..... 25</p>
---	--

F  
G  
H  
I  
J  
K  
L  
M

# PREPARATION

## PREPARATION

PF0:00002

### Special Service Tool

EES000LC

The actual shapes of Kent-Moore tools may differ from those of special service tools illustrated here.

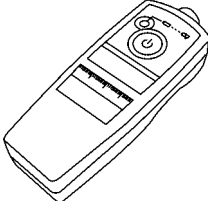
Tool number (Kent-Moore No.) Tool name	Description
(J-45295) Transmitter activation tool  LEIA0035E	ID registration

# NOISE, VIBRATION, AND HARSHNESS (NVH) TROUBLESHOOTING

## NOISE, VIBRATION, AND HARSHNESS (NVH) TROUBLESHOOTING

PF0:0003

### NVH Troubleshooting Chart

EES000LD

Use the chart below to help you find the cause of the symptom. If necessary, repair or replace these parts.

Reference page		WT-25	WT-25	WT-25	WT-5	—	—	WT-25	RAX-5	FAX-4, FSU-4	RAX-5, RSU-4	Refer to TIRES in this chart.	Refer to ROAD WHEEL in this chart.	BR-5	PS-5	
Possible cause and SUSPECTED PARTS		Out-of-round	Imbalance	Incorrect tire pressure	Uneven tire wear	Deformation or damage	Non-uniformity	Incorrect tire size	DIFFERENTIAL	FRONT AXLE AND FRONT SUSPENSION	REAR AXLE AND REAR SUSPENSION	TIRES	ROAD WHEEL	BRAKE	STEERING	
Symptom	TIRES	Noise	x	x	x	x	x	x	x	x	x	x		x	x	
		Shake	x	x	x	x	x		x		x	x		x	x	
		Vibration			x				x		x	x	x			x
		Shimmy	x	x	x	x	x	x	x		x	x	x		x	x
		Judder	x	x	x	x	x		x		x	x	x		x	x
	Poor quality ride or handling	x	x	x	x	x		x		x	x	x				
	ROAD WHEEL	Noise	x	x			x			x	x	x		x	x	x
		Shake	x	x			x				x	x		x	x	x
Shimmy, judder		x	x			x				x	x		x	x	x	
Poor quality ride or handling		x	x			x				x	x		x			

x: Applicable

A  
B  
C  
D  
E  
F  
G  
H  
I  
J  
K  
L  
M

WT

# WHEEL

## WHEEL

PFP:40300

### Inspection

EES000LE

1. Check tires for wear and improper inflation.
2. Check wheels for deformation, cracks and other damage. If deformed, remove wheel and check wheel runout.
  - a. Remove tire from wheel and mount wheel on a tire balance machine.
  - b. Set dial indicator as shown in the illustration. Refer to [WT-25, "Road Wheel"](#).
3. Check front wheel bearings for looseness.
4. Check front suspension for looseness.

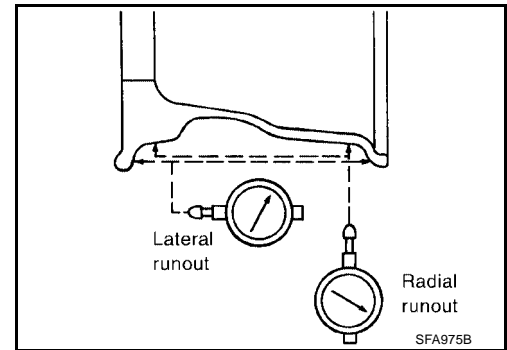

# WHEEL AND TIRE ASSEMBLY

PF:40300

## WHEEL AND TIRE ASSEMBLY

EES000LF

### Balancing Wheels REMOVAL

1. Remove inner and outer balance weights from the wheel.

**CAUTION:**

- Be careful not to scratch the wheel during removal.

2. Using releasing agent, remove double-faced adhesive tape from the wheel.

**CAUTION:**

- Be careful not to scratch the wheel during removal.
- After removing double-faced adhesive tape, wipe clean traces of releasing agent from the wheel.

### WHEEL BALANCE ADJUSTMENT

- If a tire balance machine has adhesion balance weight mode settings and drive-in weight mode setting, select and adjust a drive-in weight mode suitable for wheels.

1. Set wheel on wheel balancer using the center hole as a guide. Start the tire balance machine.
2. When inner and outer imbalance values are shown on the wheel balancer indicator, multiply outer imbalance value by 1.6 to determine balance weight that should be used. Select the outer balance weight with a value closest to the calculated value and install it to the designated outer position of, or at the designated angle in relation to the road wheel.

**CAUTION:**

- Do not install the inner balance weight before installing the outer balance weight.
- Before installing the balance weight, be sure to clean the mating surface of the wheel.

Indicated imbalance value  $\times 5/3 =$  balance weight to be installed

Calculation example:

23 g (0.81 oz)  $\times 5/3 = 38.33$  g (1.35 oz) = 40 g (1.41 oz) balance weight (closer to calculated balance weight value)

Note that balance weight value must be closer to the calculated balance weight value.

Example:

37.4 g = 35 g (1.23 oz)

37.5 g = 40 g (1.41 oz)

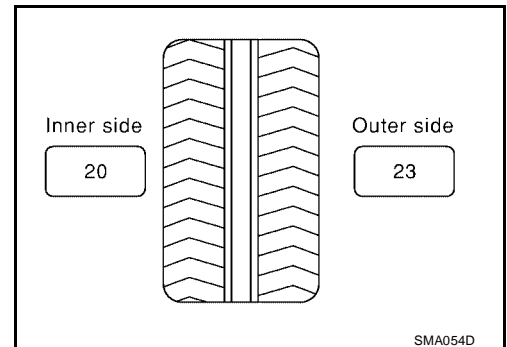

# WHEEL AND TIRE ASSEMBLY

- Install balance weight in the position shown.
- When installing balance weight to wheels, set it into the grooved area on the inner wall of the wheel as shown so that the balance weight center is aligned with the wheel balancer indication position (angle).

**CAUTION:**

- Always use genuine Nissan adhesion balance weights.
- Balance weights are not reusable; always replace with new ones.
- Do not install more than three sheets of balance weights.

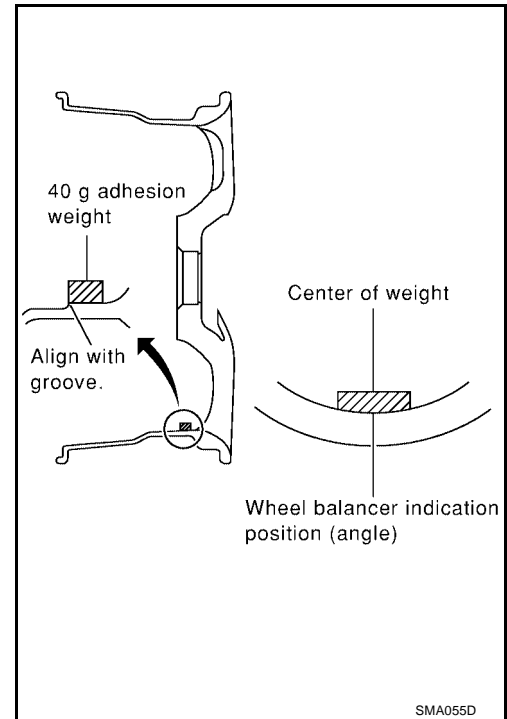

- If calculated balance weight value exceeds 50 g (1.76 oz), install two balance weight sheets in line with each other as shown.

**CAUTION:**

**Do not install one balance weight sheet on top of another.**

- Start wheel balancer again.
- Install drive-in balance weight on inner side of road wheel in the wheel balancer indication position (angle).

**CAUTION:**

**Do not install more than two balance weights.**

- Start wheel balancer. Make sure that inner and outer residual imbalance values are 10 g (0.35 oz) each or below.

- If either residual imbalance value exceeds 10 g (0.35 oz), repeat installation procedures.

**Wheel balance (Maximum allowable imbalance):**

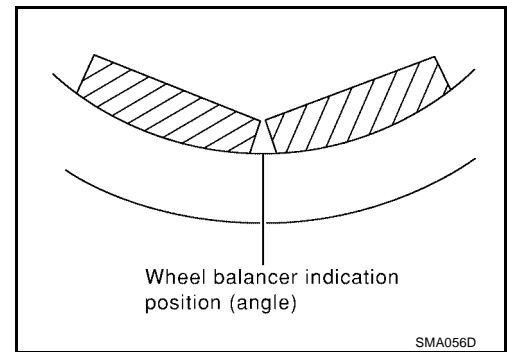

Maximum allowable imbalance	Dynamic (At rim flange)	10 g (0.35 oz) (one side)
	Static	20 g (0.71 oz)

## Rotation

EES000LG

- Follow the maintenance schedule for tire rotation service intervals. Refer to [MA-7, "PERIODIC MAINTENANCE"](#).
- Do not include the T-type spare tire when rotating the tires.

**CAUTION:**

**When installing wheels, tighten them diagonally by dividing the work two to three times in order to prevent the wheels from developing any distortion.**

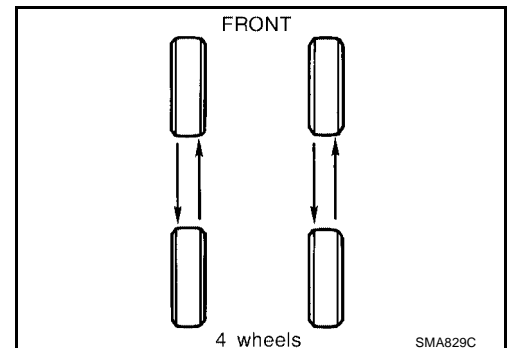

Tightening torque of wheel nut : 118 - 147 N·m (12 - 15 kg·m, 87 - 108 ft·lb)

# LOW TIRE PRESSURE WARNING SYSTEM

## LOW TIRE PRESSURE WARNING SYSTEM

PF:40300

### System Components

EES000LH

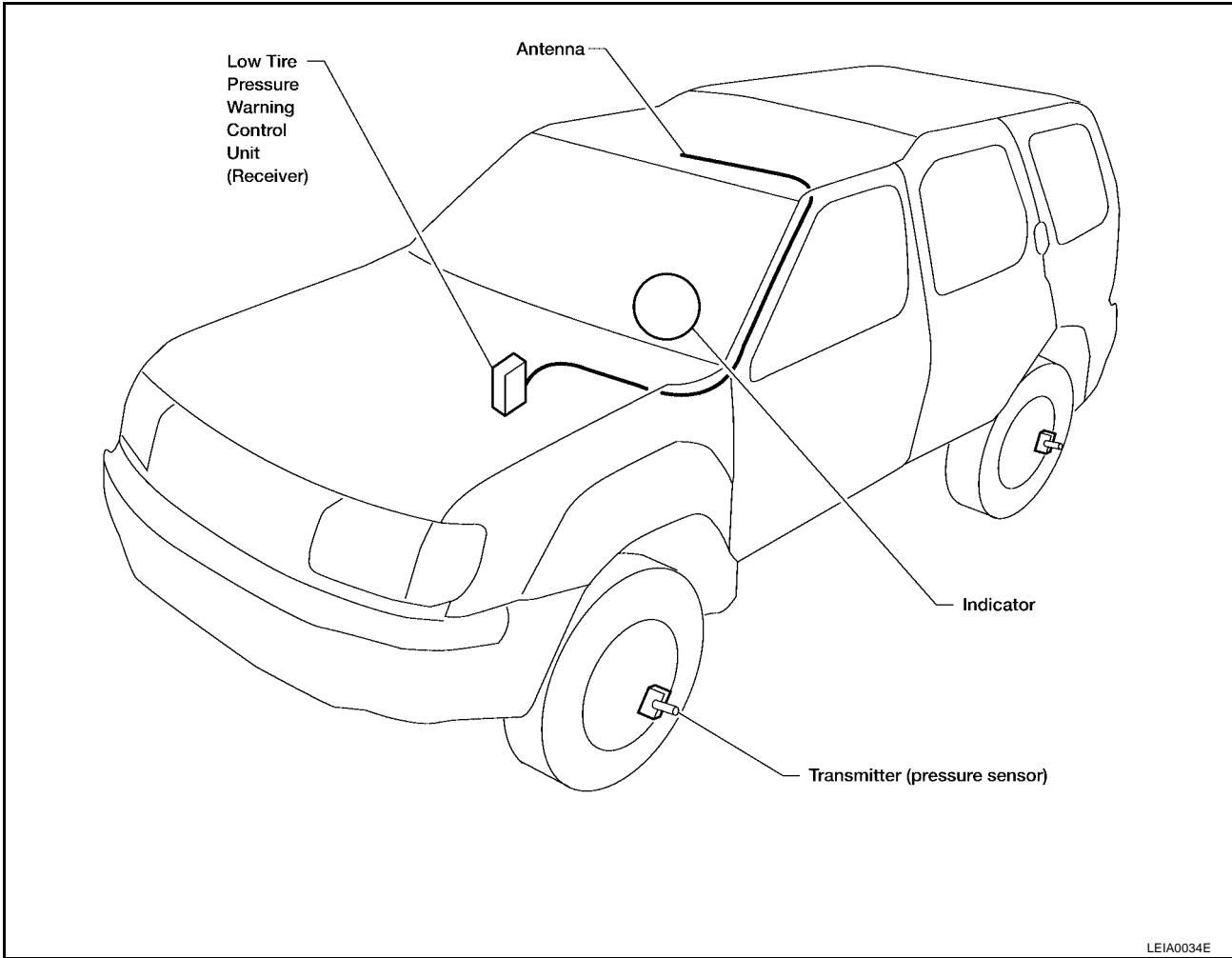

LEIA0034E

### System Description TRANSMITTER (PRESSURE SENSOR)

EES000LI

A transmitter (pressure sensor) integrated with a valve is installed on each wheel and transmits a detected air pressure signal in the form of a radio wave.

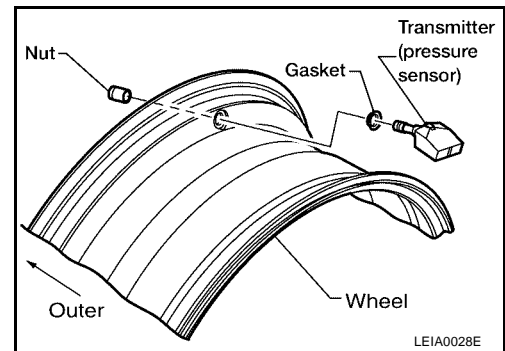

LEIA0028E

A  
B  
C  
D  
WT  
F  
G  
H  
I  
J  
K  
L  
M

# LOW TIRE PRESSURE WARNING SYSTEM

## ANTENNA

Receives the radio wave signal transmitted by the transmitter (pressure sensor).

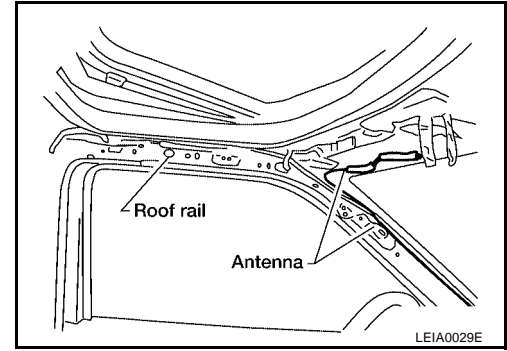

## LOW TIRE PRESSURE WARNING CONTROL UNIT

Reads the radio wave signal received by the antenna, and controls the warning lamp and the warning chime operations as shown below. It also has a judgement function to detect a system malfunction.

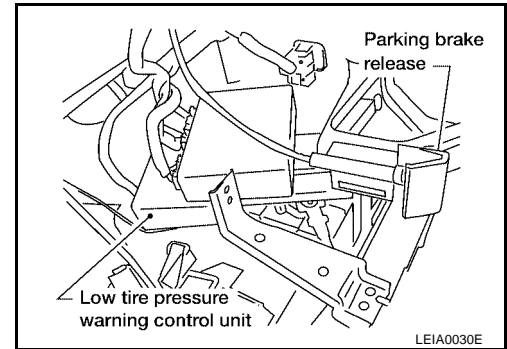

Condition	Warning lamp	Warning chime
Less than 192 kPa (1.9 kg/cm <sup>2</sup> , 27.8 psi) [Low Pressure]	ON	Sounds for 10 sec.
System malfunction	ON	OFF



# TROUBLE DIAGNOSES

## TROUBLE DIAGNOSES

### Wiring Diagram

PF0:0004

EES000LJ

## WT-T/WARN-01

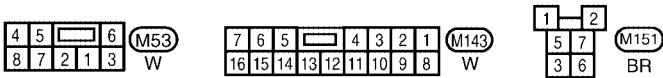
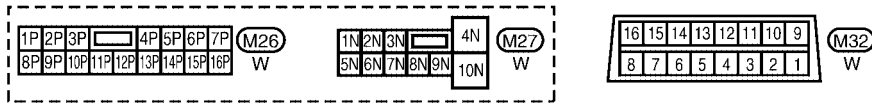
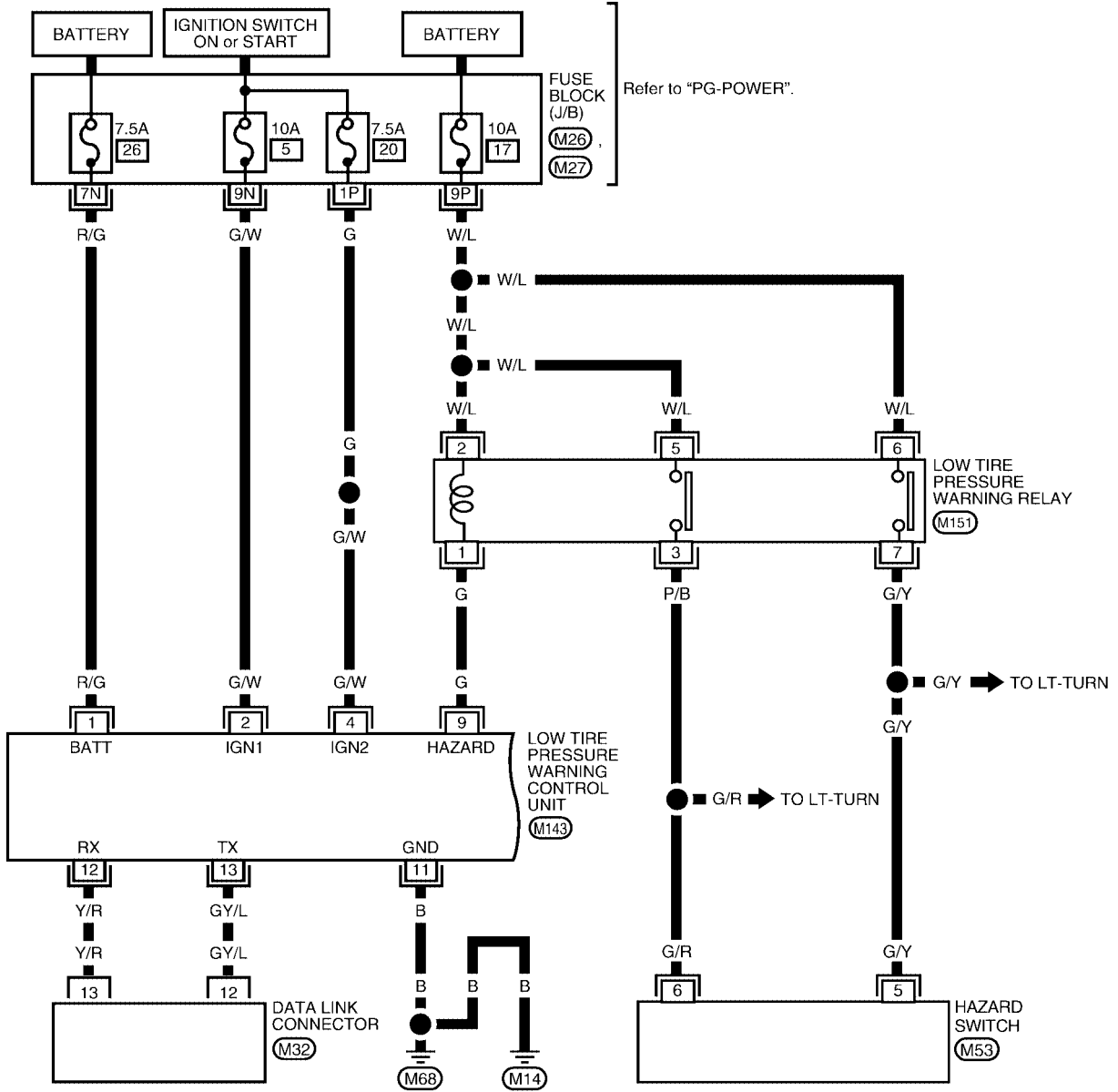

A  
B  
C  
D  
WT  
F  
G  
H  
I  
J  
K  
L  
M

# TROUBLE DIAGNOSES

WT-T/WARN-02

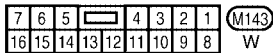
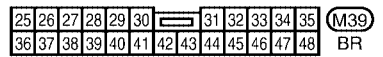
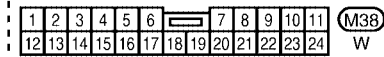
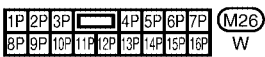
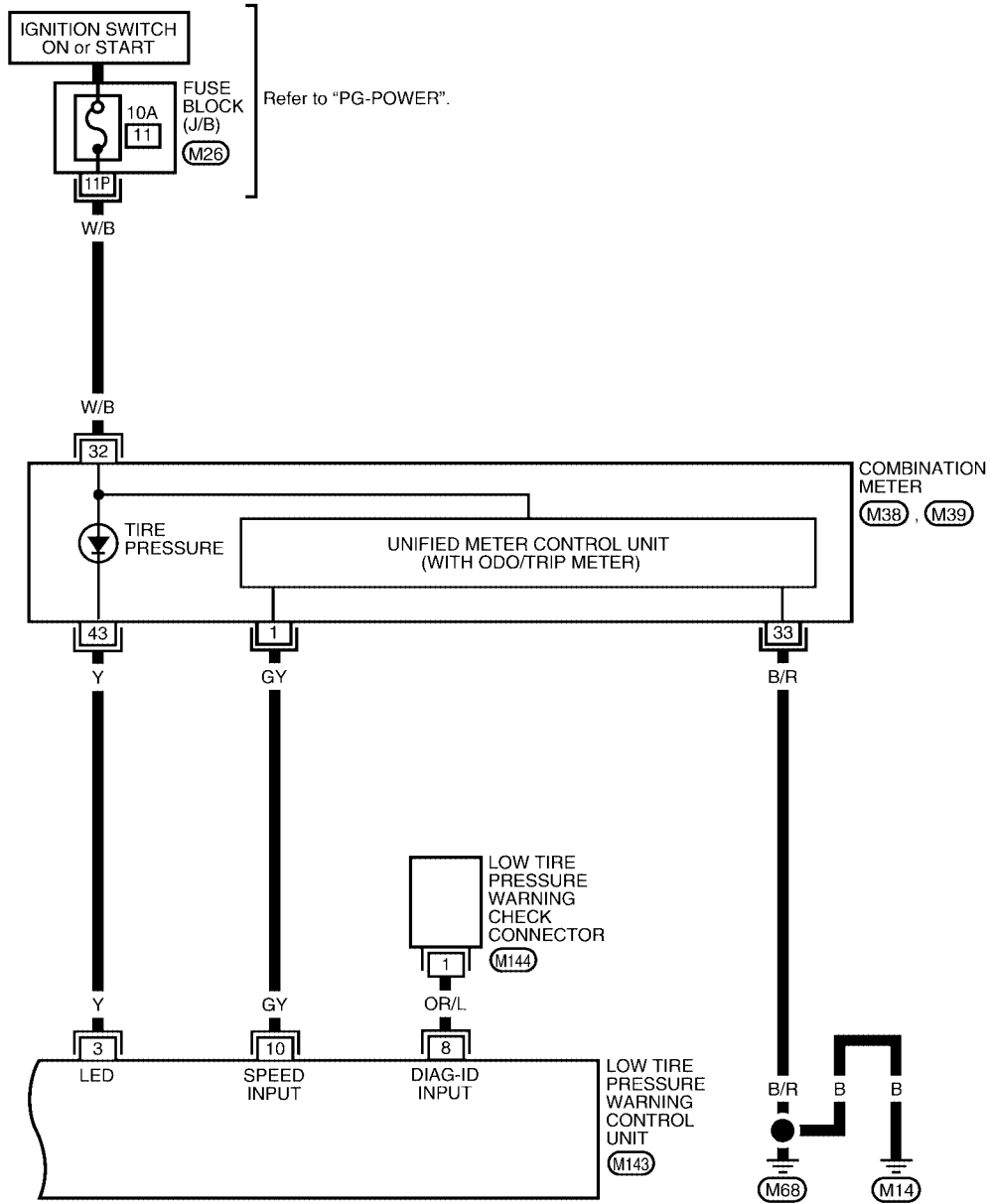

# TROUBLE DIAGNOSES

EES000LK

## ID Registration Procedure

### ID REGISTRATION WITH TRANSMITTER ACTIVATION TOOL

1. Turn ignition switch "OFF".
2. Connect CONSULT-II to data link connector.
3. Start engine.
4. Touch "START", "AIR PRESSURE MONITOR", "WORK SUPPORT" and "ID REGIST".
5. Touch "START" on the CONSULT-II.
6. With the transmitter activation tool (J-45295) pushed against the front-left transmitter, press the button. The LED illuminates for approximately 5 seconds.

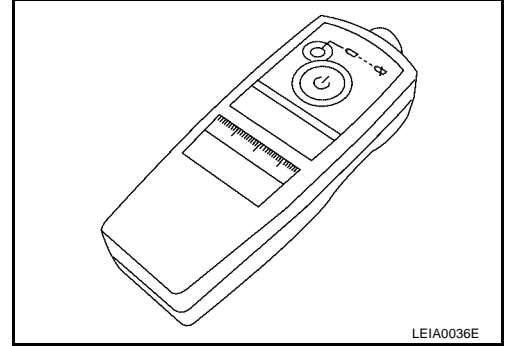

LEIA0036E

7. Register the IDs in order from FR LH, FR RH, RR RH, to RR LH. When ID registration of each wheel has been completed, a chime sounds and hazard warning lamp blinks.

Activation tire position	Chime	Hazard warning lamp	CONSULT-II
1	FR LH	Once	"YET" ↓ "DONE"
2	FR RH	2 times	
3	RR RH	3 times	
4	RR LH	4 times	
		Flashes 2 times	

8. After completing all ID registrations, press "END" to complete the procedure.

**NOTE:**

Be sure to register the IDs in the designated order or the self-diagnostic results display will not function properly.

# TROUBLE DIAGNOSES

## ID REGISTRATION WITHOUT TRANSMITTER ACTIVATION TOOL

1. Turn ignition switch "OFF".
2. Connect CONSULT-II to data link connector.
3. Start engine.
4. Touch "START", "AIR PRESSURE MONITOR", "WORK" SUPPORT" and "ID REGIST".
5. Touch "START" on the CONSULT-II.
6. Adjust the tire pressure to the values shown in the table below for ID registration, and drive the vehicle at 32 km/h (20 MPH) or more for a few minutes.

Tire position	Tire pressure kPa (kg/cm <sup>2</sup> , psi)
Front-Left	260 (2.6, 38)
Front-Right	240 (2.4, 35)
Rear-Right	220 (2.2, 32)
Rear-Left	200 (2.0, 29)

7. When ID registration of each wheel has been completed, a chime sounds and hazard warning lamp blinks.

Activation tire position	Chime	Hazard warning lamp	CONSULT-II
1 FR LH	Once	Flashes 2 times	"YET" ↓ "DONE"
2 FR RH	2 times		
3 RR RH	3 times		
4 RR LH	4 times		

8. After completing all ID registrations, press "END" to complete the procedure.

## Self-Diagnosis DESCRIPTION

EES000LL

While driving, the low tire pressure warning system receives the signal transmitted from the transmitter installed in each wheel, and signals the driver when the tire pressure becomes low. The control unit of this system has pressure judgement and trouble diagnosis functions.

## FUNCTION

When the low tire pressure warning system detects low inflation pressure or another unusual symptom, the warning lamp on the instrument panel comes on. To start the self-diagnostic results mode, ground the self-diagnostic (check) terminal. The malfunction location is indicated by the warning lamp flashing and the chime sounds.

## CONSULT-II

### CONSULT-II Application to Low Tire Pressure Warning System

ITEM	SELF-DIAGNOSTIC RESULTS	DATA MONITOR
Front - Left transmitter	×	×
Front - Right transmitter	×	×
Rear - Left transmitter	×	×
Rear - Right transmitter	×	×
Warning lamp	—	×
Vehicle speed	—	×
Warning chime (in control unit)	—	×

×: Applicable

—: Not applicable

# TROUBLE DIAGNOSES

## Self-Diagnostic Results Mode

Diagnostic item	Diagnostic item is detected when...
FLAT - TIRE - FL FLAT - TIRE - FR FLAT - TIRE - RR FLAT - TIRE - RL	Front-left tire pressure drops to 192 kPa (1.9 kg/cm <sup>2</sup> , 27.8 psi) or less Front-right tire pressure drops to 192 kPa (1.9 kg/cm <sup>2</sup> , 27.8 psi) or less Rear-right tire pressure drops to 192 kPa (1.9 kg/cm <sup>2</sup> , 27.8 psi) or less Rear-left tire pressure drops to 192 kPa (1.9 kg/cm <sup>2</sup> , 27.8 psi) or less
[NO-DATA] - FL [NO-DATA] - FR [NO-DATA] - RR [NO-DATA] - RL	Data from front-left transmitter cannot be received. Data from front-right transmitter cannot be received. Data from rear-right transmitter cannot be received. Data from rear-left transmitter cannot be received.
[CHECKSUM- ERR] - FL [CHECKSUM- ERR] - FR [CHECKSUM- ERR] - RR [CHECKSUM- ERR] - RL	Checksum data from front-left transmitter is malfunctioning. Checksum data from front-right transmitter is malfunctioning. Checksum data from rear-right transmitter is malfunctioning. Checksum data from rear-left transmitter is malfunctioning.
[PRESSDATA- ERR] - FL [PRESSDATA- ERR] - FR [PRESSDATA- ERR] - RR [PRESSDATA- ERR] - RL	Air pressure data from front-left transmitter is malfunctioning. Air pressure data from front-right transmitter is malfunctioning. Air pressure data from rear-right transmitter is malfunctioning. Air pressure data from rear-left transmitter is malfunctioning.
[CODE- ERR] - FL [CODE- ERR] - FR [CODE- ERR] - RR [CODE- ERR] - RL	Function code data from front-left transmitter is malfunctioning. Function code data from front-right transmitter is malfunctioning. Function code data from rear-right transmitter is malfunctioning. Function code data from rear-left transmitter is malfunctioning.
[BATT - VOLT - LOW] - FL [BATT - VOLT - LOW] - FR [BATT - VOLT - LOW] - RR [BATT - VOLT - LOW] - RL	Battery voltage of front-left transmitter drops. Battery voltage of front-right transmitter drops. Battery voltage of rear-right transmitter drops. Battery voltage of rear-left transmitter drops.
RECEIVER - ID - NO - REG	No ID registration has been made to the low tire pressure warning control unit.

### NOTE:

Before performing the self-diagnosis, be sure to register the ID to make sure the actual malfunction location is correctly displayed on CONSULT-II.

## Data Monitor Mode

MONITOR	CONDITION	SPECIFICATION
VEHICLE SPEED	Drive vehicle.	Vehicle speed (km/h or MPH)
PRESSURE FL PRESSURE FR PRESSURE RR PRESSURE RL	1. Drive vehicle for a few minutes. or 2. Ignition switch ON and activation tool is transmitting activation signals.	Tire pressure (kPa or psi)
ID FL ID FR ID RR ID RL	Ignition switch ON	Registration ID: DONE No registration ID: YET
WARNING LAMP		Warning lamp on: ON Warning lamp off: OFF
BUZZER		Chime in low tire pressure warning control unit on: ON Chime in low tire pressure warning control unit off: OFF

### NOTE:

Before performing the self-diagnosis, be sure to register the ID to make sure the actual malfunction location is correctly displayed on CONSULT-II.

## How to Perform Trouble Diagnosis for Quick and Accurate Repair

EES000LM

### INTRODUCTION

- Before troubleshooting, verify the customer concern.
- If a vehicle concern is difficult to reproduce, harnesses, harness connectors or terminals may be the cause. Hold and shake these parts to make sure they are securely connected.

# TROUBLE DIAGNOSES

- When using a circuit tester to measure voltage or resistance of each circuit, be careful not to expand connector terminals.

## WORK FLOW

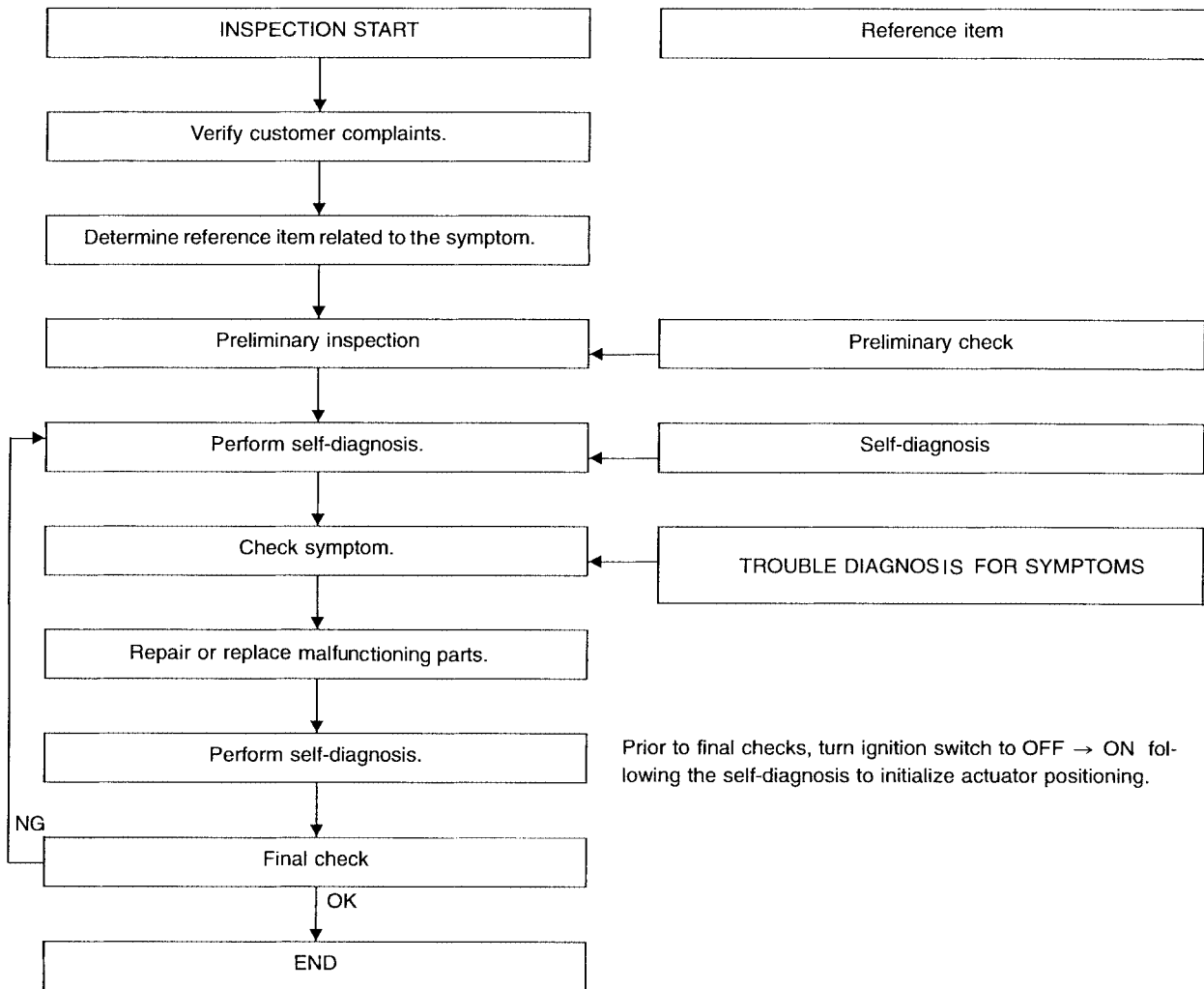

SEIA0100E

EES000LN

## Preliminary Check BASIC INSPECTION

### 1. CHECK ALL TIRE PRESSURES

- Check all tire pressures.

**Tire pressure : 240 kPa (2.4 kg/cm<sup>2</sup> , 35 psi)**

OK or NG

OK >> GO TO 2.

NG >> Adjust tire pressures to specified value.

# TROUBLE DIAGNOSES

---

## 2. CHECK WARNING LAMP ACTIVATION

---

- Check warning lamp activation.

**Warning lamp should activate for 1 second when ignition switch is turned ON.**

OK or NG

OK >> GO TO 3.

NG >> Check fuse and combination meter.

---

## 3. CHECK CONNECTOR

---

1. Disconnect low tire pressure warning control unit harness connector.
2. Check pin terminals for damage.
3. Reconnect harness connector.

OK or NG

OK >> GO TO 4.

NG >> Repair or replace damaged parts.

---

## 4. CHECK TRANSMITTER ACTIVATION TOOL BATTERY

---

- Check transmitter tool battery.

OK or NG

OK >> Carry out self-diagnosis.

NG >> Replace transmitter activation tool battery.

A

B

C

D

WT

F

G

H

I

J

K

L

M

# TROUBLE DIAGNOSES

## Malfunction Code/Symptom Chart

EES000LO

Code/Symptom	Malfunction part	Reference page
21 22 23 24	Transmitter no data (front - left) Transmitter no data (front - right) Transmitter no data (rear - right) Transmitter no data (rear - left)	<a href="#">WT-17</a>
31 32 33 34	Transmitter checksum error (front - left) Transmitter checksum error (front - right) Transmitter checksum error (rear - right) Transmitter checksum error (rear - left)	<a href="#">WT-17</a>
35 36 37 38	Transmitter pressure data error (front - left) Transmitter pressure data error (front - right) Transmitter pressure data error (rear - right) Transmitter pressure data error (rear - left)	<a href="#">WT-17</a>
41 42 43 44	Transmitter function code error (front - left) Transmitter function code error (front - right) Transmitter function code error (rear - right) Transmitter function code error (rear - left)	<a href="#">WT-17</a>
45 46 47 48	Transmitter battery voltage low (front - left) Transmitter battery voltage low (front - right) Transmitter battery voltage low (rear - right) Transmitter battery voltage low (rear - left)	<a href="#">WT-17</a>
51	Low tire pressure warning control unit	<a href="#">WT-17</a>
Warning lamp does not come on when ignition switch is turned on.	Fuse or combination meter Low tire pressure warning control unit connector or circuit Low tire pressure warning control unit	<a href="#">WT-18</a>
Warning lamp stays on when ignition switch is turned on.	Fuse or combination meter Low tire pressure warning control unit connector or circuit Low tire pressure warning control unit	<a href="#">WT-19</a>
Warning lamp blinks when ignition switch is turned on.	Low tire pressure warning control unit harness connector or circuit Low tire pressure warning control unit	<a href="#">WT-20</a>
Hazard warning lamp blinks when ignition switch is turned on.	Low tire pressure warning control unit harness connector or circuit Low tire pressure warning control unit Low tire pressure warning relay	<a href="#">WT-21</a>
ID registration cannot be operated.	Transmitter Antenna harness connector or circuit Antenna	<a href="#">WT-21</a>



# TROUBLE DIAGNOSIS FOR SELF-DIAGNOSTIC ITEMS

## TROUBLE DIAGNOSIS FOR SELF-DIAGNOSTIC ITEMS

PFP:00000

### Inspection 1: Transmitter or Low Tire Pressure Warning Control Unit MALFUNCTION CODE NO. 21, 22, 23 OR 24

EES000LP

#### 1. CHECK CONNECTOR

- Disconnect low tire pressure warning control unit connector. Inspect control unit terminals and harness connector pins for damage or loose connections. Then, reconnect connector.
- Carry out self-diagnosis again.

OK or NG

OK >> **INSPECTION END**  
NG >> GO TO 2.

#### 2. CHECK ANTENNA CONNECTOR

- Check antenna and feeder connector for damage or loose connections.

OK or NG

OK >> GO TO 3.  
NG >> Repair or replace antenna or feeder connector.

#### 3. CHECK ANTENNA CIRCUIT

- Check antenna circuit continuity.

Does continuity exist?

Yes >> Check transmitter and transmitter activation tool.  
No >> Replace antenna circuit.

### Inspection 2: Transmitter

#### MALFUNCTION CODE NO. 31, 32, 33, 34, 35, 36, 37, 38, 41, 42, 43, 44, 45, 46, 47 OR 48

EES000LO

#### 1. ID REGISTRATION

- Carry out ID registration.
- Drive the vehicle for 5 minutes or longer for malfunction code Nos. 31, 32, 33, 34, 35, 36, 37, 38, 41, 42, 43, or 44. Drive the vehicle for 20 minutes or longer for malfunction code Nos. 45, 46, 47, or 48.

Does warning lamp activate?

Yes >> GO TO 2.  
No >> **INSPECTION END**

#### 2. REPLACE TRANSMITTER

- Replace the transmitter that corresponds with the malfunction code.

Does warning lamp activate again?

Yes >> GO TO 1.  
No >> **INSPECTION END**

### Inspection 3: Low Tire Pressure Warning Control Unit

#### MALFUNCTION CODE NO. 51

EES000LR

#### 1. SELF-DIAGNOSIS

- Carry out self-diagnosis.

Does warning lamp activate again?

Yes >> Replace low tire pressure warning control unit.  
No >> **INSPECTION END**

A

B

C

D

WT

F

G

H

I

J

K

L

M

# TROUBLE DIAGNOSIS FOR SYMPTOMS

## TROUBLE DIAGNOSIS FOR SYMPTOMS

PF0:0007

### Inspection 1: Warning Lamp Does Not Come On When Ignition Switch Is Turned On

EES000LS

#### DIAGNOSTIC PROCEDURE

### 1. CHECK COMBINATION METER

- Check combination meter operation.

OK or NG

OK >> GO TO 2.

NG >> Repair or replace combination meter.

### 2. CHECK WARNING LAMP

1. Disconnect low tire pressure warning control unit connector M143.
2. Apply ground to low tire pressure warning control unit connector M143 terminal 3 (Y).

Does the warning lamp activate?

Yes >> Replace low tire warning control unit.

No >> GO TO 3.

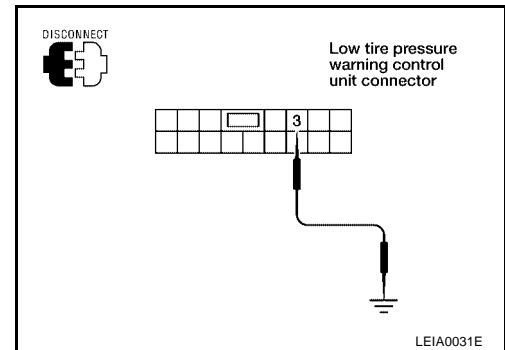

### 3. CHECK COMBINATION METER CIRCUIT

1. Disconnect combination meter connector M39.
2. Check continuity between low tire pressure warning control unit connector M143 terminal 3 (Y) and combination meter connector M39 terminal 43 (Y).

Terminals				Continuity
(+)		(-)		
Connector	Terminal (Wire color)	Connector	Terminal (Wire color)	
M143	3 (Y)	M39	43 (Y)	Yes

OK or NG

OK >> Check combination meter.

NG >> Check harness for open or short between low tire pressure warning control unit and combination meter.

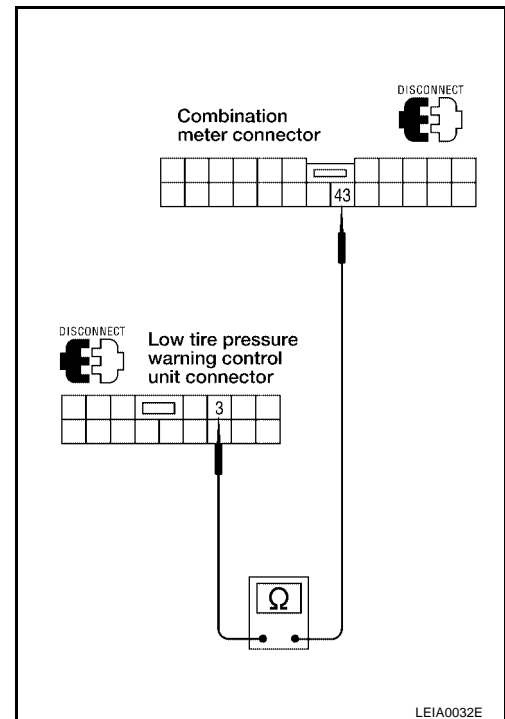

# TROUBLE DIAGNOSIS FOR SYMPTOMS

## Inspection 2: Warning Lamp Stays On When Ignition Switch Is Turned On

EES000LT

### 1. CHECK CIRCUIT

- Disconnect low tire pressure warning control unit connector M143 and combination meter connector M39.
- Check continuity between low tire pressure warning control unit connector M143 terminal 3 (Y) and combination meter connector M39 terminal 43 (Y).

Terminals				Continuity
(+)		(-)		
Connector	Terminal (Wire color)	Connector	Terminal (Wire color)	
M143	3 (Y)	M39	43 (Y)	Yes

#### OK or NG

OK >> GO TO 3.

NG >> Check harness for open or short between low tire pressure warning control unit and combination meter.

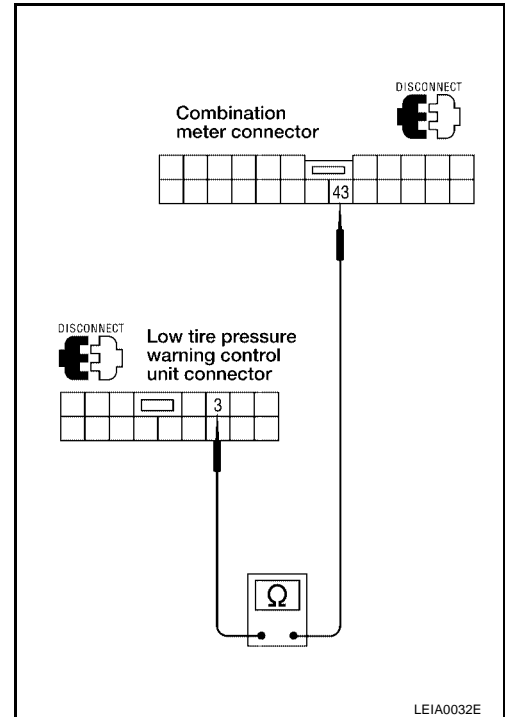

### 2. CHECK POWER SUPPLY CIRCUIT 1

- Check voltage between low tire pressure warning control unit connector M143 terminal 1 (R/G) and ground.

Terminals			Voltage (Approx.)
(+)		(-)	
Connector	Terminal (Wire color)	Ground	
M143	1 (R/G)		12V

#### OK or NG

OK >> GO TO 3.

NG >> Check low tire pressure warning control unit power supply circuit for open or short.

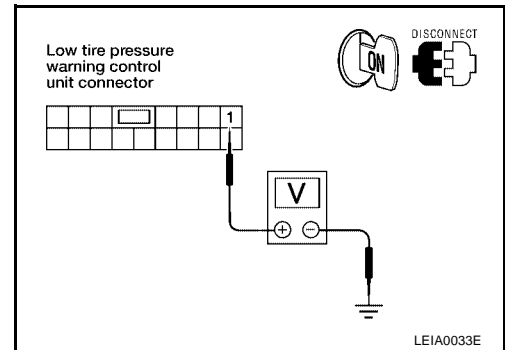

## TROUBLE DIAGNOSIS FOR SYMPTOMS

### 3. CHECK POWER SUPPLY CIRCUIT 2

1. Turn ignition switch ON.
2. Check voltage between low tire pressure warning control unit connector M143 terminal 2 (G/W), 4 (G/W) and ground.

Terminals		Voltage (Approx.)
(+)	(-)	
Connector	Terminal (Wire color)	Ground  12V
M143	2 (G/W)	
M143	4 (G/W)	

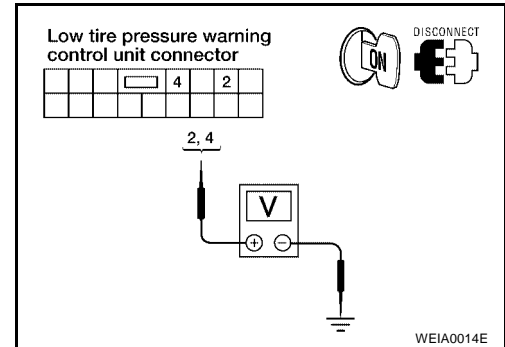

**OK or NG**

- OK >> GO TO 4.
- NG >> Check low tire pressure warning control unit power supply circuit for open or short.

### 4. CHECK GROUND CIRCUIT

- Check continuity between low tire pressure warning control unit connector M143 terminal 11(B) and ground.

Terminals		Continuity
(+)	(-)	
Connector	Terminal (Wire color)	Ground  Yes
M143	11 (B)	

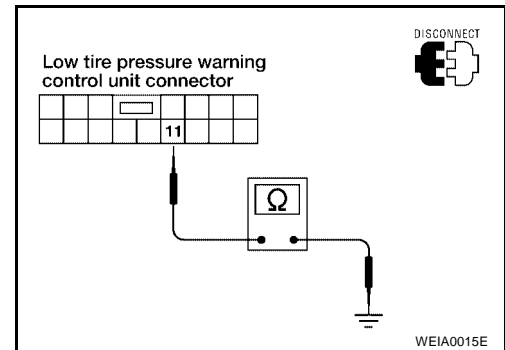

**OK or NG**

- OK >> Replace low tire pressure warning control unit.
- NG >> Repair or replace low tire pressure warning control unit ground circuit.

## Inspection 3: Warning Lamp Blinks When Ignition Switch Is Turned On

### DIAGNOSTIC PROCEDURE

EES000LU

#### 1. CHECK CIRCUIT

1. Disconnect low tire pressure warning control unit connector M143.
2. Check continuity between low tire pressure warning control unit connector M143 terminal 8(OR/L) and ground.

Terminals		Continuity
(+)	(-)	
Connector	Terminal (Wire color)	Ground  Yes
M143	8 (OR/L)	

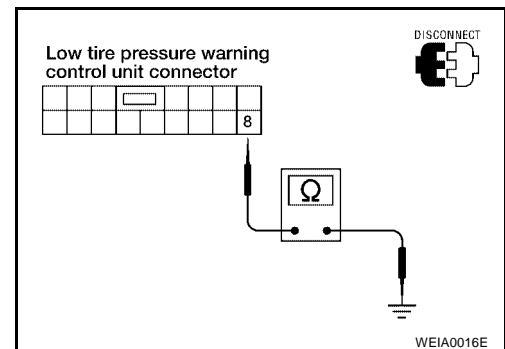

**OK or NG**

- OK >> Replace low tire pressure warning control unit.
- NG >> Repair circuit or harness connector.

# TROUBLE DIAGNOSIS FOR SYMPTOMS

## Inspection 4: Hazard Warning Lamp Blinks When Ignition Switch Is Turned On

EES000LV

### DIAGNOSTIC PROCEDURE

#### 1. CHECK GROUND CIRCUIT

- Disconnect low tire pressure warning control unit connector M143.
- Check continuity between low tire pressure warning control unit connector M143 terminal 11 (B) and ground.

Terminals		Continuity
(+)	(-)	
Connector	Terminal (Wire color)	Ground  Yes
M143	11 (B)	

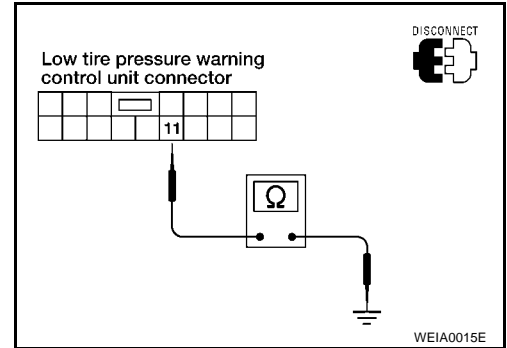

OK or NG

- OK >> GO TO 2.
- NG >> Repair or replace low tire pressure warning control unit ground circuit.

#### 2. CHECK RELAY

- Check low tire pressure warning relay. Refer to [WT-22, "Electrical Components Inspection"](#).

OK or NG

- OK >> Replace low tire pressure warning control unit.
- NG >> Replace low tire pressure warning relay.

## Inspection 5: ID Registration Cannot Be Completed

EES000LW

### DIAGNOSTIC PROCEDURE

#### 1. ID REGISTRATION (ALL)

- Carry out ID registration of all transmitters.
- Can ID registration of all transmitters be completed?

Yes or No?

- Yes >> **INSPECTION END**
- No >> GO TO [WT-17, "Inspection 1: Transmitter or Low Tire Pressure Warning Control Unit"](#).

# TROUBLE DIAGNOSIS FOR SYMPTOMS

## Electrical Components Inspection LOW TIRE PRESSURE WARNING RELAY

EES000MM

Check continuity between terminals 3 and 5, 6 and 7.

Condition	Continuity
12V direct current supply between terminals 1 and 2	Yes
No current supply	No

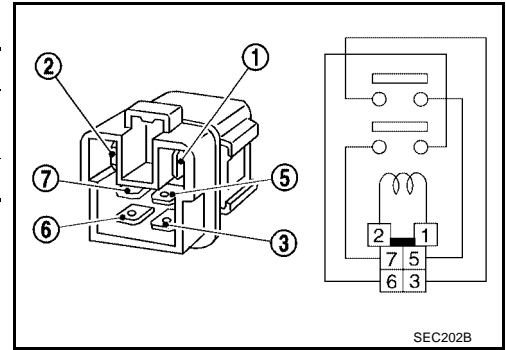

# REMOVAL AND INSTALLATION

PFP:00000

EES000LX

## REMOVAL AND INSTALLATION

### Transmitter (Pressure Sensor) REMOVAL

1. Deflate tire. Unscrew transmitter retaining nut and allow transmitter to fall into tire.
2. Gently bounce tire so that transmitter falls to bottom of tire. Place wheel and tire assembly on tire changing machine and break both tire beads. Ensure that the transmitter remains at the bottom of the tire while breaking the bead.

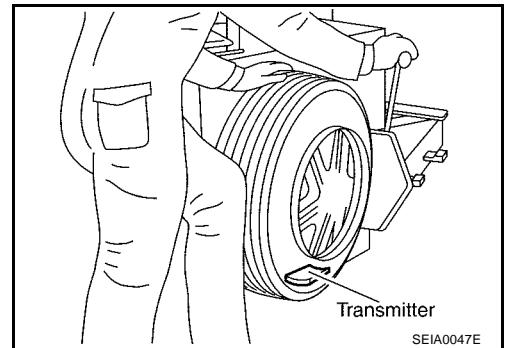

3. Turn tire so that valve hole is at bottom, and gently bounce the tire to ensure transmitter is near valve hole. Carefully lift tire onto turntable and position valve hole (and transmitter) 270 degrees from mounting/dismounting head.
4. Lubricate tire well, and remove top side of tire. Reach inside the tire and remove the transmitter.

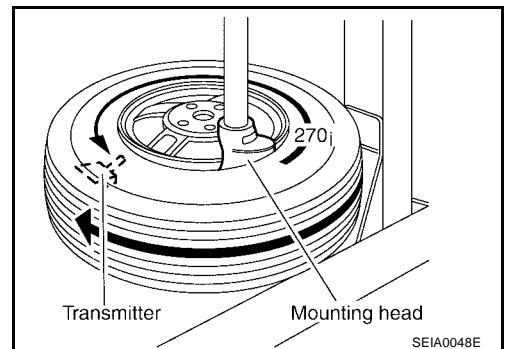

### INSTALLATION

1. Place first side of tire onto rim.

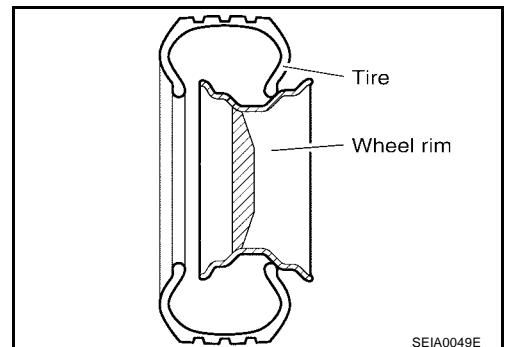

2. Mount transmitter on rim and tighten nut.

**Transmitter nut  
tightening torque : 4.1 - 6.8 N·m (0.42 - 0.69 kg·m,  
36 - 60 in·lb)**

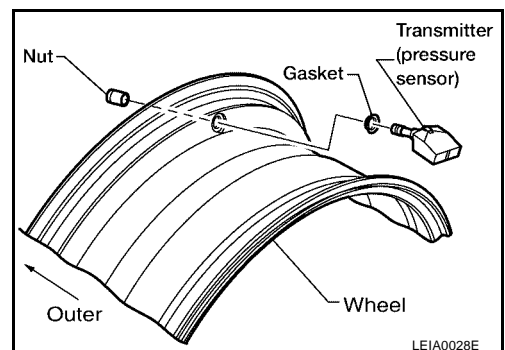

A  
B  
C  
D  
WT  
F  
G  
H  
I  
J  
K  
L  
M

## REMOVAL AND INSTALLATION

- Place wheel on turntable of tire machine. Ensure that transmitter is 270 degrees from mounting/dismounting head.

**NOTE:**

Do not touch transmitter with mounting head.

- Lubricate tire well, and install second side of tire as normal. Ensure that tire does not rotate relative to rim.
- Inflate tire and install in appropriate wheel position on vehicle.
- Adjust neutral position of steering angle sensor. Refer to [BRC-55, "Adjustment of Steering Angle Sensor Neutral Position"](#).

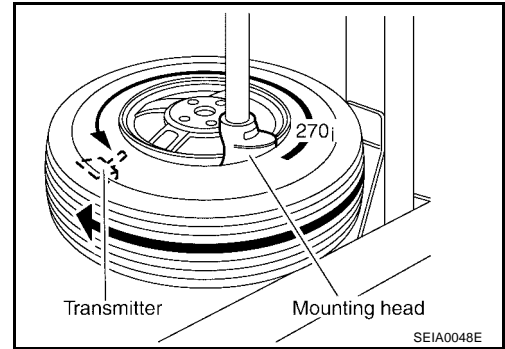



# SERVICE DATA AND SPECIFICATIONS (SDS)

## SERVICE DATA AND SPECIFICATIONS (SDS)

PF0:00030

### Road Wheel

EES000LY

Wheel type		Aluminum	Steel	
			Inside	Outside
Maximum radial runout limit	Lateral mm (in)	0.3 (0.012) or less	1.0 (0.039) or less	0.9 (0.035) or less
	Radial mm (in)	0.3 (0.012) or less	0.8 (0.031) or less	0.4 (0.016) or less
Allowable quantity of residual imbalance	Dynamic (at rim flange)	Less than 10 g (0.35 oz) (per side)		
	Static (at rim flange)	Less than 20 g (0.71 oz)		

### Tire

EES000LZ

Unit: kPa (kg/cm<sup>2</sup>, psi)

Tire size	Air pressure
P265/70R15	240 (2.4, 35)
P265/70R16	
P265/65R17	

A  
B  
C  
D  
WT  
F  
G  
H  
I  
J  
K  
L  
M

## SERVICE DATA AND SPECIFICATIONS (SDS)

---