

SECTION **FAX**
FRONT AXLE

A
B
C

FAX

CONTENTS

E

PRECAUTIONS	2	Removal	17	F
Precautions	2	Inspection	18	
PREPARATION	3	KNUCKLE SPINDLE	18	
Special Service Tools	3	BEARING SPACER (2WD MODELS)	18	G
Commercial Service Tools	3	NEEDLE BEARING (4WD MODELS)	18	
NOISE VIBRATION AND HARSHNESS (NVH)		Installation	18	
TROUBLESHOOTING	4	DRIVE SHAFT	20	H
NVH Troubleshooting Chart	4	Components	20	
ON-VEHICLE SERVICE	5	Removal	20	
Front Axle Parts	5	Disassembly	21	
Front Wheel Bearing	5	FINAL DRIVE SIDE (TS82F)	21	I
PRELOAD ADJUSTMENT (2WD MODELS)	5	WHEEL SIDE (ZF100)	22	
PRELOAD ADJUSTMENT (4WD MODELS)	6	Inspection	22	
Drive Shaft	8	DRIVE SHAFT	22	J
AUTO-LOCK FREE-RUNNING HUB	9	BOOT	22	
Description	9	JOINT ASSEMBLY (FINAL DRIVE SIDE)	22	
Removal and Installation	9	JOINT ASSEMBLY (WHEEL SIDE)	22	K
Inspection	10	Assembly	23	
Trouble Diagnosis For Noise	10	FINAL DRIVE SIDE (TS82F)	23	
WHEEL HUB AND ROTOR DISC	12	WHEEL SIDE (ZF100)	24	L
Components	12	Installation	25	
Removal and Installation	14	SERVICE DATA AND SPECIFICATIONS (SDS)	27	
Disassembly	15	Wheel Bearing (Front)	27	
Inspection	15	2WD MODELS	27	M
WHEEL BEARINGS	15	4WD MODELS	27	
WHEEL HUB	15	Drive Shaft (4WD models)	27	
Assembly	15	DRIVE SHAFT AXIAL END PLAY	27	
KNUCKLE SPINDLE	17	DRIVE SHAFT END SNAP RING	28	

PRECAUTIONS

PRECAUTIONS

PFP:00001

Precautions

EDS000P1

- When installing rubber parts, final tightening must be carried out under unladen condition* with tires on ground.
*: Fuel, radiator coolant and engine oil full. Spare tire, jack, hand tools and mats in designated positions.
- Use flare nut wrench when removing and installing brake tubes.
- After installing removed suspension parts, check wheel alignment and adjust if necessary.
- Always torque brake lines when installing.

CAUTION:

- The ZF100 (wheel side) type joint assembly has two types of boot material; one is made of rubber and the other is made of plastic.
- Do not disassemble the joint assembly with the plastic boot. If the boot or joint is damaged, replace the drive shaft assembly.

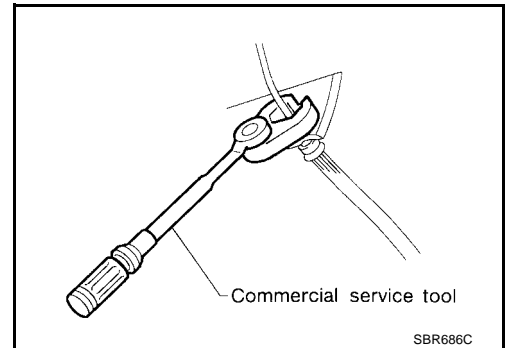

PREPARATION

PREPARATION

PFP:00002

Special Service Tools

EDS000P2

The actual shapes of Kent-Moore tools may differ from those of special service tools illustrated here.

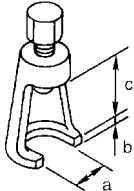
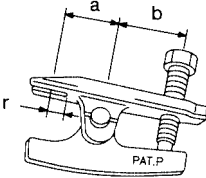
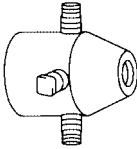
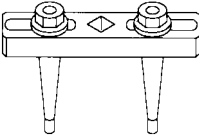
Tool number (Kent-Moore No.) Tool name	Description
ST29020001 (J24319-01) Gear arm puller	 Removing ball joint for knuckle spindle a: 34 mm (1.34 in) b: 6.5 mm (0.256 in) c: 61.5 mm (2.421 in)
HT72520000 (J25730-B) Ball joint remover	 Removing tie-rod outer end and lower ball joint a: 33 mm (1.30 in) b: 50 mm (1.97 in) r: R11.5 mm (0.453 in)
KV401021S0 (—) Bearing race drift	 Installing wheel bearing outer race
KV40105400 (J36001) Wheel bearing lock nut wrench	 Removing and installing wheel bearing lock nut (4WD models only)

Commercial Service Tools

EDS000P3

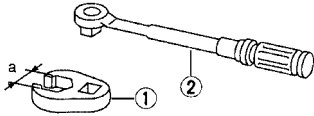
Tool name	Description
1 Flare nut crowfoot 2 Torque wrench	 Removing and installing each brake piping a: 10 mm (0.39 in)

NOISE VIBRATION AND HARSHNESS (NVH) TROUBLESHOOTING

NOISE VIBRATION AND HARSHNESS (NVH) TROUBLESHOOTING

PF5:54000

NVH Troubleshooting Chart

EDS000P4

Use the chart below to help you find the cause of the symptom. If necessary, repair or replace these parts.

Symptom		DRIVE SHAFT		Possible cause and SUSPECTED PARTS														
		Noise, Vibration	Shake	Excessive joint angle	Joint sliding resistance	Imbalance	Improper installation, looseness	Parts interference	Wheel bearing damage	PROPELLER SHAFT	DIFFERENTIAL	DRIVE SHAFT	AXLE	SUSPENSION	TIRES	ROAD WHEEL	BRAKES	STEERING
Symptom	DRIVE SHAFT	Noise, Vibration	x	x						x	x		x	x	x	x	x	x
		Shake	x		x					x			x	x	x	x	x	x
	AXLE	Noise				x	x			x	x	x		x	x	x	x	x
		Shake				x	x			x		x		x	x	x	x	x
		Vibration				x	x			x		x		x	x			x
		Shimmy				x	x							x	x	x	x	x
		Judder				x								x	x	x	x	x
Poor quality ride or handling				x	x	x						x	x	x				

x: Applicable

ON-VEHICLE SERVICE

PFP:00000

Front Axle Parts

EDS000P5

Check front axle parts for excessive play, cracks, wear and other damage.

- Shake each front wheel to check for excessive play. If looseness is noted, adjust wheel bearing end play, then check ball joint end play.
- Make sure that the cotter pin is inserted.
- Retighten all nuts and bolts to the specified torque. Refer to [FAX-12, "Components"](#) .

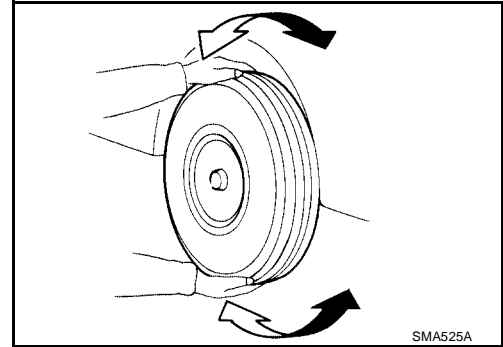

Front Wheel Bearing

EDS000P6

- Check that wheel bearings operate smoothly.
- Check axial end play.

Axial end play : 0 mm (0 in)

- Adjust wheel bearing preload if there is any axial end play or wheel bearing does not turn smoothly.

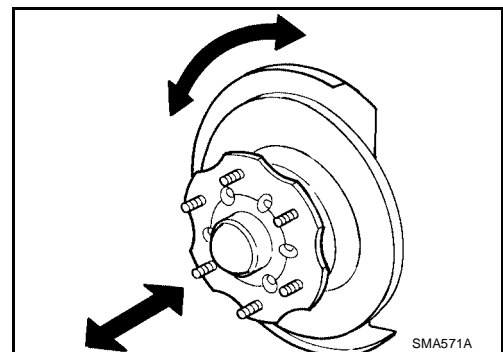

PRELOAD ADJUSTMENT (2WD MODELS)

Adjust wheel bearing preload after wheel bearing has been replaced or front axle has been reassembled.

1. Before adjustment, thoroughly clean all parts to prevent dirt entry.
2. Apply multi-purpose grease sparingly to the following parts:
 - Threaded area of spindle
 - Contact surface between lock washer and outer wheel bearing
 - Grease seal lip
 - Hub Cap

Hub cap grease: 18-22 g (0.63 - 0.78 oz)

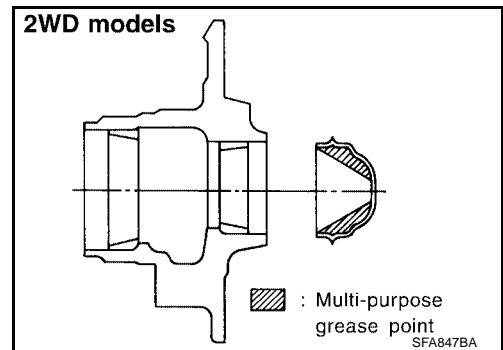

3. Tighten wheel bearing lock nut to the specified torque.

Tightening torque : 34 - 39 N·m (3.5 - 4.0 kg-m, 25 - 29 ft-lb)

4. Turn wheel hub several times in both directions to seat wheel bearing correctly.
5. Again tighten wheel bearing lock nut to the specified torque.

Tightening torque : 34 - 39 N·m (3.5 - 4.0 kg-m, 25 - 29 ft-lb)

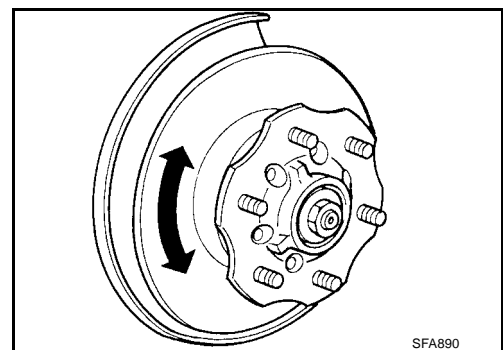

A
B
C
FAX
E
F
G
H
I
J
K
L
M

ON-VEHICLE SERVICE

6. Turn wheel bearing lock nut back 45 degrees.
7. Fit adjusting cap and new cotter pin. Align cotter pin slot by loosening nut 15 degrees or less.

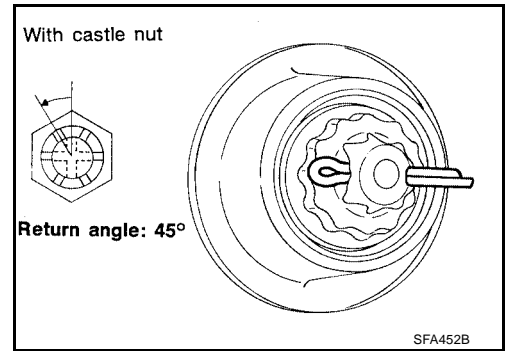

8. Measure wheel bearing preload and axial end play.

Axial end play : 0 mm (0 in)

Wheel bearing preload (As measured at wheel hub bolt)

New grease seal 9.8 - 28.4 N (1.0 - 2.9 kg, 2.2 - 6.4 lb)

Used grease seal 9.8 - 23.5 N (1.0 - 2.4 kg, 2.2 - 5.3 lb)

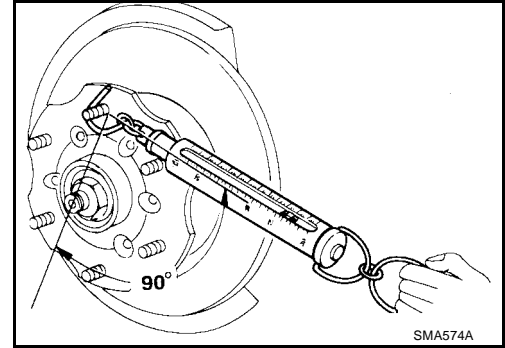

Repeat above procedures until correct bearing preload is obtained.

9. Spread cotter pin.
10. Install hub cap.

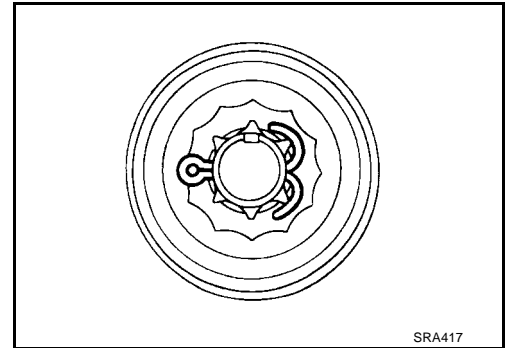

PRELOAD ADJUSTMENT (4WD MODELS)

Adjust wheel bearing preload after wheel bearing has been replaced or front axle has been reassembled.

Adjust wheel bearing preload as follows:

1. Before adjustment, thoroughly clean all parts to prevent dirt entry.
2. Apply multi-purpose grease sparingly to the following parts:
 - Threaded portion of spindle
 - Contact surface between wheel bearing washer and outer wheel bearing
 - Grease seal lip

Wheel hub grease :18-23 g (0.63- 0.81 oz)

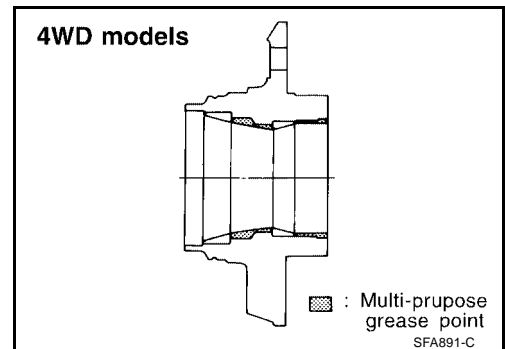

ON-VEHICLE SERVICE

3. Tighten wheel bearing lock nut with Tool.

Tightening torque : 78 - 98 N·m (8 - 10 kg·m, 58 - 72 ft·lb)

4. Turn wheel hub several times in both directions.
5. Loosen wheel bearing lock nut so that torque becomes 0 N·m (0 kg·m, 0 ft·lb).
6. Retighten wheel bearing lock nut with Tool.

Tightening torque : 0.5 - 1.5 N·m (0.05 - 0.15 kg·m, 4.3 - 13.0 in·lb)

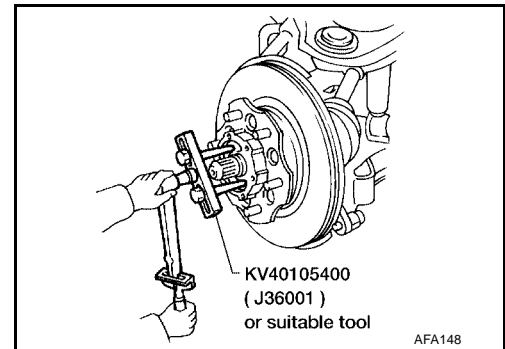

7. Turn wheel hub several times in both directions.
8. Retighten wheel bearing lock nut with Tool.

Tightening torque : 0.5 - 1.5 N·m (0.05 - 0.15 kg·m, 4.3 - 13.0 in·lb)

9. Measure wheel bearing axial end play.

Axial end play : 0 mm (0 in)

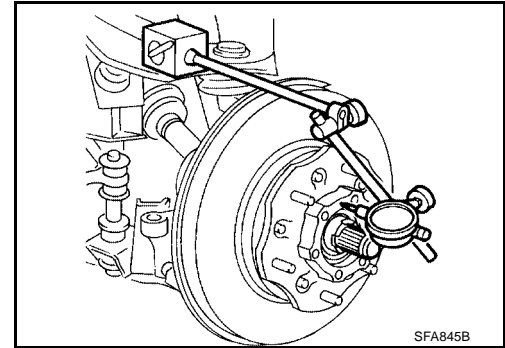

10. Measure starting force "A" at wheel hub bolt.

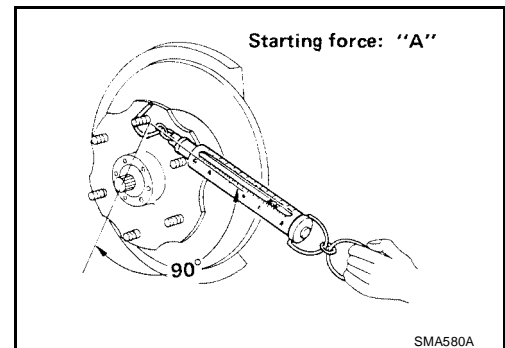

11. Install lock washer by tightening the lock nut within 15 to 30 degrees to align screw holes.
12. Turn wheel hub several times in both directions to seat wheel bearing correctly.
13. Measure starting force "B" at wheel hub bolt. Refer to step 10.
14. Wheel bearing preload "C" can be calculated as shown below.

$$C = B - A$$

Wheel bearing preload "C" : 7.06 - 20.99 N (0.72 - 2.14 kg, 1.59 - 4.72 lb)

15. If wheel bearing preload "C" is outside specifications, remove lock washer. Tighten or loosen lock nut within ± 15 degrees (Refer to step 11 above). Install lock washer, then repeat steps 12, 13 and 14.
16. Repeat above procedures until correct axial end play and wheel bearing preload are obtained.

A
B
C

FAX

E
F
G

H
I
J

K
L
M

ON-VEHICLE SERVICE

17. Tighten screws.

Tightening torque : 1.2 - 1.8 N·m (0.12 - 0.18 kg-m, 10.4 - 15.6 in-lb)

18. Install free-running hub.

19. Tighten bolts.

Tightening torque : 25 - 34 N·m (2.5 - 3.5 kg-m, 18 - 25 ft-lb)

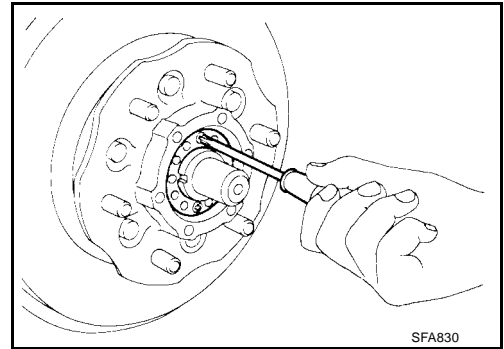

EDS000P7

Drive Shaft

- Check for grease leakage and damage.

CAUTION:

- The ZF100 (wheel side) type joint assembly has two types of boot material; one is made of rubber and the other is made of plastic.
- Do not disassemble the joint assembly with the plastic boot. If the boot or joint is damaged, replace the drive shaft assembly.

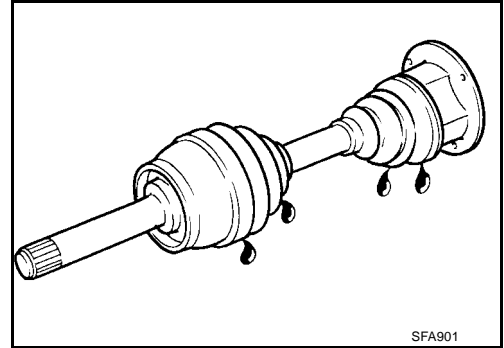

AUTO-LOCK FREE-RUNNING HUB

PFP:40260

AUTO-LOCK FREE-RUNNING HUB

EDS000PC

Description

Auto-lock free-running hubs are locked by placing the transfer case into the 4WD mode and moving the vehicle. They are unlocked by placing the transfer case into 2WD mode and moving the vehicle in reverse gear in a straight line for at least 2–3 meters (7–10 feet).

In most cases, the “ratcheting” noise sometimes heard in auto-lock free-running hubs occurs when one hub is locked and the opposite hub is unlocked. The noise is heard in the side opposite to the locked hub. For example, if the noise is heard at the left front wheel, the right front hub is still locked and is not unlocking. This condition may be caused by a mechanical condition in one of the hubs or by incorrect operation on the part of the vehicle driver, for example by not backing up in a straight line to unlock the hubs, by not backing up enough, or by shifting into 4WD at too high a vehicle speed, etc.

The ratcheting noise does not necessarily cause damage to the good hub. If the noise is caused by incorrect operation, counsel the driver of the vehicle. If replacement is necessary, replace only the defective parts. It is not necessary to replace auto-lock free-running hubs in pairs.

Use the trouble diagnosis chart to isolate the cause of the noise. Refer to [FAX-10, "Trouble Diagnosis For Noise"](#).

Removal and Installation

EDS000PD

SEC. 400

* : Lubricating parts

When installing auto-lock free-running hub, use NISSAN GENUINE GREASE (KRC 19-00025) or equivalent grease.

Auto-lock free-running hub assembly

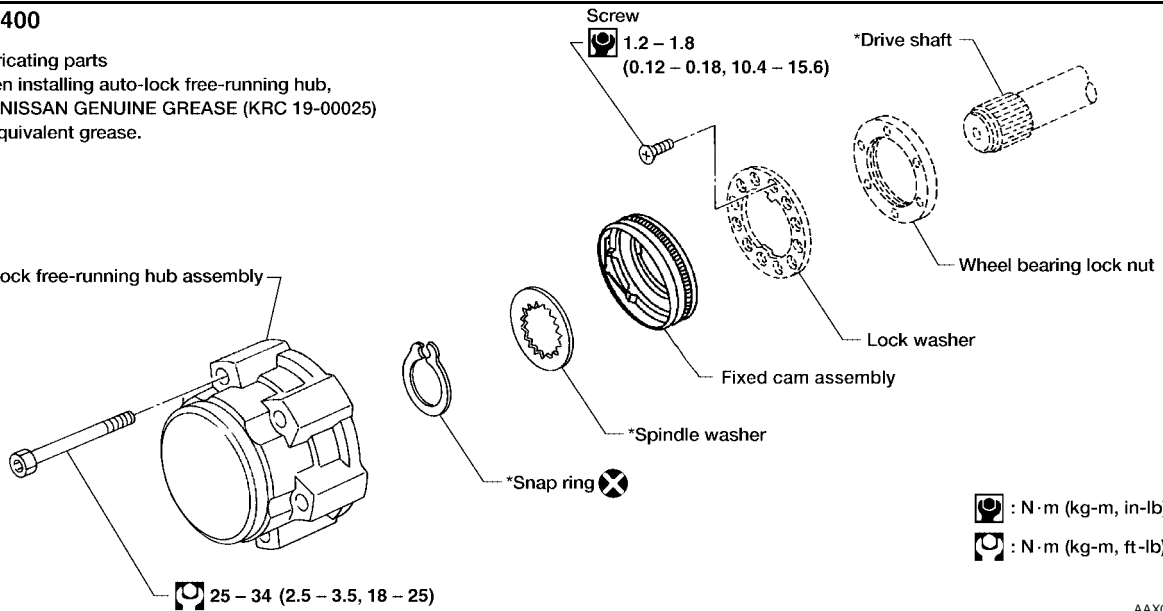

1. Remove auto-lock free-running hub assembly.

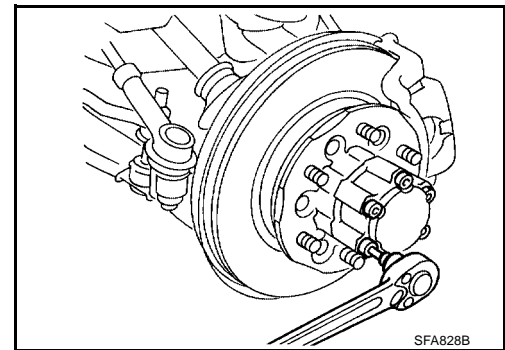

AUTO-LOCK FREE-RUNNING HUB

2. Remove snap ring.
3. Remove spindle washer and fixed cam assembly.
4. Install fixed cam assembly. Be sure to align the tabs of the fixed cam assembly to the notches of the knuckle.

NOTE:

During installation, apply recommended grease to the parts shown.

5. Place the spindle washer and then the snap ring over the axle shaft and position them between the 2 locking grooves.
6. While supporting the axle shaft behind the knuckle, use an appropriate sized deep socket to securely seat the snap ring into the inner locking groove.

CAUTION:

Visually verify that the snap ring is fully seated into the locking groove.

7. After installing auto-lock free-running hub, check operation.

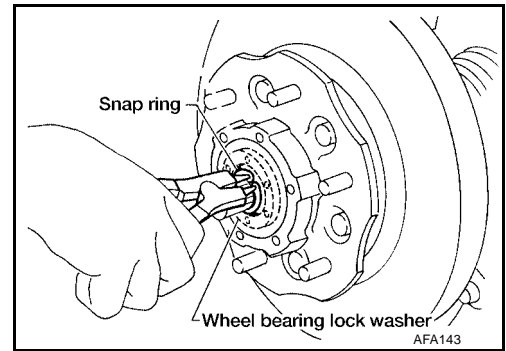

Inspection

EDS000PE

1. Check axle axial end play. Refer to [FAX-25, "Installation"](#).
2. Inspect fixed cam (thrust washer) assembly. If this part shows evidence of galling or heat damage—usually caused by too little axle axial end play—replace as necessary. Check axle axial end play if this part is replaced. Refer to [FAX-25, "Installation"](#).
3. Inspect hub assembly. Hold inner splines on a finger and spin the outer body. If the hub shows signs of damage, or if there is excessive metallic clicking when the hub is spun, replace with a new one.

NOTE:

New hubs are greased during manufacture. No additional grease is required.
New hubs are supplied with fixed cam assemblies.

CAUTION:

Any hub, the original or a new one, should go onto the axle freely by hand and fit flush against its seat. If it does not fit flush, do not pull the hub into place by tightening the bolts. The hub is possibly misaligned inside and tightening the bolts will cause damage. Remove the hub and turn to align correctly before continuing.

4. Once repair is complete, test drive to check for correct operation and the absence of noise.

Trouble Diagnosis For Noise

EDS000PF

Symptom	Possible cause	Repair order
Ratchet noise in hub after shifting the transfer case into 4WD at speeds higher than 40 km/h (25 mph).	Shifting into 4WD at higher speeds is difficult and may cause damage to transfer case	Stop the vehicle or decrease speed to less than 40 km/h (25 mph). Return the transfer case lever to the 2H position once, then re-shift to the 4H position. Move forward until the hubs lock.
Ratchet noise in hub after shifting or attempting to shift the transfer case into 4WD at speeds less than 40 km/h (25 mph).	Transfer case was not fully engaged or shifting was stopped halfway so that only one hub locked	Make sure the 4WD lamp on the dash is "ON" when shifting into 4WD. Slow or stop the vehicle. Shift into 2H, then back to 4H. Move forward until the hubs lock.
Ratchet noise in hub after shifting the transfer case into 4WD on snowy or muddy roads or on slopes.	If the rear wheels slip during the hub locking operation, noise can occur in the hubs	Reduce engine speed and drive forward slowly. The hubs will lock evenly and the noise will stop.
Ratchet noise in hub after shifting the transfer case into 2WD and backing up to unlock the hubs.	The hubs may not be fully released	Stop the vehicle, make sure the transfer case lever is fully in the 2H position, then back up slowly in a straight line at least 2-3 meters (7-10 feet).

AUTO-LOCK FREE-RUNNING HUB

Symptom	Possible cause	Repair order
Ratchet noise in hub when driving in extremely cold weather.	The viscosity of differential oil grows higher in extreme cold, increasing the possibility that one hub may lock. A lower viscosity differential fluid may be required for extreme cold temperatures. See owner's manual	Shift the transfer case into 4H and drive the vehicle for 10 minutes or more to warm the differential oil. Then shift to 2WD and back up in a straight line for at least 2-3 meters (7-10 feet) to disengage the hubs.
Continual ratchet noise in one wheel when moving forward.	A hub may be mechanically locked either by damage or incorrect installation	Remove hubs and inspect. Refer to FAX-18. "Inspection" . Pay special attention to the hub opposite the noisy side. The ratcheting does not necessarily cause damage to the good hub.

A

B

C

FAX

E

F

G

H

I

J

K

L

M

WHEEL HUB AND ROTOR DISC

PFP:40202

EDS000P8

WHEEL HUB AND ROTOR DISC

Components

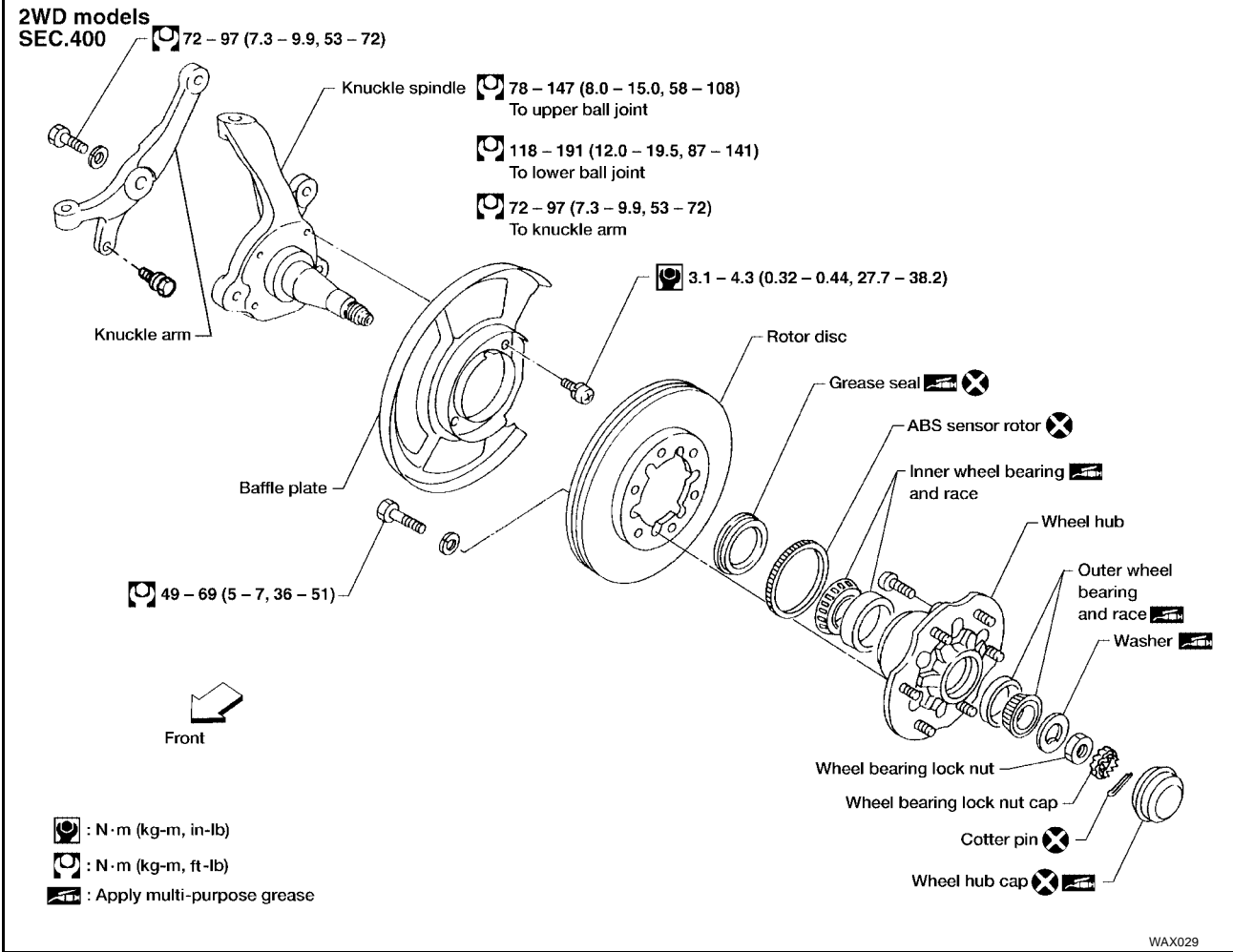

WAX029

WHEEL HUB AND ROTOR DISC

4WD models
SEC. 391 • 400

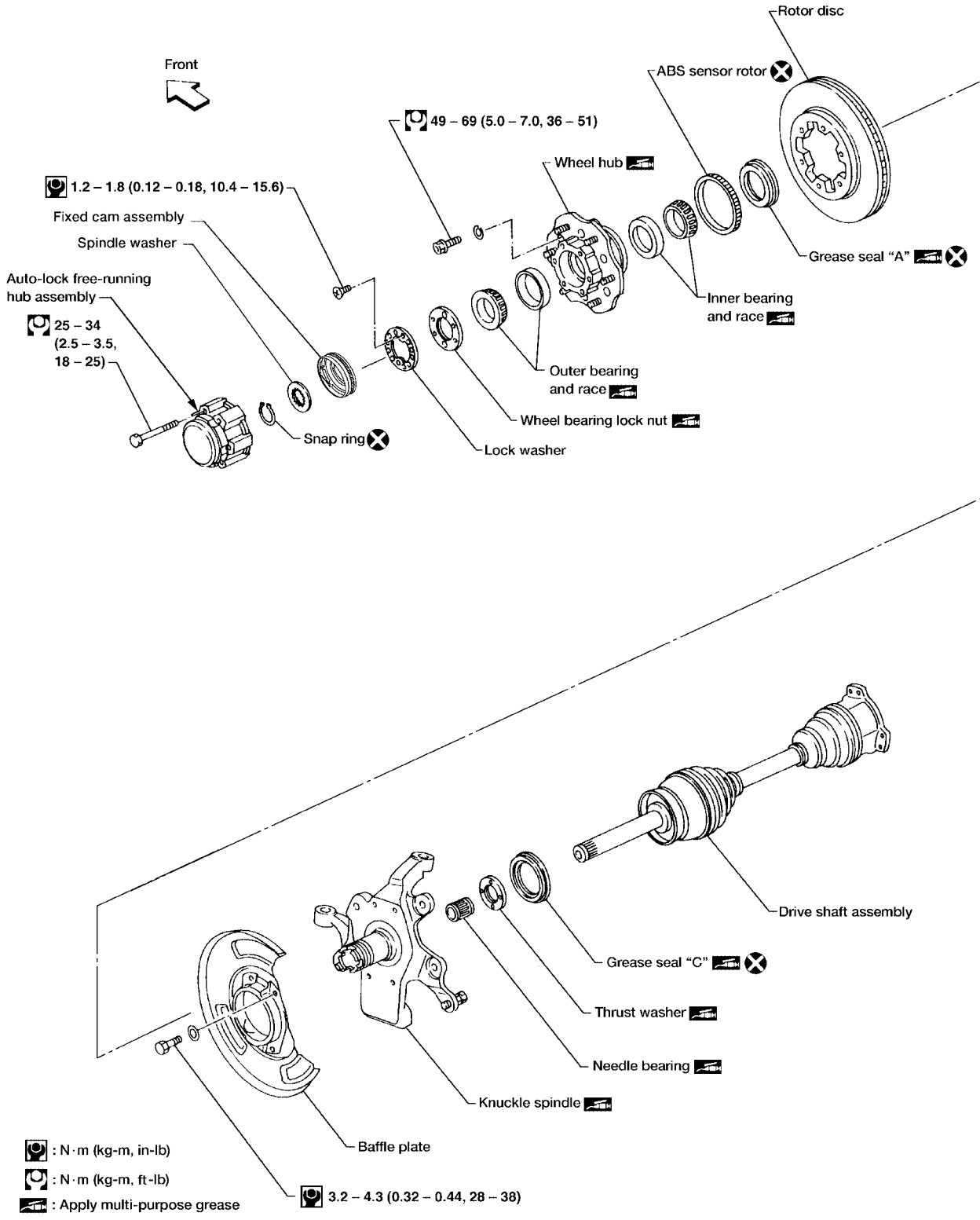

A
B
C
FAX
E
F
G
H
I
J
K
L
M

WAX026

WHEEL HUB AND ROTOR DISC

EDS000PG

Removal and Installation

CAUTION:

If equipped with ABS, disconnect the ABS wheel sensor from the assembly before removing the front axle assembly. Then move it away from the front axle assembly area. Failure to do so may result in damage to the sensor wires and the sensor becoming inoperative.

1. Remove free-running hub assembly (4WD models).
Refer to [FAX-9, "AUTO-LOCK FREE-RUNNING HUB"](#) .
2. Remove brake caliper assembly without disconnecting hydraulic line.

NOTE:

- Brake hose need not be disconnected from brake caliper. In this case, suspend caliper assembly with wire so as not to stretch brake hose.
- Be careful not to depress brake pedal, or piston will pop out.
- Make sure brake hose is not twisted.

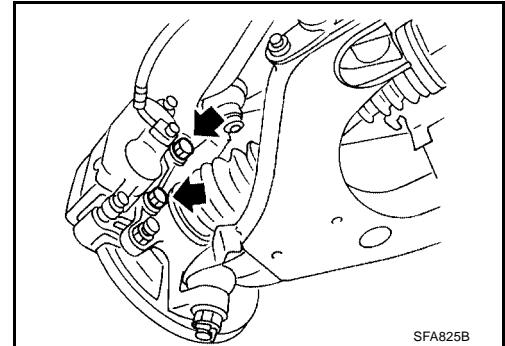

3. Remove lock washer (4WD models).

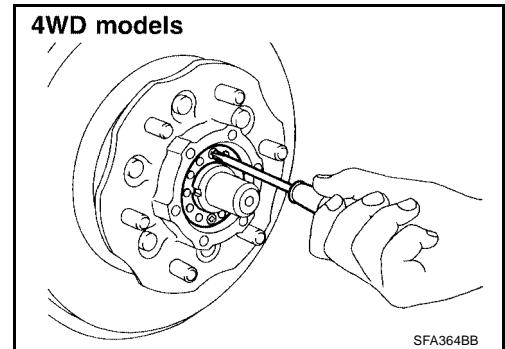

4. Remove wheel bearing lock nut.
 - 2WD Models: With suitable tool
 - 4WD Models: With Tool

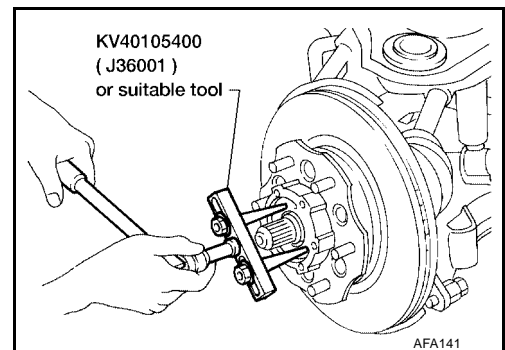

5. Remove wheel hub and wheel bearing.

CAUTION:

Be careful not to drop outer bearing.

6. After installing wheel hub and wheel bearing, adjust wheel bearing preload. Refer to [FAX-5, "PRELOAD ADJUSTMENT \(2WD MODELS\)"](#) ; or [FAX-6, "PRELOAD ADJUSTMENT \(4WD MODELS\)"](#) .

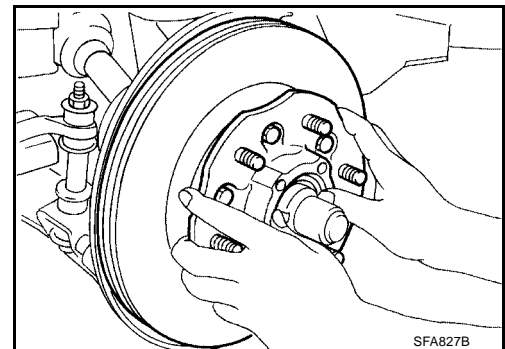

WHEEL HUB AND ROTOR DISC

Disassembly

EDS000PH

- Remove grease seal and bearing outer races with suitable brass bar.

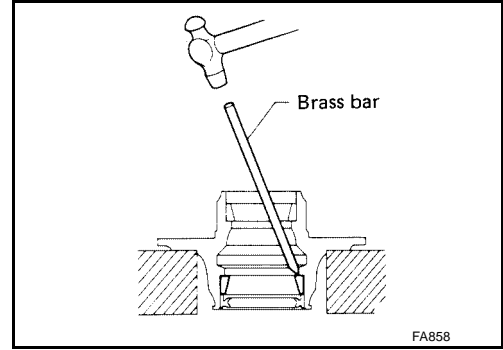

A
B
C

FAX

Inspection

Thoroughly clean wheel bearings and wheel hub.

WHEEL BEARINGS

- Make sure wheel bearings roll freely and are free from noise, cracks, pitting and wear.

WHEEL HUB

- Check wheel hub for cracks by using a magnetic exploration or dyeing test.

Assembly

EDS000PJ

1. Install bearing outer race with Tool until it is fully seated in hub.

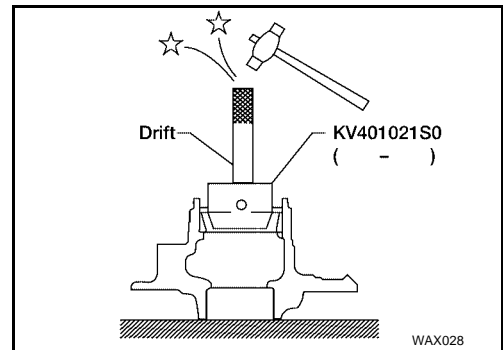

H
I
J

2. Install the sensor rotor using suitable drift and press.

- Always replace sensor rotor with new one.
- Pay attention to the direction of front sensor rotor as shown in figure.

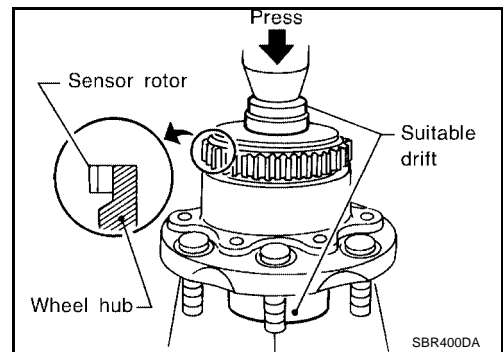

K
L
M

3. Pack multi-purpose grease in wheel hub and hub cap (2WD models).

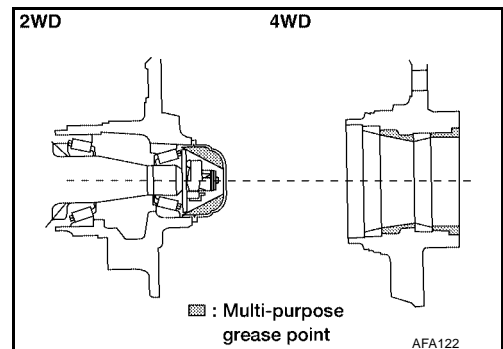

WHEEL HUB AND ROTOR DISC

4. Apply multi-purpose grease to each bearing cone.
5. Pack grease seal lip with multi-purpose grease, then install it into wheel hub with suitable drift.

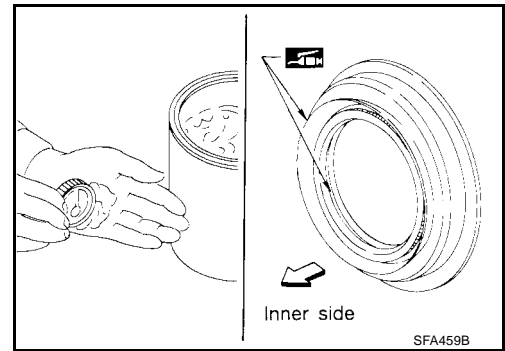

KNUCKLE SPINDLE

PFP:40014

KNUCKLE SPINDLE

EDS000PK

Removal

1. Remove free-running hub assembly (4WD models).
Refer to [FAX-9, "AUTO-LOCK FREE-RUNNING HUB"](#) .
2. Remove wheel hub and rotor disc.
Refer to [FAX-14, "Removal and Installation"](#) .

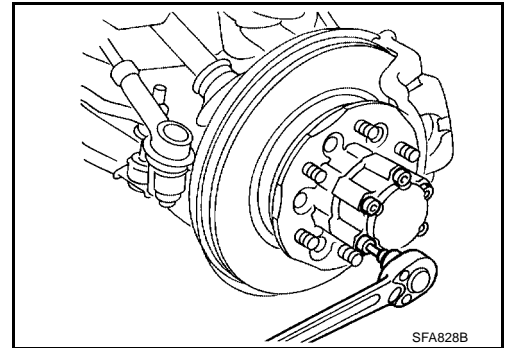

3. Separate drive shaft from knuckle spindle by slightly tapping drive shaft end (4WD models).

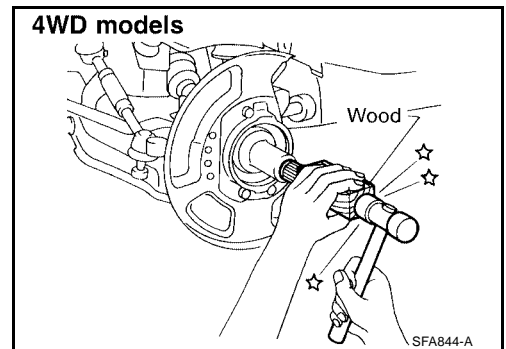

4. Separate tie-rod from knuckle spindle with Tool.
CAUTION:
Install stud nut conversely on stud bolt so as not to damage stud bolt.

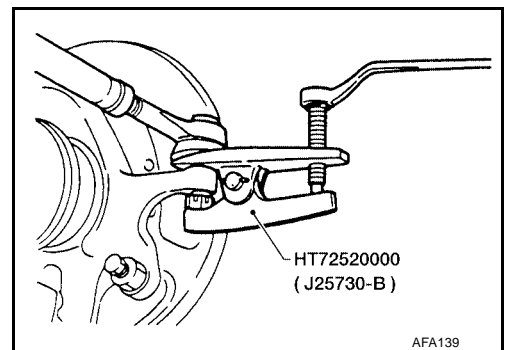

5. Separate knuckle spindle from ball joints.
 - a. Loosen (do not remove) upper and lower ball joint tightening nuts.

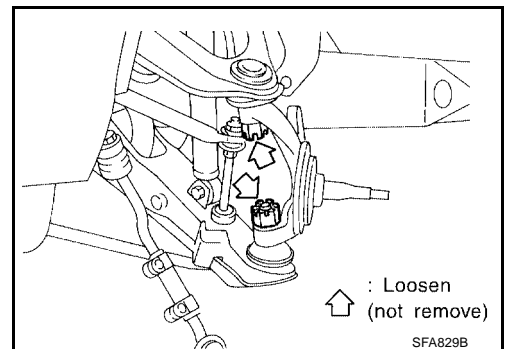

A
B
C
FAX
E
F
G
H
I
J
K
L
M

KNUCKLE SPINDLE

- b. Separate knuckle spindle from upper and lower ball joint studs with Tool.

CAUTION:

During above operation, never remove ball joint nuts which are loosened in step (a) above.

Tool

2WD Models : ST29020001 (J24319-01)

4WD Models : HT72520000 (J25730-B)

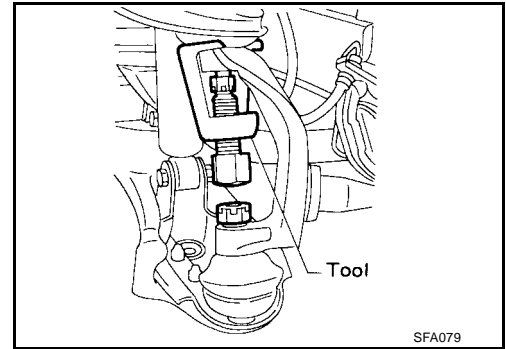

- c. Remove ball joint tightening nuts.

CAUTION:

Support lower link with jack.

- d. Remove knuckle spindle from upper and lower links.

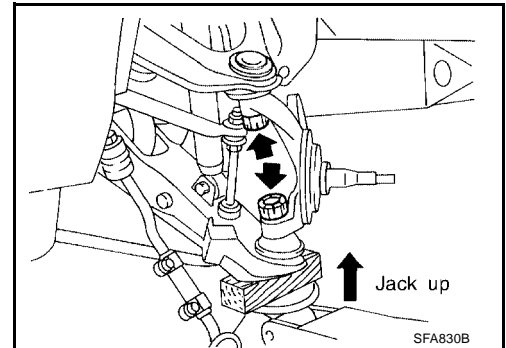

Inspection KNUCKLE SPINDLE

EDS000PL

- Check knuckle spindle for deformation, cracks and other damage by using a magnetic exploration or dyeing test.

BEARING SPACER (2WD MODELS)

- Check bearing spacer for damage.

NEEDLE BEARING (4WD MODELS)

- Check needle bearing for wear, scratches, pitting, flaking and burn marks.

Installation

EDS000PM

1. Install needle bearing into knuckle spindle (4WD models).

CAUTION:

Make sure that needle bearing is facing in the proper direction.

2. Apply multi-purpose grease.

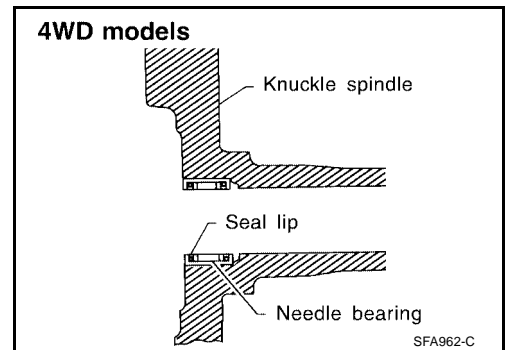

3. Install knuckle spindle to upper and lower ball joints with lower link jacked up.

CAUTION:

Make sure that oil and grease do not come into contact with tapered areas of ball joint, knuckle spindle and threads of ball joint.

4. Connect tie-rod to knuckle spindle.
5. Install wheel hub and rotor disc. Refer to [FAX-14, "Removal and Installation"](#).

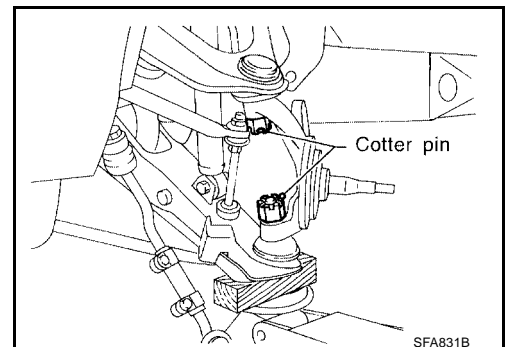

KNUCKLE SPINDLE

6. After installing knuckle spindle, adjust wheel bearing preload. Refer to [FAX-5, "PRELOAD ADJUSTMENT \(2WD MODELS\)"](#) ; or [FAX-6, "PRELOAD ADJUSTMENT \(4WD MODELS\)"](#) .
7. After installing drive shaft, check drive shaft axial end play. Refer to [FAX-25, "Installation"](#) .
 - Do not reuse snap ring once it has been removed.
8. Install free-running hub assembly (4WD models). Refer to [FAX-14, "Removal and Installation"](#) .

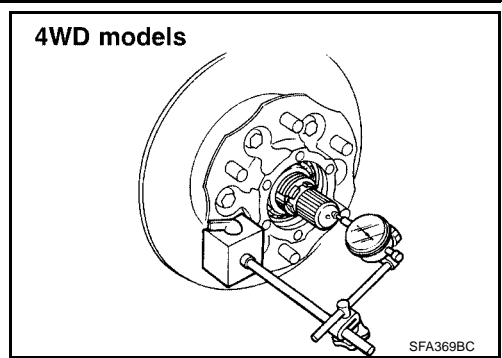

A
B
C

FAX

E
F
G
H
I
J
K
L
M

DRIVE SHAFT

DRIVE SHAFT

PFP:39100

Components

EDS000PN

CAUTION:

- The ZF100 (wheel side) type joint assembly has two types of boot material; one is made of rubber and the other is made of plastic.
- Do not disassemble the joint assembly with the plastic boot. If the boot or joint is damaged, replace the drive shaft assembly.

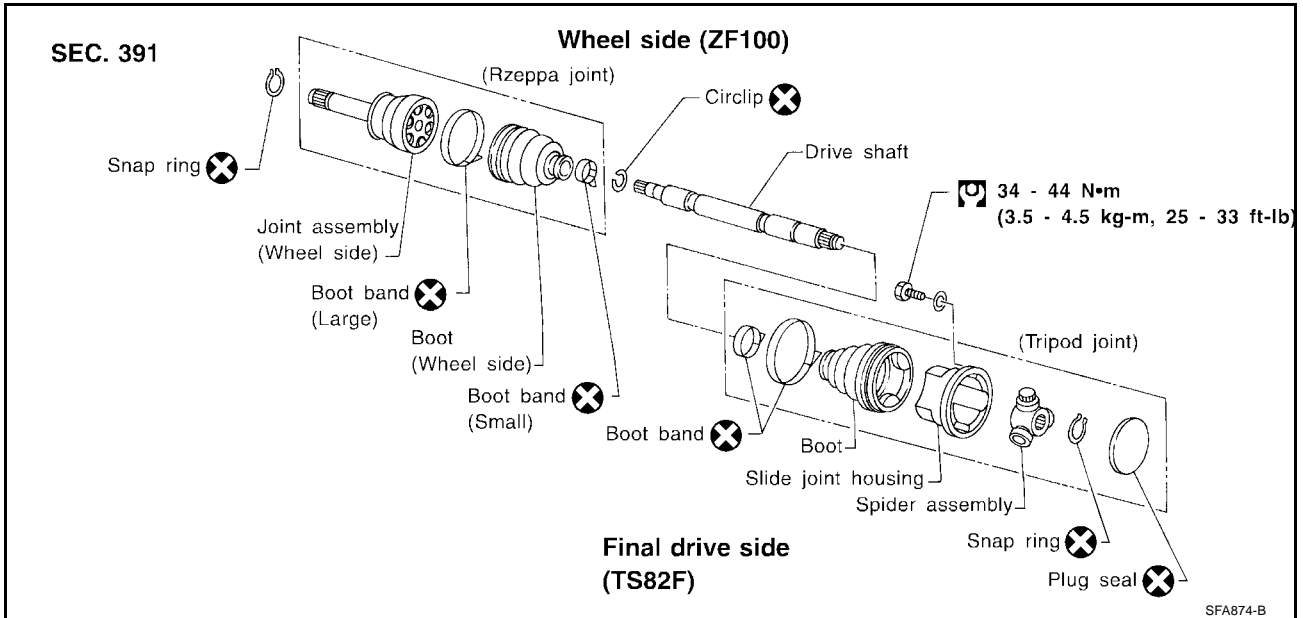

Removal

EDS000PO

1. Remove free-running hub or drive flange and snap ring. Refer to [FAX-9, "Removal and Installation"](#).
2. Remove torsion bar spring. Refer to [FSU-14, "Removal"](#).
3. Remove shock absorber lower bolt.
4. Remove lower link bolts.

CAUTION:

Support lower link with jack.

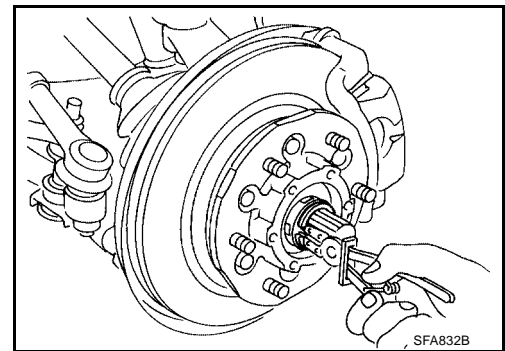

5. Remove drive shaft to final drive bolts.

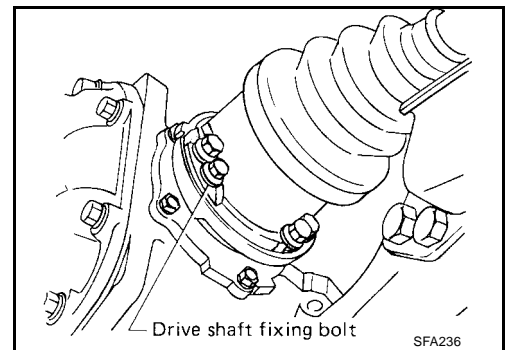

DRIVE SHAFT

6. Separate drive shaft from knuckle spindle by slightly tapping end of drive shaft.

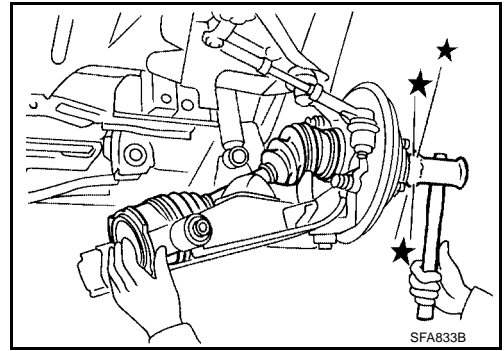

EDS000PP

Disassembly FINAL DRIVE SIDE (TS82F)

1. Remove plug seal from slide joint housing by lightly tapping around slide joint housing.
2. Remove boot bands.

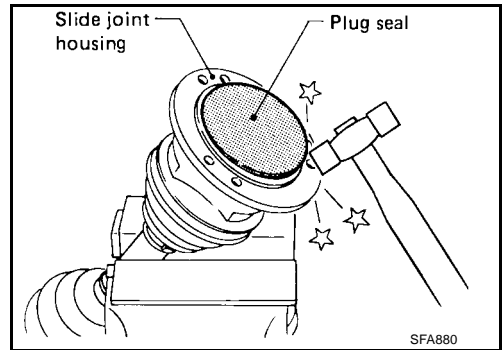

3. Move boot and slide joint housing toward wheel side, and apply matching marks.

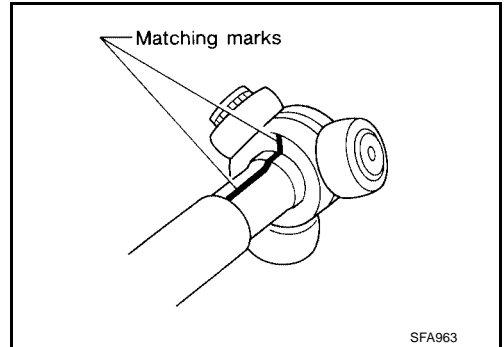

4. Remove snap ring.

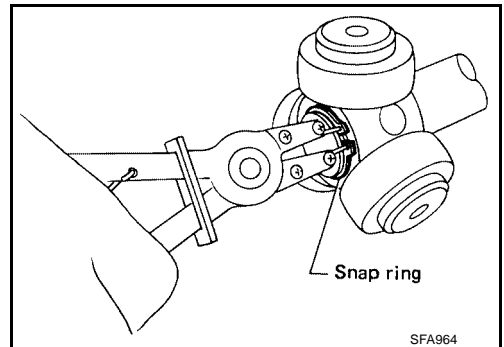

A
B
C
FAX

E
F
G
H

I
J
K
L

M

DRIVE SHAFT

5. Detach spider assembly with press.

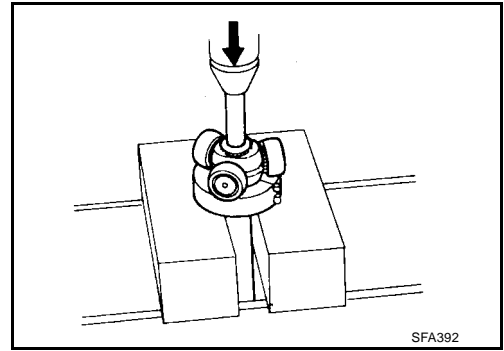

6. Draw out boot.

CAUTION:

Cover drive shaft serration with tape to prevent damaging the boot.

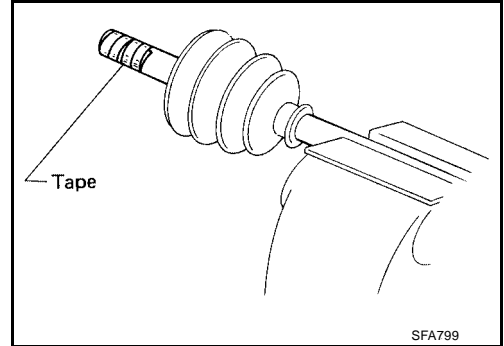

WHEEL SIDE (ZF100)

CAUTION:

- The ZF100 (wheel side) type joint assembly has two types of boot material; one is made of rubber and the other is made of plastic.
- Do not disassemble the joint assembly with the plastic boot. If the boot or joint is damaged, replace the drive shaft assembly.
- Be careful not to damage threads on drive shaft.

The procedures for the joint with the rubber boot are as follows:

- Before separating joint assembly, put matching marks on drive shaft and joint assembly.
- Separate joint assembly with suitable tool.
- Remove boot bands.

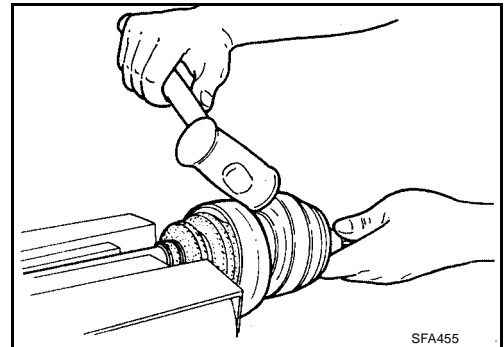

Inspection

Thoroughly clean all parts in cleaning solvent, and dry with compressed air. Check parts for evidence of deformation and other damage.

DRIVE SHAFT

Replace drive shaft if it is twisted, cracked or bent.

BOOT

Check boot for fatigue, cracks and wear. Replace boot and boot bands with new.

JOINT ASSEMBLY (FINAL DRIVE SIDE)

- Replace any parts of double offset joint which show signs of scorching, rust, wear or excessive play.
- Check serration for deformation. Replace if necessary.
- Check slide joint housing for any damage. Replace if necessary.

JOINT ASSEMBLY (WHEEL SIDE)

CAUTION:

- The ZF100 (wheel side) type joint assembly has two types of boot material; one is made of rubber and the other is made of plastic.

EDS000PQ

DRIVE SHAFT

- Do not disassemble the joint assembly with the plastic boot. If the boot or joint is damaged, replace the drive shaft assembly.

Replace joint assembly if it is deformed or damaged.

Assembly

EDS000PR

- After drive shaft has been assembled, ensure that it moves smoothly over its entire range without binding.
- Use Nissan Genuine Grease or equivalent after every overhaul.

FINAL DRIVE SIDE (TS82F)

1. Install new small boot band, boot and side joint housing to drive shaft.

CAUTION:

Cover drive shaft serration with tape to prevent damaging boot during installation.

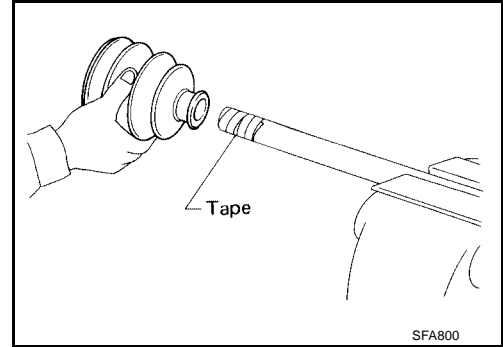

2. Install spider assembly securely, making sure marks are properly aligned.
 - Press-fit with spider assembly serration chamfer facing shaft.
3. Install new snap ring.

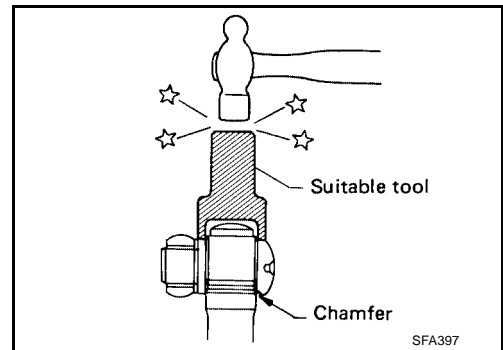

4. Pack with grease.

Specified amount of : 95 - 105 g (3.35 - 3.70 oz) grease

5. Make sure that the boot is properly installed on the drive shaft groove. Set the boot so that it does not swell or deform when its length is "L1".

Length "L1" : 95 - 97 mm (3.74 - 3.82 in)

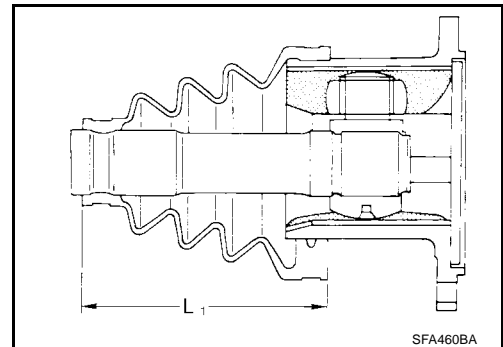

6. Lock new large boot band securely with a suitable tool, then lock new small boot band.
7. Install new plug seal to slide joint housing by lightly tapping it.
 - Apply suitable sealant to mating surface of plug seal.

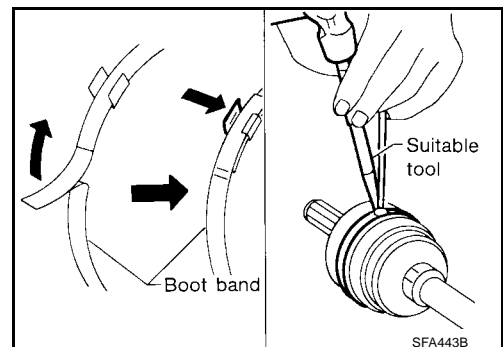

A

B

C

FAX

E

F

G

H

I

J

K

L

M

DRIVE SHAFT

WHEEL SIDE (ZF100)

CAUTION:

- The ZF100 (wheel side) type joint assembly has two types of boot material; one is made of rubber and the other is made of plastic.
- Do not disassemble the joint assembly with the plastic boot. If the boot or joint is damaged, replace the drive shaft assembly.

The procedures for the joint with the rubber boot are as follows:

1. Install new small boot band and boot on drive shaft.

CAUTION:

Cover drive shaft serration with tape to prevent damaging boot during installation.

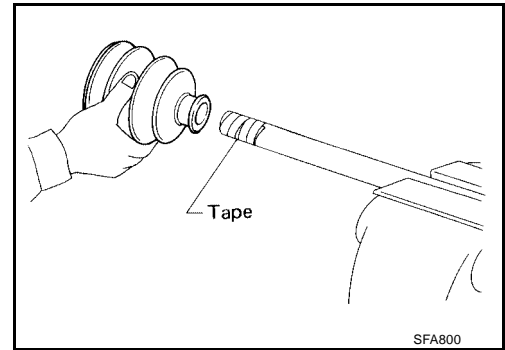

2. Set joint assembly onto drive shaft by lightly tapping it. Install joint assembly securely, ensuring that marks which were made during disassembly are properly aligned.

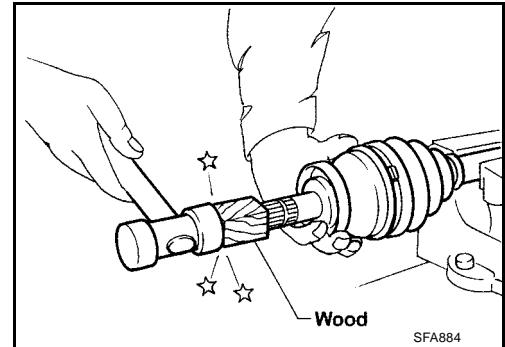

3. Pack drive shaft with specified amount of grease.

Specified amount of grease : 115 - 125 g (4.06 - 4.41 oz)

4. Make sure that the boot is properly installed on the drive shaft groove. Set the boot so that it does not swell or deform when its length is "L2".

Length "L2" : 96 - 98 mm (3.78 - 3.86 in)

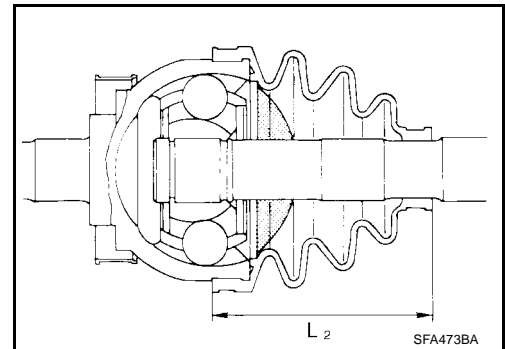

5. Lock new large boot band securely with a suitable tool, then lock new small boot band.

- Apply suitable sealant to mating surface of plug seal.

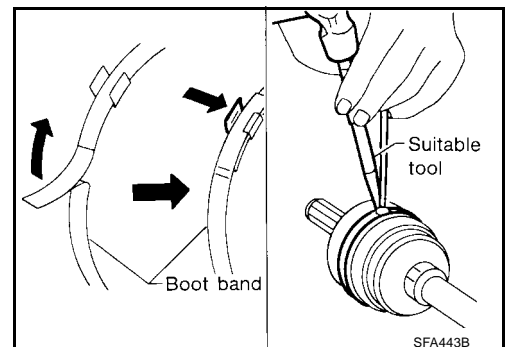

DRIVE SHAFT

EDS000PS

Installation

1. Apply multi-purpose grease.

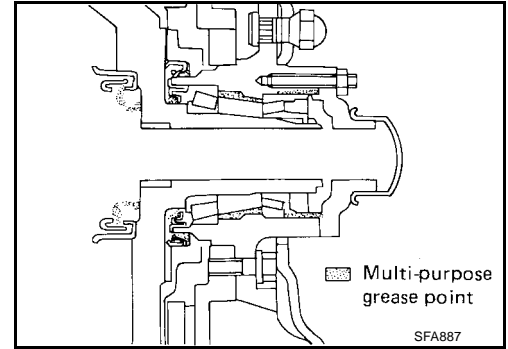

2. Install bearing spacer onto drive shaft.
Make sure that the bearing spacer is facing in the proper direction.
3. After installing wheel hub and wheel bearing, adjust wheel bearing preload. Refer to [FAX-5, "PRELOAD ADJUSTMENT \(2WD MODELS\)"](#) ; or [FAX-6, "PRELOAD ADJUSTMENT \(4WD MODELS\)"](#) .

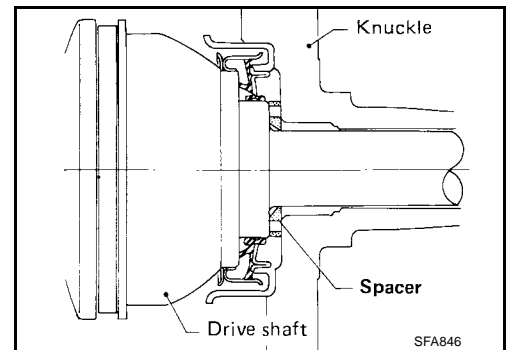

4. When installing drive shaft, adjust drive shaft axial end play by selecting a suitable snap ring.
 - a. Temporarily install new snap ring on drive shaft in the same thickness as the one that was removed.

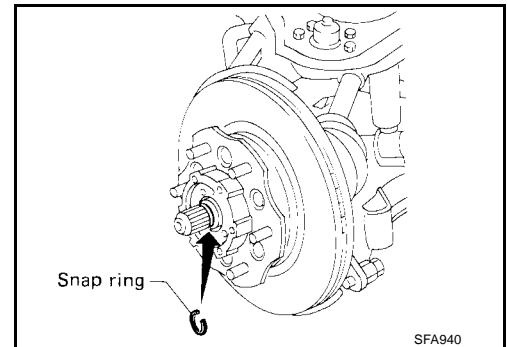

- b. Set dial gauge on drive shaft end.
- c. Measure axial end play of drive shaft.
Axial end play : 0.10 – 0.45 mm (0.004 – 0.0177 in)
- d. If axial end play is not within the specified limit, select another snap ring. Refer to [FAX-28, "DRIVE SHAFT END SNAP RING"](#) .

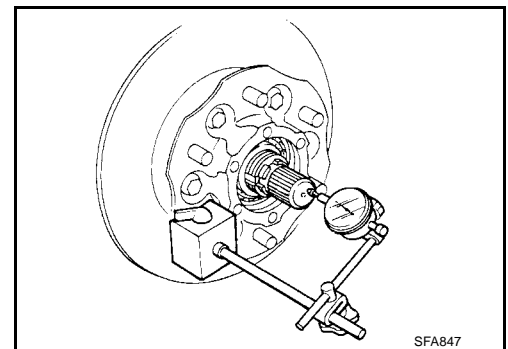

5. Install torsion bar spring. Refer to [FSU-15, "Installation and Adjustment"](#)

A
B
C
FAX
E
F
G
H
I
J
K
L
M

DRIVE SHAFT

6. Install auto-lock free-running hub or drive flange and snap ring.
Refer to [FAX-9, "Removal and Installation"](#).

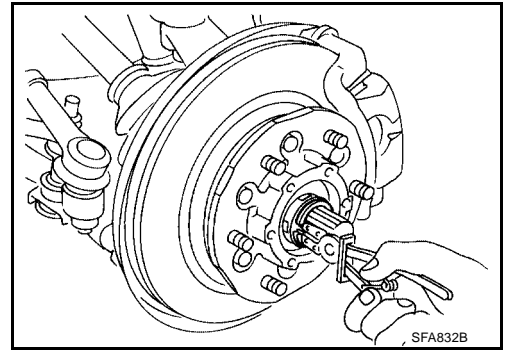

SERVICE DATA AND SPECIFICATIONS (SDS)

SERVICE DATA AND SPECIFICATIONS (SDS)

PF0:00030

Wheel Bearing (Front) 2WD MODELS

EDS000PT

Wheel bearing axial end play	mm (in)	0 (0)
Wheel bearing lock nut	Tightening torque	N·m(kg-m, ft-lb)
	Return angle	degree
Wheel bearing starting torque	At wheel hub bolt	
	With new grease seal	N (kg, lb)
	With used grease seal	N (kg, lb)

4WD MODELS

Wheel bearing lock nut	Tightening torque	N·m(kg-m, ft-lb)	78 - 98 (8 - 10, 58 - 72)
	Retightening torque after loosening wheel bearing lock nut	N·m(kg-m, in-lb)	0.5 - 1.5 (0.05 - 0.15, 4.3 - 13)
	Axial end play	mm (in)	0 (0)
	Starting force at wheel hub bolt	N (kg, lb)	A
	Turning angle	degree	15° - 30°
	Starting force at wheel hub bolt	N (kg, lb)	B
Wheel bearing preload at wheel hub bolt	N (kg, lb)	B - A	7.06 - 20.99 (0.72 - 2.14, 1.59 - 4.72)

Drive Shaft (4WD models)

EDS000PU

Drive shaft joint type	Final drive side	TS82F	
	Wheel side	ZF100*	
	Fixed joint axial end play limit	mm (in)	
Diameter	mm (in)	Wheel side (D ₁)	29.0 (1.142)
Grease	Quality	NISSAN genuine grease or equivalent	
	Capacity	g (oz)	Final drive side
			Wheel side
Boot length	mm (in)	Final drive side (L ₁)	95 - 97 (3.74 - 3.82)
		Wheel side (L ₂)	96 - 98 (3.78 - 3.86)

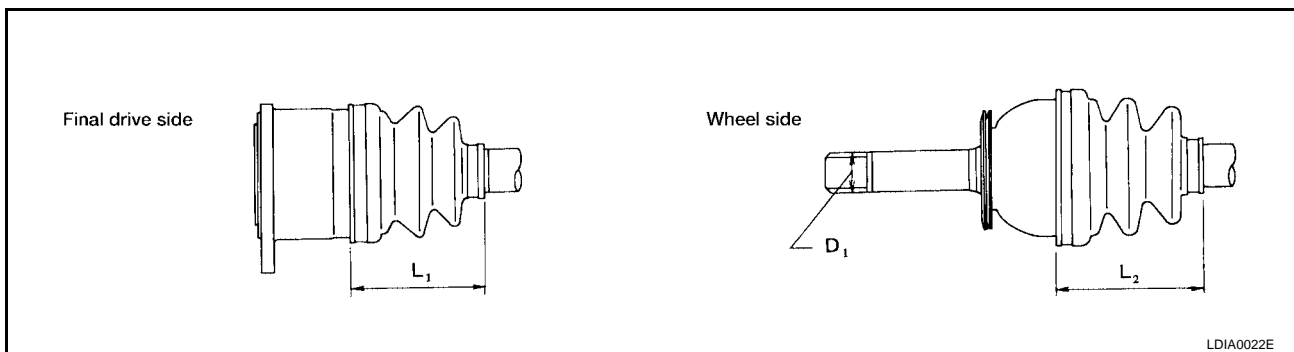

LDIA0022E

*: The ZF100 (wheel side) type joint assembly has two types of boot material; one is made of rubber and the other is made of plastic. Do not disassemble the joint assembly with the plastic boot. If the boot or joint is damaged, replace the drive shaft assembly.

DRIVE SHAFT AXIAL END PLAY

Drive shaft axial end play	mm (in)	0.10 - 0.45 (0.004 - 0.0177)
----------------------------	---------	------------------------------

SERVICE DATA AND SPECIFICATIONS (SDS)

DRIVE SHAFT END SNAP RING

Thickness mm (in)	Part No.*
1.1 (0.043)	39253-88G10
1.3 (0.051)	39253-88G11
1.5 (0.059)	39253-88G12
1.7 (0.067)	39253-88G13
1.9 (0.075)	39253-88G14
2.1 (0.083)	39253-88G15
2.3 (0.091)	39253-88G16

*: Always check with the Parts Department for the latest parts information.