

SECTION **PG**

**POWER SUPPLY, GROUND & CIRCUIT ELEMENTS**

**CONTENTS**

<b>SERVICE INFORMATION</b> .....	<b>2</b>	<b>GROUND CIRCUIT</b> .....	<b>29</b>	
<b>PRECAUTIONS</b> .....	<b>2</b>	Ground Distribution .....	29	
Precaution for Supplemental Restraint System (SRS) "AIR BAG" and "SEAT BELT PRE-TENSIONER" .....	2	<b>HARNESS</b> .....	<b>38</b>	
<b>POWER SUPPLY ROUTING CIRCUIT</b> .....	<b>3</b>	Harness Layout .....	38	
Schematic .....	3	Wiring Diagram Codes (Cell Codes) .....	57	
Wiring Diagram - POWER - .....	5	<b>ELECTRICAL UNITS LOCATION</b> .....	<b>60</b>	
Fuse .....	15	Electrical Units Location .....	60	
Fusible Link .....	15	<b>HARNESS CONNECTOR</b> .....	<b>64</b>	
Circuit Breaker (Built Into BCM) .....	15	Description .....	64	
Circuit Breaker .....	15	<b>ELECTRICAL UNITS</b> .....	<b>67</b>	
<b>IPDM E/R (INTELLIGENT POWER DISTRIBUTION MODULE ENGINE ROOM)</b> .....	<b>16</b>	Terminal Arrangement .....	67	
System Description .....	16	<b>STANDARDIZED RELAY</b> .....	<b>68</b>	
CAN Communication System Description .....	17	Description .....	68	
Function of Detecting Ignition Relay Malfunction ....	17	<b>SUPER MULTIPLE JUNCTION (SMJ)</b> .....	<b>70</b>	
CONSULT-III Function (IPDM E/R) .....	17	Terminal Arrangement .....	70	
Auto Active Test .....	19	<b>FUSE BLOCK-JUNCTION BOX (J/B)</b> .....	<b>72</b>	
IPDM E/R Terminal Arrangement - Type A .....	22	Terminal Arrangement .....	72	
IPDM E/R Terminal Arrangement - Type B .....	23	<b>FUSE AND FUSIBLE LINK BOX</b> .....	<b>73</b>	
Terminal and Reference Value for IPDM E/R .....	24	Terminal Arrangement .....	73	
IPDM E/R Power/Ground Circuit Inspection .....	26			
Inspection with CONSULT-III (Self-Diagnosis) .....	27			
Removal and Installation of IPDM E/R .....	27			

A  
B  
C  
D  
E  
F  
G  
H  
I  
J  
L  
M  
N  
O  
P



# PRECAUTIONS

< SERVICE INFORMATION >

## SERVICE INFORMATION

### PRECAUTIONS

#### Precaution for Supplemental Restraint System (SRS) "AIR BAG" and "SEAT BELT PRE-TENSIONER"

INFOID:000000004857507

The Supplemental Restraint System such as "AIR BAG" and "SEAT BELT PRE-TENSIONER", used along with a front seat belt, helps to reduce the risk or severity of injury to the driver and front passenger for certain types of collision. This system includes seat belt switch inputs and dual stage front air bag modules. The SRS system uses the seat belt switches to determine the front air bag deployment, and may only deploy one front air bag, depending on the severity of a collision and whether the front occupants are belted or unbelted. Information necessary to service the system safely is included in the SRS and SB section of this Service Manual.

#### **WARNING:**

- To avoid rendering the SRS inoperative, which could increase the risk of personal injury or death in the event of a collision which would result in air bag inflation, all maintenance must be performed by an authorized NISSAN/INFINITI dealer.
- Improper maintenance, including incorrect removal and installation of the SRS can lead to personal injury caused by unintentional activation of the system. For removal of Spiral Cable and Air Bag Module, see the SRS section.
- Do not use electrical test equipment on any circuit related to the SRS unless instructed to in this Service Manual. SRS wiring harnesses can be identified by yellow and/or orange harnesses or harness connectors.

#### PRECAUTIONS WHEN USING POWER TOOLS (AIR OR ELECTRIC) AND HAMMERS

#### **WARNING:**

- When working near the Airbag Diagnosis Sensor Unit or other Airbag System sensors with the Ignition ON or engine running, DO NOT use air or electric power tools or strike near the sensor(s) with a hammer. Heavy vibration could activate the sensor(s) and deploy the air bag(s), possibly causing serious injury.
- When using air or electric power tools or hammers, always switch the Ignition OFF, disconnect the battery, and wait at least 3 minutes before performing any service.

# POWER SUPPLY ROUTING CIRCUIT

< SERVICE INFORMATION >

## POWER SUPPLY ROUTING CIRCUIT

### Schematic

INFOID:000000004306649

For detailed ground distribution, refer to [PG-29. "Ground Distribution"](#).

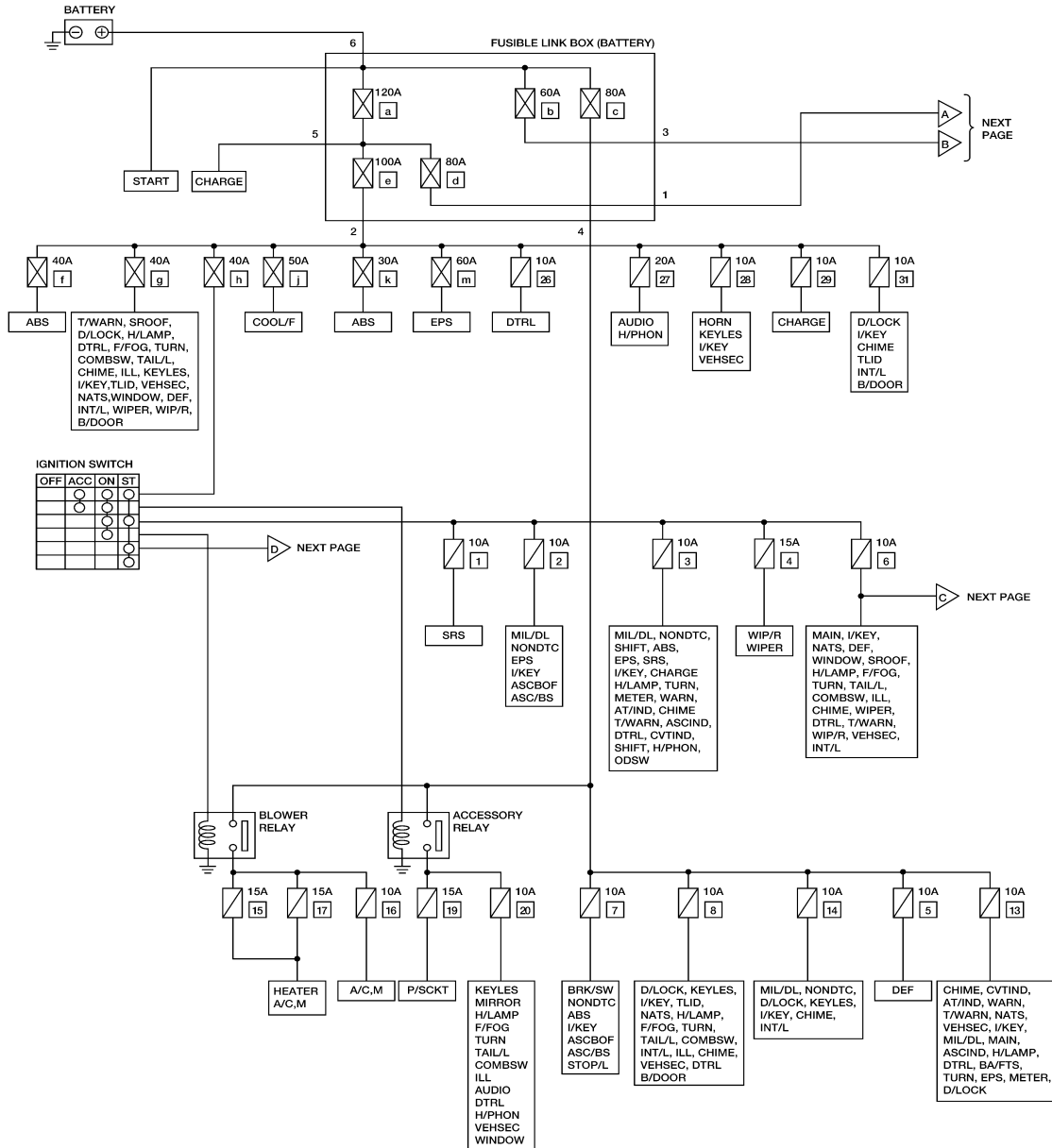

A  
B  
C  
D  
E  
F  
G  
H  
I  
J  
L  
M  
N  
O  
P

PG

WKWA5820E

# POWER SUPPLY ROUTING CIRCUIT

< SERVICE INFORMATION >

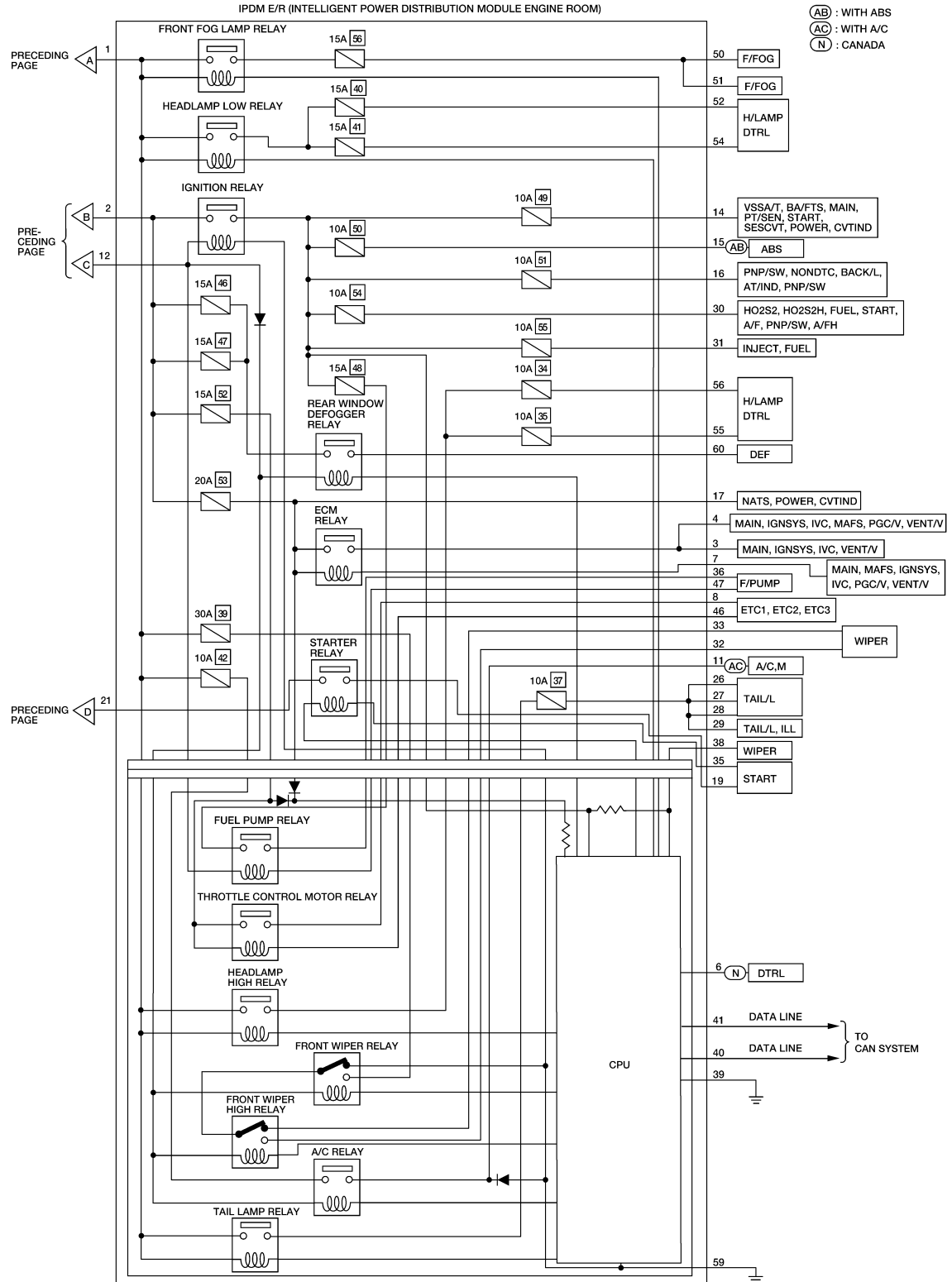

AAMWA0094GI

# POWER SUPPLY ROUTING CIRCUIT

< SERVICE INFORMATION >

## Wiring Diagram - POWER -

INFOID:00000004306650

### BATTERY POWER SUPPLY — IGNITION SWITCH IN ANY POSITION

PG-POWER-01

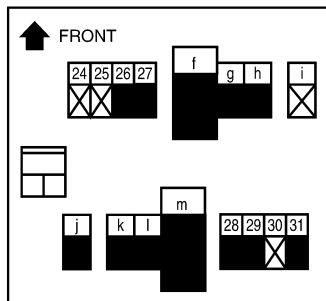
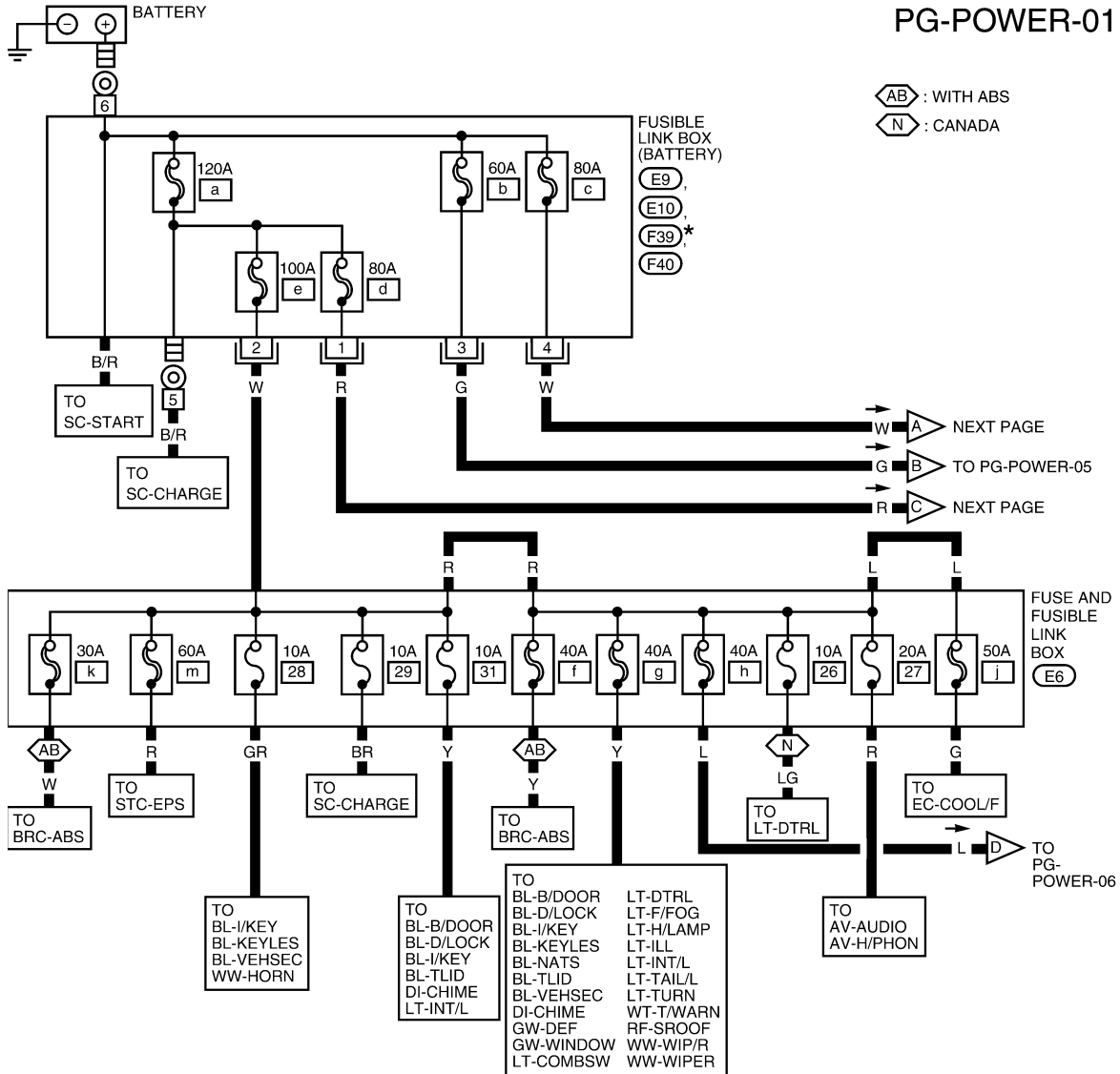

(E6)

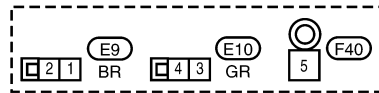

\* : (F39) IS AN INTEGRAL PART OF FUSIBLE LINK BOX (BATTERY) ASSEMBLY.

AWMWA0065G

# POWER SUPPLY ROUTING CIRCUIT

< SERVICE INFORMATION >

PG-POWER-02

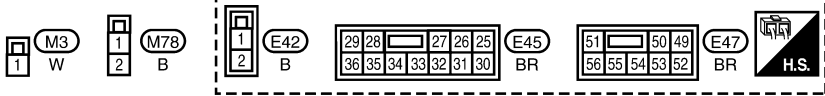
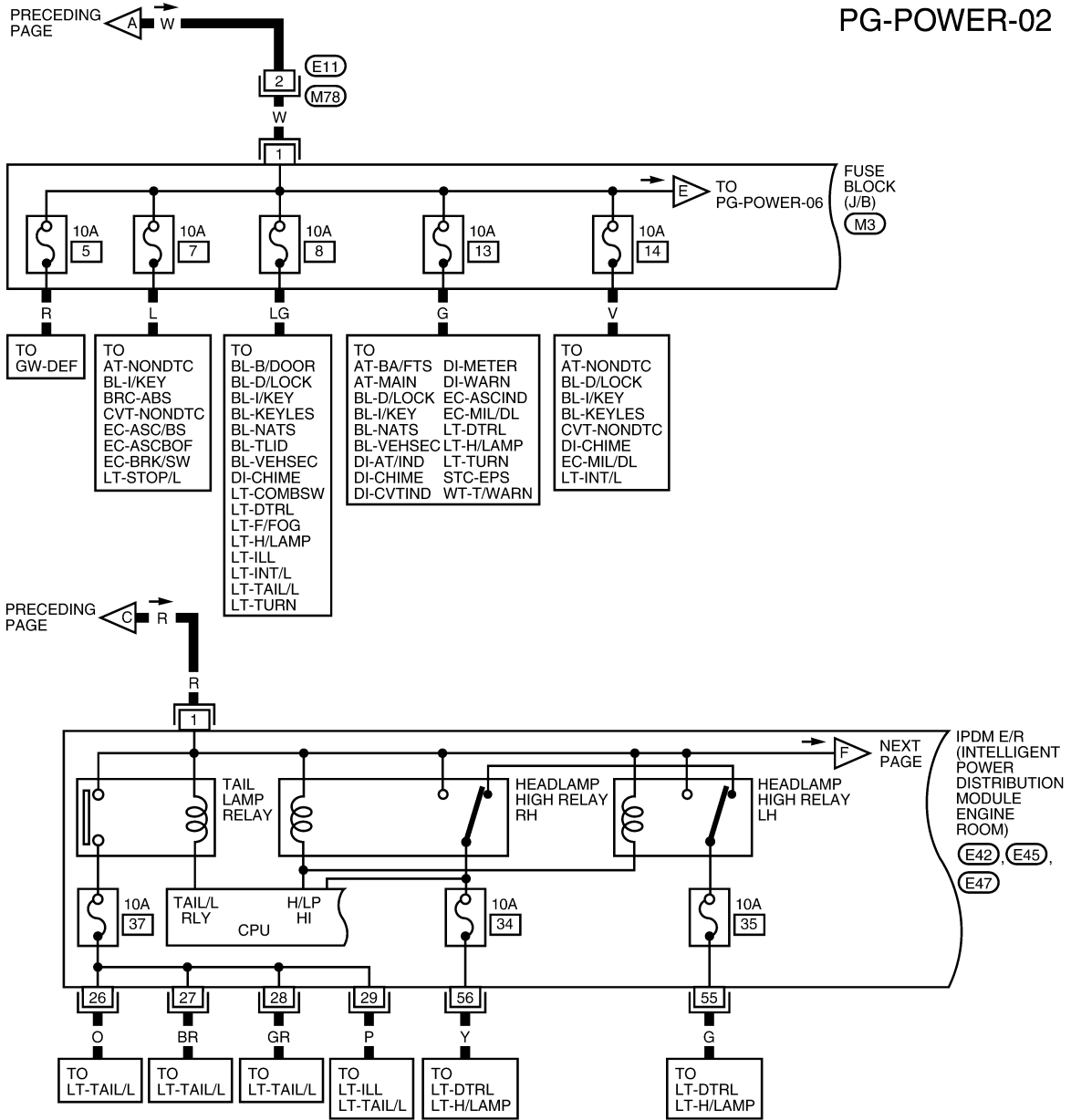

REFER TO THE FOLLOWING.

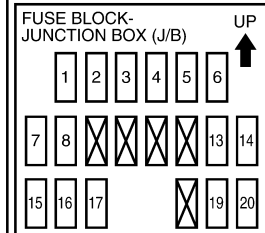

WKWA5822E

# POWER SUPPLY ROUTING CIRCUIT

< SERVICE INFORMATION >

PG-POWER-03

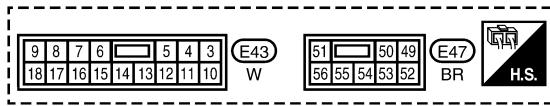
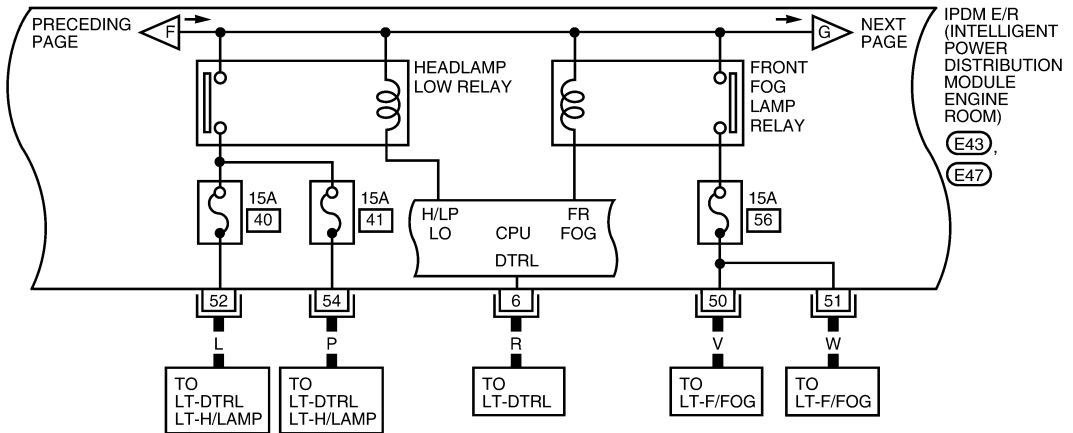

LKWA0374E

A  
B  
C  
D  
E  
F  
G  
H  
I  
J  
PG  
L  
M  
N  
O  
P

# POWER SUPPLY ROUTING CIRCUIT

< SERVICE INFORMATION >

PG-POWER-04

AC : WITH A/C

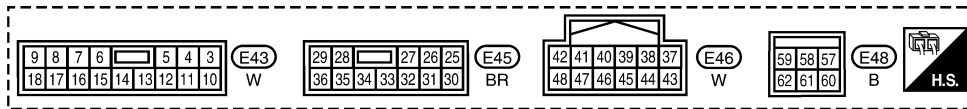
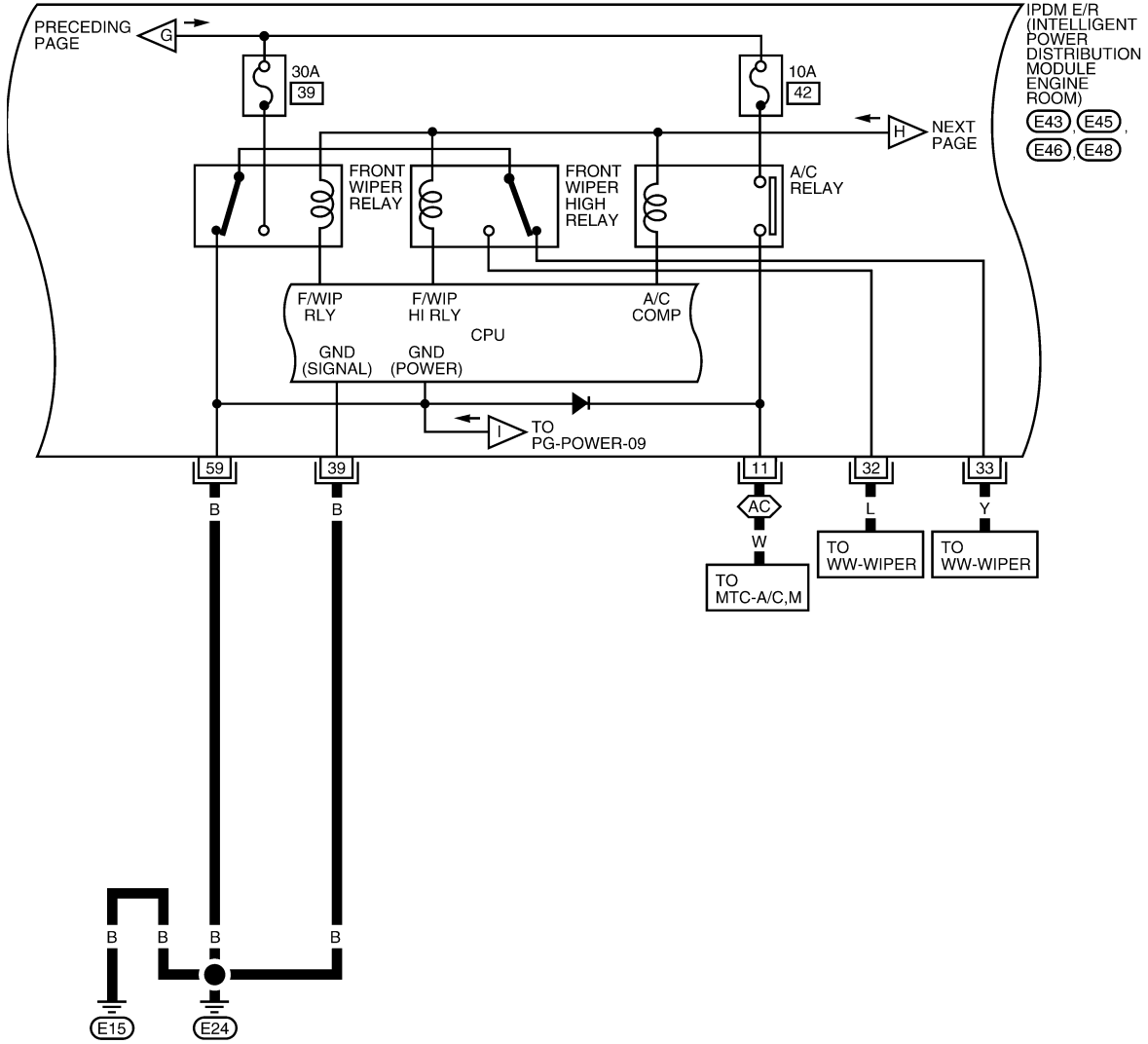

AWMWA0066G



# POWER SUPPLY ROUTING CIRCUIT

< SERVICE INFORMATION >

PG-POWER-05

— : DATA LINE

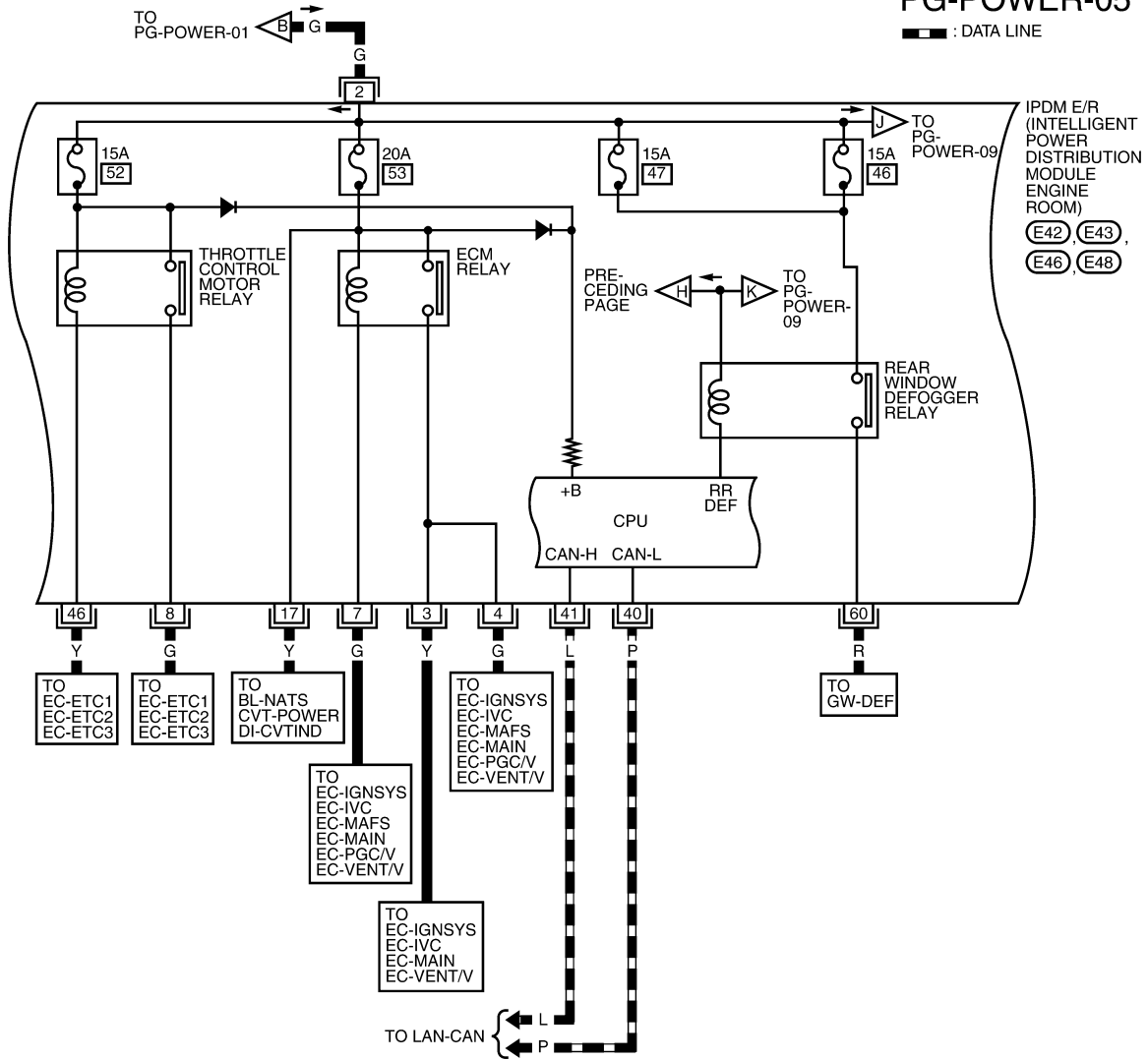

IPDM E/R  
(INTELLIGENT  
POWER  
DISTRIBUTION  
MODULE  
ENGINE  
ROOM)  
E42 E43  
E46 E48

A  
B  
C  
D  
E  
F  
G  
H  
I  
J  
L  
M  
N  
O  
P

PG

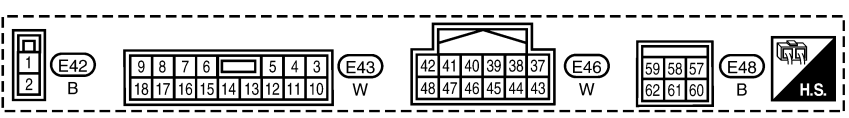

LKWA0376E

# POWER SUPPLY ROUTING CIRCUIT

< SERVICE INFORMATION >

## ACCESSORY POWER SUPPLY — IGNITION SWITCH IN ACC AND/OR ON

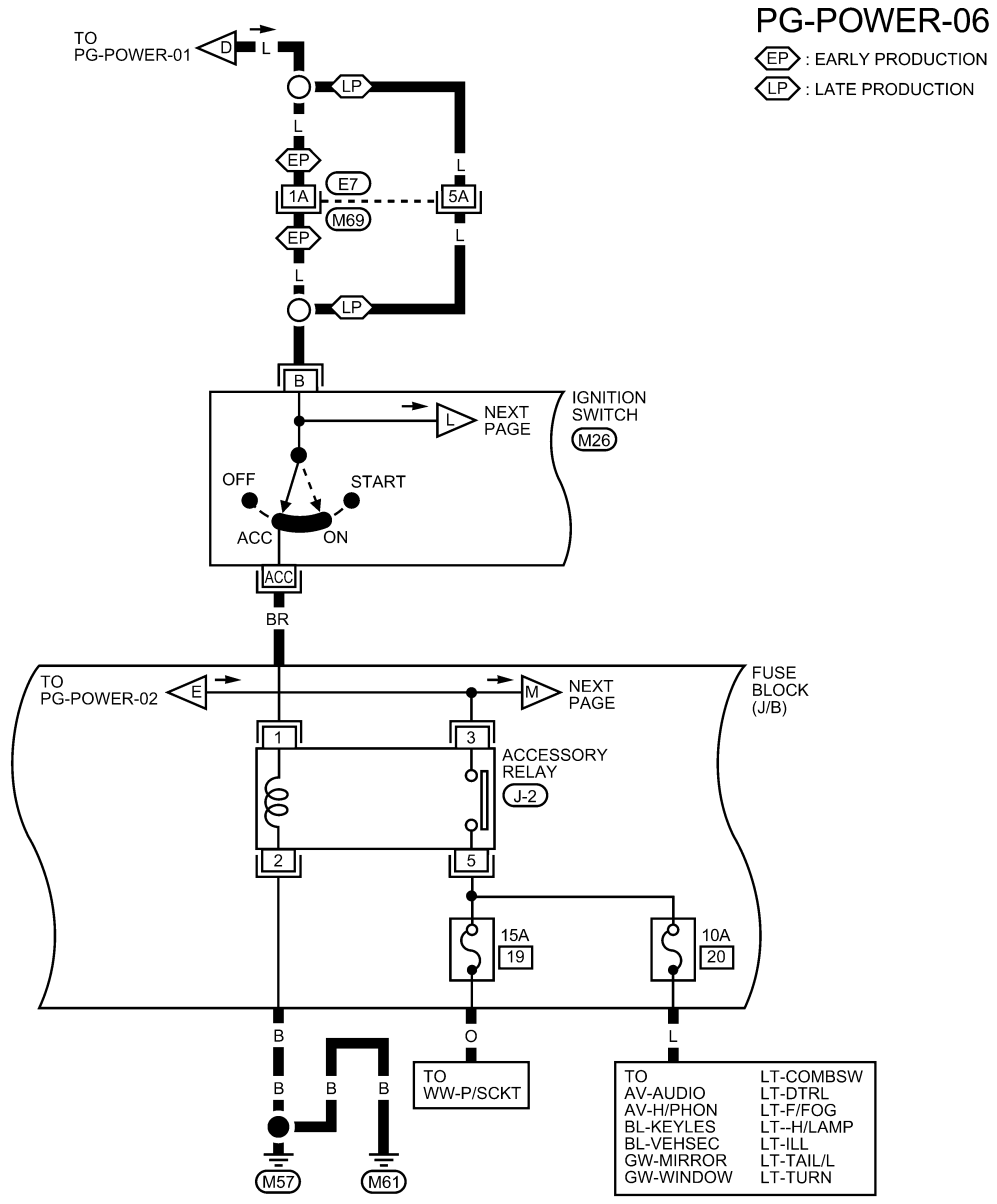

PG-POWER-06

EP : EARLY PRODUCTION

LP : LATE PRODUCTION

IG1	ST	B	(M26) W
IG2	ACC	R	

REFER TO THE FOLLOWING.

(M69) - SUPER MULTIPLE JUNCTION (SMJ)

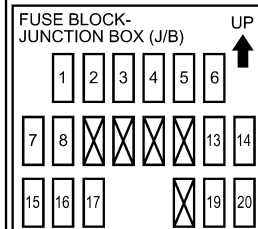

AAMWA0066GI

# POWER SUPPLY ROUTING CIRCUIT

< SERVICE INFORMATION >

IGNITION POWER SUPPLY — IGNITION SWITCH IN ON

PG-POWER-07

 : WITH A/C

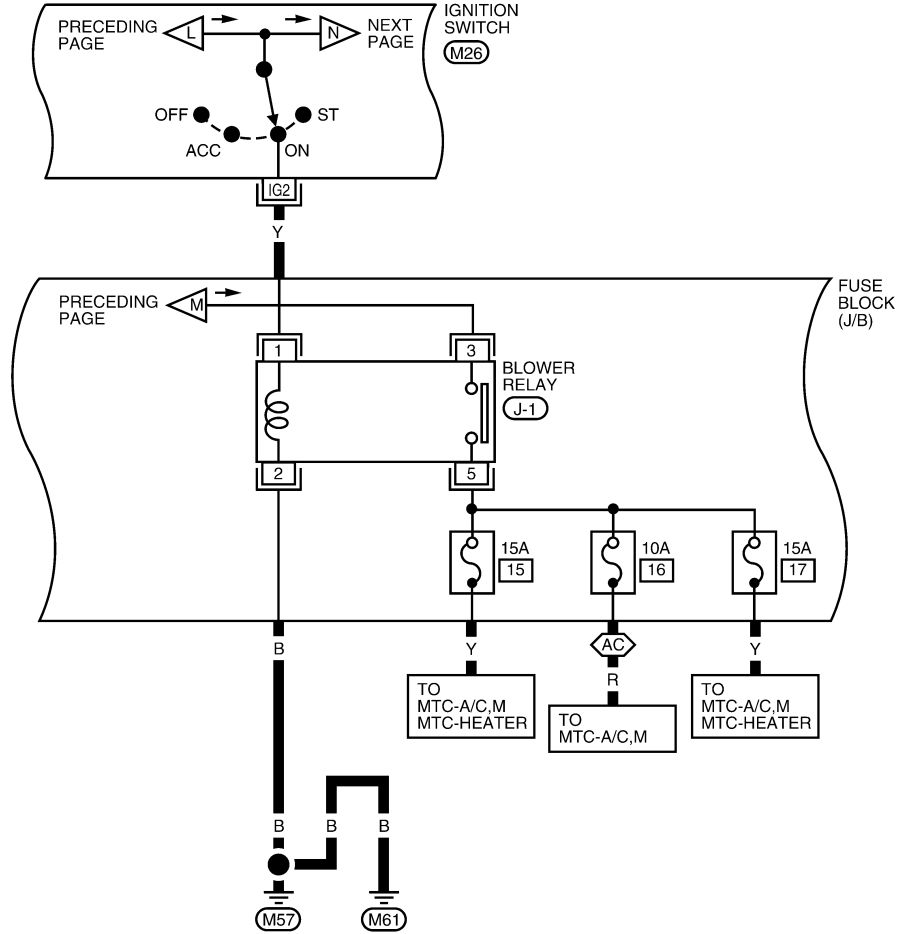

IG1	ST	B	(M26)
IG2	ACC	R	

W

REFER TO THE FOLLOWING.

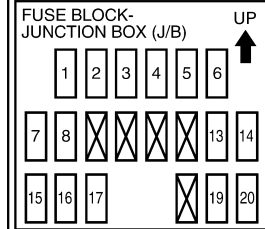

AWMWA0067G

A  
B  
C  
D  
E  
F  
G  
H  
I  
J  
L  
M  
N  
O  
P

PG

# POWER SUPPLY ROUTING CIRCUIT

< SERVICE INFORMATION >

IGNITION POWER SUPPLY — IGNITION SWITCH IN ON AND/OR START.

PG-POWER-08

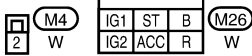
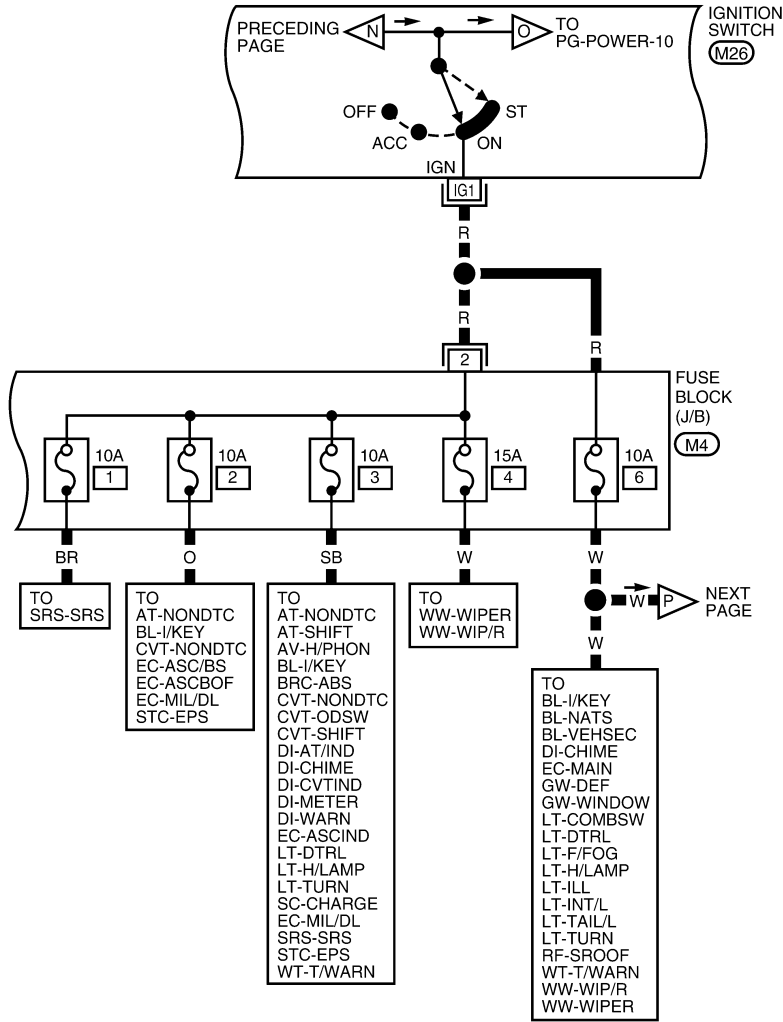

REFER TO THE FOLLOWING.

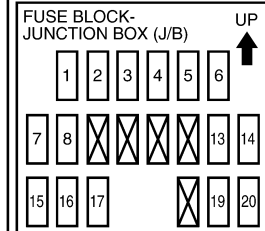

LKWA0379E

# POWER SUPPLY ROUTING CIRCUIT

< SERVICE INFORMATION >

## PG-POWER-09

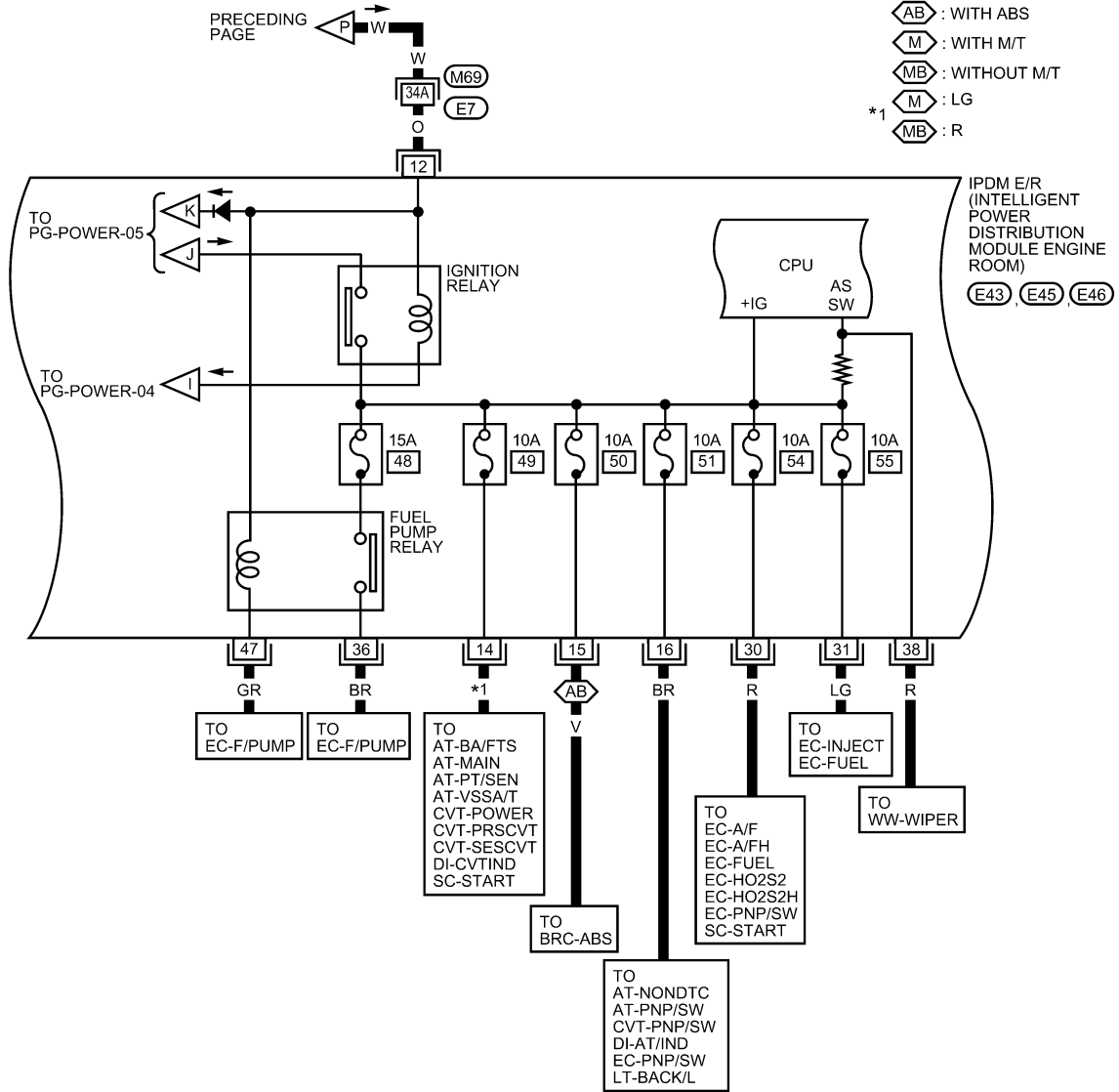

- ⬡ AB : WITH ABS
- ⬡ M : WITH M/T
- ⬡ MB : WITHOUT M/T
- \*1 ⬡ M : LG
- ⬡ MB : R

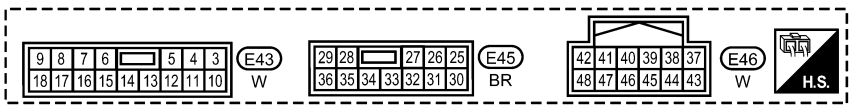

REFER TO THE FOLLOWING.  
 (M69) - SUPER MULTIPLE JUNCTION (SMJ)

AAMWA0068GI

# POWER SUPPLY ROUTING CIRCUIT

< SERVICE INFORMATION >

IGNITION POWER SUPPLY — IGNITION SWITCH IN START

## PG-POWER-10

⬠EP⬠ : EARLY PRODUCTION  
 ⬠LP⬠ : LATE PRODUCTION

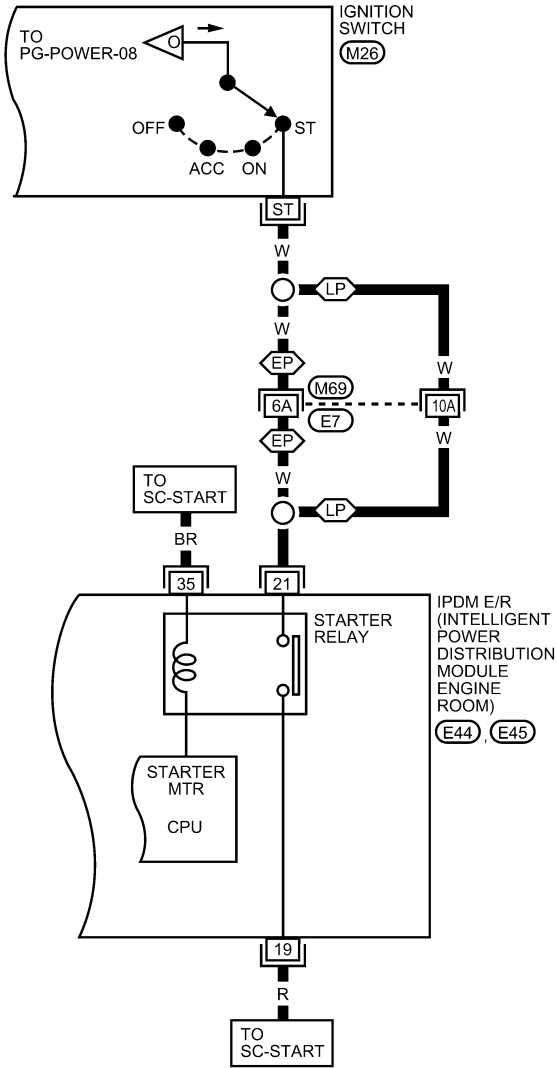

IG1	ST	B	(M26)
IG2	ACC	R	W

21	20	19	(E44)
24	23	22	W

29	28	27	26	25	(E45)		
36	35	34	33	32	31	30	BR



REFER TO THE FOLLOWING.  
 ⬠M69⬠ - SUPER MULTIPLE JUNCTION (SMJ)

AAMWA0067GI

# POWER SUPPLY ROUTING CIRCUIT

< SERVICE INFORMATION >

## Fuse

INFOID:000000004306651

- If fuse is blown, be sure to eliminate cause of malfunction before installing new fuse.
- Use fuse of specified rating. Never use fuse of more than specified rating.
- Do not partially install fuse; always insert it into fuse holder properly.
- Remove fuse for "ELECTRICAL PARTS (BAT)" if vehicle is not used for a long period of time.

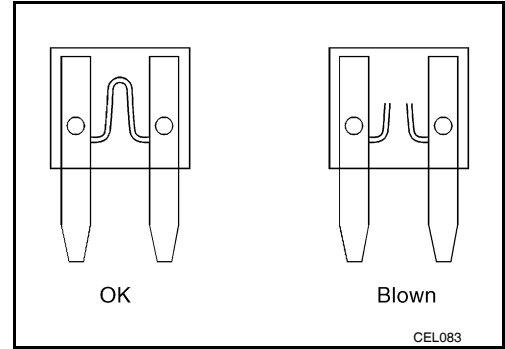

## Fusible Link

INFOID:000000004306652

A melted fusible link can be detected either by visual inspection or by feeling with finger tip. If its condition is questionable, use circuit tester or test lamp.

**CAUTION:**

- If fusible link should melt, it is possible that critical circuit (power supply or large current carrying circuit) is shorted. In such a case, carefully check and eliminate cause of malfunction.
- Never wrap outside of fusible link with vinyl tape. Important: Never let fusible link touch any other wiring harness, vinyl or rubber parts.

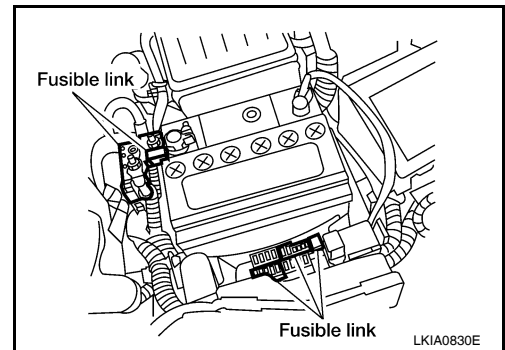

## Circuit Breaker (Built Into BCM)

INFOID:000000004306653

For example, when current is 30A, the circuit is broken within 8 to 20 seconds.

A circuit breaker is used for the following systems:

- Power windows
- Power sunroof

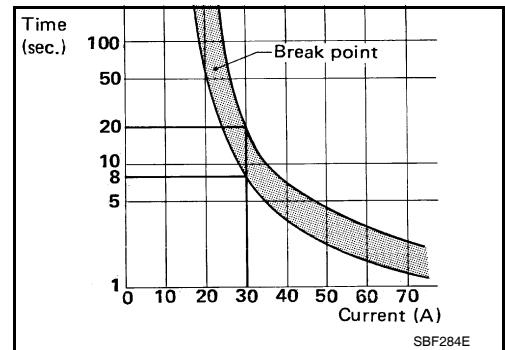

## Circuit Breaker

INFOID:000000004306654

The PTC thermistor generates heat in response to current flow. The temperature (and resistance) of the thermistor element varies with current flow. Excessive current flow will cause the element's temperature to rise. When the temperature reaches a specified level, the electrical resistance will rise sharply to control the circuit current. Reduced current flow will cause the element to cool. Resistance falls accordingly and normal circuit current flow is allowed to resume.

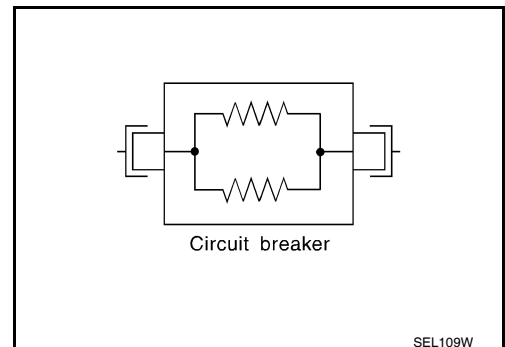

# IPDM E/R (INTELLIGENT POWER DISTRIBUTION MODULE ENGINE ROOM)

< SERVICE INFORMATION >

## IPDM E/R (INTELLIGENT POWER DISTRIBUTION MODULE ENGINE ROOM)

### System Description

INFOID:000000004306655

- IPDM E/R (Intelligent Power Distribution Module Engine Room) integrates the relay box and fuse block which were originally placed in engine compartment. It controls integrated relays via IPDM E/R control circuits.
- IPDM E/R-integrated control circuits perform ON-OFF operation of relays, CAN communication control, oil pressure switch signal reception, etc.
- It controls operation of each electrical component via ECM, BCM and CAN communication lines.

#### **CAUTION:**

**None of the IPDM E/R integrated relays can be removed.**

### SYSTEMS CONTROLLED BY IPDM E/R

1. Lamp control  
Using CAN communication lines, it receives signals from the BCM and controls the following lamps:
  - Headlamps (High, Low)
  - Parking lamps
  - Tail and license plate lamps
  - Front fog lamps
2. Wiper control  
Using CAN communication lines, it receives signals from the BCM and controls the front wipers.
3. Rear window defogger relay control  
Using CAN communication lines, it receives signals from the BCM and controls the rear window defogger relay.
4. A/C compressor control  
Using CAN communication lines, it receives signals from the ECM and controls the A/C compressor (magnet clutch).
5. Starter control  
Using CAN communication lines, it receives signals from the BCM and controls the starter relay.
6. Cooling fan control  
Using CAN communication lines, it receives signals from the ECM and controls the cooling fan relays.
7. Horn control  
Using CAN communication lines, it receives signals from the BCM and controls the horn relay.
8. Daytime light system control (Canada only)  
Using CAN communication lines, it receives signals from the BCM and controls the daytime light relay.

### CAN COMMUNICATION LINE CONTROL

With CAN communication, by connecting each control unit using two communication lines (CAN L-line, CAN H-line), it is possible to transmit a maximum amount of information with minimum wiring. Each control unit can transmit and receive data, and reads necessary information only.

1. Fail-safe control
  - When CAN communication with other control units is impossible, IPDM E/R performs fail-safe control. After CAN communication returns to normal operation, it also returns to normal control.
  - Operation of control parts by IPDM E/R during fail-safe mode is as follows:

Controlled system	Fail-safe mode
Headlamp	<ul style="list-style-type: none"><li>• With the ignition switch ON, headlamp low relay is ON, headlamp high relays are OFF, and daytime light system (Canada only) is OFF.</li><li>• With the ignition switch OFF, the headlamp relays are OFF.</li></ul>
Tail, license plate and parking lamps	<ul style="list-style-type: none"><li>• With the ignition switch ON, the tail lamp relay is ON.</li><li>• With the ignition switch OFF, the tail lamp relay is OFF.</li></ul>
Cooling fan	<ul style="list-style-type: none"><li>• With the ignition switch ON, cooling fan relay-1, relay-2, and relay-3 are ON.</li><li>• With the ignition switch OFF, all cooling fan relays are OFF.</li></ul>
Front wiper	Until the ignition switch is turned off, the front wiper relays remain in the same status they were in just before fail-safe control was initiated.



# IPDM E/R (INTELLIGENT POWER DISTRIBUTION MODULE ENGINE ROOM)

## < SERVICE INFORMATION >

Controlled system	Fail-safe mode
Rear window defogger	Rear window defogger relay OFF
A/C compressor	A/C relay is OFF
Front fog lamps	Front fog lamp relay OFF

### IPDM E/R STATUS CONTROL

In order to save power, IPDM E/R switches status by itself based on each operating condition.

- CAN communication status
  - CAN communication is normally performed with other control units.
  - Individual unit control by IPDM E/R is normally performed.
  - When sleep request signal is received from BCM, mode is switched to sleep waiting status.
- Sleep waiting status
  - Process to stop CAN communication is activated.
  - All systems controlled by IPDM E/R are stopped. When 1 second has elapsed after CAN communication with other control units is stopped, mode switches to sleep status.
- Sleep status
  - IPDM E/R operates in low current-consumption mode.
  - CAN communication is stopped.
  - When a change in CAN communication signal is detected, mode switches to CAN communication status.
  - When a change in ignition switch signal is detected, mode switches to CAN communication status.

### CAN Communication System Description

INFOID:000000004306656

Refer to [LAN-8, "System Diagram"](#).

### Function of Detecting Ignition Relay Malfunction

INFOID:000000004306657

- When the integrated ignition relay is stuck in a "closed contact" position and cannot be turned OFF, IPDM E/R turns ON tail and parking lamps for 10 minutes to indicate IPDM E/R malfunction.
- When the state of the integrated ignition relay does not agree with the state of the ignition switch signal received via CAN communication, the IPDM E/R activates the tail lamp relay.

Ignition switch signal	Ignition relay status	Tail lamp relay
ON	ON	—
OFF	OFF	—
ON	OFF	—
OFF	ON	ON (10 minutes)

#### NOTE:

When the ignition switch is turned ON, the tail lamps are OFF.

### CONSULT-III Function (IPDM E/R)

INFOID:000000004306658

CONSULT-III can display each diagnostic item using the diagnostic test modes shown following.

IPDM E/R diagnostic Mode	Description
SELF-DIAG RESULTS	Displays IPDM E/R self-diagnosis results.
DATA MONITOR	Displays IPDM E/R input/output data in real time.
CAN DIAG SUPPORT MNTR	The result of transmit/receive diagnosis of CAN communication can be read.
ACTIVE TEST	Operation of electrical loads can be checked by sending drive signal to them.

### SELF-DIAGNOSTIC RESULTS

Display Item List

# IPDM E/R (INTELLIGENT POWER DISTRIBUTION MODULE ENGINE ROOM)

## < SERVICE INFORMATION >

Display items	CONSULT-III display code	Malfunction detection	TIME		Possible causes
			CRNT	PAST	
NODTC IS DETECTED. FURTHER TESTING MAY BE REQUIRED.	—	—	—	—	—
CAN COMM CIRC	U1000	<ul style="list-style-type: none"> <li>If CAN communication reception/transmission data has a malfunction, or if any of the control units fail, data reception/transmission cannot be confirmed.</li> <li>When the data in CAN communication is not received before the specified time.</li> </ul>	X	X	Any of items listed below have errors: <ul style="list-style-type: none"> <li>TRANSMIT DIAG</li> <li>ECM</li> <li>BCM/SEC</li> </ul>
IGN RELAY ON	—	When the ignition switch is not in the ON position, the ignition relay in the IPDM E/R is ON.	X	X	Ignition relay (integrated in IPDM E/R)
IGN RELAY OFF	—	When the ignition switch is not in the ON position, the ignition relay in the IPDM E/R is OFF.	X	X	Ignition relay (integrated in IPDM E/R)
EEPROM	—	Malfunction is detected with the integrated EEPROM memory diagnosis.	X	X	IPDM E/R

x: Applicable

### NOTE:

The details for display of the period are as follows:

- CRNT: Error currently detected with IPDM E/R.
- PAST: Error detected in the past and placed in IPDM E/R memory.

### DATA MONITOR

All Signals, Main Signals, Selection From Menu

Item name	CONSULT-III screen display	Display or unit	Monitor item selection			Description
			ALL SIGNALS	MAIN SIGNALS	SELECTION FROM MENU	
Motor fan request	MOTOR FAN REQ	1/2/3/4	X	X	X	Signal status input from ECM
Compressor request	AC COMP REQ	ON/OFF	X	X	X	Signal status input from ECM
Parking, license, and tail lamp request	TAIL & CLR REQ	ON/OFF	X	X	X	Signal status input from BCM
Headlamp low beam request	HL LO REQ	ON/OFF	X	X	X	Signal status input from BCM
Headlamp high beam request	HL HI REQ	ON/OFF	X	X	X	Signal status input from BCM
Front fog request	FR FOG REQ	ON/OFF	X	X	X	Signal status input from BCM
FR wiper request	FR WIP REQ	STOP/1LO/LO/HI	X	X	X	Signal status input from BCM
Wiper auto stop	WIP AUTO STOP	ACT P/STOP P	X	X	X	Output status of IPDM E/R
Wiper protection	WIP PROT	OFF/LS/HS/Block	X	X	X	Control status of IPDM E/R
Starter request	ST RLY REQ	ON/OFF	X		X	Status of input signal (*1)
Ignition relay status	IGN RLY	ON/OFF	X	X	X	Ignition relay status monitored with IPDM E/R
Rear defogger request	RR DEF REQ	ON/OFF	X	X	X	Signal status input from BCM
Oil pressure switch	OIL P SW	OPEN/CLOSE	X		X	Signal status input from IPDM E/R
Hood switch	HOOD SW (*2)	OFF	X		X	Signal status input from IPDM E/R

# IPDM E/R (INTELLIGENT POWER DISTRIBUTION MODULE ENGINE ROOM)

## < SERVICE INFORMATION >

Item name	CONSULT-III screen display	Display or unit	Monitor item selection			Description
			ALL SIGNALS	MAIN SIGNALS	SELECTION FROM MENU	
Theft warning horn request	THFT HRN REQ	ON/OFF	X		X	Signal status input from BCM
Horn chirp	HORN CHIRP	ON/OFF	X		X	Output status of IPDM E/R
Daytime light request	DTRL REQ	ON/OFF	X		X	Signal status input from BCM

\*1 Perform monitoring of IPDM E/R data with the ignition switch ON. When the ignition switch is in ACC position, display may not be correct.

\*2 This item is displayed, but does not function.

### CAN DIAG SUPPORT MNTR

Refer to [LAN-10. "Description"](#).

### ACTIVE TEST

#### Display Item List

Test name	CONSULT-III screen display	Description
Head, tail, fog lamp output	EXTERNAL LAMPS	With a certain ON-OFF operation (OFF, TAIL, LO, HI, FOG), the front fog lamp, headlamp low, headlamp high RH, headlamp high LH, and tail lamp relays can be operated.
Rear defogger output	REAR DEFOGGER	With a certain ON-OFF operation, the rear defogger relay can be operated.
Front wiper (HI, LO) output	FRONT WIPER	With a certain operation (OFF, HI ON, LO ON), the front wiper relays (Lo, Hi) can be operated.
Cooling fan output	MOTOR FAN	With a certain operation (1, 2, 3, 4), the cooling fan relays can be operated.
Horn output	HORN	With a certain ON-OFF operation, the horn relay can be operated.

### Auto Active Test

INFOID:000000004306659

#### DESCRIPTION

- In auto active test mode, operation inspection can be performed when IPDM E/R sends a drive signal to the following systems:
  - Rear window defogger
  - Front wipers
  - Tail, license and parking lamps
  - Daytime lamp system (Canada only)
  - Front fog lamps
  - Headlamps (High, Low)
  - A/C compressor (magnet clutch)
  - Cooling fan

#### OPERATION PROCEDURE

- Close hood and front door RH, and lift wiper arms away from windshield (to prevent glass damage by wiper operation).
 

**NOTE:**  
When auto active test is performed with hood opened, sprinkle water on windshield beforehand.
- Turn ignition switch OFF.
- Turn ignition switch ON and, within 20 seconds, press front door switch LH 20 times. Then turn ignition switch OFF.
- Turn ignition switch ON within 10 seconds after ignition switch OFF.
- When auto active test mode is actuated, horn chirps once.
- After a series of operations is repeated three times, auto active test is completed.

# IPDM E/R (INTELLIGENT POWER DISTRIBUTION MODULE ENGINE ROOM)

## < SERVICE INFORMATION >

**NOTE:**

When auto active test mode has to be cancelled halfway, turn ignition switch OFF.

**CAUTION:**

Be sure to perform [BL-44, "Door Switch Check \(Hatchback\)"](#) when the auto active test cannot be performed.

### INSPECTION IN AUTO ACTIVE TEST MODE

When auto active test mode is actuated, the following six steps are repeated three times.

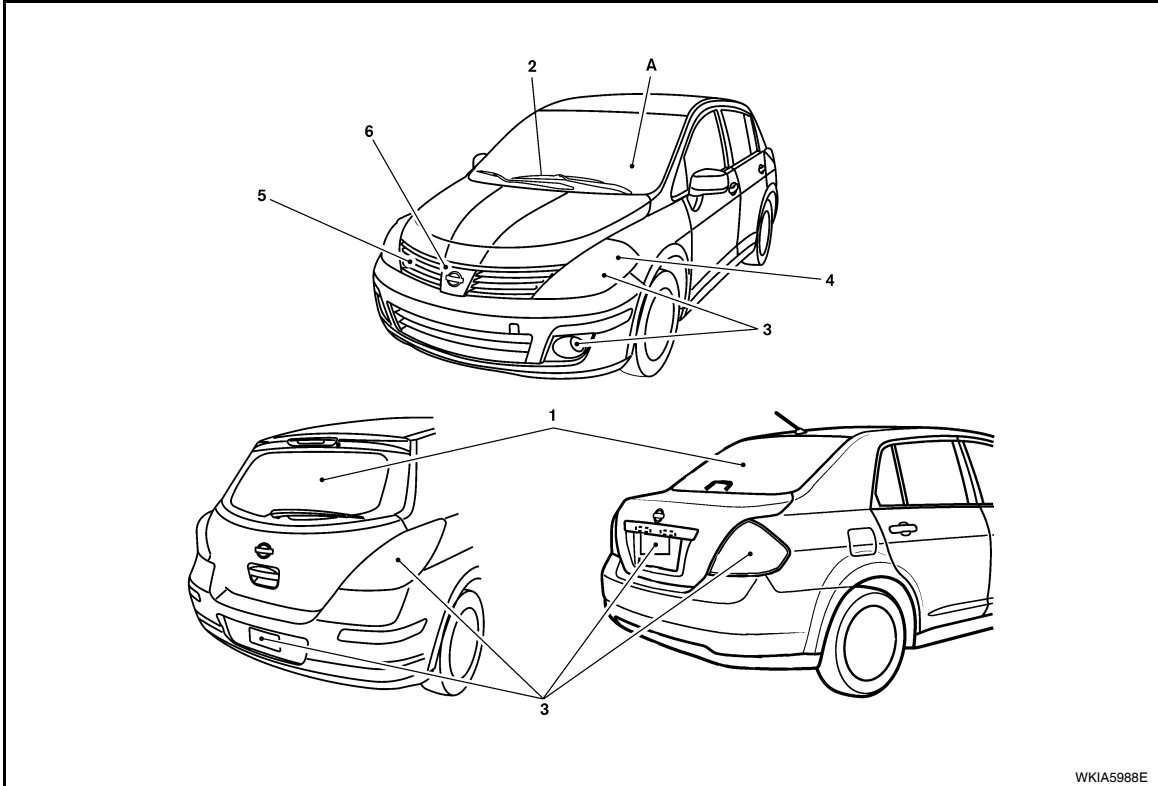

(A): Oil pressure warning lamp is blinking when the auto active test is operating.

Item Number	Test Item	Operation Time/Frequency
1	Rear window defogger	10 seconds
2	Front wipers	LOW 5 seconds then HIGH 5 seconds
3	Daytime light system (Canada only)	10 seconds
3	Tail, license, and parking lamps	10 seconds
3	Front fog lamps	10 seconds
4	Headlamps (low)	20 seconds
4	Headlamps (high)	ON-OFF 5 times
5	A/C compressor (magnet clutch)	ON-OFF 5 times
6	Cooling fan	LOW 5 seconds then HIGH 5 seconds

# IPDM E/R (INTELLIGENT POWER DISTRIBUTION MODULE ENGINE ROOM)

## < SERVICE INFORMATION >

### Concept of Auto Active Test

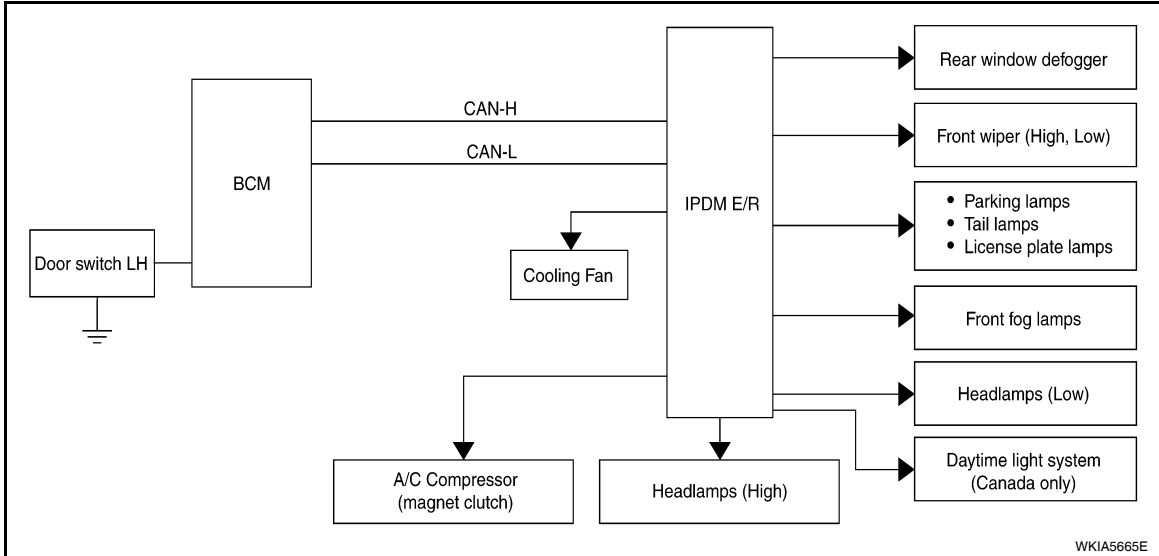

- IPDM E/R actuates auto active test mode when it receives door switch signal from BCM via CAN communication line. Therefore, when auto active test mode is activated successfully, CAN communication between IPDM E/R and BCM is normal.
- If any of the systems controlled by IPDM E/R cannot be operated, possible cause can be easily diagnosed using auto active test.

Diagnosis chart in auto active test mode

Symptom	Inspection contents	Possible cause
Rear window defogger does not operate.	Perform auto active test. Does rear window defogger operate?	YES • BCM signal input circuit
		NO • Rear window defogger relay • Open circuit of rear window defogger • IPDM E/R malfunction • Harness or connector malfunction between IPDM E/R and rear window defogger
Any of front wipers, tail and parking lamps, front fog lamps, daytime light system (Canada only), and headlamps (High, Low) do not operate.	Perform auto active test. Does system in question operate?	YES • BCM signal input system
		NO • Lamp/wiper motor malfunction • Lamp/wiper motor ground circuit malfunction • Harness/connector malfunction between IPDM E/R and system in question • IPDM E/R (integrated relay) malfunction
A/C compressor does not operate.	Perform auto active test. Does magnet clutch operate?	YES • BCM signal input circuit • CAN communication signal between BCM and ECM • CAN communication signal between ECM and IPDM E/R
		NO • Magnet clutch malfunction • Harness/connector malfunction between IPDM E/R and magnet clutch • IPDM E/R (integrated relay) malfunction
Cooling fan does not operate.	Perform auto active test. Does cooling fan operate?	YES • ECM signal input circuit • CAN communication signal between ECM and IPDM E/R
		NO • Cooling fan motor malfunction • Harness/connector malfunction between IPDM E/R and cooling fan motor • IPDM E/R (integrated relay) malfunction
Oil pressure warning lamp does not operate.	Perform auto active test. Does oil pressure warning lamp blink?	YES • Harness/connector malfunction between IPDM E/R and oil pressure switch • Oil pressure switch malfunction • IPDM E/R
		NO • CAN communication signal between BCM and combination meter • Combination meter

# IPDM E/R (INTELLIGENT POWER DISTRIBUTION MODULE ENGINE ROOM)

< SERVICE INFORMATION >

## IPDM E/R Terminal Arrangement - Type A

INFOID:000000004857493

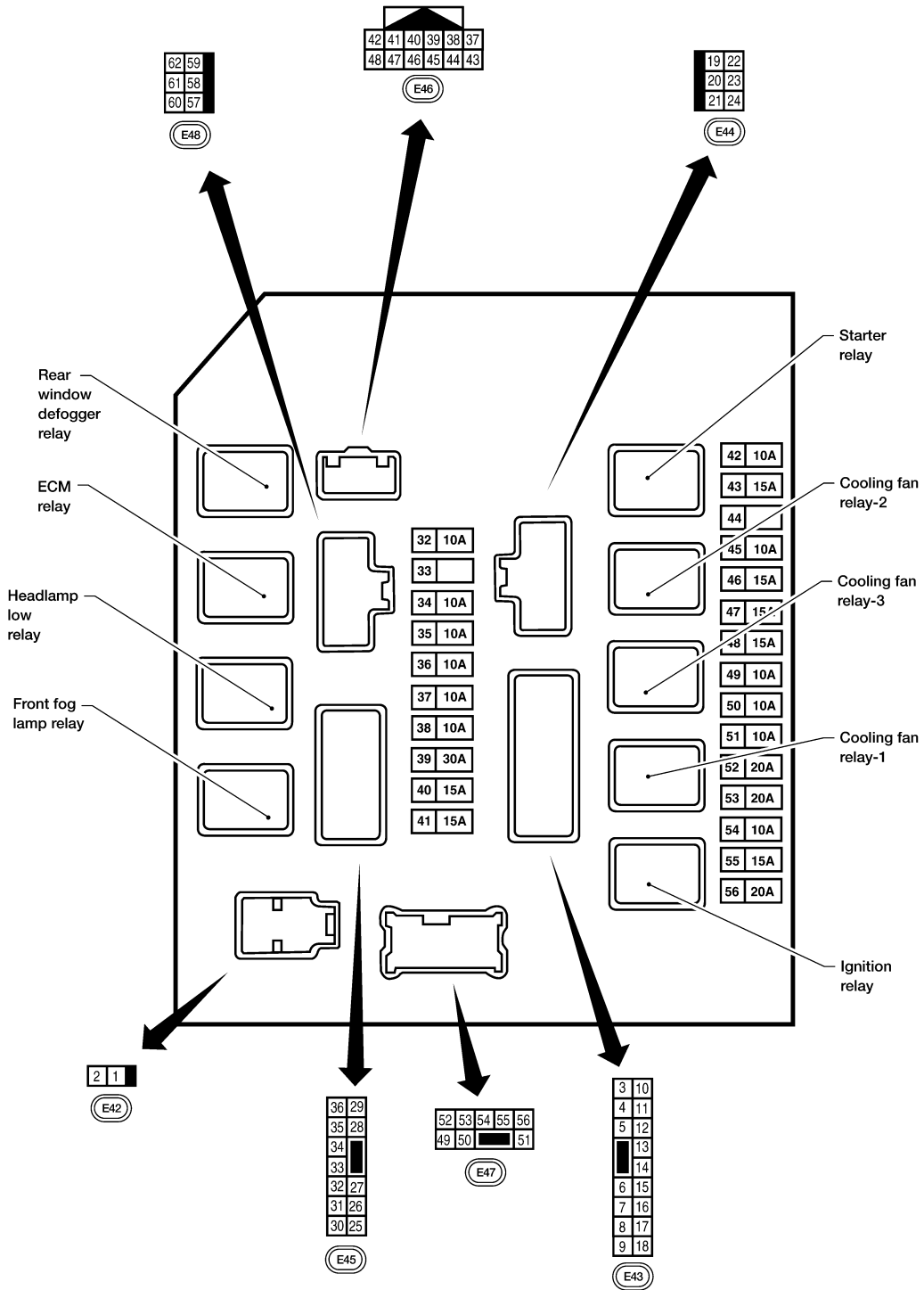

WKIA5666E

# IPDM E/R (INTELLIGENT POWER DISTRIBUTION MODULE ENGINE ROOM)

< SERVICE INFORMATION >

## IPDM E/R Terminal Arrangement - Type B

INFOID:00000004306660

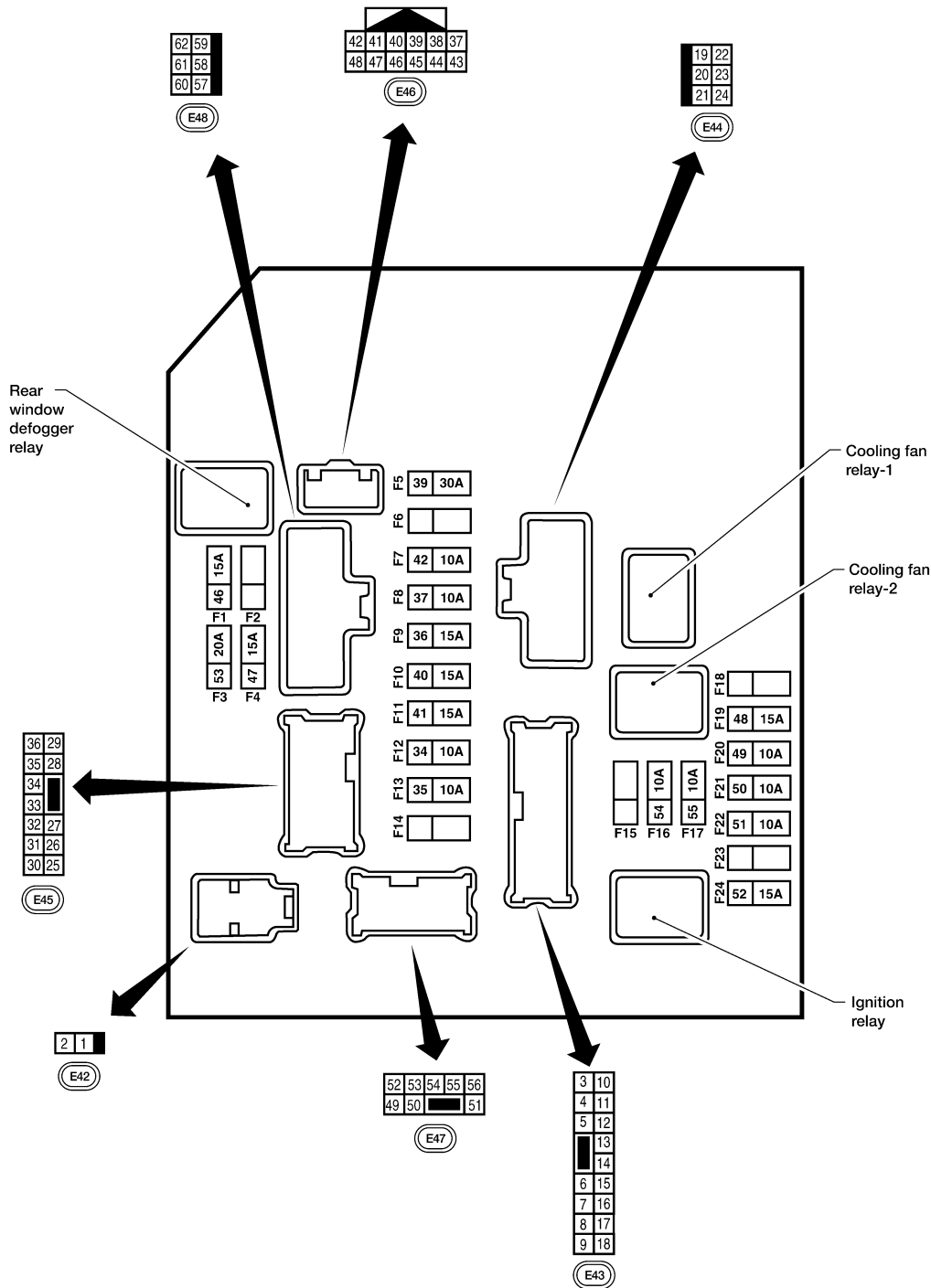

**NOTE:**

Numbers preceded by an "F" represent the fuse numbers imprinted on the IPDM E/R. The other numbers represent the fuse numbers as they appear in the wiring diagrams.

AAMIA0201GB

A  
B  
C  
D  
E  
F  
G  
H  
I  
J  
PG  
L  
M  
N  
O  
P

# IPDM E/R (INTELLIGENT POWER DISTRIBUTION MODULE ENGINE ROOM)

< SERVICE INFORMATION >

## Terminal and Reference Value for IPDM E/R

INFOID:000000004306661

Terminal	Wire color	Signal name	Signal input/output	Measuring condition		Reference value (Approx.)
				Ignition switch	Operation or condition	
1	R	Battery power supply	Input	OFF	—	Battery voltage
2	G	Battery power supply	Input	OFF	—	Battery voltage
3	Y	ECM Relay	Output	—	Ignition switch ON or START	Battery voltage
					Ignition switch OFF or ACC	0V
4	G	ECM relay	Output	—	Ignition switch ON or START	Battery voltage
					Ignition switch OFF or ACC	0V
6	R	Daytime light relay control	Input	ON	Daytime light system active.	Less than battery voltage
					Daytime light system inactive.	Battery voltage
7	G	ECM relay control	Input	—	Ignition switch ON or START	0V
					Ignition switch OFF or ACC	Battery voltage
8	G	Throttle control motor relay	Output	—	Ignition switch ON or START	Battery voltage
					Ignition switch OFF or ACC	0V
11	W	A/C compressor	Output	ON or START	A/C switch ON or defrost A/C switch	Battery voltage
					A/C switch OFF or defrost A/C switch	0V
12	O	Ignition switch supplied power	Input	—	OFF or ACC	0V
					ON or START	Battery voltage
14	LG (M/T) R (A/T or CVT)	Fuse 49	Output	—	Ignition switch ON or START	Battery voltage
					Ignition switch OFF or ACC	0V
15	V	Fuse 50	Output	—	Ignition switch ON or START	Battery voltage
					Ignition switch OFF or ACC	0V
16	BR	Fuse 51	Output	—	Ignition switch ON or START	Battery voltage
					Ignition switch OFF or ACC	0V
17	Y	Battery power supply	Output	—	—	Battery voltage
19	R	Starter motor	Output	START	—	Battery voltage
20	L (with A/C) LG (without A/C)	Cooling fan relay-1	Output	—	Conditions correct for cooling fan low operation.	Battery voltage
					Conditions not correct for cooling fan low operation.	0V
22	G	Battery power supply	Input	—	—	Battery voltage
23	L	Cooling fan relay-2	Input	—	Conditions correct for cooling fan high operation	Battery voltage
					Conditions not correct for cooling fan high operation	0V



# IPDM E/R (INTELLIGENT POWER DISTRIBUTION MODULE ENGINE ROOM)

## < SERVICE INFORMATION >

Terminal	Wire color	Signal name	Signal input/output	Measuring condition		Reference value (Approx.)
				Ignition switch	Operation or condition	
24	Y	Cooling fan relay-3	Output	—	Conditions correct for cooling fan high operation	Battery voltage
					Conditions not correct for cooling fan high operation	0V
26	O	Tail lamp relay (parking lamps)	Output	—	Lighting switch in 2nd position	Battery voltage
27	BR	Tail lamp relay (parking lamps)	Output	—	Lighting switch in 2nd position	Battery voltage
28	GR	Tail lamp relay (parking lamps)	Output	—	Lighting switch in 2nd position	Battery voltage
29	P	Tail lamp relay (parking lamps)	Output	—	Lighting switch in 2nd position	Battery voltage
30 (A/T only)	R	Fuse 54	Output	—	Ignition switch ON or START	Battery voltage
					Ignition switch OFF or ACC	0V
31	O	Fuse 55	Output	—	Ignition switch ON or START	Battery voltage
					Ignition switch OFF or ACC	0V
32	L	Wiper high speed signal	Output	ON or START	Wiper switch OFF, LO, INT	0V
					HI	Battery voltage
33	Y	Wiper low speed signal	Output	ON or START	Wiper switch OFF	0V
					LO or INT	Battery voltage
35	BR	Starter relay (inhibit switch)	Input	ON or START	Selector lever in "P" or "N" (CVT or A/T) or clutch pedal depressed (M/T)	Battery voltage
					Selector lever any other position (CVT or A/T) or clutch pedal released (M/T)	0V
36	BR	Fuel pump relay	Output	—	Ignition switch ON or START	Battery voltage
					Ignition switch OFF or ACC	0V
37	G	Oil pressure switch	Input	ON or START	Engine running and oil pressure within specification	Battery voltage
					Engine not running or oil pressure below specification	0V
38	R	Wiper auto stop signal	Input	ON or START	Wipers not in park position	Battery voltage
					Wipers in park position	0V
39	B	Ground	Input	—	—	0V
40	P	CAN-L	—	ON	—	—
41	L	CAN-H	—	ON	—	—
45	R	Horn relay control	Input	—	Horn switch PUSHED, alarm switch activated or door lock/unlock is confirmed when operating lock system via the keyfob	0V
					Horn switch released, alarm not active, keyfob not active	Battery voltage
46	Y	Throttle control motor relay control	Input	—	Ignition switch ON or START	0V
					Ignition switch OFF or ACC	Battery voltage
47	GR	Fuel pump relay control	Input	—	Ignition switch ON or START	0V
					Ignition switch OFF or ACC	Battery voltage

# IPDM E/R (INTELLIGENT POWER DISTRIBUTION MODULE ENGINE ROOM)

## < SERVICE INFORMATION >

Terminal	Wire color	Signal name	Signal input/output	Measuring condition		Reference value (Approx.)	
				Ignition switch	Operation or condition		
50	V	Front fog lamp (LH)	Output	ON or START	Lighting switch must be in the 2ND position (LOW beam is ON) and the front fog lamp switch	OFF	0V
						ON	Battery voltage
51	W	Front fog lamp (RH)	Output	ON or START	Lighting switch must be in the 2ND position (LOW beam is ON) and the front fog lamp switch	OFF	0V
						ON	Battery voltage
52	L	LH Low beam head-lamp	Output	—	Lighting switch in 2nd position		Battery voltage
54	P	RH Low beam head-lamp	Output	—	Lighting switch in 2nd position		Battery voltage
55	G	LH High beam head-lamp	Output	—	Lighting switch in 2nd position and placed in HIGH or PASS position		Battery voltage
56	Y	RH High beam head-lamp	Output	—	Lighting switch in 2nd position and placed in HIGH or PASS position		Battery voltage
59	B	Ground	Input	—	—		0V
60	R	Rear window defogger relay	Output	ON or START	Rear defogger Switch ON		Battery voltage
					Rear defogger Switch OFF		0V

## IPDM E/R Power/Ground Circuit Inspection

INFOID:000000004306662

### 1. FUSE AND FUSIBLE LINK INSPECTION

Check that the following fusible links or IPDM E/R fuses are not blown.

Terminal No.	Signal name	Fuse, fusible link No.
1, 2	Battery power	a, b, d

#### OK or NG

OK >> GO TO 2.

NG >> Replace fuse or fusible link.

### 2. POWER CIRCUIT INSPECTION

1. Turn ignition switch OFF.
2. Disconnect IPDM E/R harness connector E42.
3. Check voltage between IPDM E/R harness connector E42 terminals 1, 2 and ground.

# IPDM E/R (INTELLIGENT POWER DISTRIBUTION MODULE ENGINE ROOM)

## < SERVICE INFORMATION >

**Battery voltage should exist.**

### OK or NG

- OK >> GO TO 3.
- NG >> Repair or replace IPDM E/R power circuit harness.

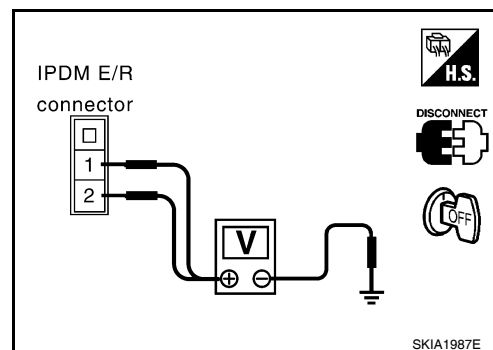

## 3. GROUND CIRCUIT INSPECTION

1. Disconnect IPDM E/R harness connectors E46 and E48.
2. Check continuity between IPDM E/R harness connector E46 (A) terminal 39, E48 (B) terminal 59 and ground.

**Continuity should exist.**

### OK or NG

- OK >> Inspection End.
- NG >> Repair or replace IPDM E/R ground circuit harness.

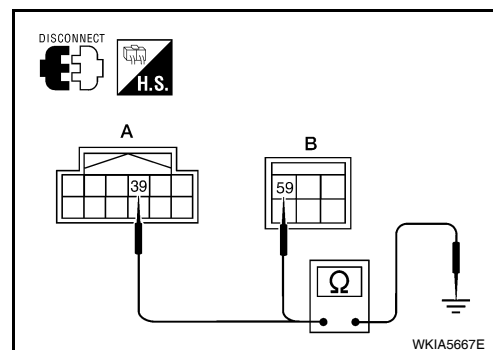

## Inspection with CONSULT-III (Self-Diagnosis)

INFOID:000000004306663

### 1. SELF-DIAGNOSIS RESULT CHECK

1. Connect CONSULT-III and select "IPDM E/R" on the "SELECT SYSTEM" screen.
2. Select "SELF-DIAG RESULTS" on the "SELECT DIAG MODE" screen.
3. Check display content in self-diagnosis results.

CONSULT-III Display	CONSULT-III display code	TIME		Details of diagnosis result
		CRNT	PAST	
NO DTC IS DETECTED. FURTHER TESTING MAY BE REQUIRED.	—	—	—	No malfunction
CAN COMM CIRC	U1000	X	X	Any of items listed below have errors: • TRANSMIT DIAG • ECM • BCM/SEC

### NOTE:

The Details for Display for the Period are as follows:

- CRNT: Error currently detected by IPDM E/R.
- PAST: Error detected in the past and stored in IPDM E/R memory.

### Contents displayed

NO DTC DETECTED. FURTHER TESTING MAY BE REQUIRED.>>Inspection End.

CAN COMM CIRC>>Print out the self-diagnosis result and refer to [LAN-17. "Trouble Diagnosis Flow Chart"](#).

## Removal and Installation of IPDM E/R

INFOID:000000004306664

■: Vehicle front

### REMOVAL

## IPDM E/R (INTELLIGENT POWER DISTRIBUTION MODULE ENGINE ROOM)

### < SERVICE INFORMATION >

1. Lift up the IPDM E/R while pushing and opening pawls (A) or (B), and remove the IPDM E/R while pushing and opening the other side pawls.
2. Disconnect harness connector.

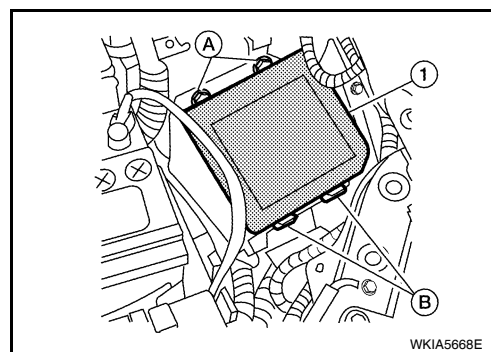

WKIA5668E

### INSTALLATION

Installation is the reverse order of removal.

# GROUND CIRCUIT

< SERVICE INFORMATION >

## GROUND CIRCUIT

### Ground Distribution

INFOID:000000004306665

### MAIN HARNESS

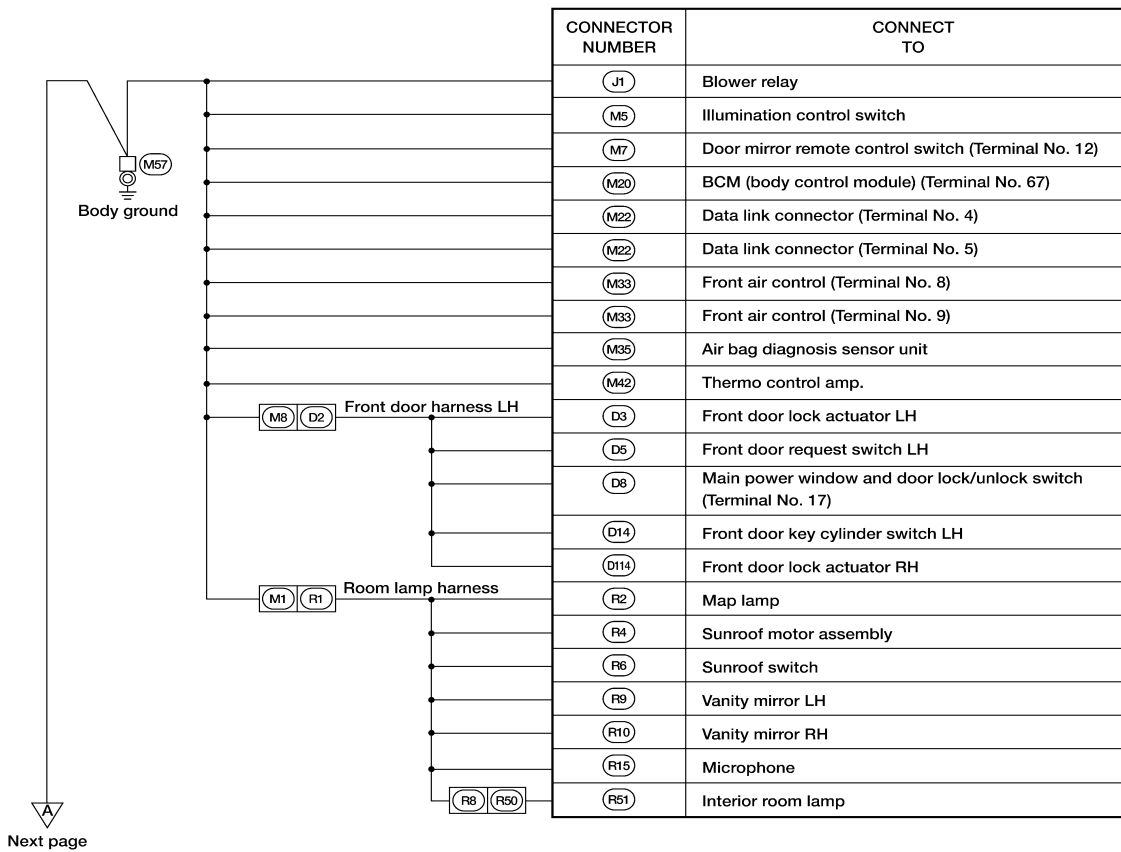
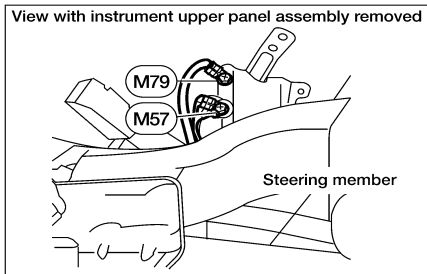

A  
B  
C  
D  
E  
F  
G  
H  
I  
J  
PG  
L  
M  
N  
O  
P

AAMIA0132GB

# GROUND CIRCUIT

< SERVICE INFORMATION >

---

Preceding  
page

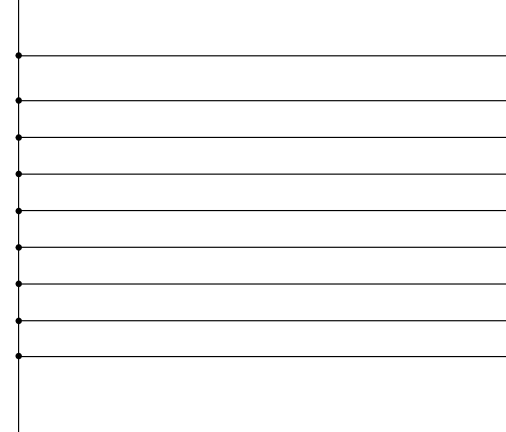

CONNECTOR NUMBER	CONNECT TO
(M10)	Instrument panel antenna (shield) (with hatchback early production)
(M36)	Front passenger airbag OFF indicator
(M38)	A/T device (Terminal No. 2)
(M38)	A/T device (Terminal No. 6)
(M38)	CVT device (Terminal No. 6)
(M38)	CVT device (Terminal No. 2)
(M52)	Intelligent key unit
(M55)	Hazard switch
(M73)	Key switch and ignition knob switch



Next page

AAMIA0133GB

# GROUND CIRCUIT

< SERVICE INFORMATION >

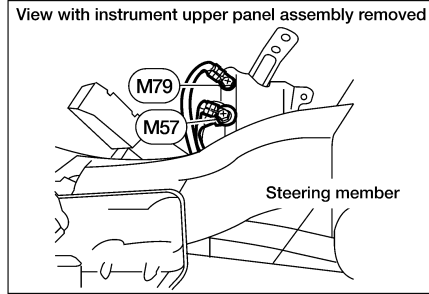
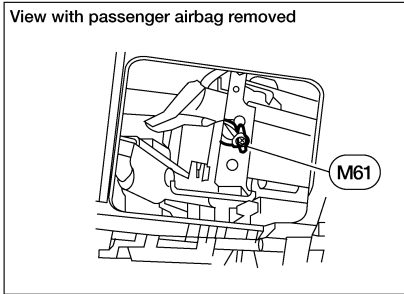

Preceding page

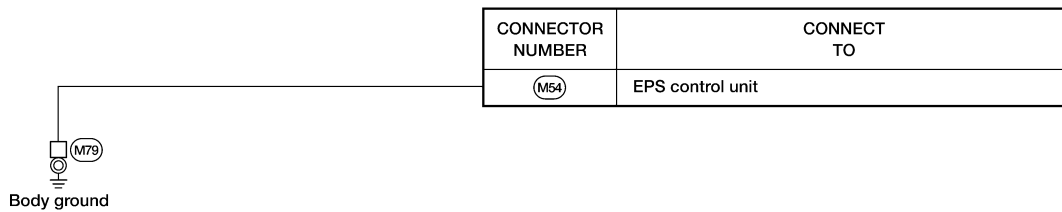
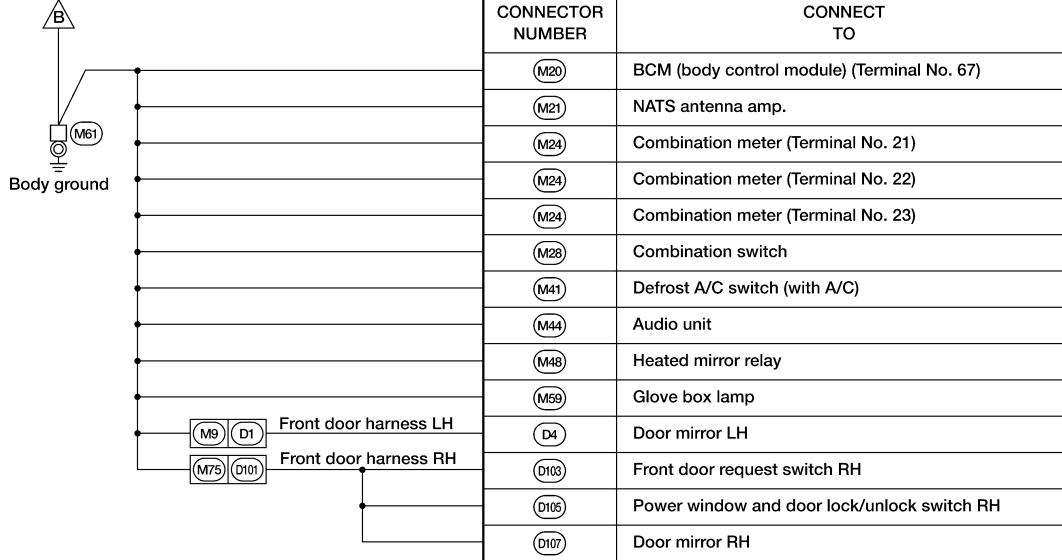

AWMIA0141GB

A  
B  
C  
D  
E  
F  
G  
H  
I  
J  
PG  
L  
M  
N  
O  
P

# GROUND CIRCUIT

< SERVICE INFORMATION >

## ENGINE ROOM HARNESS

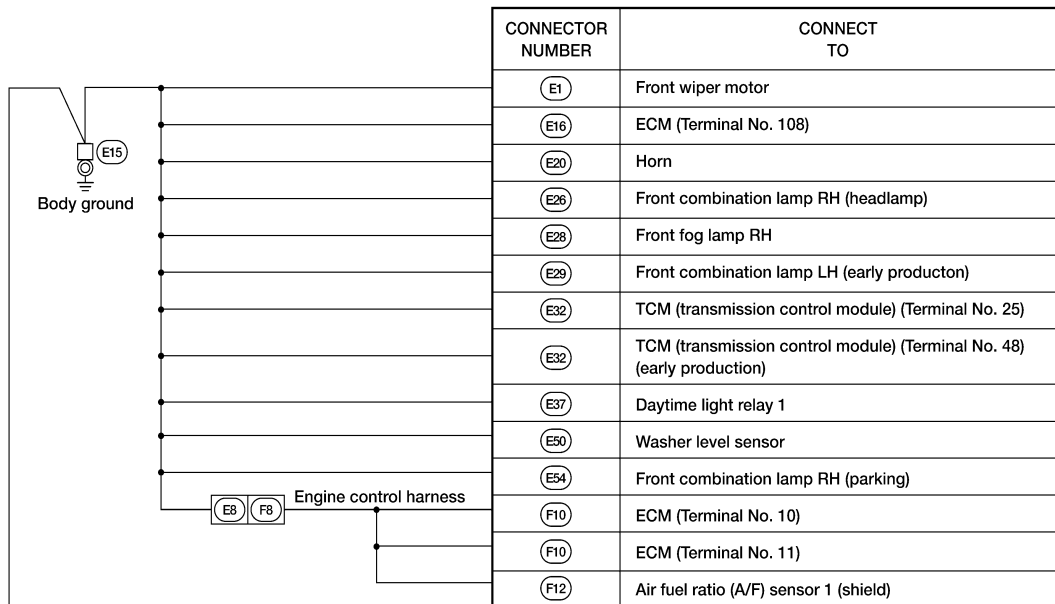
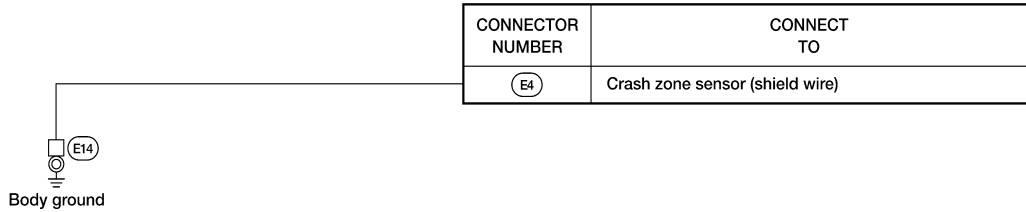
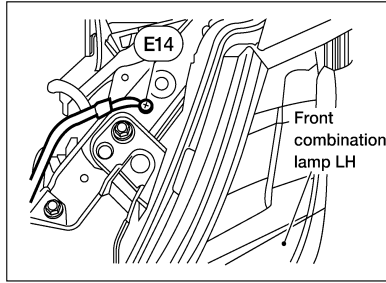
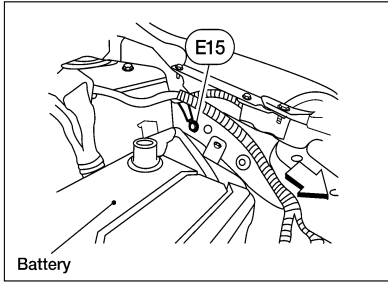

Next page

AAMIA0134GB



# GROUND CIRCUIT

< SERVICE INFORMATION >

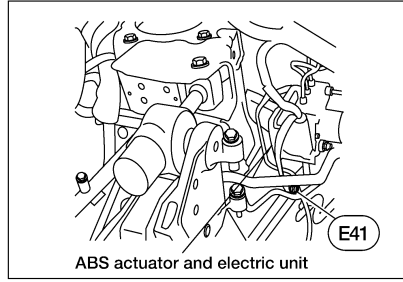
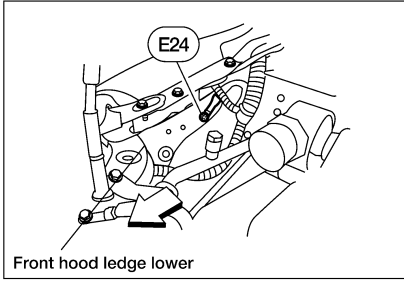

Preceding page

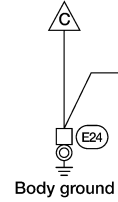

CONNECTOR NUMBER	CONNECT TO
(E3)	Cooling fan motor (Terminal No. 2) (with A/C)
(E3)	Cooling fan motor (Terminal No. 4) (without A/C)
(E25)	Front combination lamp LH (headlamp)
(E27)	Front fog lamp LH
(E29)	Front combination lamp LH (turn signal) (late production)
(E30)	Front combination lamp RH
(E32)	TCM (transmission control module) (Terminal No. 48) (late production)
(E38)	Daytime light relay 2
(E40)	Brake fluid level switch
(E46)	IPDM E/R (intelligent power distribution module engine room) (Terminal No. 39)
(E48)	IPDM E/R (intelligent power distribution module engine room) (Terminal No. 59)
(E53)	Front combination lamp LH (parking)

CONNECTOR NUMBER	CONNECT TO
(E33)	ABS actuator and electric unit (control unit) (Terminal No. 1)
(E33)	ABS actuator and electric unit (control unit) (Terminal No. 4)

AAMIA0150GB

A  
B  
C  
D  
E  
F  
G  
H  
I  
J  
PG  
L  
M  
N  
O  
P

# GROUND CIRCUIT

< SERVICE INFORMATION >

## ENGINE CONTROL HARNESS

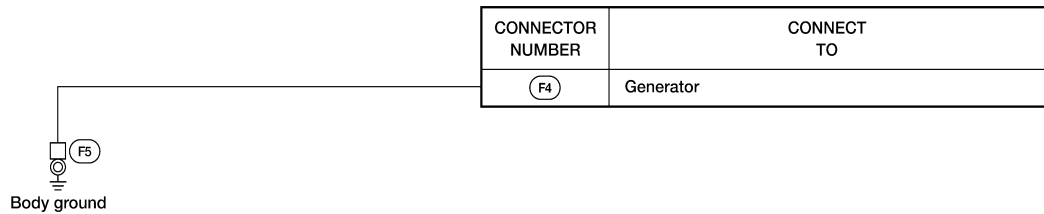
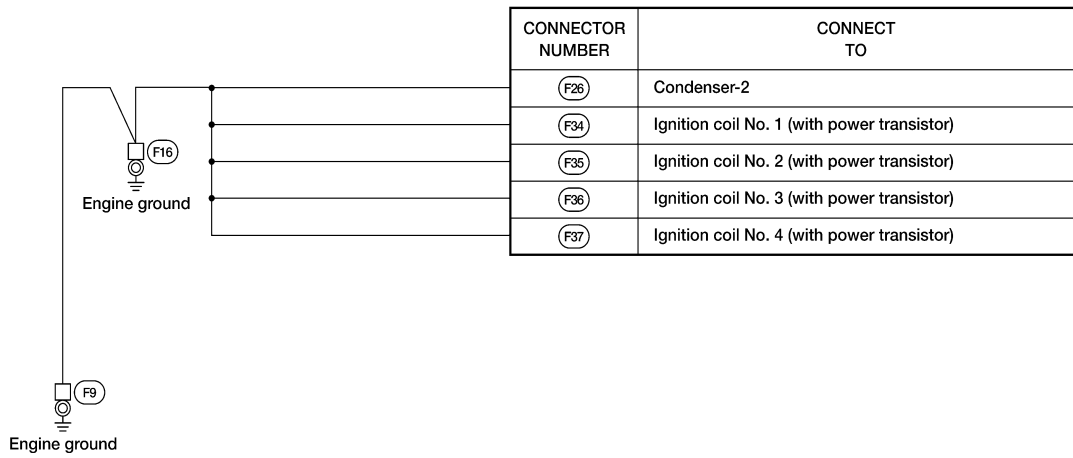
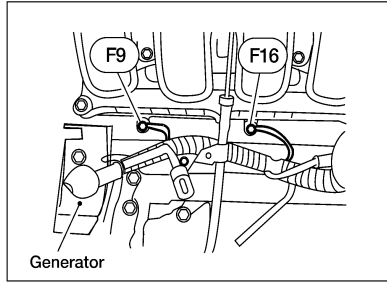
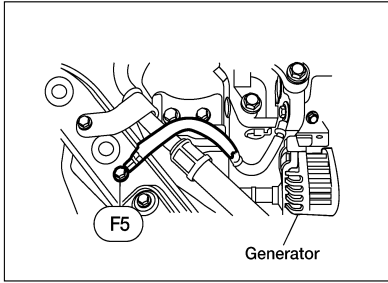

AAMIA0162GB

# GROUND CIRCUIT

< SERVICE INFORMATION >

## BODY HARNESS

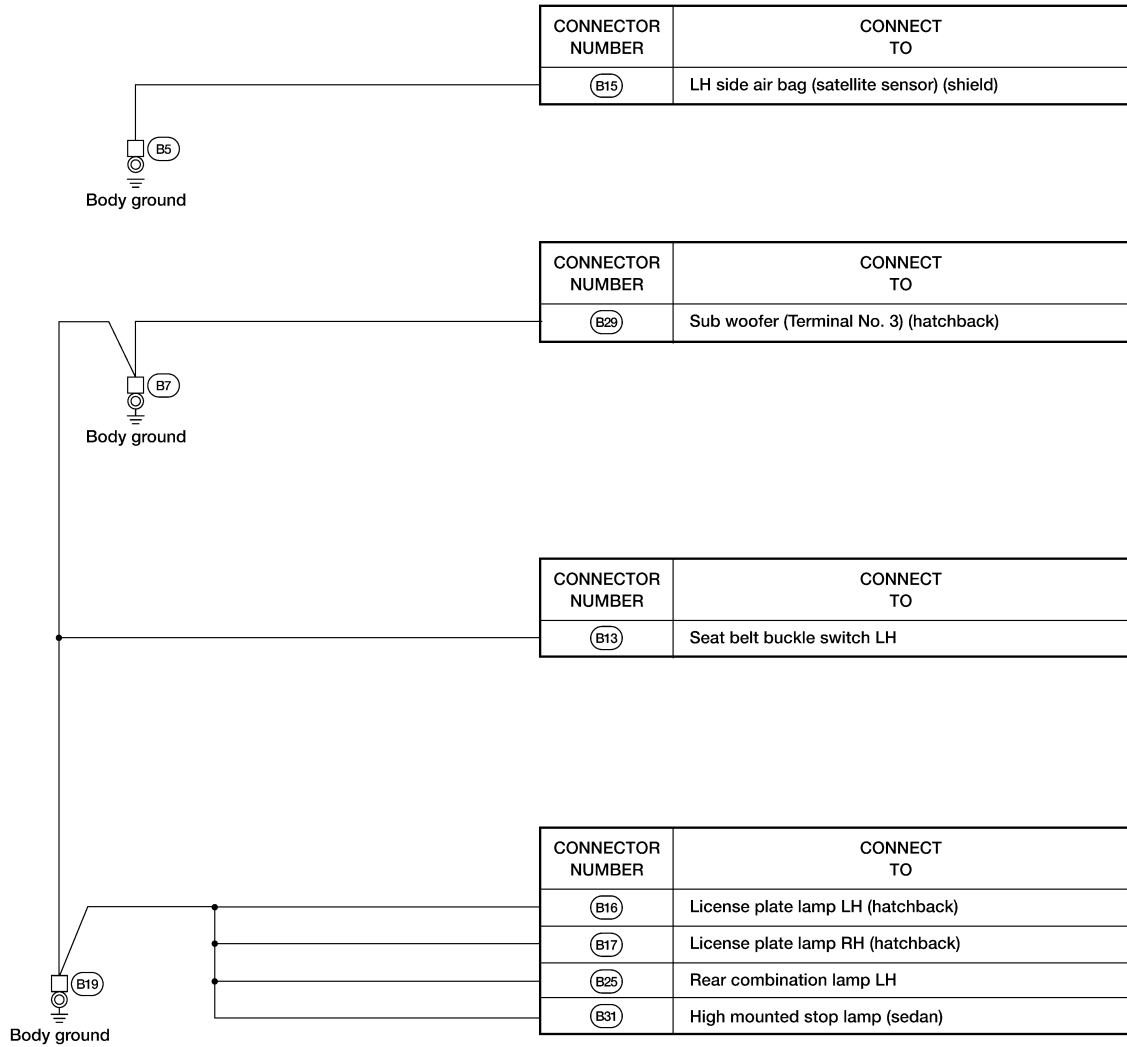
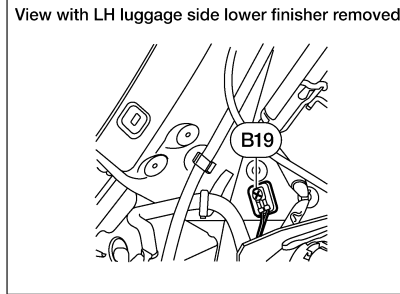
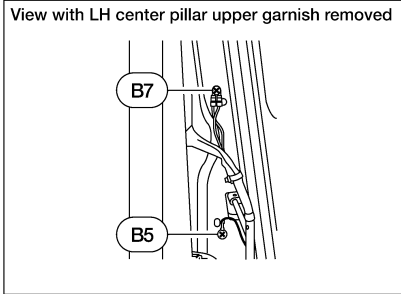

A  
B  
C  
D  
E  
F  
G  
H  
I  
J  
PG  
L  
M  
N  
O  
P

AAMIA0163GB

# GROUND CIRCUIT

< SERVICE INFORMATION >

## BODY NO. 2 HARNESS

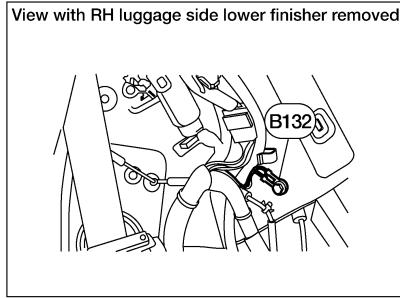
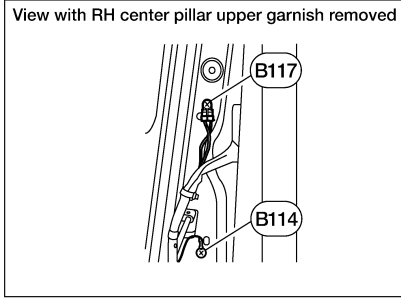

: WITH HATCHBACK

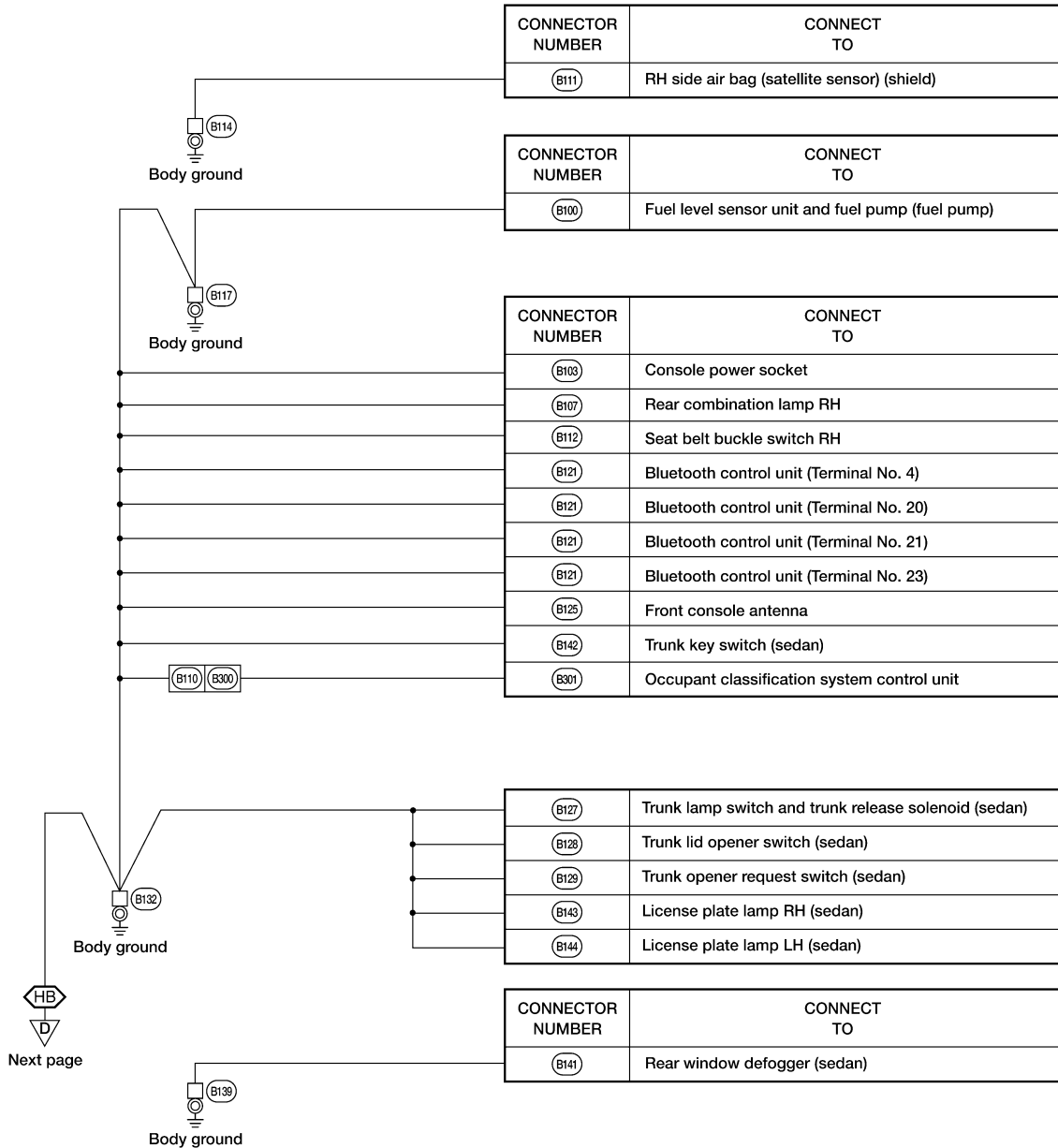

AAMIA0164GB

# GROUND CIRCUIT

< SERVICE INFORMATION >

## BACK DOOR HARNESS (HATCHBACK)

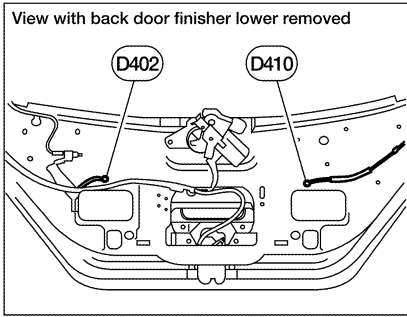

Preceding page

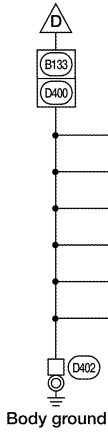

CONNECTOR NUMBER	CONNECT TO
D404	Rear wiper motor
D405	Back door lock assembly (Terminal No. 2)
D405	Back door lock assembly (Terminal No. 4)
D406	Back door request switch
D407	High-mounted stop lamp
D408	Back door opener switch

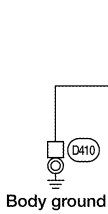

CONNECTOR NUMBER	CONNECT TO
D413	Rear window defogger (hatchback)

A  
B  
C  
D  
E  
F  
G  
H  
I  
J  
PG  
L  
M  
N  
O  
P

WKIA5995E

# HARNESS

< SERVICE INFORMATION >

## HARNESS

### Harness Layout

INFOID:000000004306666

#### HOW TO READ HARNESS LAYOUT

The following Harness Layouts use a map style grid to help locate connectors on the drawings:

- Main Harness
- Engine Room Harness (LH View)
- Engine Room Harness (RH View)
- Engine Control Harness
- Body Harness (Hatchback)
- Body Harness (Sedan)
- Body No. 2 Harness (Hatchback)
- Body No. 2 Harness (Sedan)
- Room Lamp Harness
- Back Door Harness (Hatchback Only)

#### To use the grid reference

1. Find the desired connector number on the connector list.
2. Find the grid reference.
3. On the drawing, find the crossing of the grid reference letter column and number row.
4. Find the connector number in the crossing zone.
5. Follow the line to the connector.

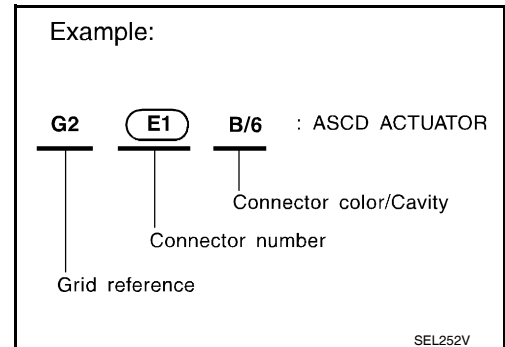

#### OUTLINE

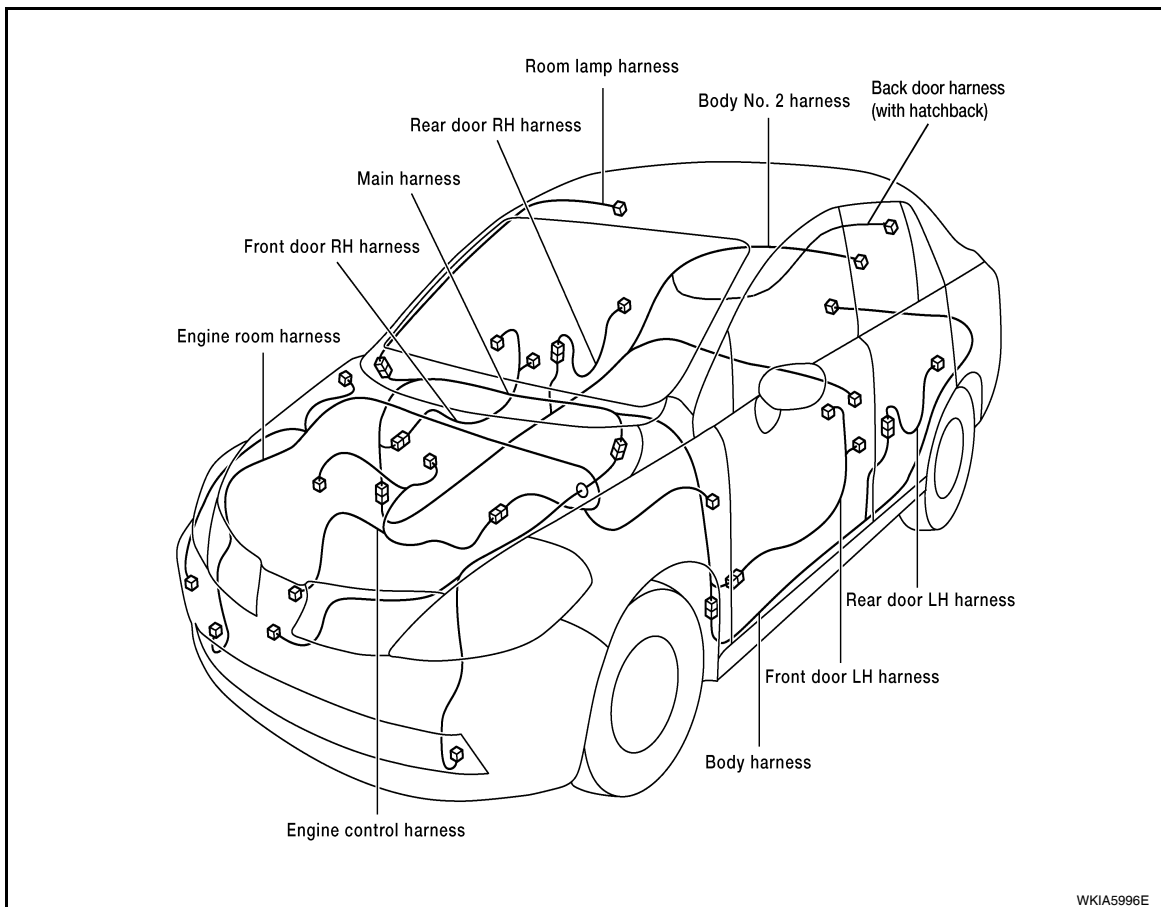

# HARNESS

< SERVICE INFORMATION >

## MAIN HARNESS

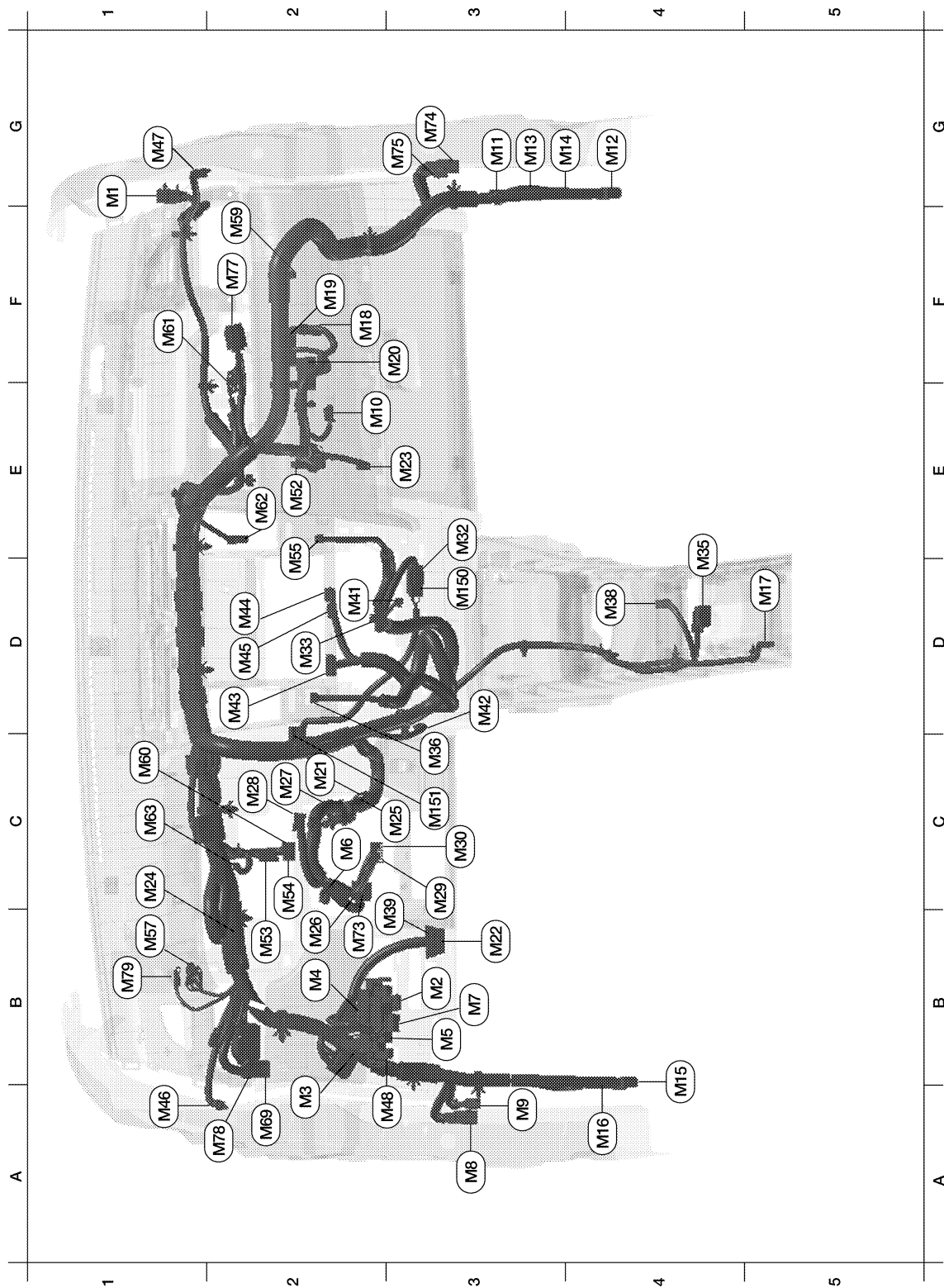

AAMIA0202GB

G1	M1	W/16	: To R1	C3	M36	W/3	: Front passenger air bag OFF indicator
B3	M2	B/5	: Passenger select unlock relay	D4	M38	W/6	: A/T device
B2	M3	W/1	: Fuse block (J/B)	D4	M38	W/6	: CVT device (without intelligent key)
B3	M4	W/1	: Fuse block (J/B)	D4	M38	W/8	: CVT device (with intelligent key)
B3	M5	W/3	: Illumination control switch	B3	M39	W/2	: Tire pressure warning check connector

A  
B  
C  
D  
E  
F  
G  
H  
I  
J  
K  
L  
M  
N  
O  
P

PG

# HARNES

## < SERVICE INFORMATION >

C2	M6	W/4	: Steering lock solenoid	D2	M41	W/2	: Defrost A/C switch
B3	M7	W/16	: Door mirror remote control switch	D3	M42	W/3	: Thermo control amp. (without CVT)
A3	M8	W/16	: To D2	D2	M43	W/20	: Audio unit
A3	M9	W/16	: To D1	D2	M44	W/16	: Audio unit
E2	M10	GR/2	: Instrument panel antenna	D2	M45	W/12	: Audio unit
G3	M11	W/4	: To B106	A1	M46	BR/2	: Front tweeter LH
G4	M12	W/16	: To B101	G1	M47	BR/2	: Front tweeter RH
G3	M13	W/24	: To B102	B2	M48	L/4	: Heated mirror relay
G3	M14	W/24	: To B120	E2	M52	W/40	: Intelligent key unit
B4	M15	W/16	: To B23	B2	M53	W/16	: EPS control unit
B4	M16	W/24	: To B24	B3	M54	B/2	: EPS control unit
D5	M17	B/1	: Parking brake switch	D2	M55†	W/4	: Hazard switch
F2	M18	W/40	: BCM (body control module)	B2	M57	—	: Body ground
F2	M19	W/15	: BCM (body control module)	F2	M59	W/2	: Glove box lamp
F3	M20	B/15	: BCM (body control module)	C1	M60	L/2	: EPS control unit
C2	M21	W/4	: NATS antenna amp.	F1	M61	—	: Body ground
B3	M22	W/16	: Data link connector	E2	M62	W/2	: Front blower motor
E3	M23	W/4	: Remote keyless entry receiver	C1	M63	W/4	: Torque sensor
C1	M24	W/40	: Combination meter	A2	M69	SMJ	: To E7
C3	M25	/2	: Diode-1	B2	M73	GR/6	: Key switch and ignition knob switch
B2	M26	W/6	: Ignition switch	G3	M74	W/12	: To D102
C2	M27	GR/6	: Key switch and key lock solenoid	G3	M75	W/12	: To D101
C2	M28	W/16	: Combination switch	F2	M77	Y/4	: Front passenger air bag module
C3	M29	Y/6	: Combination switch	A2	M78	B/2	: To E11
C3	M30	GR/8	: Combination switch	B1	M79	—	: Body ground
E3	M32	W/4	: To M150	D3	M150	W/4	: To M32
D2	M33	B/15	: Front air control	C3	M151	W/4	: Front blower motor resistor
D4	M35	Y/28	: Air bag diagnosis sensor unit				



# HARNESS

< SERVICE INFORMATION >

## ENGINE ROOM HARNESS (LH VIEW)

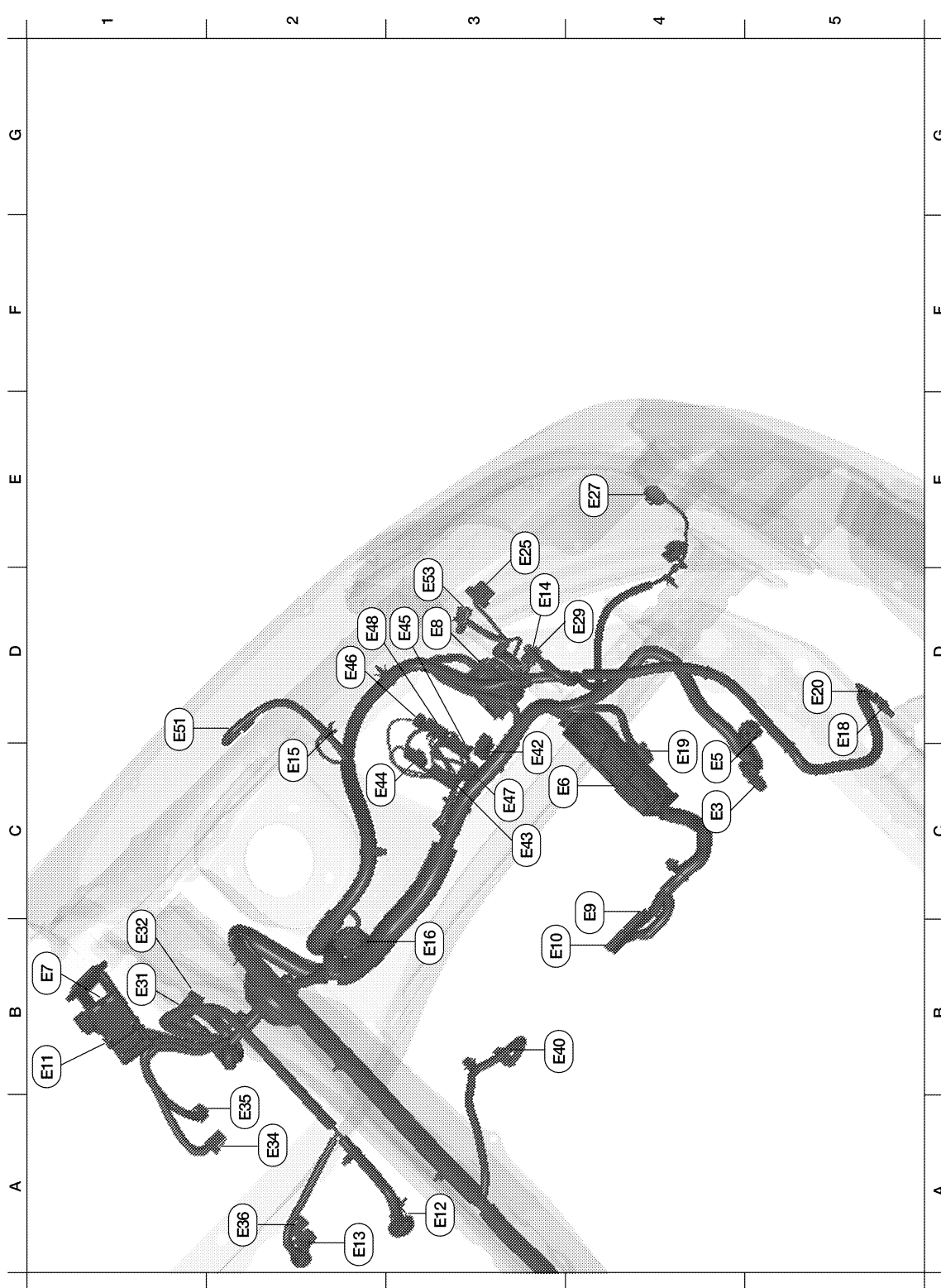

AAMIA0136GB

Refer to "ENGINE ROOM HARNESS (RH VIEW)" for continuation of engine room harness.

C4	E3	GR/4	: Cooling fan motor (without A/C)	D3	E25	B/3	: Front combination lamp LH (headlamp)
C4	E3	B/2	: Cooling fan motor (with A/C)	E4	E27	B/2	: Front fog lamp LH
C4	E5	GR/3	: Resistor	D4	E29	B/2	: Front combination lamp LH (turn signal)
C3	E6	—	: Fuse and fusible link box	B1	E31	W/24	: TCM
B1	E7	SMJ	: To M69	B1	E32	GR/24	: TCM

# HARNES

## < SERVICE INFORMATION >

D3	E8	SMJ	: To F8	A2	E34	BR/2	: Clutch interlock switch (with M/T)
B4	E9	BR/2	: Fusible link box (battery)	A2	E35	BR/2	: ASCD clutch switch
B3	E10	GR/2	: Fusible link box (battery)	A2	E36	BR/2	: ASCD brake switch
B1	E11	B/2	: To M78	B4	E40	GR/2	: Brake fluid level switch
A3	E12	B/6	: Accelerator pedal position sensor	D3	E42	B/2	: IPDM E/R (intelligent power distribution module engine room)
A2	E13	B/2	: Stop lamp switch (with M/T)	C3	E43	W/16	: IPDM E/R (intelligent power distribution module engine room)
A2	E13	W/4	: Stop lamp switch (without M/T)	C3	E44	W/6	: IPDM E/R (intelligent power distribution module engine room)
D3	E14	—	: Engine ground (crash zone sensor)	D3	E45	BR/12	: IPDM E/R (intelligent power distribution module engine room)
C2	E15	—	: Engine ground	D3	E46	W/12	: IPDM E/R (intelligent power distribution module engine room)
B2	E16	B/32	: ECM	C3	E47	BR/8	: IPDM E/R (intelligent power distribution module engine room)
C5	E18	B/1	: Horn	D3	E48	B/6	: IPDM E/R (intelligent power distribution module engine room)
C4	E19	GR/6	: To F33	D1	E51	B/2	: Front wheel sensor LH
D5	E20	B/1	: Horn	D3	E53	B/2	: Front combination lamp LH (parking)

# HARNESS

< SERVICE INFORMATION >

## ENGINE ROOM HARNESS (RH VIEW)

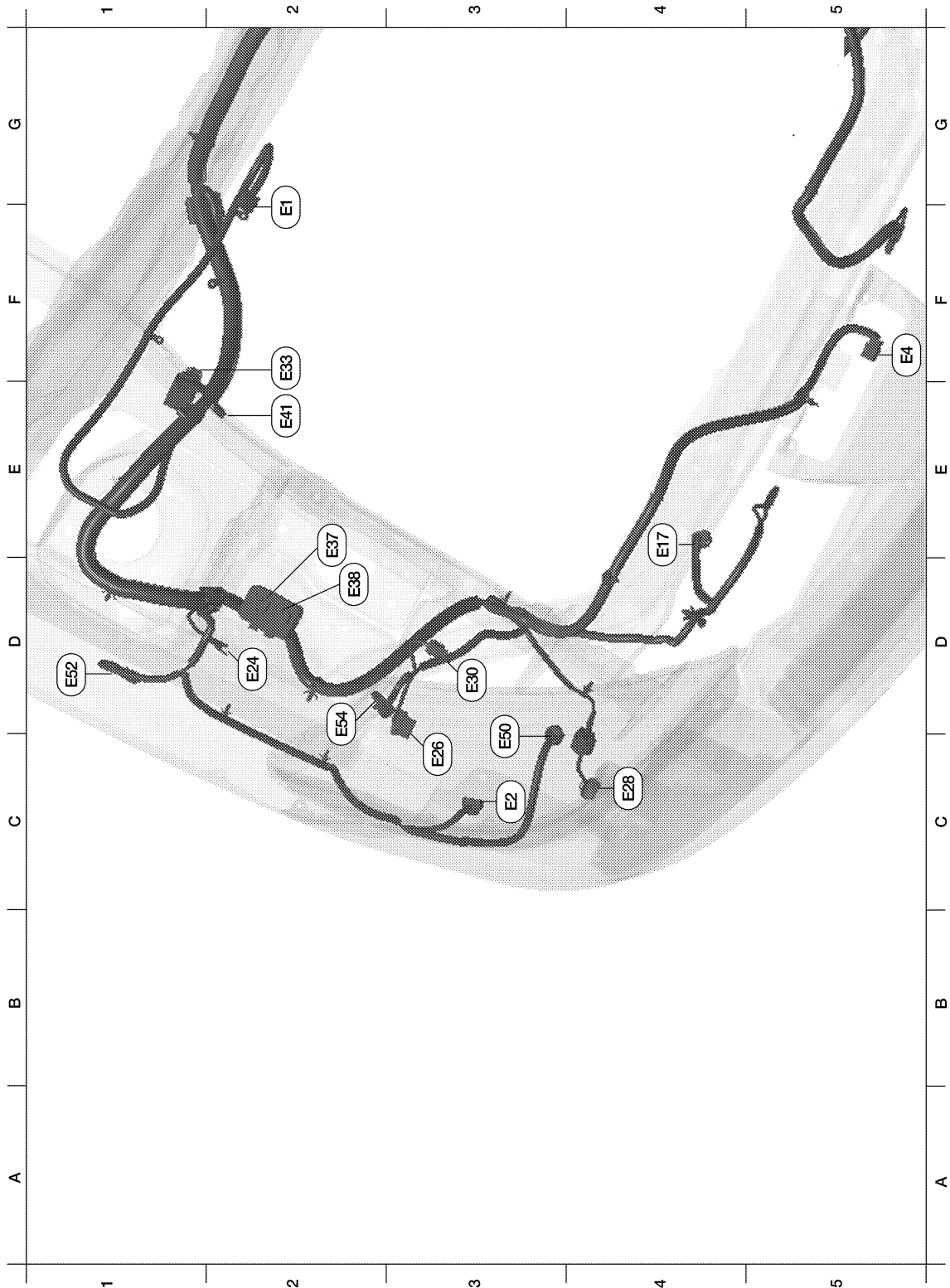

AAMIA0137GB

Refer to "ENGINE ROOM HARNESS (LH VIEW)" for continuation of engine room harness.

G2	E1	GR/5	: Front wiper motor	F2	E33	B/26	: ABS actuator and electric unit (control unit)
C3	E2	B/2	: Front and rear washer motor	E2	E37	B/5	: Daytime light relay 1
F5	E4	Y/2	: Crash zone sensor	D2	E38	L/5	: Daytime light relay 2
E4	E17	B/3	: Refrigerant pressure sensor	E2	E41	—	: Ground (ABS)
D2	E24	—	: Engine ground	C3	E50	W/2	: Washer fluid level switch

# HARNESS

## < SERVICE INFORMATION >

C3	E26	B/3	: Front combination lamp RH (headlamp)	D1	E52	B/2	: Front wheel sensor RH
C4	E28	B/2	: Front fog lamp RH	D2	E54	B/2	: Front combination lamp RH (parking)
D3	E30	B/2	: Front combination lamp RH (turn signal)				

## ENGINE CONTROL HARNESS

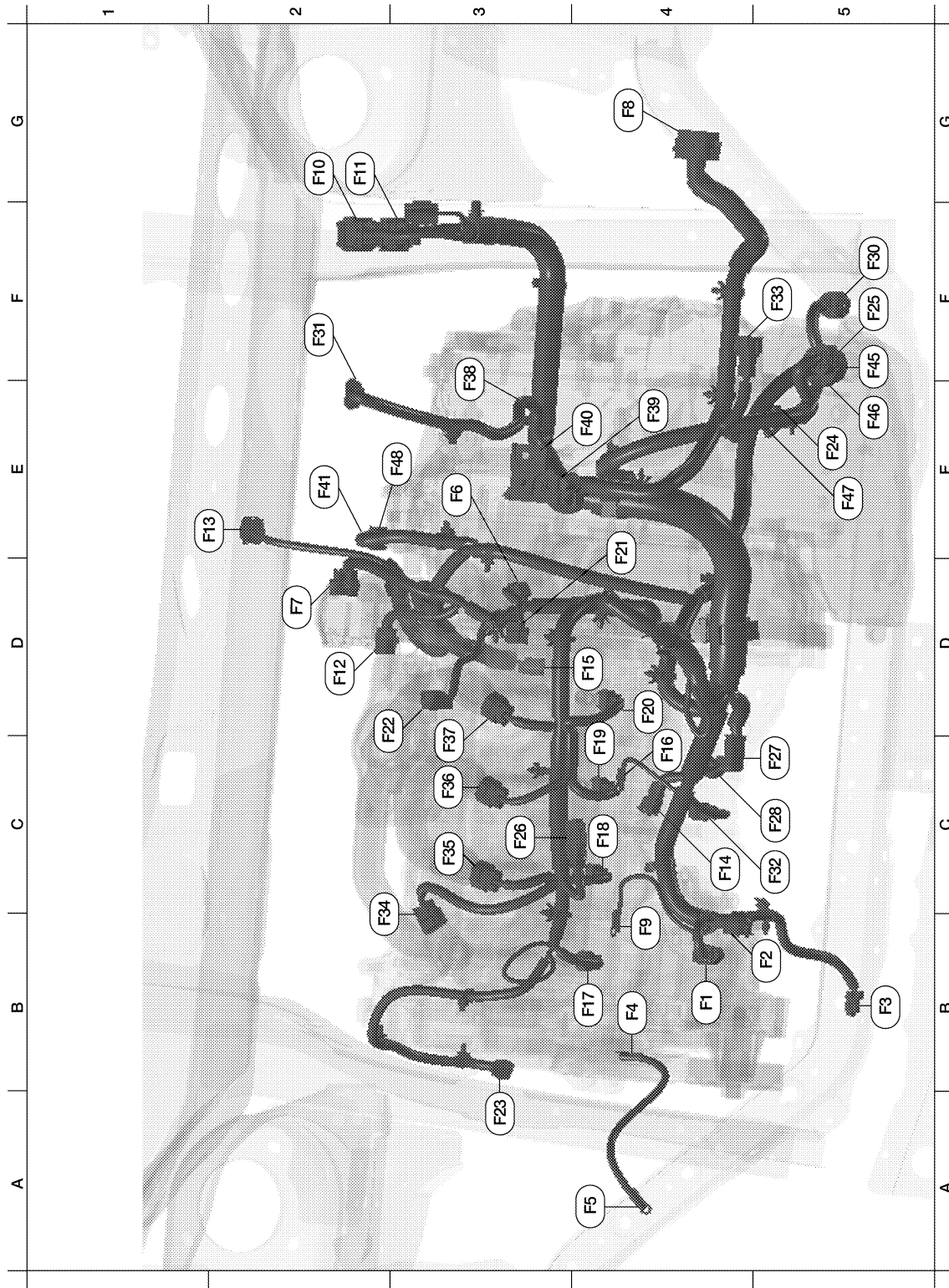

AAMIA0138GB

B4	F1	B/3	: Generator	B3	F23	GR/2	: Intake valve timing control solenoid valve
B5	F2	—	: Generator	E5	F24	G/3	: Park/neutral position (PNP) switch (with M/T)

# HARNESS

## < SERVICE INFORMATION >

B5	F3	B/1	: A/C compressor	F5	F25	B/10	: Park/neutral position (PNP) switch (with A/T)
B4	F4	—	: Generator	C3	F26	W/2	: Condenser-2
A4	F5	—	: Generator ground	C5	F27	—	: Starter motor
E3	F6	GR/2	: Engine coolant temperature sensor	C5	F28	—	: Starter motor
D2	F7	B/6	: Electric throttle control actuator	F5	F30	B/8	: Terminal cord assembly
G4	F8	SMJ	: To E8	F2	F31	B/6	: Mass air flow sensor
B4	F9	—	: Engine ground	C5	F32	GR/1	: Oil pressure switch
G2	F10	GR/32	: ECM	F5	F33	GR/6	: To E19
G2	F11	BR/48	: ECM	C3	F34	GR/3	: Ignition coil No. 1 (with power transistor)
D3	F12	GR/4	: Air fuel ratio (A/F) sensor 1	C3	F35	GR/3	: Ignition coil No. 2 (with power transistor)
E2	F13	B/4	: Heated oxygen sensor 2	C3	F36	GR/3	: Ignition coil No. 3 (with power transistor)
C4	F14	B/2	: Knock sensor	C3	F37	GR/3	: Ignition coil No. 4 (with power transistor)
D3	F15	B/3	: Crankshaft position sensor (POS)	E5	F38	BR/3	: Revolution sensor
C4	F16	—	: Engine ground	E4	F39	—	: Fusible link box (battery)
B4	F17	GR/2	: Fuel injector No. 1	E4	F40	—	: Fusible link box (battery)
C4	F18	GR/2	: Fuel injector No. 2	E2	F41	GR/2	: Vehicle speed sensor
C4	F19	GR/2	: Fuel injector No. 3	F5	F45	GR/3	: Turbine revolution sensor
D4	F20	GR/2	: Fuel injector No. 4	E5	F46	GR/22	: CVT unit
D4	F21	B/3	: Camshaft position sensor (PHASE)	E5	F47	B/3	: Powertrain revolution sensor (with A/T)
C3	F22	GR/2	: EVAP canister purge volume control solenoid valve	E3	F48	B/3	: Secondary speed sensor (with M/T)

## BODY HARNESS (HATCHBACK)

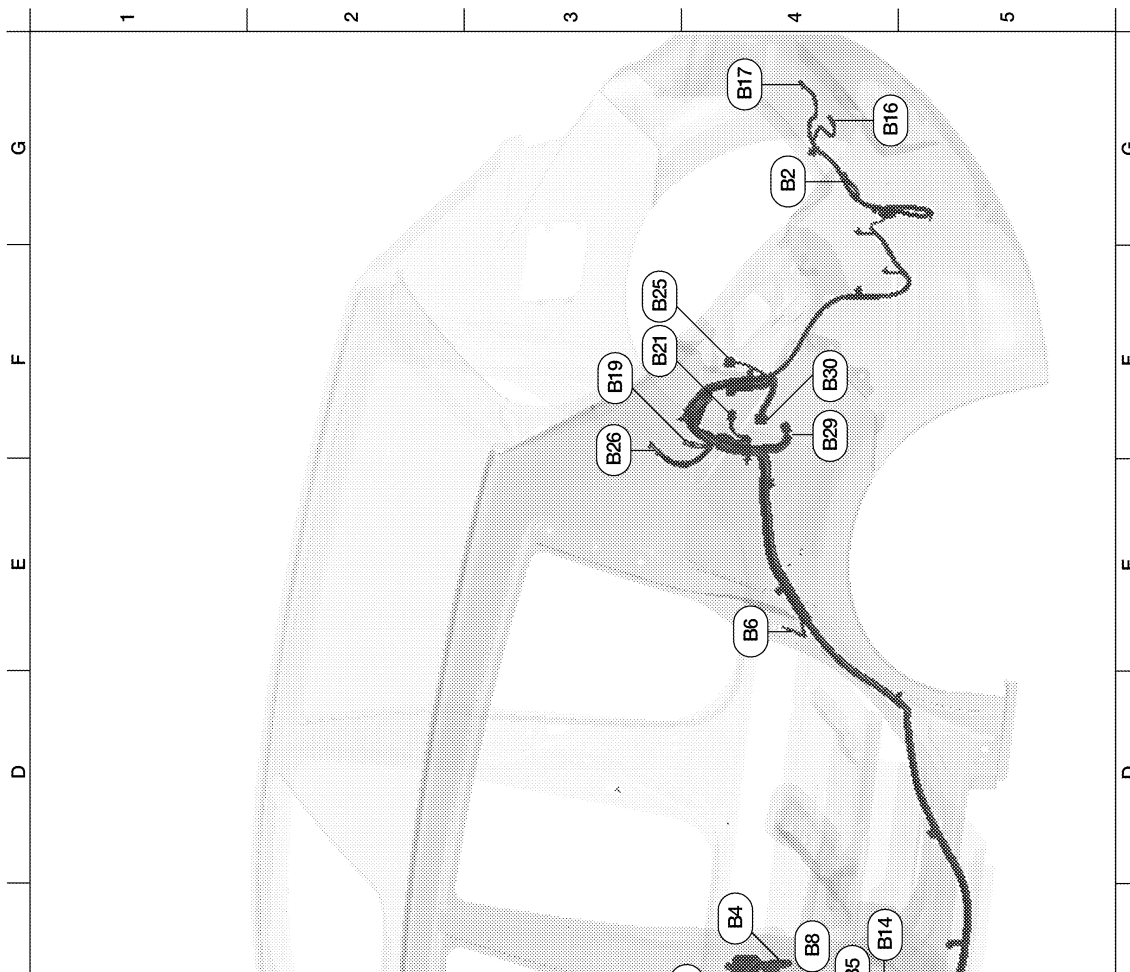

A  
B  
C  
D  
E  
F  
G  
H  
I  
J  
L  
M  
N  
O  
P

PG

# HARNESS

## < SERVICE INFORMATION >

G4	B2	GR/2	: Rear bumper antenna	G4	B16	BR/2	: License plate lamp LH
C4	B4	W/8	: To D201	G4	B17	BR/2	: License plate lamp RH
C4	B5	—	: Body ground	F3	B19	—	: Body ground
E4	B6	W/1	: Rear door switch LH	F3	B21	W/2	: Luggage room lamp
C4	B7	—	: Body ground	A4	B23	W/16	: To M15
C4	B8	W/3	: Front door switch LH	A4	B24	W/24	: To M16
C4	B9	Y/12	: Air bag diagnosis sensor unit	F3	B25	BR/6	: Rear combination lamp LH
C4	B10	Y/2	: Front LH side air bag module	F3	B26	Y/2	: LH side curtain air bag module
F3	B13	W/3	: Seat belt buckle switch LH	F4	B29	W/6	: Subwoofer
C4	B14	Y/2	: Front LH seat belt pre-tensioner	F4	B30	W/16	: Satellite radio tuner
C5	B15	Y/2	: LH side air bag (satellite) sensor				

# HARNESS

< SERVICE INFORMATION >

## BODY HARNESS (SEDAN)

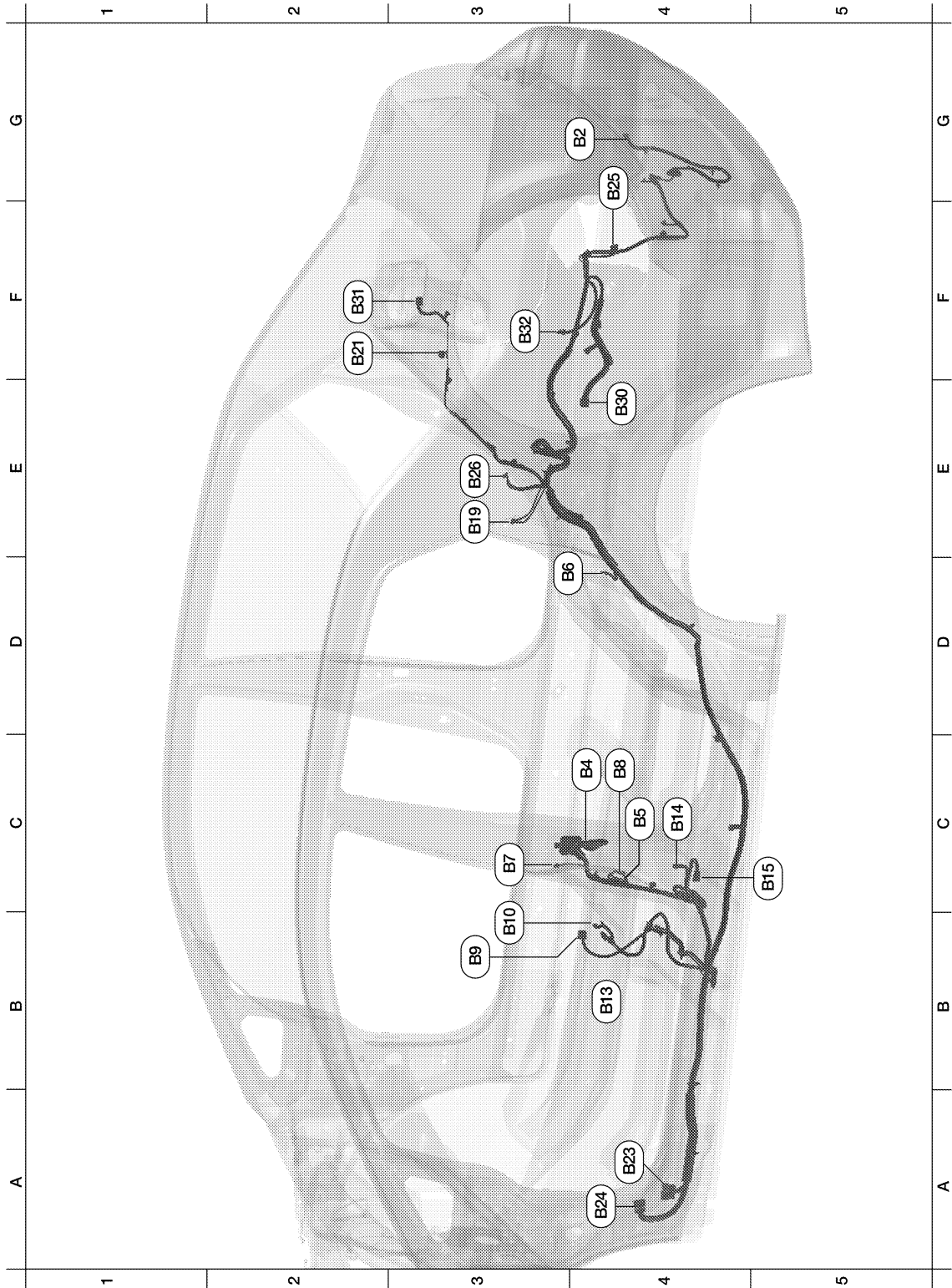

AAMIA0140GB

G4	B2	GR/2	: Rear bumper antenna	C5	B15	Y/2	: LH side air bag (satellite) sensor
C4	B4	W/8	: To D201	E3	B19	—	: Body ground
C4	B5	—	: Body ground	F2	B21	W/2	: Luggage room lamp
D3	B6	W/1	: Rear door switch LH	A4	B23	W/16	: To M15
C3	B7	—	: Body ground	A4	B24	W/24	: To M16

A  
B  
C  
D  
E  
F  
G  
H  
I  
J  
K  
L  
M  
N  
O  
P

# HARNESS

## < SERVICE INFORMATION >

C4	B8	W/3	: Front door switch LH	G4	B25	BR/6	: Rear combination lamp LH
B3	B9	Y/12	: Air bag diagnosis sensor unit	E3	B26	Y/2	: LH side curtain air bag module
B3	B10	Y/2	: Front LH side air bag module	E4	B30	W/16	: Satellite radio tuner
B4	B13	W/3	: Seat belt buckle switch LH	F2	B31	W/2	: High mounted stop lamp
C4	B14	Y/2	: Front LH seat belt pre-tensioner	F3	B32	BR/2	: Intelligent key warning buzzer (trunk)

## BODY NO. 2 HARNESS (HATCHBACK)

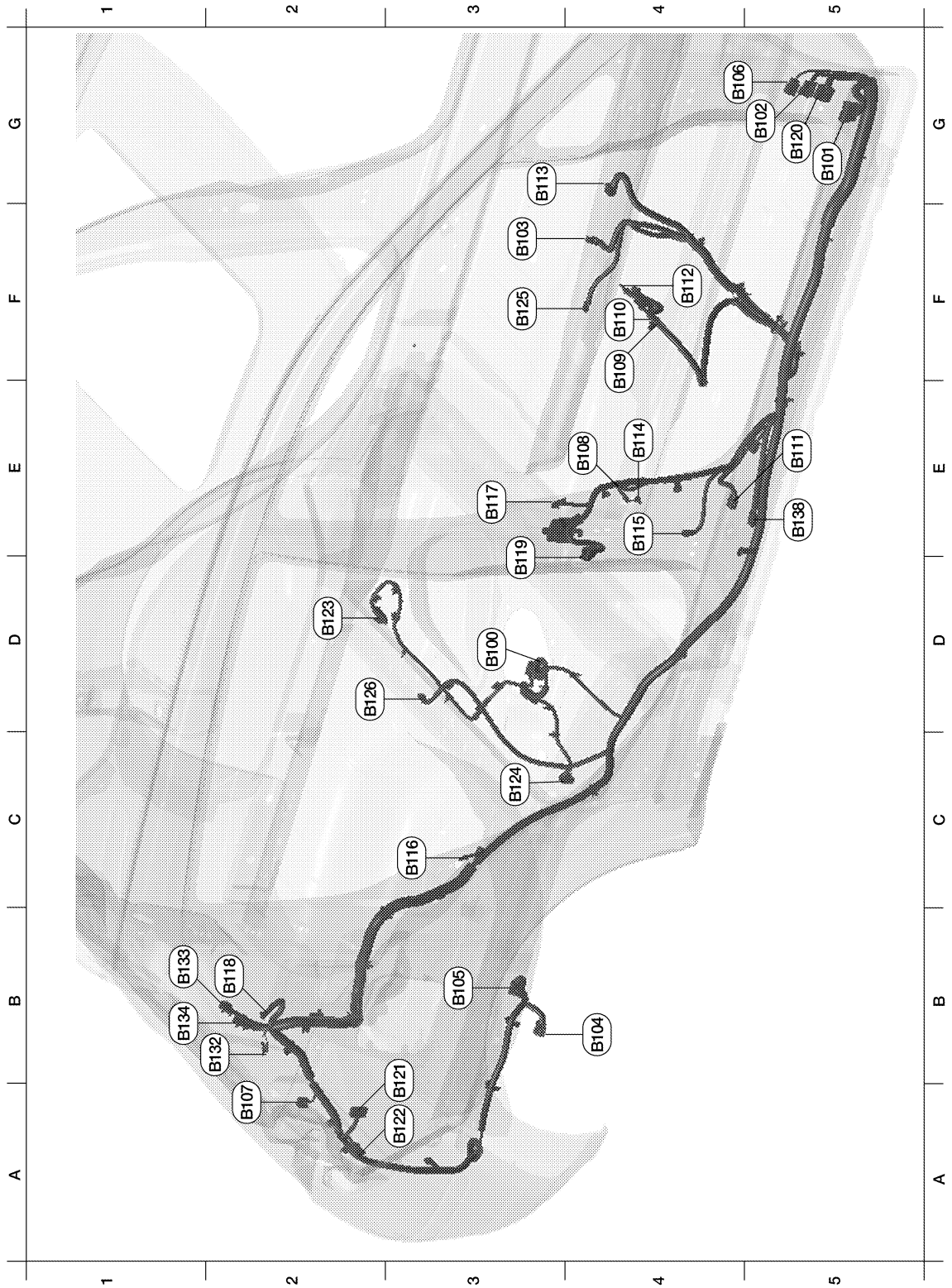

AAMIA0141GB



# HARNES

## < SERVICE INFORMATION >

D3	B100	GR/5	: Fuel level sensor unit and fuel pump	C3	B116	W/1	: Rear door switch RH
G5	B101	W/16	: To M12	E3	B117	—	: Body ground
G5	B102	W/24	: To M13	B2	B118	Y/2	: RH side curtain air bag module
F3	B103	B/2	: Console power socket	D3	B119	W/8	: To D301
A4	B104	GR/3	: EVAP control system pressure sensor	G5	B120	W/24	: To M14
A3	B105	B/2	: EVAP canister vent control valve	A3	B121	W/32	: Bluetooth control unit
G5	B106	W/4	: To M11	A3	B122	GR/1	: Bluetooth control unit
A2	B107	BR/6	: Rear combination lamp RH	D2	B123	B/2	: Rear wheel sensor LH
E4	B108	W/3	: Front door switch RH	C3	B124	B/2	: Rear wheel sensor RH
F4	B109	Y/2	: Front RH side air bag module	F3	B125	GR/2	: Front console antenna
F4	B110	W/10	: To B300	C3	B126	GR/2	: Rear floor antenna
E5	B111	Y/2	: RH side air bag (satellite) sensor	A2	B132	—	: Body ground
F4	B112	W/3	: Seat belt buckle switch RH	B2	B133	W/2	: To D400
F3	B113	Y/12	: Air bag diagnosis sensor unit	A2	B134	W/12	: To D401
E4	B114	—	: Body ground	E5	B138	B/3	: Belt tension sensor
E4	B115	Y/2	: Front RH seat belt pre-tensioner				

A  
B  
C  
D  
E  
F  
G  
H  
I  
J  
L  
M  
N  
O  
P

PG

# HARNESS

< SERVICE INFORMATION >

BODY NO. 2 HARNESS (SEDAN)

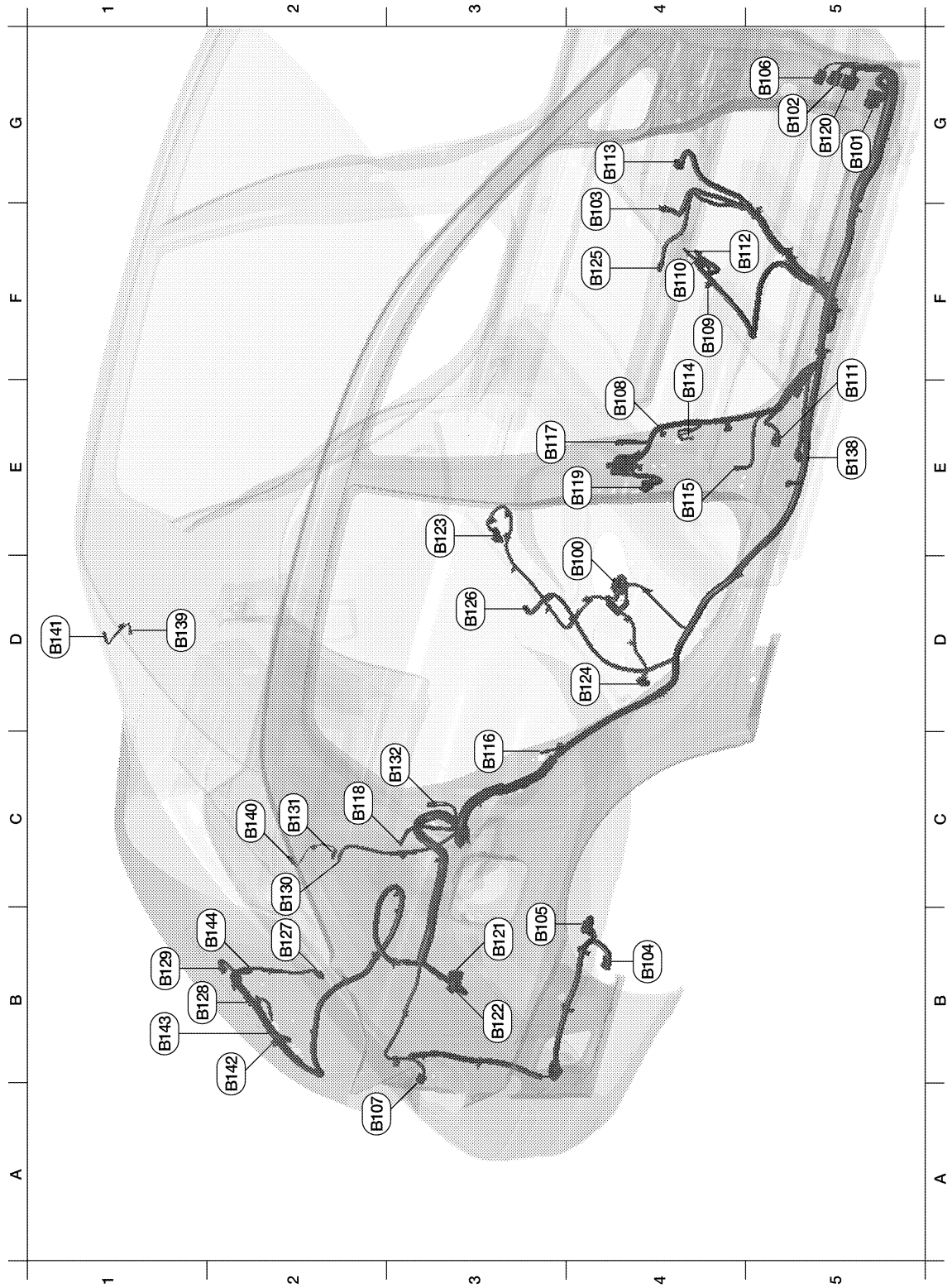

AAMIA0142GB

E3	B100	GR/5	: Fuel level sensor unit and fuel pump	G5	B120	W/24	: To M14
G5	B101	W/16	: To M12	C3	B121	W/32	: Bluetooth control unit
G5	B102	W/24	: To M13	B3	B122	GR/1	: Bluetooth control unit
F4	B103	B/2	: Console power socket	E3	B123	B/2	: Rear wheel sensor LH
B4	B104	GR/3	: EVAP control system pressure sensor	D4	B124	B/2	: Rear wheel sensor RH

# HARNESS

## < SERVICE INFORMATION >

B3	B105	B/2	: EVAP canister vent control valve	F4	B125	GR/2	: Front console antenna
G5	B106	W/4	: To M11	D3	B126	GR/2	: Rear floor antenna
A2	B107	BR/6	: Rear combination lamp RH	B2	B127	W/3	: Trunk lamp switch and trunk release solenoid
F4	B108	W/3	: Front door switch RH	B1	B128	BR/2	: Trunk lid opener switch
F4	B109	Y/2	: Front RH side air bag module	B1	B129	GR/2	: Trunk opener request switch
F4	B110	W/10	: To B300	C2	B130	B/1	: Condenser-1
E5	B111	Y/2	: RH side air bag (satellite) sensor	C2	B131	B/1	: Condenser-1
F4	B112	W/3	: Seat belt buckle switch RH	C3	B132	—	: Body ground
G3	B113	Y/12	: Air bag diagnosis sensor unit	E5	B138	B/3	: Belt tension sensor
E4	B114	—	: Body ground	D1	B139	—	: Body ground
E4	B115	Y/2	: Front RH seat belt pre-tensioner	C2	B140	B/1	: Rear window defogger (+)
C3	B116	W/1	: Rear door switch RH	D1	B141	B/1	: Rear window defogger (-)
E3	B117	—	: Body ground	B2	B142	W/3	: Trunk key cylinder switch
C2	B118	Y/2	: RH side curtain air bag module	B1	B143	BR/2	: License plate lamp RH
E4	B119	W/8	: To D301	B2	B144	BR/2	: License plate lamp LH

## ROOM LAMP HARNESS

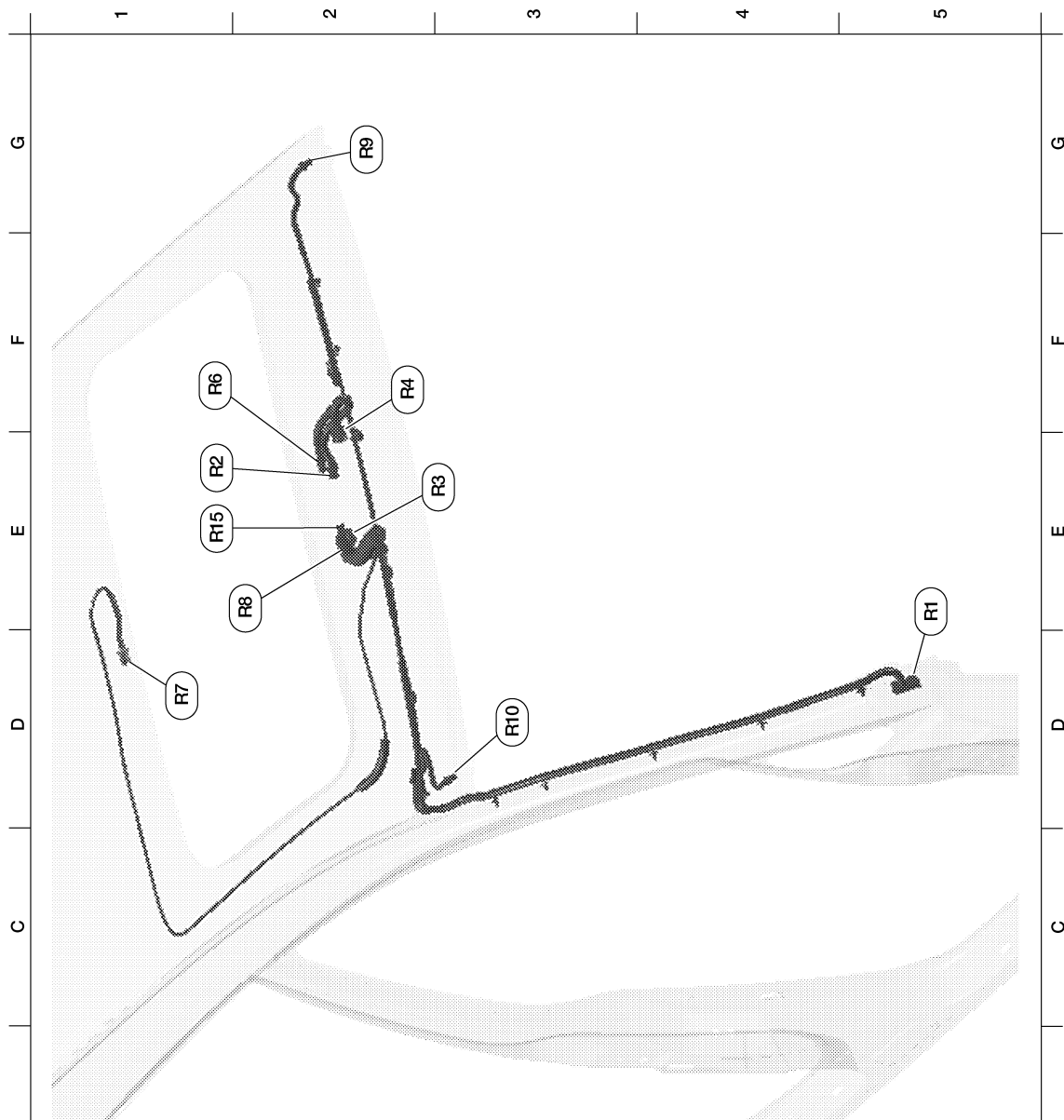

A  
B  
C  
D  
E  
F  
G  
H  
I  
J  
L  
M  
N  
O  
P

# HARNESS

## < SERVICE INFORMATION >

D5	R1	W/16	: To M1	D1	R7	W/3	: Interior room lamp
F2	R2	GR/4	: Map lamp	E2	R8	W/3	: To R50 (without map lamps)
F2	R3	W/3	: Map lamp	G2	R9	W/2	: Vanity mirror lamp LH
F2	R4	GR/10	: Sunroof motor assembly	D3	R10	W/2	: Vanity mirror lamp RH
F2	R6	W/3	: Sunroof switch	D1	R15	W/8	: Microphone

## FRONT DOOR LH HARNESS

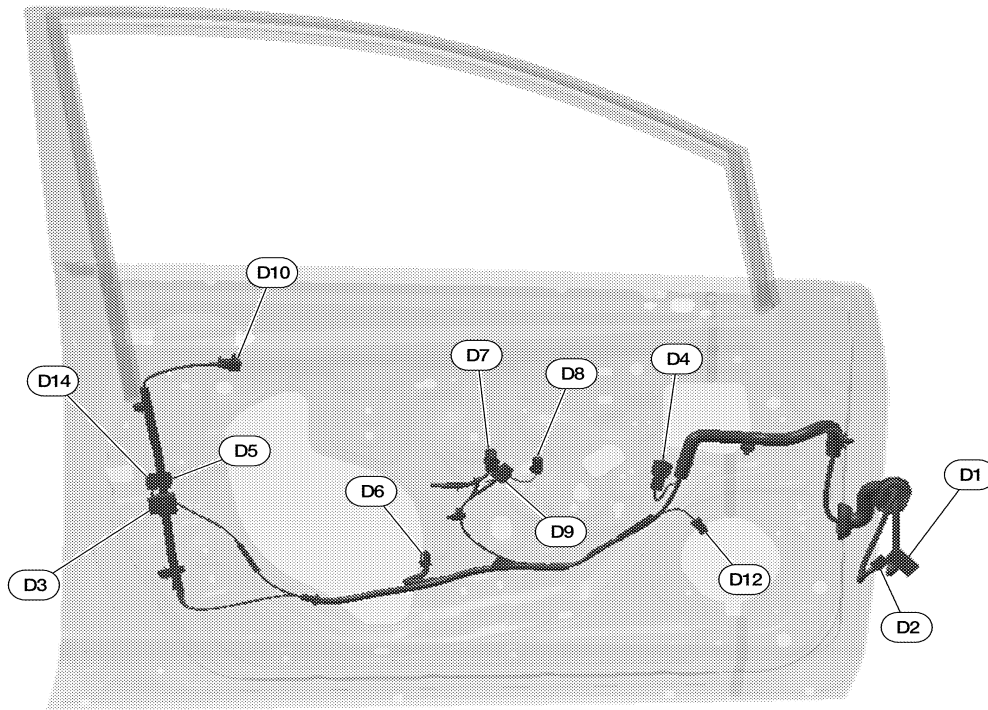

D1	W/16	: To M9	D7	W/16	: Main power window and door lock/unlock switch
D2	W/16	: To M8	D8	W/3	: Main power window and door lock/unlock switch
D3	B/6	: Front door lock actuator LH	D9	B/6	: Front power window motor LH
D4	BR/8	: Door mirror LH	D10	GR/2	: Front outside antenna LH
D5	GR/2	: Front door request switch LH	D12	W/2	: Front door speaker LH
D6	BR/2	: Intelligent key warning buzzer (front door LH)	D14	BR/3	: Front door key cylinder switch LH

# HARNESS

## < SERVICE INFORMATION > FRONT DOOR RH HARNESS

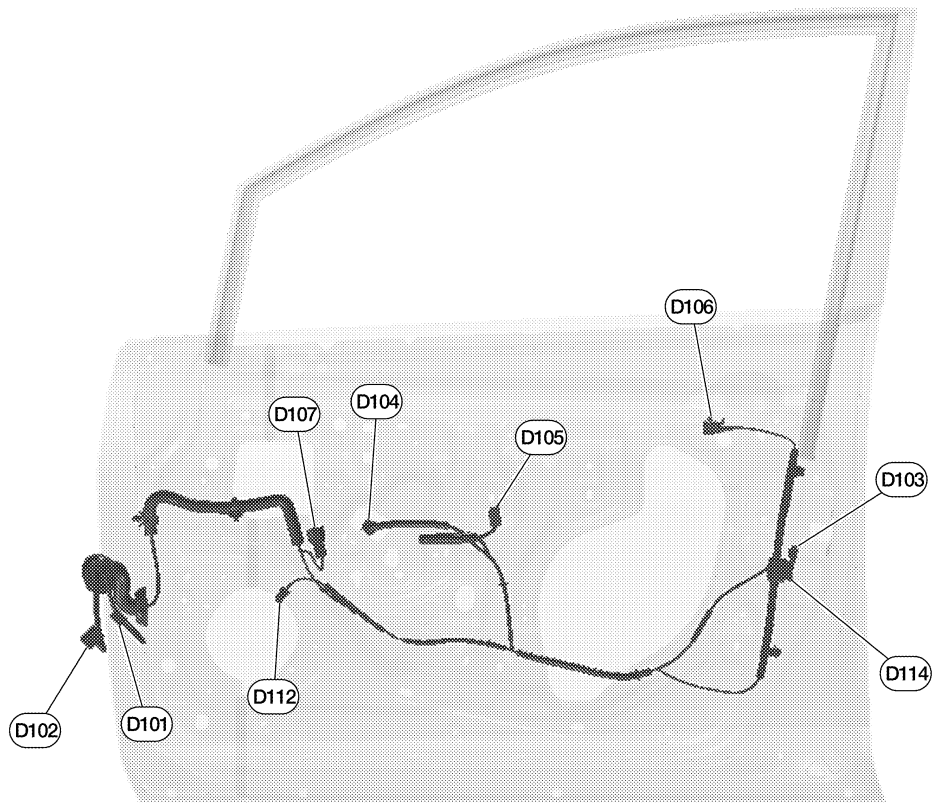

LKIA0822E

D101	W/12	: To M75	D106	GR/2	: Front outside antenna RH
D102	W/12	: To M74	D107	BR/8	: Door mirror RH
D103	GR/2	: Front door request switch RH	D112	W/2	: Front door speaker RH
D104	BR/2	: Front power window motor RH	D114	B/6	: Front door lock actuator RH
D105	W/12	: Power window and door lock/unlock switch RH			

A  
B  
C  
D  
E  
F  
G  
H  
I  
J  
PG  
L  
M  
N  
O  
P

# HARNESS

< SERVICE INFORMATION >

## REAR DOOR LH HARNESS

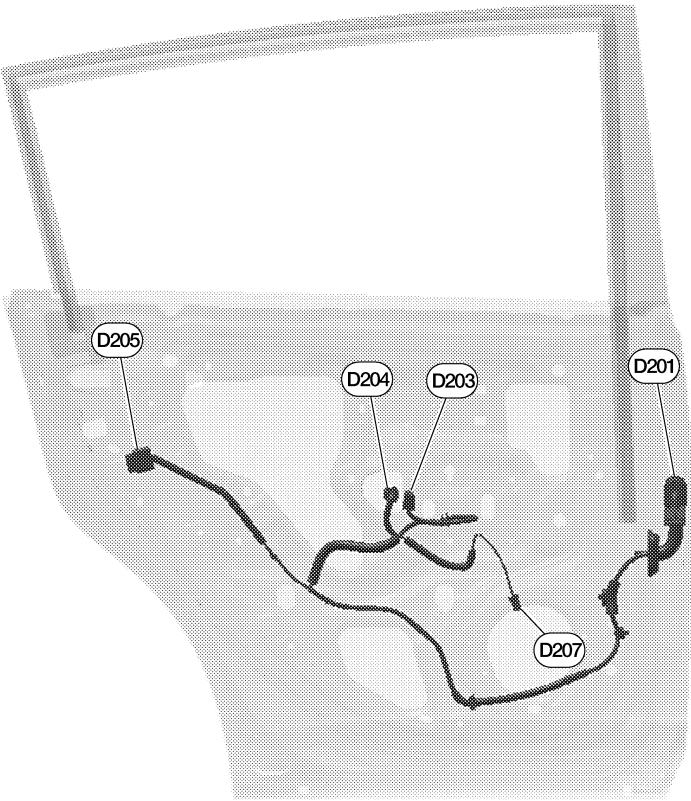

LKIA0824E

D201	W/8	: To B4	D205	B/6	: Rear door lock actuator LH
D203	W/8	: Rear power window switch LH	D207	W/2	: Rear door speaker LH
D204	BR/2	: Rear power window motor LH			

# HARNESS

< SERVICE INFORMATION >

## REAR DOOR RH HARNESS

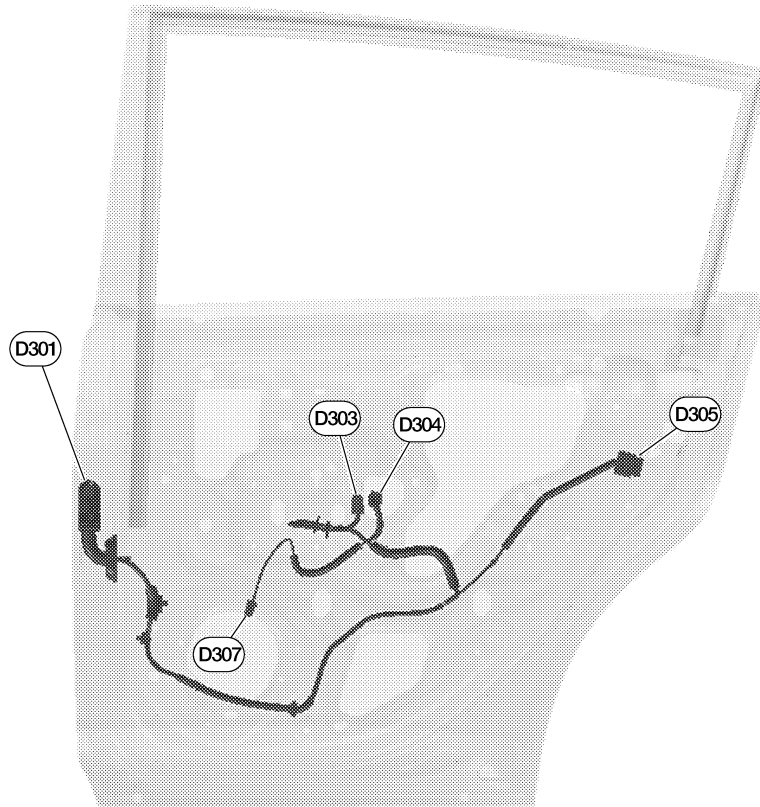

LKIA0823E

D301	W/8	: To B119	D305	B/6	: Rear door lock actuator RH
D303	W/8	: Rear power window switch RH	D307	W/2	: Rear door speaker RH
D304	BR/2	: Rear power window motor RH			

A  
B  
C  
D  
E  
F  
G  
H  
I  
J  
PG  
L  
M  
N  
O  
P

# HARNESS

< SERVICE INFORMATION >

## BACK DOOR HARNESS (HATCHBACK ONLY)

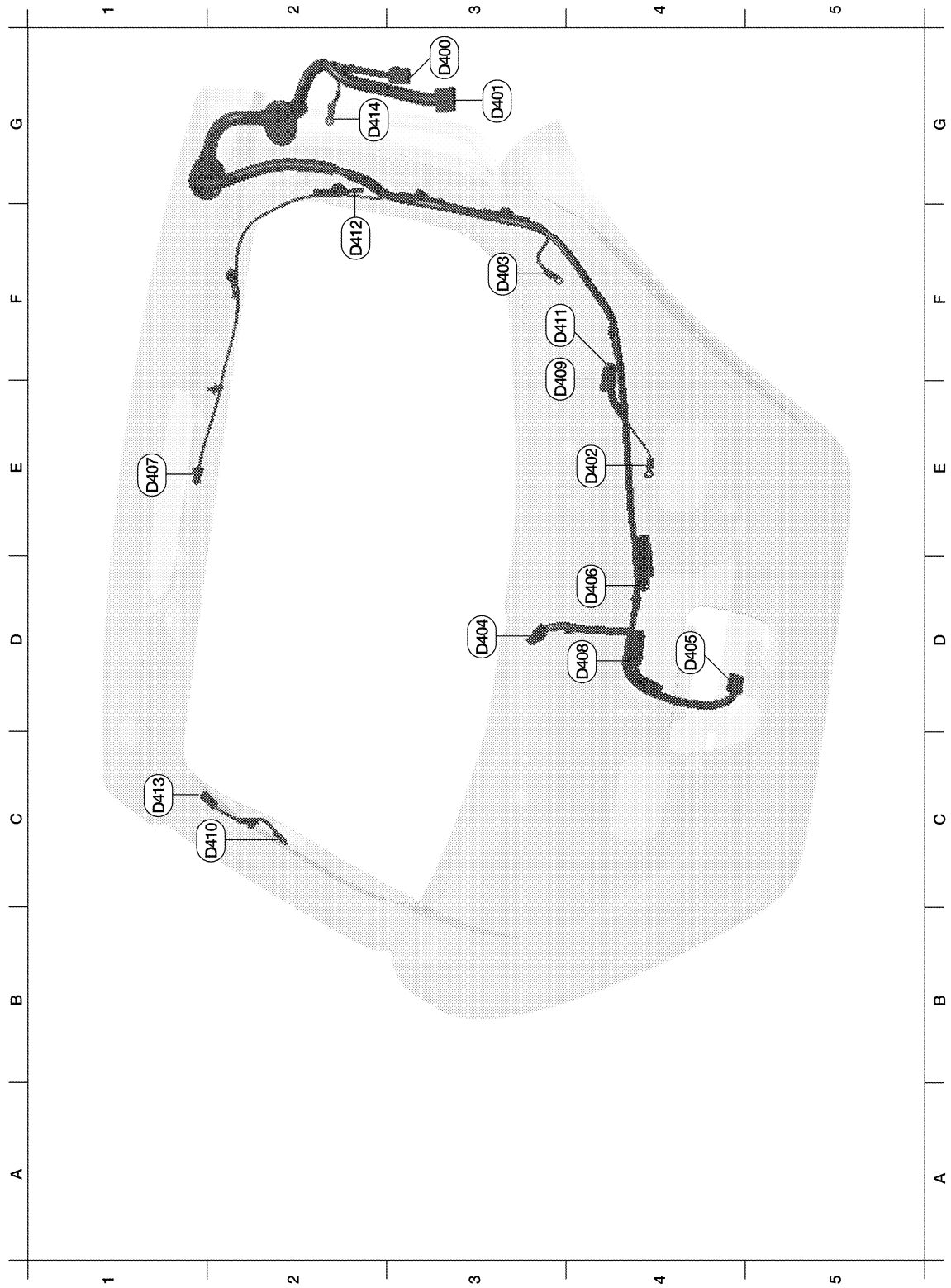

AAMIA0143GB

G3	D400	W/2	: To B133	D4	D408	BR/2	: Back door opener switch
G3	D401	W/12	: To B134	E4	D409	B/1	: Condenser-1
E4	D402	—	: Body ground	C2	D410	—	: Body ground
F3	D403	—	: Body ground	E3	D411	B/1	: Condenser-1
D3	D404	W/3	: Rear wiper motor	E1	D412	B/1	: Rear window defogger (+)



# HARNESS

## < SERVICE INFORMATION >

D4	D405	W/4	: Back door lock assembly	C2	D413	B/1	: Rear window defogger (-)
D4	D406	W/2	: Back door request switch	F3	D414	—	: Body ground
E2	D407	W/2	: High mounted stop lamp				

## Wiring Diagram Codes (Cell Codes)

INFOID:000000004306667

Use the chart below to find out what each wiring diagram code stands for. Refer to the wiring diagram code in the alphabetical index to find the location (page number) of each wiring diagram.

Code	Section	Wiring Diagram Name
ABS	BRC	Anti-lock Brake System
A/C,M	MTC	Manual Air Conditioner
APPS1	EC	Accelerator Pedal Position Sensor
A/F	EC	Air Fuel Ratio Sensor 1
A/FH	EC	Air Fuel Ratio Sensor 1 Heater
APPS2	EC	Accelerator Pedal Position Sensor
APPS3	EC	Accelerator Pedal Position Sensor
ASC/BS	EC	ASCD Brake Switch
ASC/SW	EC	ASCD Steering Switch
ASCBOF	EC	ASCD Brake Switch
ASCIND	EC	ASCD Indicator
AT/IND	DI	A/T Indicator Lamp
AUDIO	AV	Audio
BACK/L	LT	Back-up Lamp
BA/FTS	AT	A/T Fluid Temperature Sensor and TCM Power Supply
B/DOOR	BL	Back Door Opener
BRK/SW	EC	Brake Switch
CAN	AT	CAN Communication Line
CAN	CVT	CAN Communication Line
CAN	EC	CAN Communication Line
CAN	LAN	CAN System
CHARGE	SC	Charging System
CHIME	DI	Warning Chime
COOL/F	EC	Cooling Fan Control
COMBSW	LT	Combination Switch
CVTIND	DI	CVT Indicator Lamp
D/LOCK	BL	Power Door Lock
DEF	GW	Rear Window Defogger
DTRL	LT	Headlamp - With Daytime Light System
ECTS	EC	Engine Coolant Temperature Sensor
ENGSS	AT	Engine Speed Signal
EPS	STC	Electronic Controlled Power Steering
ETC1	EC	Electric Throttle Control Function
ETC2	EC	Throttle Control Motor Relay
ETC3	EC	Throttle Control Motor
F/FOG	LT	Front Fog Lamp
F/PUMP	EC	Fuel Pump
FTS	AT	A/T Fluid Temperature Sensor
FTS	CVT	CVT Fluid Temperature Sensor Circuit
FTTS	EC	Fuel Tank Temperature Sensor
FUEL	EC	Fuel Ignition System Function
HEATER	MTC	Heater System

# HARNESSES

## < SERVICE INFORMATION >

H/LAMP	LT	Headlamp
H/PHON	AV	Hands Free Telephone
HORN	WW	Horn
HO2S2	EC	Heated Oxygen Sensor 2
HO2S2H	EC	Heated Oxygen Sensor 2 Heater
IATS	EC	Intake Air Temperature Sensor
IGNSYS	EC	Ignition System
I/KEY	BL	Intelligent Key System
ILL	LT	Illumination
INJECT	EC	Injector
INT/L	LT	Room/Map, Vanity and Luggage Lamps
IVC	EC	Intake Valve Timing Control Solenoid Valve
KEYLES	BL	Remote Keyless Entry System
KS	EC	Knock Sensor
LPSV	AT	Line Pressure Solenoid Valve
LPSV	CVT	Line Pressure Solenoid Valve
L/USSV	CVT	Lock-up Select Solenoid Valve
MAFS	EC	Mass Air Flow Sensor
MAIN	AT	Main Power Supply and Ground Circuit
MAIN	EC	Main Power Supply and Ground Circuit
METER	DI	Speedometer, Tachometer, Temp. and Fuel Gauges
MIL/DL	EC	Malfunction Indicator Lamp
MIRROR	GW	Door Mirror
NATS	BL	Nissan Anti-Theft System
NONDTC	AT	Non-detectable Item
NONDTC	CVT	Non-detectable Item
ODSW	CVT	Overdrive Control Switch
OVRCSV	AT	Over Run Clutch Solenoid Valve
P/SCKT	WW	Power Socket
PGC/V	EC	EVAP Canister Purge Volume Control Solenoid Valve
PHASE	EC	Camshaft Position Sensor (PHASE)
PNP/SW	AT	Park/Neutral Position Switch
PNP/SW	CVT	Park/Neutral Position Switch
PNP/SW	EC	Park/Neutral Position Switch
POS	EC	Crankshaft Position Sensor (POS)
POWER	CVT	Transmission Control Module (Power Supply)
PRE/SE	EC	EVAP Control System Pressure Sensor
PRIPS	CVT	Primary Pressure Sensor
PRSCVT	CVT	Primary Speed Sensor CVT (Revolution Sensor)
PT/SEN	AT	Powertrain Revolution Sensor
RP/SEN	EC	Refrigerant Pressure Sensor
SECPS	CVT	Secondary Pressure Sensor
SECPSV	CVT	Secondary Speed Sensor CVT (Revolution Sensor)
SEN/PW	EC	Sensor Power Supply
SESCVT	CVT	Secondary Pressure Sensor Solenoid Valve
SHIFT	AT	A/T Shift Lock System
SHIFT	CVT	CVT Shift Lock System
SROOF	RF	Sunroof
SRS	SRS	Supplemental Restraint System
SSV/A	AT	Shift Solenoid Valve A
SSV/B	AT	Shift Solenoid Valve B
START	SC	Starting System

# HARNESSES

## < SERVICE INFORMATION >

STM	CVT	Step Motor	A
STOP/L	LT	Stop Lamp	
TCV	AT	Torque Converter Clutch Solenoid Valve	
TCV	CVT	Torque Converter Clutch Solenoid Valve	B
T/LID	BL	Trunk Lid Opener	
T/WARN	WT	Low Tire Pressure Warning System	
TAIL/L	LT	Parking, License and Tail Lamps	C
TPS1	EC	Throttle Position Sensor	
TPS2	EC	Throttle Position Sensor	
TPS3	EC	Throttle Position Sensor	D
TURN	LT	Turn Signal and Hazard Warning Lamps	
VEHSEC	BL	Vehicle Security (Theft Warning) System	
VENT/V	EC	EVAP Canister Vent Control Valve	E
VSSA/T	AT	Vehicle Speed Sensor A/T (Revolution Sensor)	
VSSMTR	AT	Vehicle Speed Sensor MTR	
WARN	DI	Warning Lamps	F
WINDOW	GW	Power Window	
WIP/R	WW	Rear Wiper and Washer	
WIPER	WW	Front Wiper and Washer	G

A  
B  
C  
D  
E  
F  
G  
H  
I  
J  
L  
M  
N  
O  
P

PG

# ELECTRICAL UNITS LOCATION

< SERVICE INFORMATION >

## ELECTRICAL UNITS LOCATION

### Electrical Units Location

INFOID:000000004306668

#### ENGINE COMPARTMENT

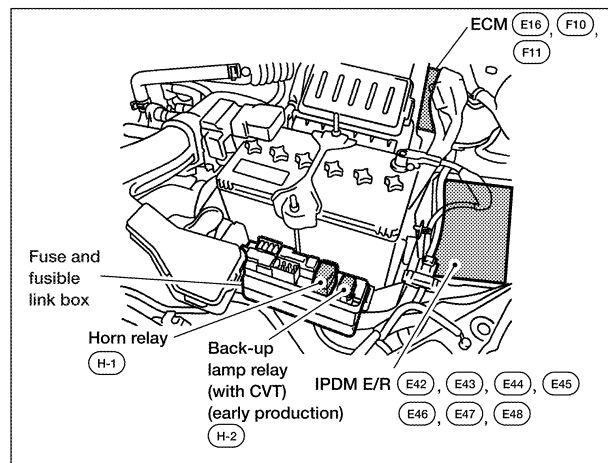
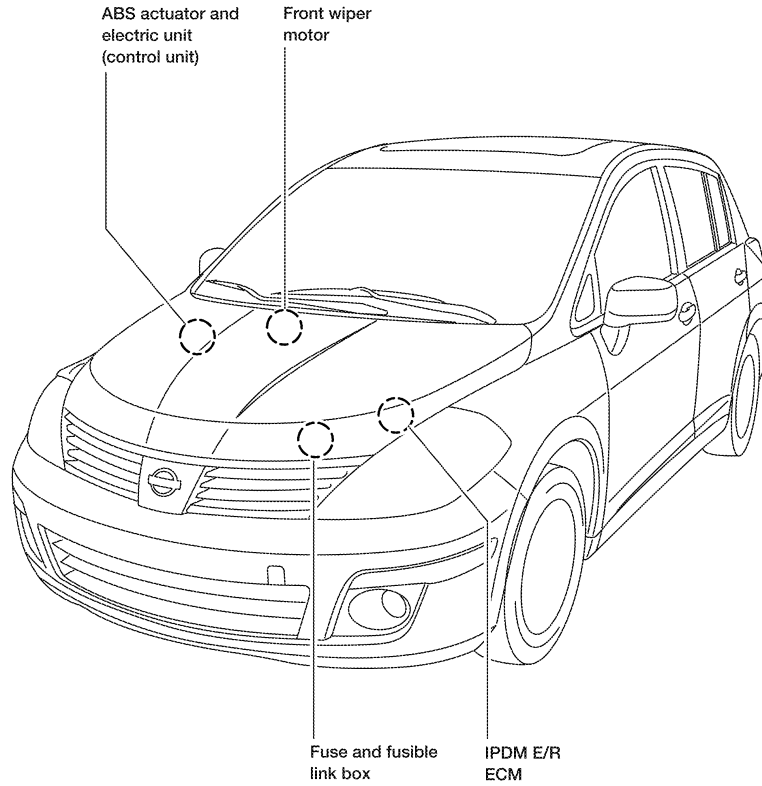

AAMIA0144GB

# ELECTRICAL UNITS LOCATION

< SERVICE INFORMATION >  
PASSENGER COMPARTMENT

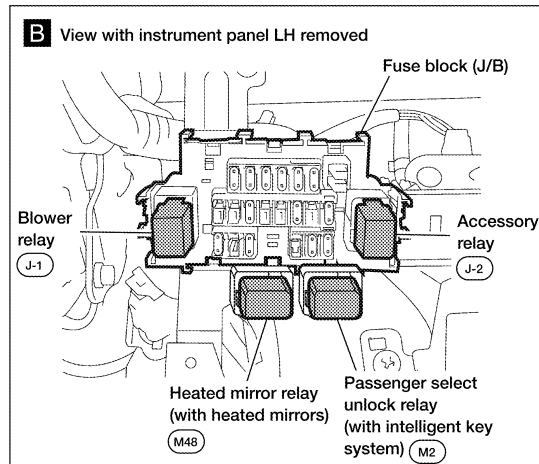
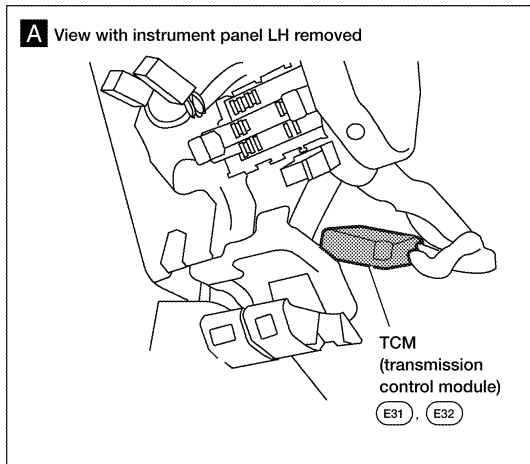
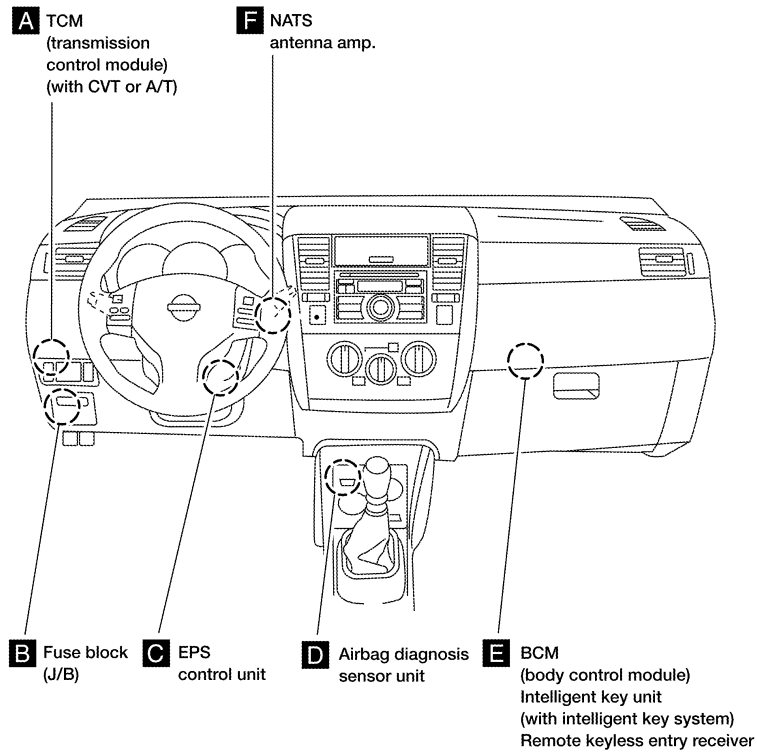

AAMIA0145GB

A  
B  
C  
D  
E  
F  
G  
H  
I  
J  
PG  
L  
M  
N  
O  
P

# ELECTRICAL UNITS LOCATION

< SERVICE INFORMATION >

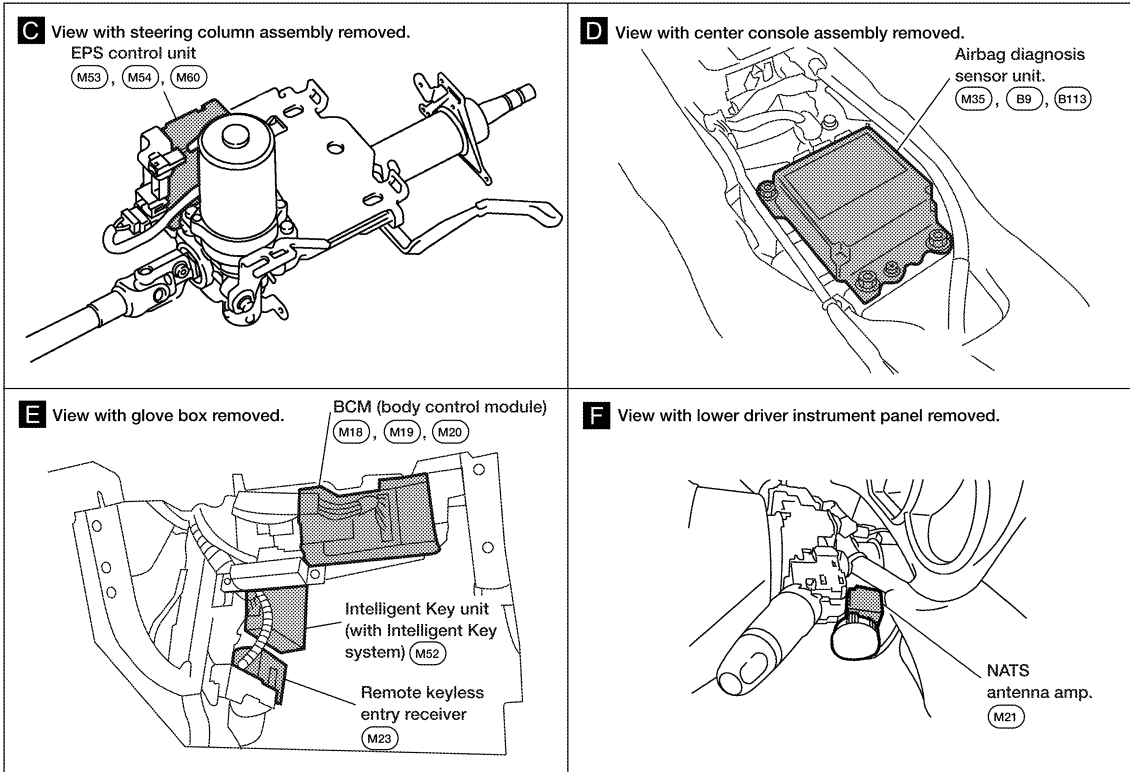

AAMIA0146GB

# ELECTRICAL UNITS LOCATION

< SERVICE INFORMATION >  
LUGGAGE COMPARTMENT

A  
B  
C  
D  
E  
F  
G  
H  
I  
J  
PG  
L  
M  
N  
O  
P

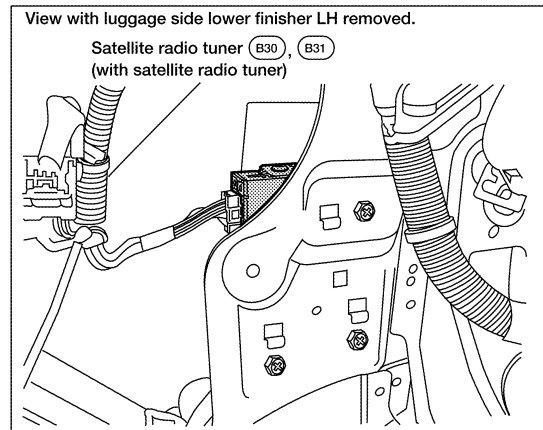
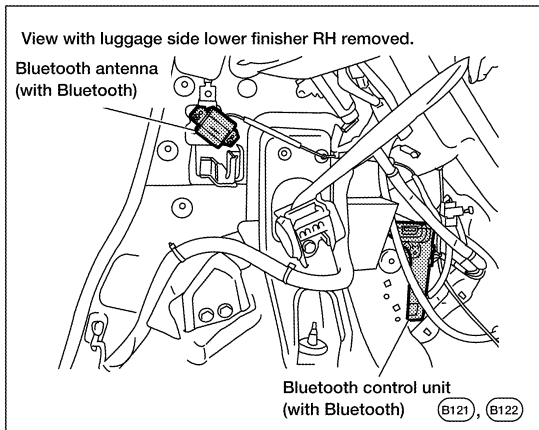
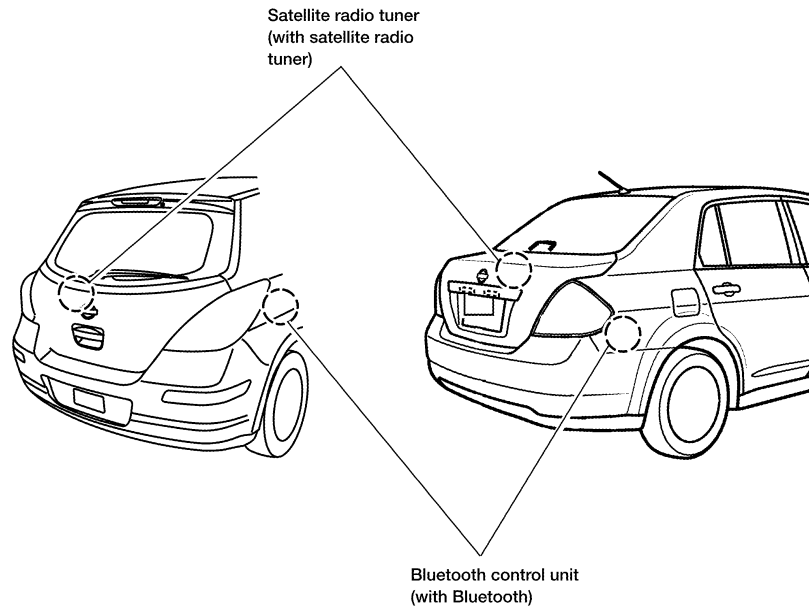

WKIA5998E

# HARNESS CONNECTOR

< SERVICE INFORMATION >

## HARNESS CONNECTOR

### Description

INFOID:000000004306669

#### HARNESS CONNECTOR (TAB-LOCKING TYPE)

- The tab-locking type connectors help prevent accidental looseness or disconnection.
- The tab-locking type connectors are disconnected by pushing or lifting the locking tab(s). Refer to the illustration below.

Refer to the next page for description of the slide-locking type connector.

**CAUTION:**

Do not pull the harness or wires when disconnecting the connector.

[Example]

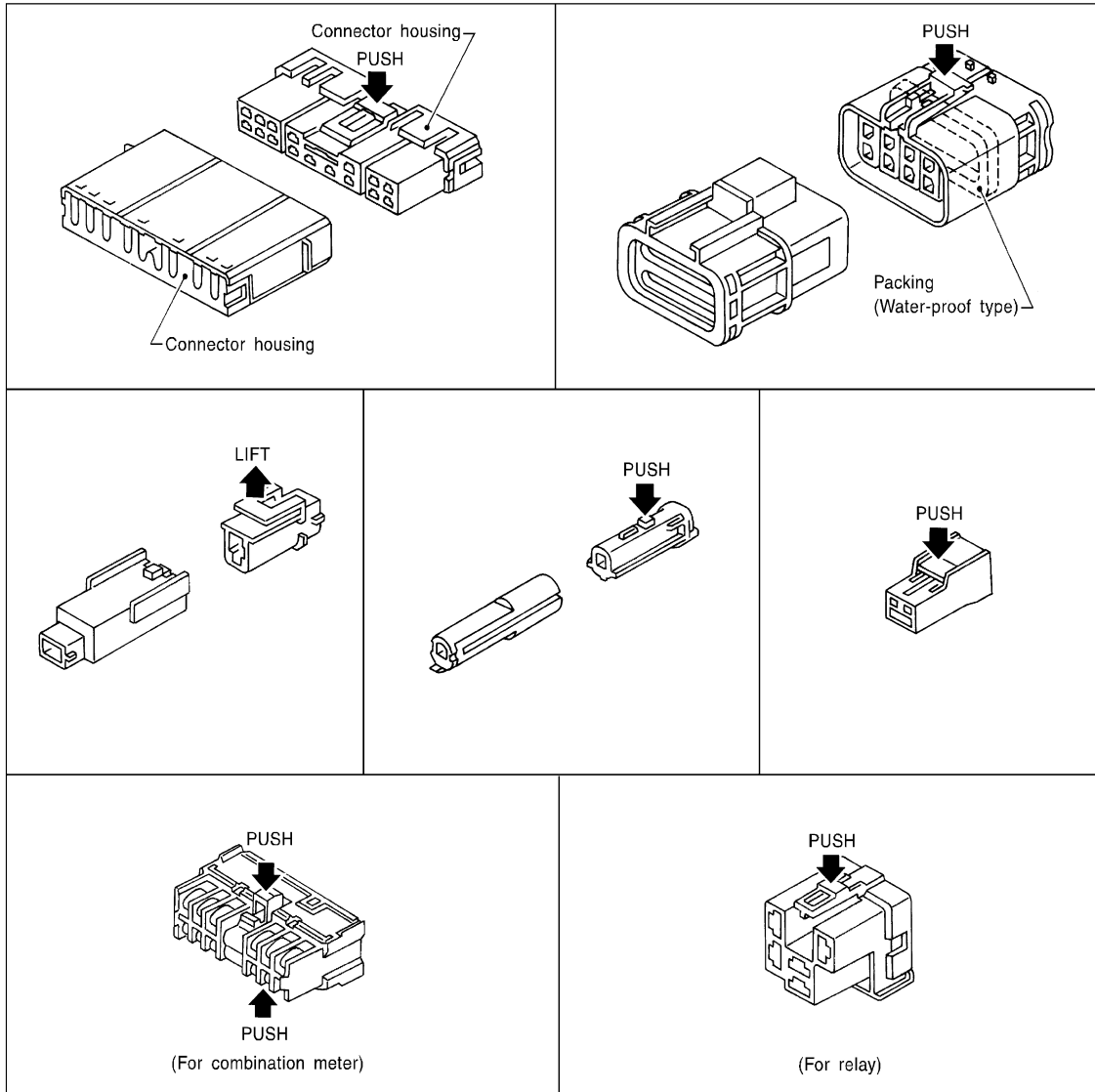

SEL769DA

#### HARNESS CONNECTOR (SLIDE-LOCKING TYPE)

- A new style slide-locking type connector is used on certain systems and components, especially those related to OBD.
- The slide-locking type connectors help prevent incomplete locking and accidental looseness or disconnection.
- The slide-locking type connectors are disconnected by pushing or pulling the slider. Refer to the figure below.



# HARNESS CONNECTOR

< SERVICE INFORMATION >

**CAUTION:**

- Do not pull the harness or wires when disconnecting the connector.
- Be careful not to damage the connector support bracket when disconnecting the connector.

[Example]

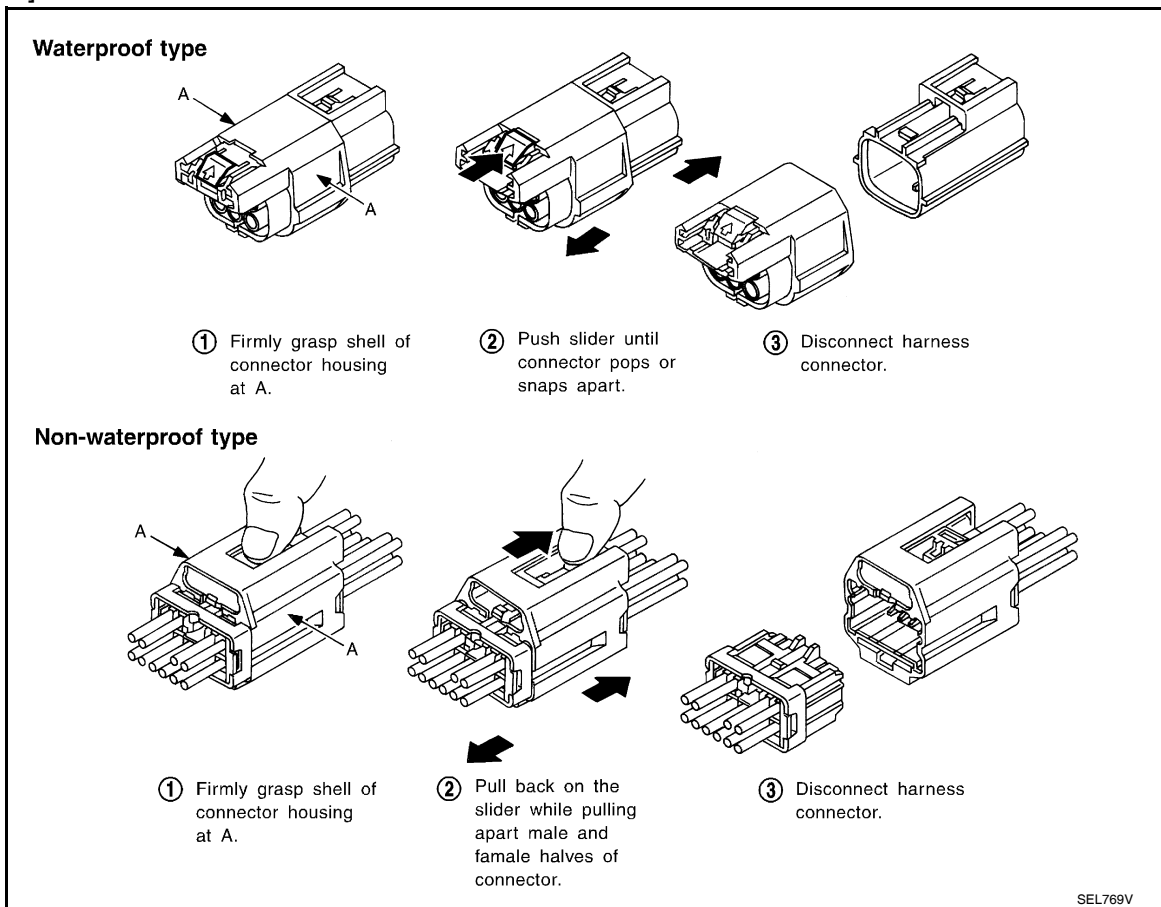

## HARNESS CONNECTOR (LEVER LOCKING TYPE)

- Lever locking type harness connectors are used on certain control units and control modules such as ECM, ABS actuator and electric unit (control unit), etc.
- Lever locking type harness connectors are also used on super multiple junction (SMJ) connectors.
- Always confirm the lever is fully locked in place by moving the lever as far as it will go to ensure full connection.

**CAUTION:**

A  
B  
C  
D  
E  
F  
G  
H  
I  
J  
PG  
L  
M  
N  
O  
P

# HARNES CONNECTOR

## < SERVICE INFORMATION >

Always confirm the lever is fully released (loosened) before attempting to disconnect or connect these connectors to avoid damage to the connector housing or terminals.

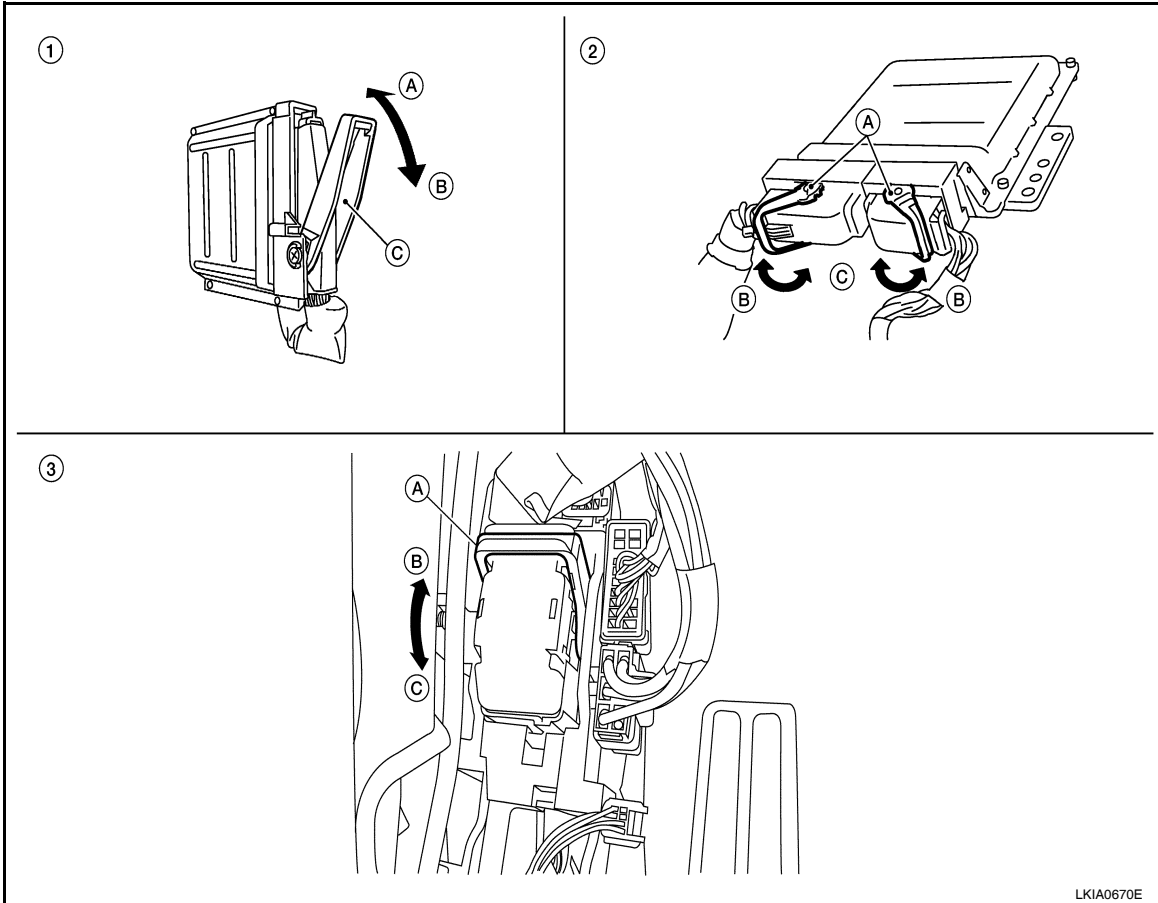

LKIA0670E

- |  |  |   |
|--|--|---|
| <p>1. Control unit with single lever</p> <p>A. Fasten</p> <p>B. Loosen</p> <p>C. Lever</p> | <p>2. Control unit with dual levers</p> <p>A. Levers</p> <p>B. Fasten</p> <p>C. Loosen</p> | <p>3. SMJ connector</p> <p>A. Lever</p> <p>B. Fasten</p> <p>C. Loosen</p> |
|--|--|---|

## HARNES CONNECTOR (DIRECT-CONNECT SRS COMPONENT TYPE)

- SRS direct-connect type harness connectors are used on certain SRS components such as air bag modules and seat belt pre-tensioners.
- Always pull up to release black locking tab prior to removing connector from SRS component.
- Always push down to lock black locking tab after installing connector to SRS component. When locked, the black locking tab is level with the connector housing.

### CAUTION:

- Do not pull the harness or wires when removing connectors from SRS components.

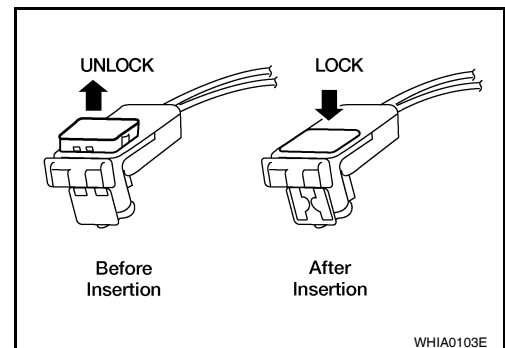

WHIA0103E

# ELECTRICAL UNITS

< SERVICE INFORMATION >

## ELECTRICAL UNITS

### Terminal Arrangement

INFOID:000000004306670

#### BCM (BODY CONTROL MODULE)

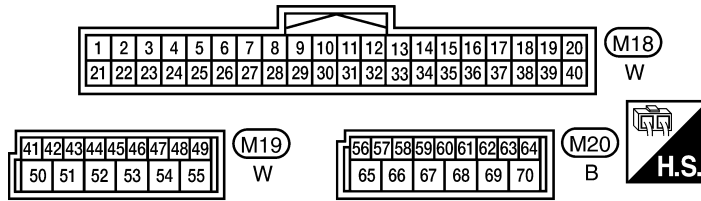

#### ABS ACTUATOR AND ELECTRIC UNIT (CONTROL UNIT)

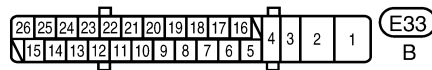

#### ECM

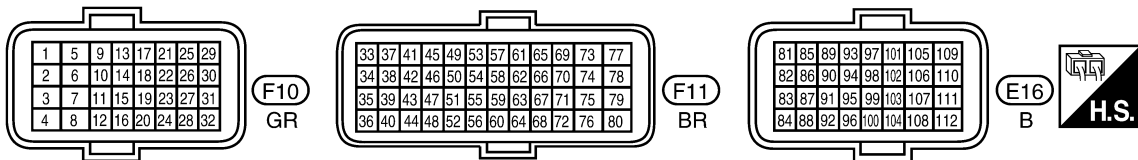

#### TCM (TRANSMISSION CONTROL MODULE)

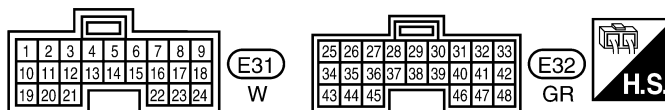

LKIA0810E

# STANDARDIZED RELAY

< SERVICE INFORMATION >

## STANDARDIZED RELAY

### Description

INFOID:000000004306671

### NORMAL OPEN, NORMAL CLOSED AND MIXED TYPE RELAYS

Relays can mainly be divided into three types: normal open, normal closed and mixed type relays.

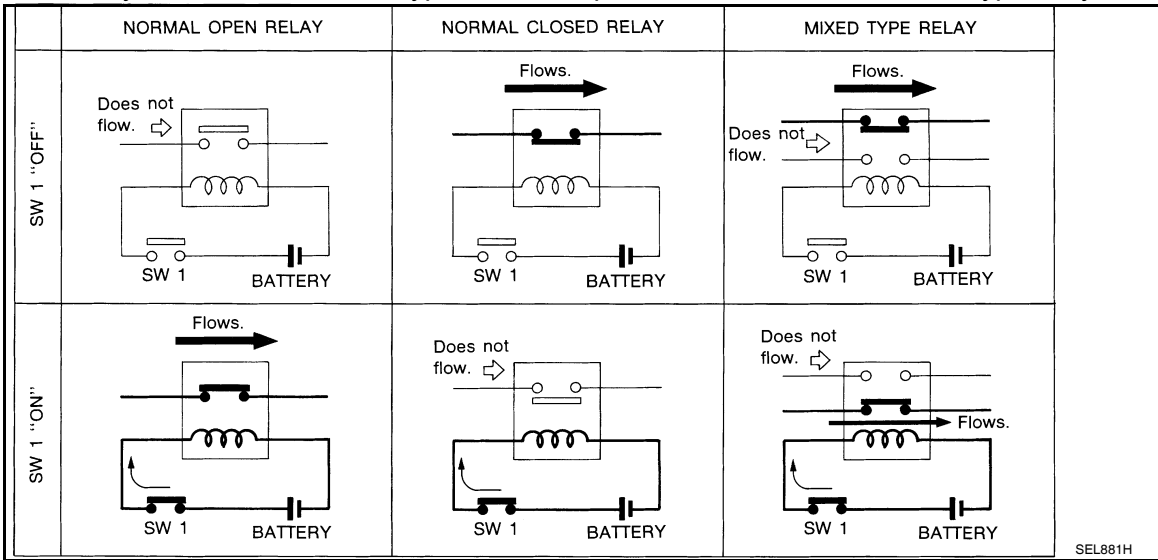

### TYPE OF STANDARDIZED RELAYS

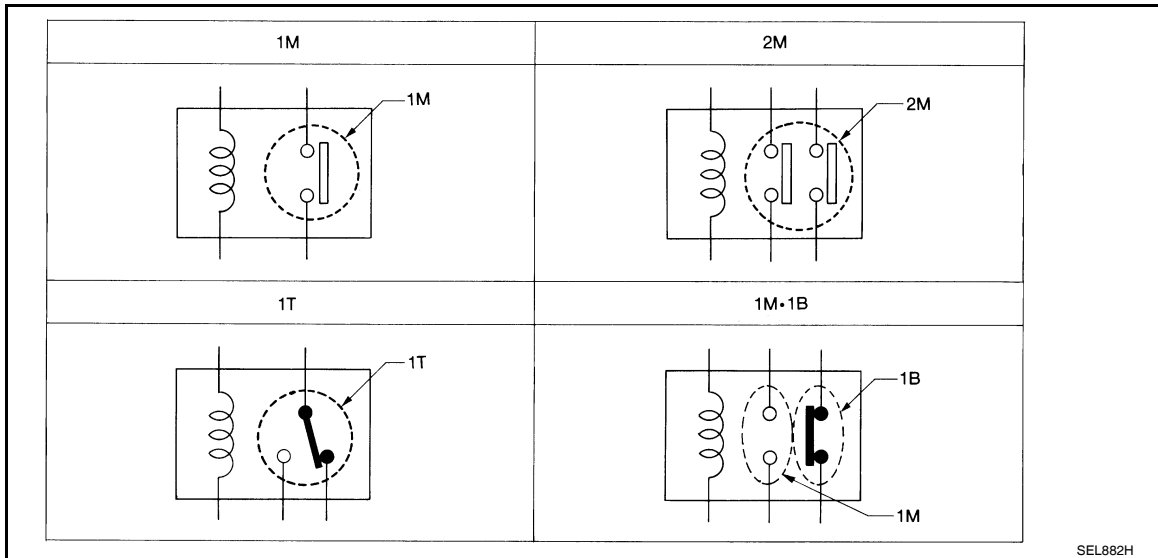

1M	1 Make	2M	2 Make
1T	1 Transfer	1M·1B	1 Make 1 Break

# STANDARDIZED RELAY

< SERVICE INFORMATION >

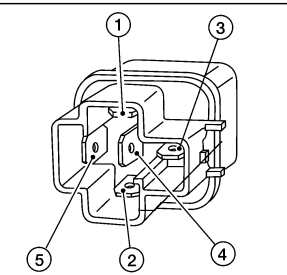
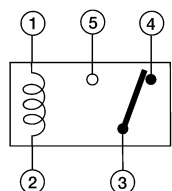
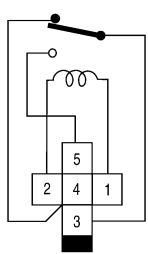
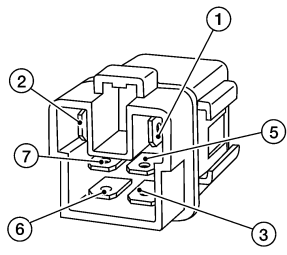
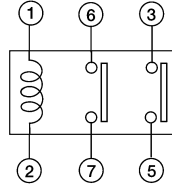
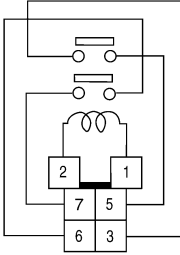
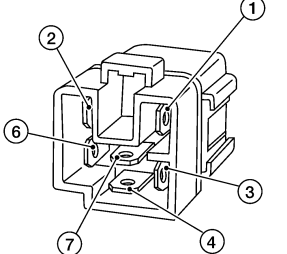
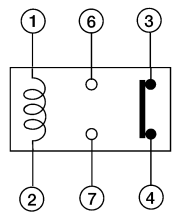
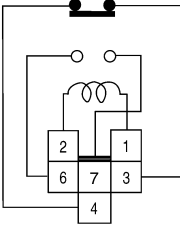
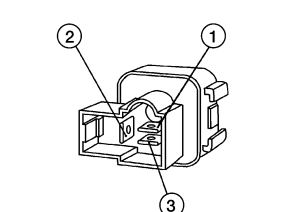
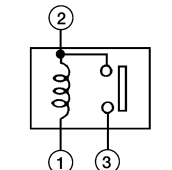
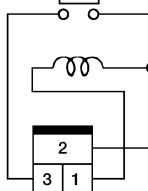
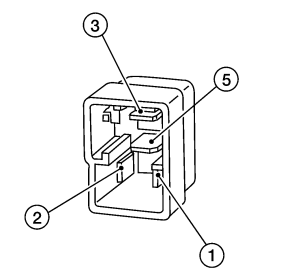
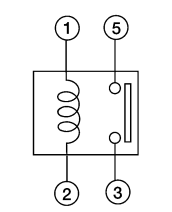
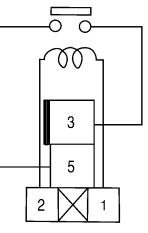
Type	Outer view	Circuit	Connector Symbol and connection	Case color
1T				BLACK
2M				BROWN
1M-1B				GRAY
1M				BLACK
				BLUE

The arrangement of terminal numbers on the actual relays may differ from those shown above.

WKIA0253E

A  
B  
C  
D  
E  
F  
G  
H  
I  
J  
PG  
L  
M  
N  
O  
P

# SUPER MULTIPLE JUNCTION (SMJ)

< SERVICE INFORMATION >

## SUPER MULTIPLE JUNCTION (SMJ)

### Terminal Arrangement

INFOID:000000004306672

EP : EARLY PRODUCTION

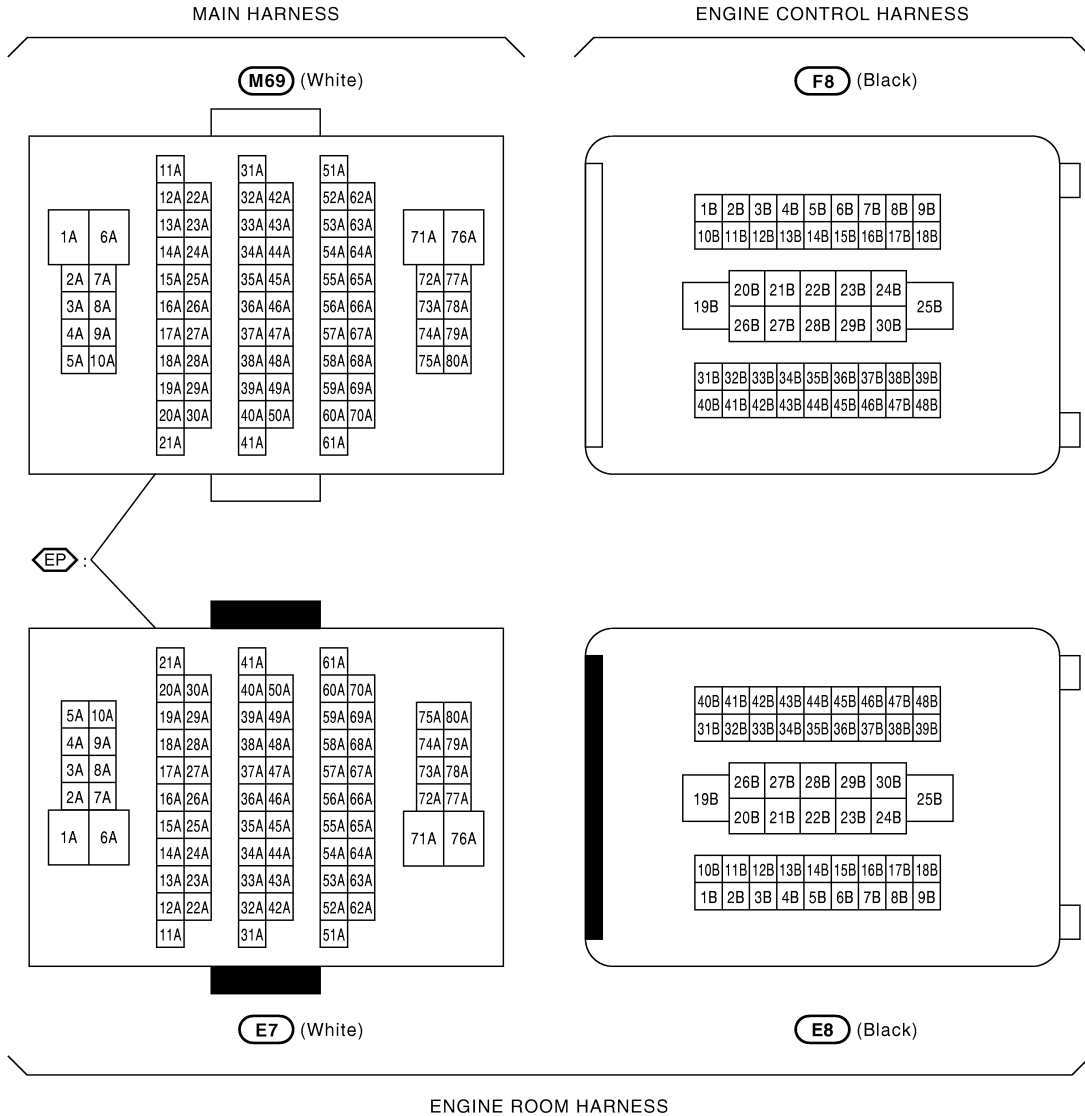

AAMIA0147GB

# SUPER MULTIPLE JUNCTION (SMJ)

< SERVICE INFORMATION >

 : LATE PRODUCTION

A  
B  
C  
D  
E  
F  
G  
H  
I  
J  
PG  
L  
M  
N  
O  
P

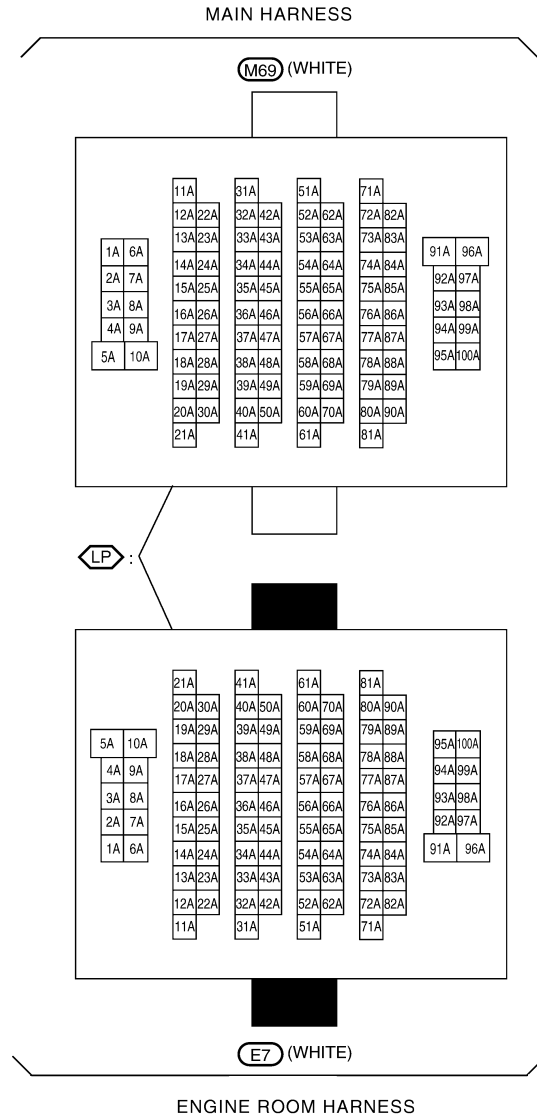

AAMIA0148GB

# FUSE BLOCK-JUNCTION BOX (J/B)

< SERVICE INFORMATION >

## FUSE BLOCK-JUNCTION BOX (J/B)

### Terminal Arrangement

INFOID:000000004306673

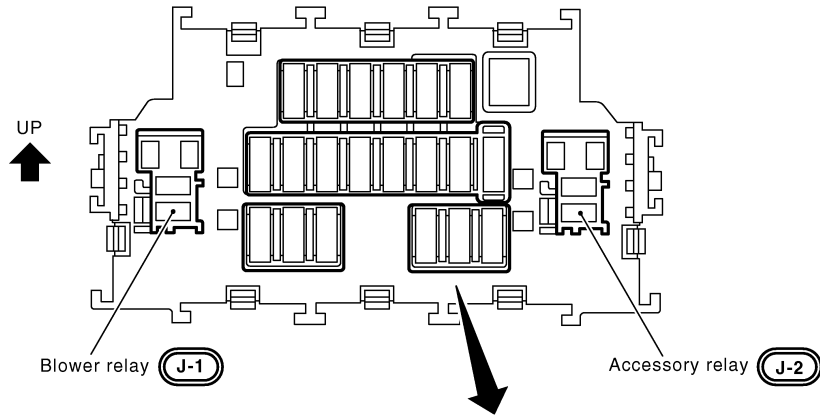

1 10 A	2 10 A	3 10 A	4 15 A	5 10 A	6 10 A								
7 10 A	8 10 A	9 X	10 X	11 X	12 X	13 10 A	14 10 A						
15 15 A	16 10 A	17 15 A				18 X	19 15 A	20 10 A					

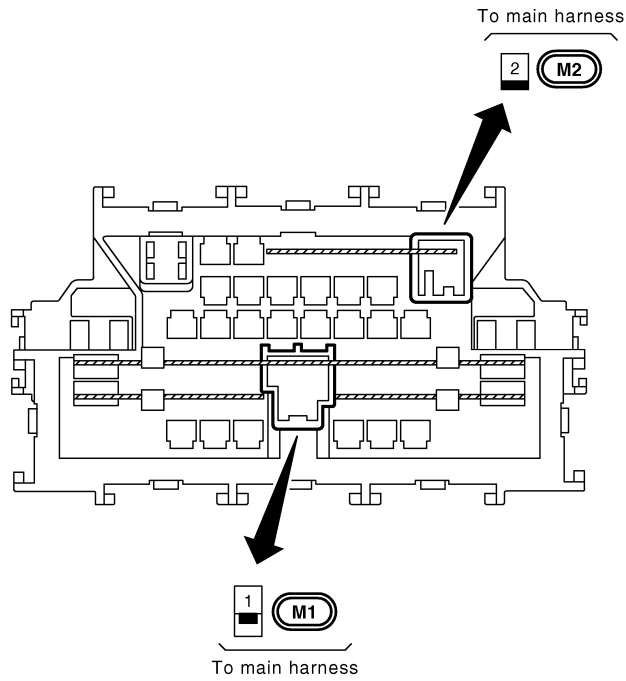

LKIA0812E



# FUSE AND FUSIBLE LINK BOX

< SERVICE INFORMATION >

## FUSE AND FUSIBLE LINK BOX

### Terminal Arrangement

INFOID:000000004306674

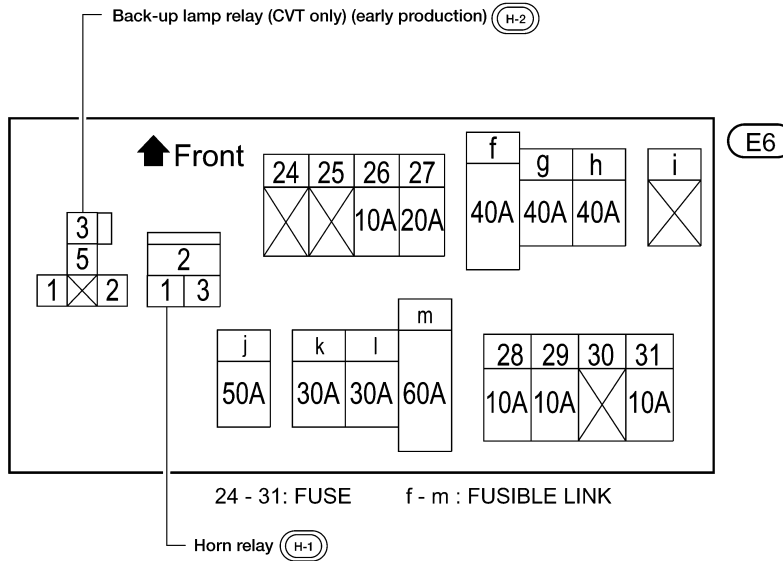

### FUSIBLE LINK BOX (BATTERY)

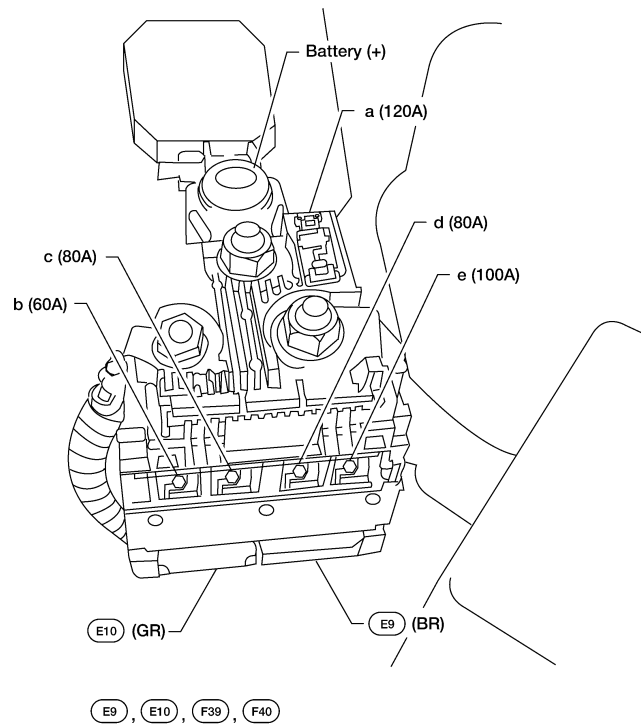

AAMIA0149GB