

SECTION **STC**

STEERING CONTROL SYSTEM

A
B
C
D
E

CONTENTS

EPS	TROUBLE DIAGNOSIS FOR SYSTEM	16
PRECAUTIONS	DTC C1601 BATTERY VOLT	16
Precautions for Supplemental Restraint System (SRS) "AIR BAG" and "SEAT BELT PRE-TENSIONER"	CONSULT-II REFERENCE VALUE IN DATA MONITOR MODE	16
Precautions Necessary for Steering Wheel Rotation After Battery Disconnect	EPS CONTROL UNIT TERMINALS AND REFERENCE VALUE	16
OPERATION PROCEDURE	DIAGNOSTIC PROCEDURE	17
Service Notice or Precautions for EPS System	DTC C1604 TORQUE SENSOR	19
EPS SYSTEM	CONSULT-II REFERENCE VALUE IN DATA MONITOR MODE	19
System Description	EPS CONTROL UNIT TERMINALS AND REFERENCE VALUE	19
EPS CONTROL UNIT	DIAGNOSTIC PROCEDURE	19
EPS MOTOR	DTC C1606 EPS MOTOR	21
TORQUE SENSOR	CONSULT-II REFERENCE VALUE IN DATA MONITOR MODE	21
REDUCTION GEAR	EPS CONTROL UNIT TERMINALS AND REFERENCE VALUE	21
EPS WARNING LAMP	DIAGNOSTIC PROCEDURE	21
System Diagram	DTC C1607 EEPROM	22
COMPONENTS FUNCTION DESCRIPTION	DIAGNOSTIC PROCEDURE	22
CAN Communication	DTC C1608 CONTROL UNIT	22
SYSTEM DESCRIPTION	DIAGNOSTIC PROCEDURE	22
TROUBLE DIAGNOSIS	DTC C1609 CAN VHCL SPEED	23
Fail-Safe Function	CONSULT-II REFERENCE VALUE IN DATA MONITOR MODE	23
How to Perform Trouble Diagnosis	DIAGNOSTIC PROCEDURE	23
BASIC CONCEPT	DTC C1610 CAN ENG RPM	24
PRECAUTIONS FOR TROUBLE DIAGNOSIS	CONSULT-II REFERENCE VALUE IN DATA MONITOR MODE	24
INTERVIEW	DIAGNOSTIC PROCEDURE	24
Component Parts Location	DTC U1000 CAN COMM CIRCUIT	24
Wiring Diagram — EPS —	DIAGNOSTIC PROCEDURE	24
EPS Control Unit Input/Output Signal Reference Values	Component Inspection	25
SPECIFICATIONS WITH CONSULT-II	EPS MOTOR	25
SPECIFICATIONS BETWEEN EPS CONTROL UNIT TERMINALS	TROUBLE DIAGNOSIS FOR SYMPTOMS	26
CONSULT-II Function (EPS)	EPS Warning Lamp Does Not Turn ON	26
FUNCTION	SYMPTOM:	26
CONSULT-II SETTING PROCEDURE	DIAGNOSTIC PROCEDURE	26
SELF-DIAG RESULTS MODE	EPS Warning Lamp Does Not Turn OFF	27
DATA MONITOR		
EPS CONTROL UNIT PART NUMBER		
Symptom Chart		

F
STC

H
I
J
K
L
M

SYMPTOM:	27	SYMPTOM:	31
DIAGNOSTIC PROCEDURE	27	DIAGNOSTIC PROCEDURE	31
Steering Wheel Turning Force is Heavy or Light ...	29	Unbalance Steering Wheel Turning Force (Torque	
SYMPTOM:	29	Variation)	32
DIAGNOSTIC PROCEDURE	29	SYMPTOM:	32
Unbalance Steering Wheel Turning Force and		DIAGNOSTIC PROCEDURE	32
Return Between Right and Left	31		

PRECAUTIONS

Precautions for Supplemental Restraint System (SRS) “AIR BAG” and “SEAT BELT PRE-TENSIONER”

UGS000A8

The Supplemental Restraint System such as “AIR BAG” and “SEAT BELT PRE-TENSIONER”, used along with a front seat belt, helps to reduce the risk or severity of injury to the driver and front passenger for certain types of collision. This system includes seat belt switch inputs and dual stage front air bag modules. The SRS system uses the seat belt switches to determine the front air bag deployment, and may only deploy one front air bag, depending on the severity of a collision and whether the front occupants are belted or unbelted. Information necessary to service the system safely is included in the SRS and SB section of this Service Manual.

WARNING:

- To avoid rendering the SRS inoperative, which could increase the risk of personal injury or death in the event of a collision which would result in air bag inflation, all maintenance must be performed by an authorized NISSAN/INFINITI dealer.
- Improper maintenance, including incorrect removal and installation of the SRS, can lead to personal injury caused by unintentional activation of the system. For removal of Spiral Cable and Air Bag Module, see the SRS section.
- Do not use electrical test equipment on any circuit related to the SRS unless instructed to in this Service Manual. SRS wiring harnesses can be identified by yellow and/or orange harnesses or harness connectors.

Precautions Necessary for Steering Wheel Rotation After Battery Disconnect

UGS000A9

NOTE:

- This Procedure is applied only to models with Intelligent Key system and NVIS/IVIS (NISSAN/INFINITI VEHICLE IMMOBILIZER SYSTEM - NATS).
- Remove and install all control units after disconnecting both battery cables with the ignition knob in the “LOCK” position.
- Always use CONSULT-II to perform self-diagnosis as a part of each function inspection after finishing work. If DTC is detected, perform trouble diagnosis according to self-diagnostic results.

For models equipped with the Intelligent Key system and NVIS/IVIS, an electrically controlled steering lock mechanism is adopted on the key cylinder.

For this reason, if the battery is disconnected or if the battery is discharged, the steering wheel will lock and steering wheel rotation will become impossible.

If steering wheel rotation is required when battery power is interrupted, follow the procedure below before starting the repair operation.

OPERATION PROCEDURE

1. Connect both battery cables.

NOTE:

Supply power using jumper cables if battery is discharged.

2. Use the Intelligent Key or mechanical key to turn the ignition switch to the “ACC” position. At this time, the steering lock will be released.
3. Disconnect both battery cables. The steering lock will remain released and the steering wheel can be rotated.
4. Perform the necessary repair operation.
5. When the repair work is completed, return the ignition switch to the “LOCK” position before connecting the battery cables. (At this time, the steering lock mechanism will engage.)
6. Perform a self-diagnosis check of all control units using CONSULT-II.

A
B
C
D
E
F
H
I
J
K
L
M

STC

Service Notice or Precautions for EPS System

CAUTION:

Check or confirm the following item when performing the trouble diagnosis.

- Check any possible causes by interviewing the symptom and it's condition from the customer if any malfunction, such as EPS warning lamp turns ON, occurs.
- Check if air pressure and size of tires are proper, the specified part is used for the steering wheel, and control unit is genuine part.
- Check if the connection of steering column assembly and steering gear assembly is proper (there is not looseness of mounting bolts, damage of rods, boots or sealants, and leakage of grease, etc).
- Check if the wheel alignment is adjusted properly.
- Check if there is any damage or modification to suspension or body resulting in increased weight or altered ground clearance.
- Check if installation conditions of each link and suspension are proper.
- Check if the battery voltage is proper
- Check connection conditions of each connector are proper.
- Before connecting or disconnecting the EPS control unit harness connector, turn ignition switch "OFF" and disconnect battery ground cable. Because battery voltage is applied to EPS control unit even if ignition switch is turned "OFF".

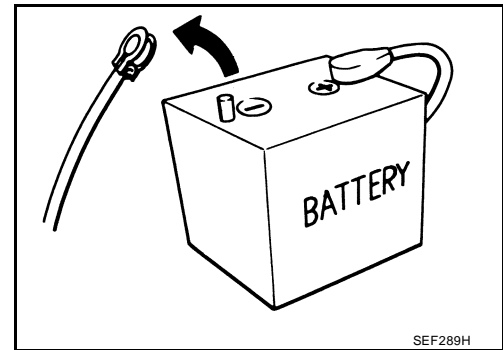

SEF289H

- When connecting or disconnecting pin connectors into or from EPS control unit, take care not to damage pin terminals (bend or break).
When connecting pin connectors, make sure that there are no bends or breaks on EPS control unit pin terminal.

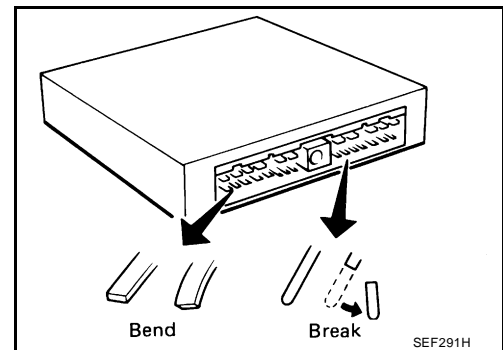

SEF291H

- Before replacing EPS control unit, perform EPS control unit input/output signal inspection and make sure whether EPS control unit functions properly or not. Refer to [STC-11, "EPS Control Unit Input/Output Signal Reference Values"](#).

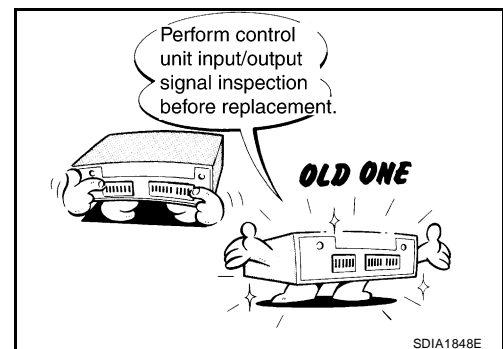

SDIA1848E

EPS SYSTEM

System Description EPS CONTROL UNIT

- EPS control unit performs an arithmetical operation on data, such as steering wheel turning force (sensor signal) from the torque sensor, vehicle speed signal, etc. Then it generates an optimum assist torque to the EPS motor according to the driving condition.
- EPS control unit decreases the output to EPS motor while extremely using the power steering function (e.g., full steering) for protecting EPS motor and EPS control unit (Protect overload status). While activating protect overload status, the assist torque gradually decreases, and the steering wheel turning force becomes heavy. The normal assist torque reactivates by not steering.
- In case of an error in the electrical system, the fail-safe function stops output signals to the EPS motor. Then the previous state is changed to the manual steering state.
- Self-diagnosis can be done with CONSULT-II.

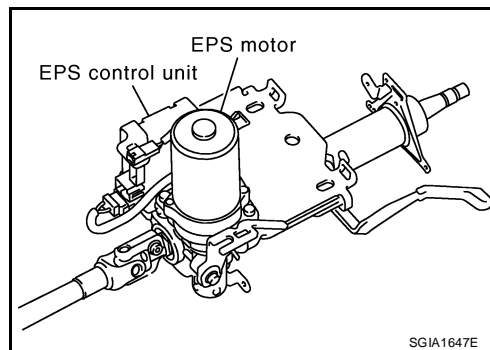

EPS MOTOR

EPS motor provides the assist torque by control signal from EPS control unit.

TORQUE SENSOR

Torque sensor detects the steering torque, and transmit the signal to EPS control unit.

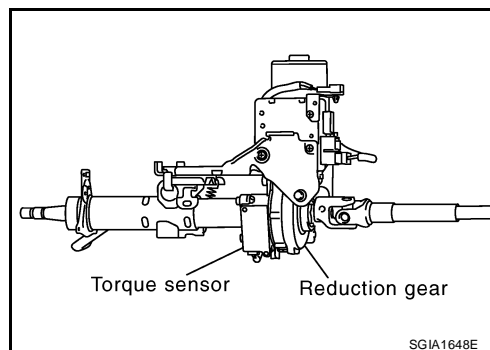

REDUCTION GEAR

Reduction gear increases the assist torque provided from EPS motor with worm gears, and outputs to the column shaft.

EPS WARNING LAMP

Turns ON when there is a malfunction in EPS system. It indicates that fail-safe mode is engaged and enters a manual steering state (Control turning force steering wheel becomes heavy). Also turns ON when ignition switch is turned ON, for purpose of lamp check. Turns OFF after the engine starts if system is normal.

EPS Warning Lamp Indication

Condition	EPS warning lamp
Lamp check	Turns ON when ignition switch is turned ON. Turns OFF after engine start.
EPS system malfunction	ON
Other than above (system normal)	OFF

System Diagram

UGS000A6

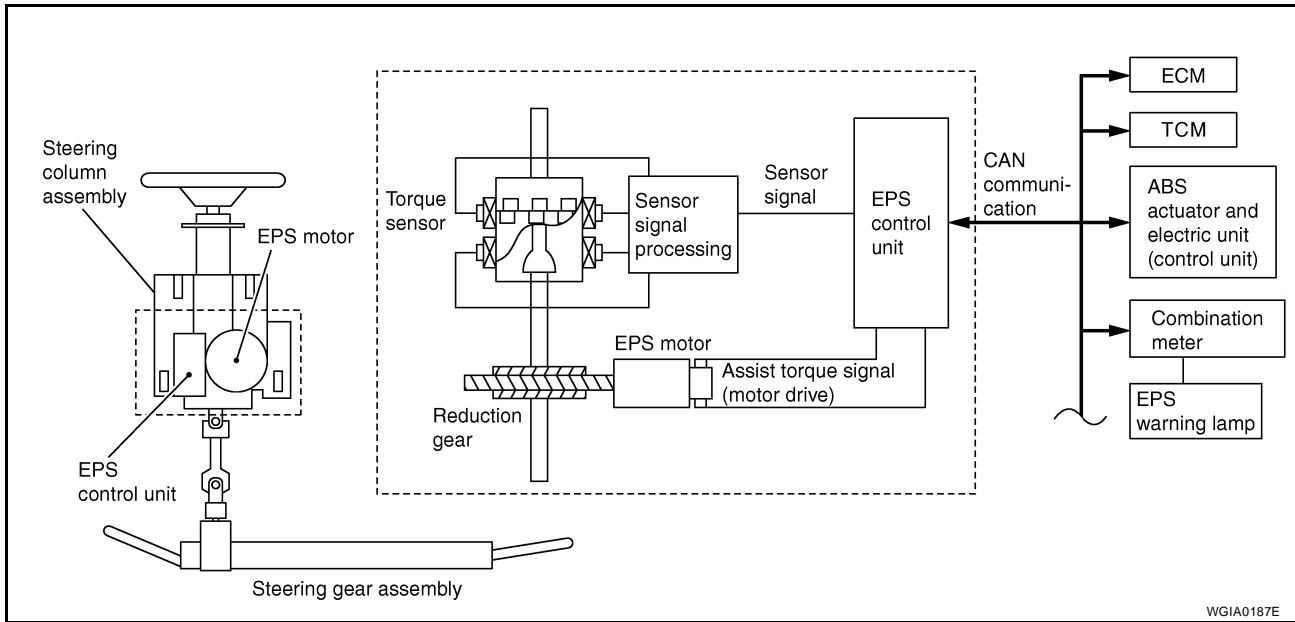

COMPONENTS FUNCTION DESCRIPTION

Component parts	Function
EPS control unit (Electric power steering control unit)	<ul style="list-style-type: none"> ● Outputs optimum assist torque signal to EPS motor. ● Reduces output signals to EPS motor and protects EPS motor and EPS control unit when using power steering continuously and excessively. ● As a fail-safe function, turned off output signal to EPS motor and then enters a manual steering state, if malfunction is detected in EPS system.
EPS motor	Products assist torque by control signal from EPS control unit.
Torque sensor	Detects steering wheel turning force and outputs sensor signal to EPS control unit.
Reduction gear	Increases motor-produced assist torque by worm gear and transmits it to column shaft.
EPS warning lamp	Illuminates if malfunction is detected in electrical system of EPS system.
ECM	Transmits the following signals via CAN communication to EPS control unit. <ul style="list-style-type: none"> ● Engine status signal
ABS actuator and electric unit (control unit) (With ABS)	Transmits the following signals via CAN communication to EPS control unit. <ul style="list-style-type: none"> ● Vehicle speed signal
Combination meter	Transmits the following signals via CAN communication to EPS control unit. <ul style="list-style-type: none"> ● Vehicle speed signal
TCM (Without ABS)	Transmits the following signals via CAN communication to EPS control unit. <ul style="list-style-type: none"> ● Vehicle speed signal

CAN Communication SYSTEM DESCRIPTION

UGS000A7

CAN (Controller Area Network) is a serial communication line for real time application. It is an on-vehicle multiplex communication line with high data communication speed and excellent error detection ability. Many electronic control units are equipped onto a vehicle, and each control unit shares information and links with other control units during operation (not independent). In CAN communication, control units are connected with 2 communication lines (CAN-H line, CAN-L line) allowing a high rate of information transmission with less wiring. Each control unit transmits/receives data but selectively reads required data only. For details, refer to [LAN-47, "CAN System Specification Chart"](#).

TROUBLE DIAGNOSIS

Fail-Safe Function

UGS0008G

- If any malfunction occurs in the system, and control unit detects the malfunction, EPS warning lamp on combination meter turns ON to indicate system malfunction.
- When EPS warning lamp is ON, enters a manual steering state. (Control turning force steering wheel becomes heavy.)

How to Perform Trouble Diagnosis

UGS00090

BASIC CONCEPT

- To perform trouble diagnosis, it is the must to have understanding about vehicle systems (control and mechanism) thoroughly.
- It is also important to clarify customer complaints before starting the inspection.
First of all, reproduce the symptoms, and understand them fully. Ask customer about his/her complaints carefully. In some cases, it will be necessary to check symptoms by driving vehicle with customer.

CAUTION:

Customers are not professionals. It is dangerous to make an easy guess like "maybe the customer means that..." or "maybe the customer mentions this symptom".

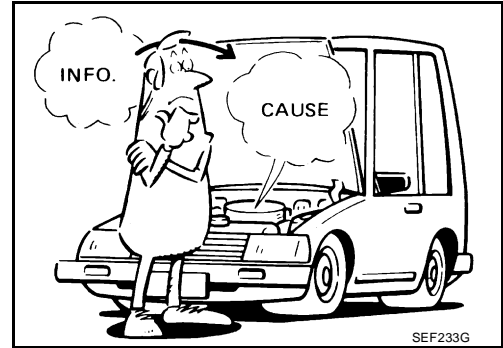

- It is essential to check symptoms right from the beginning in order to repair malfunctions completely. For intermittent malfunctions, reproduce symptoms based on interview with customer and past examples. Do not perform inspection on ad hoc basis. Most intermittent malfunctions are caused by poor contacts. In this case, it will be effective to shake suspected harness or connector by hand. When repairing without any symptom diagnosis, you cannot judge if malfunctions has actually been eliminated.

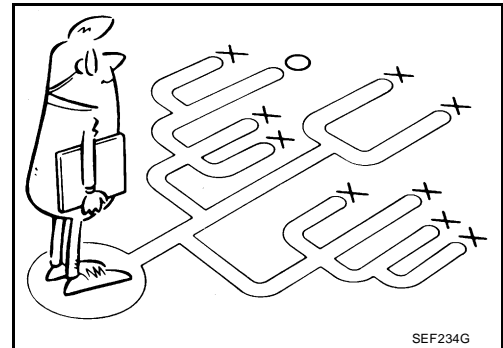

PRECAUTIONS FOR TROUBLE DIAGNOSIS

- Be sure to check the procedures of the trouble diagnosis in advance. Refer to [STC-7, "How to Perform Trouble Diagnosis"](#) .
- Always erase memory after completing trouble diagnosis. Refer to [STC-13, "How to Erase Self-Diagnostic Results"](#) .
- Checking continuity and voltage between units, be sure to check connector terminals for disconnection, looseness, bend, or collapse. Repair or replace applicable part if any non-standard condition is detected.
- Be careful not to forcibly extend any connector terminal if a circuit tester is used for the check.
- Always confirm the general precautions. Refer to [GI-4, "General Precautions"](#) .

INTERVIEW

- Complaints vary depending on the person. It is important to clarify the customer's actual remarks.
- Ask the customer about what symptoms occur under what conditions. Use the information to reproduce the symptom of confirm by vehicle.

KEY POINTS

WHAT Vehicle & engine model

WHEN Date, Frequencies

WHERE..... Road conditions

HOW Operating conditions,
Weather conditions,
Symptoms

SEF907L

Component Parts Location

UGS0007U

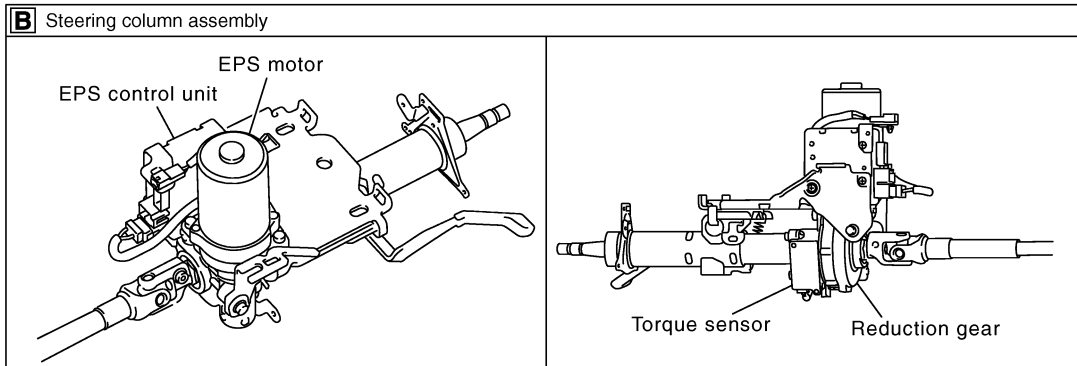
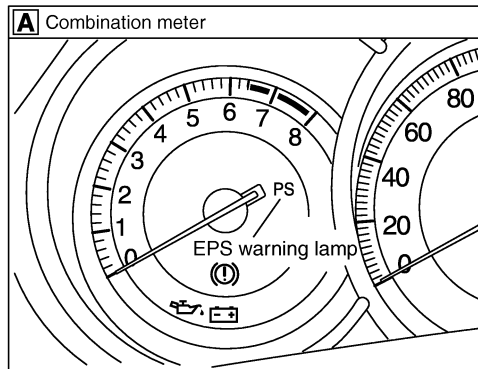
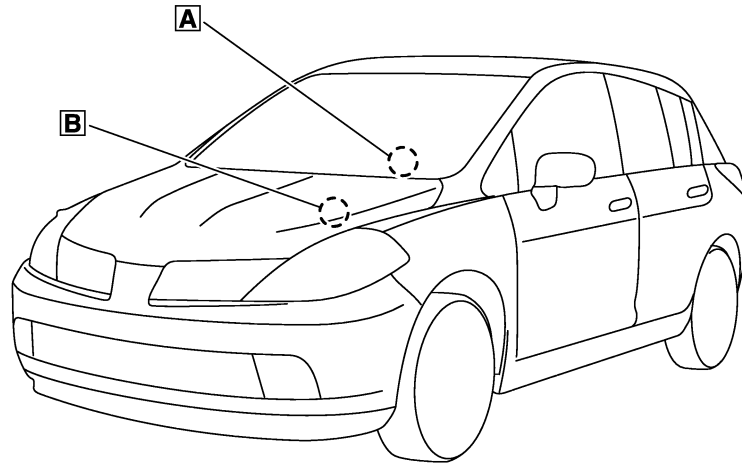

SGIA1623E

TROUBLE DIAGNOSIS

[EPS]

Wiring Diagram — EPS —

UGS0007W

STC-EPS-01

— : DATA LINE

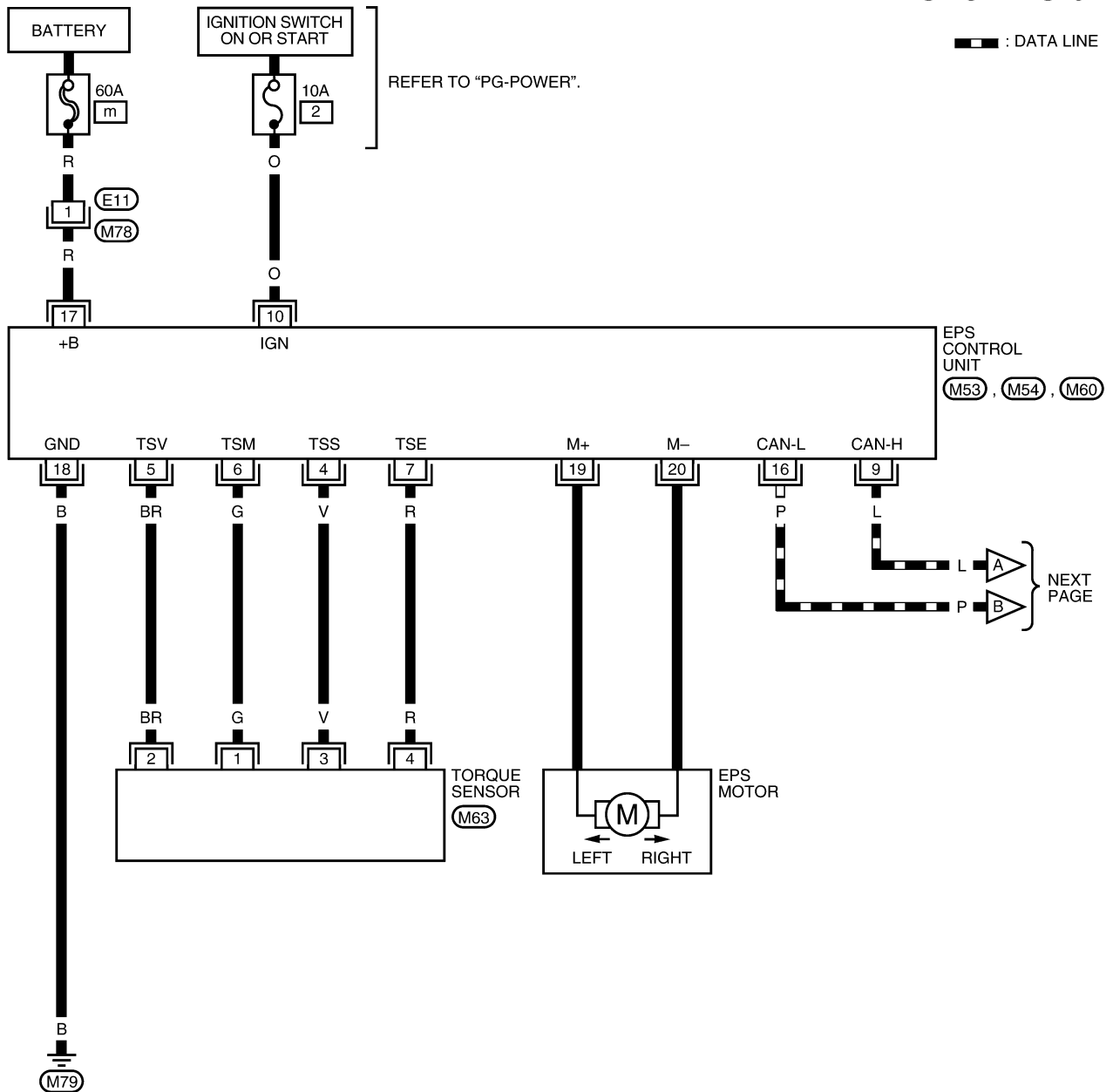

A
B
C
D
E
F
STC
H
I
J
K
L
M

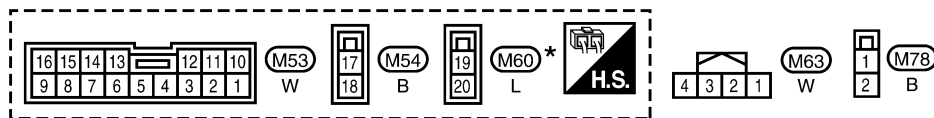

* : THIS CONNECTOR IS NOT SHOWN IN "HARNESS LAYOUT" OF PG SECTION.

BGWA0001E

TROUBLE DIAGNOSIS

[EPS]

STC-EPS-02

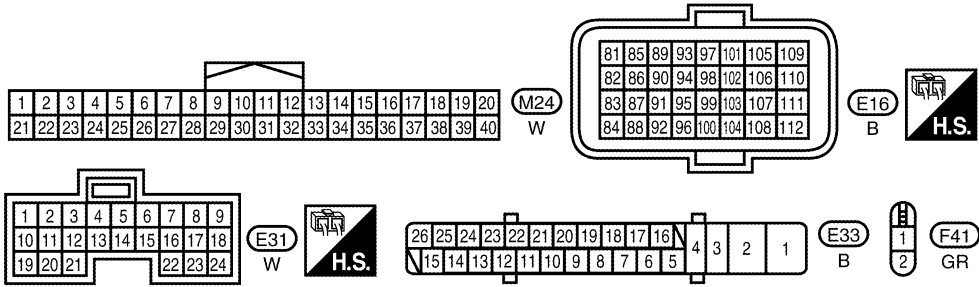
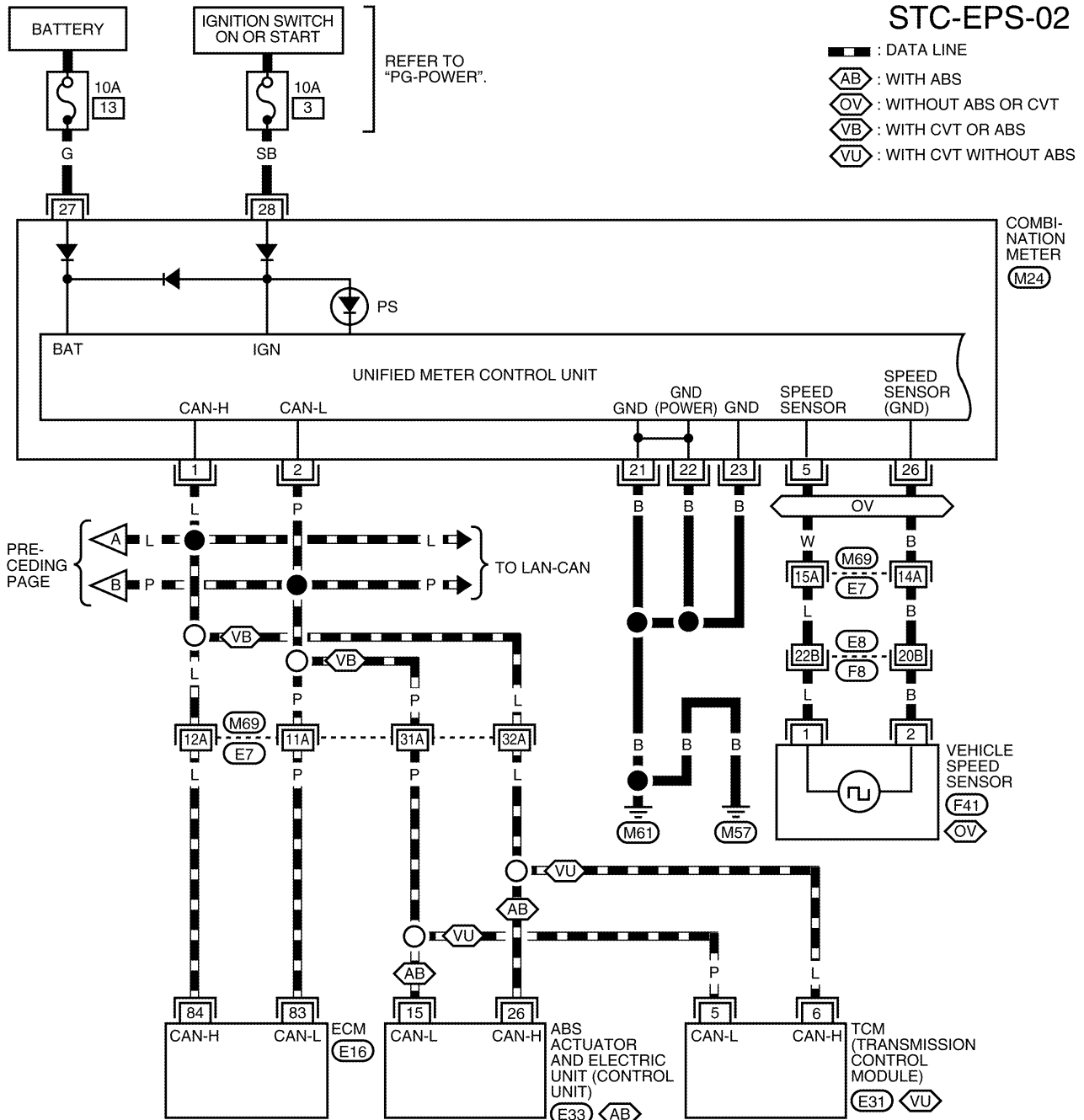

REFER TO THE FOLLOWING.
 (M69), (F8) - SUPER MULTIPLE JUNCTION (SMJ)

BGWA0002E

TROUBLE DIAGNOSIS

[EPS]

UGS0007X

EPS Control Unit Input/Output Signal Reference Values SPECIFICATIONS WITH CONSULT-II

CAUTION:

The output signal indicates the EPS control unit calculation date. The normal values will be displayed even in the event that the output circuit (harness) is open.

Monitor item (Unit)	Content	Condition		Display value
MOTOR VOL (V)	Power supply voltage for EPS control unit	Ignition switch: ON		Battery voltage
TORQUE SENSOR (Nm)	Steering wheel turning force	Engine running	Steering wheel: Not steering (There is no steering force)	0.00 Nm
			Steering wheel: Steering	0 – 8.19 Nm ^{*1} (The value is changed according to steering left or right)
MOTOR SIG (A)	Command current to EPS motor	Engine running	Steering wheel: Not steering (There is no steering force)	0.00 A
			Steering wheel: Steering	0 – 65.00 A (The value is changed according to steering left or right)
MOTOR CURRENT (A)	Consumption current of EPS motor	Engine running	Steering wheel: Not steering (There is no steering force)	0.00 A
			Steering wheel: Steering	0 – 65.00 A ^{*2} (The value is changed according to steering left or right)
VEHICLE SPEED (km/h) or (mph)	Vehicle speed	Vehicle stopped		0 km/h (0 mph)
		While driving		Approximately equal to the indication on speedometer (Inside of ±10%) ^{*3}
WARNING LAMP (ON/OFF)	EPS warning lamp condition	EPS warning lamp: ON		ON
		EPS warning lamp: OFF		OFF
DERATING STAT (ON/OFF)	Protect overload status	Engine running	Steering wheel: Normal steering	OFF
			Steering wheel: Steering over the stop	ON ^{*4}
ENGINE STATUS (RUN/STOP)	Engine status	Engine stopped (Engine speed: Less than 400 rpm)		STOP
		Engine running (Engine speed: 400 rpm or more)		RUN

*1 : In the front of the value, “L” is displayed at steering left and “R” is displayed at steering right.

*2 : Almost in accordance with the value of “MOTOR SIG”. It is not a malfunction though these values are not accorded when steering quickly.

*3 : It is not a malfunction, though it might not be corresponding just after ignition switch is turned ON.

*4 : It turns to OFF after waiting for a short period of time.

TROUBLE DIAGNOSIS

[EPS]

SPECIFICATIONS BETWEEN EPS CONTROL UNIT TERMINALS

EPS Control Unit Terminal Connector Layout

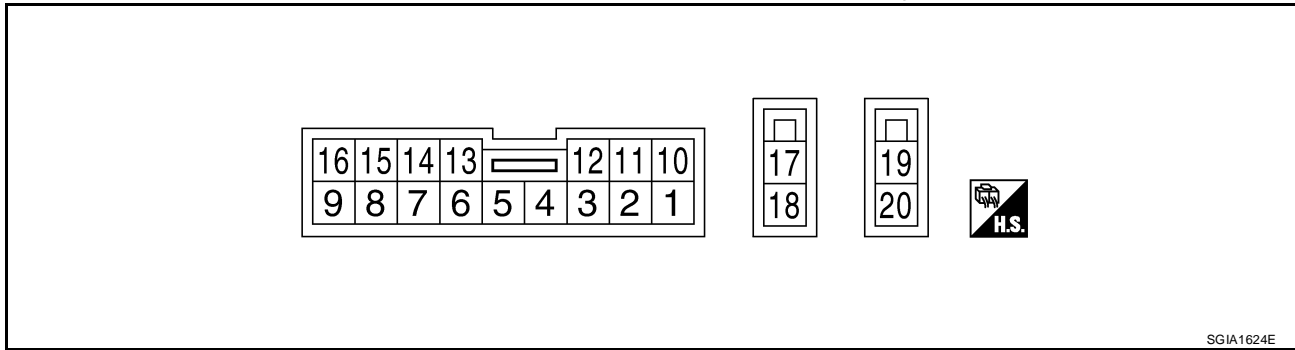

Data are reference value and are measured.

Terminal	Wire color	Item	Condition	Data (Approx.)	
4	V	Torque sensor sub	Engine running	Steering wheel: Not steering (There is no steering force)	2.5 V
				Steering wheel: Steering	1.7 V – 3.3 V (The value is changed according to steering left or right)
5	BR	Torque sensor power supply	Ignition switch: ON		8 V
			Ignition switch: OFF		0 V
6	G	Torque sensor main	Engine running	Steering wheel: Not steering (There is no steering force)	2.5 V
				Steering wheel: Steering	1.7 V – 3.3 V (The value is changed according to steering left or right)
7	R	Torque sensor ground	Always	0 V	
9	L	CAN-H	—	—	
10	O	Power supply	Ignition switch: ON		Battery voltage
			Ignition switch: OFF		0 V
16	P	CAN-L	—	—	
17	R	Power supply (Memory back-up)	Ignition switch: ON		Battery voltage
			Ignition switch: OFF		Battery voltage
18	B	Ground	Always	0 V	
19	—	Motor (+)	—	—	
20	—	Motor (-)	—	—	

CAUTION:

When using a circuit tester to measure voltage for inspection, be sure not to extend forcibly any connector terminals.

CONSULT-II Function (EPS)

FUNCTION

CONSULT-II can display each diagnostic item using the diagnostic test modes shown following.

Diagnostic test mode	Function	Reference page
Self-diagnostic results	<ul style="list-style-type: none"> Self-diagnostic results can be read and erased quickly. 	STC-13
Data monitor	<ul style="list-style-type: none"> Input/Output data in the EPS control unit can be read. 	STC-14
CAN diagnostic support monitor	<ul style="list-style-type: none"> The results of transmit/receive diagnosis of CAN communication can be read. 	LAN-44
ECU part number	<ul style="list-style-type: none"> EPS control unit part number can be read. 	STC-14

CONSULT-II SETTING PROCEDURE

Refer to [GI-38, "CONSULT-II Start Procedure"](#) .

SELF-DIAG RESULTS MODE

Operation Procedure

- Perform "CONSULT-II Start Procedure". Refer to [GI-38, "CONSULT-II Start Procedure"](#) .
- With engine at idle, touch "SELF-DIAG RESULTS". Display shows malfunction experienced since the last erasing operation.

NOTE:

- When malfunction occurred at the same time, it is displayed to a 3 system at the maximum.
 - The details for "TIME" are as follow:
 - "0": Error currently detected with EPS control unit.
 - Except for "0": Error detected in the past and memorized with EPS control unit.
- Detects frequency of driving after DTC occurs (frequency of turning ignition switch "ON").

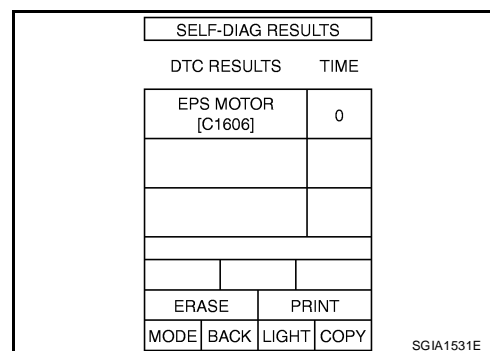

STC

Display Item List

Item (CONSULT-II screen terms)	Diagnostic item is detected when....	Check item
BATTERY VOLT [C1601]	When the power supply malfunction supplied to EPS control unit is detected.	STC-16, "DTC C1601 BATTERY VOLT"
TORQUE SENSOR [C1604]	When the torque sensor malfunction assembled in steering column assembly is detected.	STC-19, "DTC C1604 TORQUE SENSOR"
EPS MOTOR [C1606]	When the motor driver malfunction of EPS control unit or EPS motor malfunction is detected.	STC-21, "DTC C1606 EPS MOTOR"
EEPROM [C1607]	When the memory (EEPROM) system malfunction is detected in EPS control unit.	STC-22, "DTC C1607 EEPROM"
CONTROL UNIT [C1608]	When the internal malfunction is detected in EPS control unit.	STC-22, "DTC C1608 CONTROL UNIT"
CAN VHCL SPEED [C1609]	When the malfunction is detected in vehicle speed signal received with CAN communication.	STC-23, "DTC C1609 CAN VHCL SPEED"
CAN ENG RPM [C1610]	When the malfunction is detected in engine status signal received with CAN communication.	STC-24, "DTC C1610 CAN ENG RPM"
CAN COMM CIRCUIT [U1000]	When EPS control unit is not transmitting or receiving CAN communication signal 2 seconds or more.	STC-24, "DTC U1000 CAN COMM CIRCUIT"
NO DTC IS DETECTED. FURTHER TESTING MAY BE REQUIRED.	No NG item has been detected.	—

CAUTION:

If "CAN COMM CIRCUIT [U1000]" is displayed with other DTCs, first perform the trouble diagnosis for CAN communication line.

How to Erase Self-Diagnostic Results

- Perform applicable inspection of malfunctioning item and then repair or replace.

2. Turn ignition switch "OFF" to erase memory.
3. Turn ignition switch "ON" and select "SELF-DIAG RESULTS" mode with CONSULT-II.
4. Touch "ERASE" on CONSULT-II screen to erase DTC memory.

CAUTION:

If memory cannot be erased, perform diagnosis.

DATA MONITOR

Operation Procedure

1. Perform "CONSULT-II Start Procedure". Refer to [GI-38, "CONSULT-II Start Procedure"](#).
2. Touch "DATA MONITOR".
3. Select from "SELECT MONITOR ITEM", screen of data monitor mode is displayed.

NOTE:

When malfunction is detected, CONSULT-II performs REAL-TIME DIAGNOSIS. Also, any malfunction detected while in this mode will be displayed at real time.

Display Item List

Monitor item (Unit)	Remarks
MOTOR VOL (V)	Power supply voltage for EPS control unit is displayed
TORQUE SENSOR (Nm)	Steering wheel turning force detected by torque sensor is displayed
MOTOR SIG (A)	Current commanded value to EPS motor is displayed
MOTOR CURRENT (A)	Current value consumed by EPS motor is displayed
VEHICLE SPEED (km/h) or (mph)	Vehicle speed is displayed from vehicle speed signal with CAN communication
WARNING LAMP (ON/OFF)	EPS warning lamp control status is displayed
DERATING STAT (ON/OFF)	Protect overload status is displayed
ENGINE STATUS (STOP/RUN)	Engine speed is displayed from engine status signal with CAN communication

EPS CONTROL UNIT PART NUMBER

Display a part number of EPS control unit carried by a vehicle.

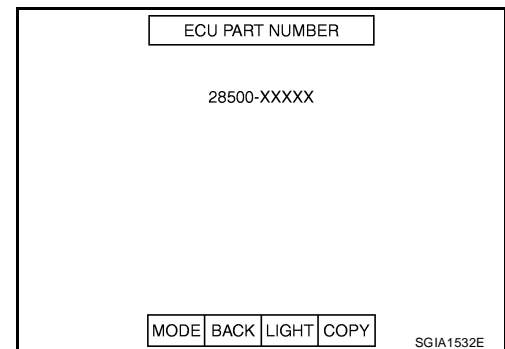

TROUBLE DIAGNOSIS

[EPS]

UGS00081

Symptom Chart

If EPS warning lamp turns ON, perform self-diagnosis. Refer to [STC-13, "SELF-DIAG RESULTS MODE"](#).

Symptom	Condition	Check item	Reference page
EPS warning lamp does not turn ON when ignition switch to "ON". (EPS warning lamp check)	Ignition switch: ON	CAN communication line	STC-26
		Combination meter	
EPS warning lamp does not turn OFF for several seconds after starting the engine	Engine running	CAN communication line	STC-27
		Power supply and ground for EPS control unit	
		Torque sensor	
		EPS motor	
		Vehicle speed signal	
		Engine status signal	
		Combination meter	
Steering wheel turning force is heavy or light, while driving	<ul style="list-style-type: none"> While driving Steering wheel turning 	CAN communication line	STC-29
		Vehicle speed signal	
		Engine status signal	
		EPS motor	
		Steering wheel turning force (Mechanical malfunction)	
Unbalance steering wheel turning force and return between right and left, while driving	<ul style="list-style-type: none"> While driving Steering wheel turning 	Wheel alignment	STC-31
		Steering wheel turning force (Mechanical malfunction)	
Unbalance steering wheel turning force, while driving (Torque variation)	<ul style="list-style-type: none"> While driving Steering wheel turning 	Steering column intermediate shaft installation condition	STC-32
		Steering wheel turning force (Mechanical malfunction)	

A
B
C
D
E
F
H
I
J
K
L
M

STC

TROUBLE DIAGNOSIS FOR SYSTEM

[EPS]

TROUBLE DIAGNOSIS FOR SYSTEM

PF0:0000

DTC C1601 BATTERY VOLT CONSULT-II REFERENCE VALUE IN DATA MONITOR MODE

UGS0008J

Data are reference value.

Monitor item (Unit)	Content	Condition	Display value
MOTOR VOL (V)	Power supply voltage for EPS control unit	Ignition switch: ON	Battery voltage

EPS CONTROL UNIT TERMINALS AND REFERENCE VALUE

Data are reference value and are measured between each terminal and ground.

Terminal	Wire color	Item	Condition	Data (Approx.)
10	O	Power supply	Ignition switch: ON	Battery voltage
			Ignition switch: OFF	0 V
17	R	Power supply (Memory back-up)	Ignition switch: ON	Battery voltage
			Ignition switch: OFF	Battery voltage
18	B	Ground	Always	0 V

CAUTION:

When using a circuit tester to measure voltage for inspection, be sure not to extend forcibly any connector terminals.

DIAGNOSTIC PROCEDURE

1. CHECK EPS CONTROL UNIT POWER SUPPLY CIRCUIT

1. Turn ignition switch "OFF".
2. Disconnect EPS control unit harness connector.
3. Turn ignition switch "ON". (Do not start engine.)
4. Check voltage between EPS control unit harness connector (A) terminals and ground.

Connector	Terminal	Voltage
M53	10 – Ground	Battery voltage
M54	17 – Ground	Battery voltage

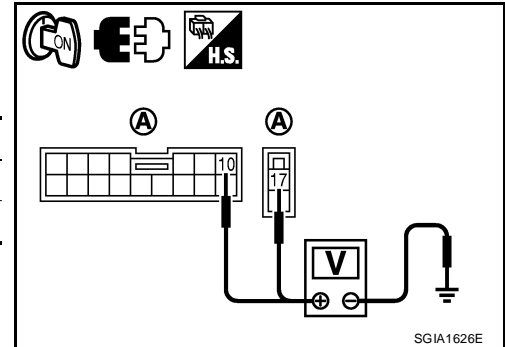

5. Turn ignition switch "OFF".
6. Check voltage between EPS control unit harness connector (A) terminals and ground.

Connector	Terminal	Voltage
M53	10 – Ground	Approx. 0 V
M54	17 – Ground	Battery voltage

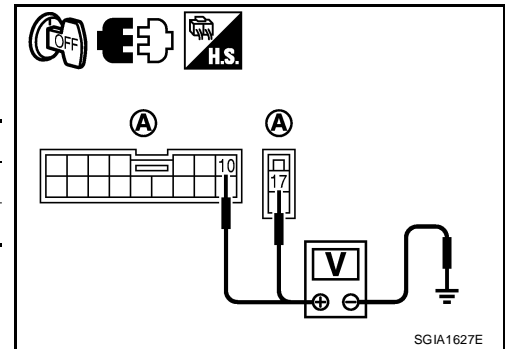

7. Connect EPS control unit harness connector.

OK or NG

- OK >> GO TO 2.
- NG >> Check the following. If any items are damaged, repair or replace damaged parts.
 - 60 A fusible link (No. **m** , located in the fuse and fusible link block). Refer to [PG-4, "POWER SUPPLY ROUTING CIRCUIT"](#) .
 - 10 A fuses (No. 2, located in the fuse block). Refer to [PG-4, "POWER SUPPLY ROUTING CIRCUIT"](#) .
 - Harness for short or open between battery and EPS control unit harness connector M54 terminal 17.
 - Harness for short or open between ignition switch and EPS control unit harness connector M53 terminal 10.

2. CHECK EPS CONTROL UNIT GROUND CIRCUIT

1. Turn ignition switch "OFF".
2. Disconnect EPS control unit harness connector.
3. Check continuity between EPS control unit harness connector (A) terminal and ground.

Connector	Terminal	Continuity
M54	18	Yes

Also check harness for short to power.

4. Connect EPS control unit harness connector.

OK or NG

- OK >> GO TO 3.
- NG >> Repair open circuit or short to ground or short to power in harness or connectors.

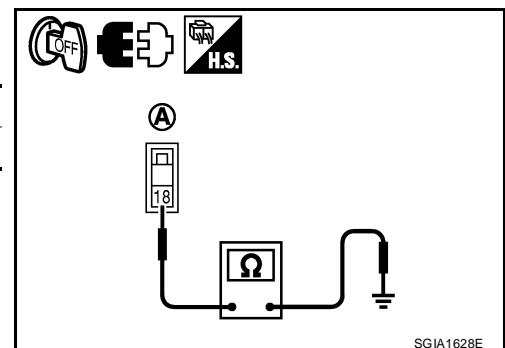

3. CHECK DTC

Start engine.

Does EPS warning lamp turn OFF?

YES >> **INSPECTION END**

NO >> Perform self-diagnosis, repair or replace damaged parts. Refer to [STC-13, "SELF-DIAG RESULTS MODE"](#) .

DTC C1604 TORQUE SENSOR CONSULT-II REFERENCE VALUE IN DATA MONITOR MODE

Data are reference value.

Monitor item (Unit)	Content	Condition	Display value
TORQUE SENSOR (Nm)	Steering wheel turning force	Engine running	Steering wheel: Not steering (There is no steering force)
			Steering wheel: Steering
			0.00 Nm
			0 – 8.19 Nm* (The value is changed according to steering left or right)

*: In the front of the value, "L" is displayed at steering left and "R" is displayed at steering right.

EPS CONTROL UNIT TERMINALS AND REFERENCE VALUE

Data are reference value and are measured between each terminal and ground.

Terminal	Wire color	Item	Condition	Data (Approx.)
4	V	Torque sensor sub	Engine running	Steering wheel: Not steering (There is no steering force)
				Steering wheel: Steering
				2.5 V
				1.7 V – 3.3 V (The value is changed according to steering left or right)
5	BR	Torque sensor power supply	Ignition switch: ON	8 V
			Ignition switch: OFF	0 V
6	G	Torque sensor main	Engine running	Steering wheel: Not steering (There is no steering force)
				Steering wheel: Steering
				2.5 V
				1.7 V – 3.3 V (The value is changed according to steering left or right)
7	R	Torque sensor ground	Always	0 V

CAUTION:

When using a circuit tester to measure voltage for inspection, be sure not to extend forcibly any connector terminals.

DIAGNOSTIC PROCEDURE

1. CHECK TORQUE SENSOR SIGNAL

With CONSULT-II

1. Start engine.
2. Select "DATA MONITOR" mode for "EPS" with CONSULT-II.
3. Check the value of "TORQUE SENSOR". Refer to [STC-11, "SPECIFICATIONS WITH CONSULT-II"](#).

Without CONSULT-II

1. Start engine.
2. Check voltage between EPS control unit harness connector M53 terminals 4, 5, 6, 7 and ground. Refer to [STC-12, "SPECIFICATIONS BETWEEN EPS CONTROL UNIT TERMINALS"](#).

OK or NG

- OK >> GO TO 3.
NG >> GO TO 2.

2. CHECK HARNESS AND CONNECTOR

1. Turn ignition switch "OFF".
2. Disconnect EPS control unit harness connector and torque sensor harness connector.
3. Check continuity between EPS control unit harness connector (A) M53 terminals 4, 5, 6, 7 and torque sensor harness connector (B) M63 terminals 1, 2, 3, 4.

Terminal	Continuity
4 - 3	Yes
5 - 2	
6 - 1	
7 - 4	

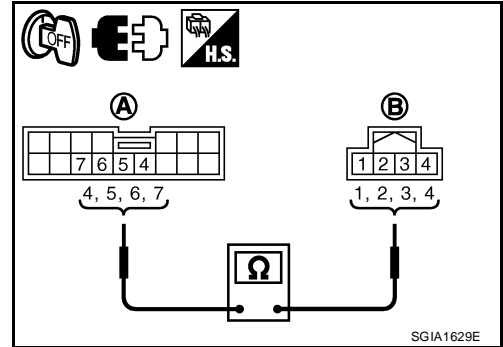

Also check harness for short to ground and short to power.

4. Connect EPS control unit harness connector and torque sensor harness connector.

OK or NG

- OK >> GO TO 3.
- NG >> Repair or replace damaged parts.

3. CHECK EPS CONTROL UNIT

Check EPS control unit input/output signal. Refer to [STC-11, "EPS Control Unit Input/Output Signal Reference Values"](#).

OK or NG

- OK >> GO TO 4.
- NG >> Check EPS control unit pin terminals for damage or loose connection with harness connector. If any items are damaged, repair or replace damaged parts.

4. CHECK DTC

Perform the self-diagnosis, after driving the vehicle for a while.

OK or NG

- OK >> **INSPECTION END**
- NG >> Torque sensor is malfunctioning. Replace steering column assembly. Refer to [PS-9, "Removal and Installation"](#).

DTC C1606 EPS MOTOR

CONSULT-II REFERENCE VALUE IN DATA MONITOR MODE

Data are reference value.

Monitor item (Unit)	Content	Condition	Display value
MOTOR SIG (A)	Command current to EPS motor	Engine running	Steering wheel: Not steering (There is no steering force) 0.00 A
			Steering wheel: Steering 0 – 65.00 A (The value is changed according to steering left or right)
MOTOR CURRENT (A)	Consumption current of EPS motor	Engine running	Steering wheel: Not steering (There is no steering force) 0.00 A
			Steering wheel: Steering 0 – 65.00 A * (The value is changed according to steering left or right)

* : Almost in accordance with the value of "MOTOR SIG". It is not a malfunction though these values are not accorded when steering quickly.

EPS CONTROL UNIT TERMINALS AND REFERENCE VALUE

Data are reference value and are measured between each terminal and ground.

Terminal	Wire color	Item	Condition	Data (Approx.)
19	—	Motor (+)	—	—
20	—	Motor (-)	—	—

CAUTION:

When using a circuit tester to measure voltage for inspection, be sure not to extend forcibly any connector terminals.

DIAGNOSTIC PROCEDURE

1. CHECK EPS MOTOR SIGNAL

④ With CONSULT-II

1. Start engine.
2. Select "DATA MONITOR" mode for "EPS" with CONSULT-II.
3. Check the values of "MOTOR SIG" and "MOTOR CURRENT". Refer to [STC-11, "SPECIFICATIONS WITH CONSULT-II"](#).

OK or NG

- OK >> GO TO 3.
- NG >> GO TO 2.

2. CHECK EPS MOTOR

1. Turn ignition switch "OFF".
2. Disconnect EPS control unit harness connector.
3. Check resistance between EPS control unit harness connector (A) terminals.

Connector	Terminal	Resistance
M60	19 – 20	Approx. 0.1 Ω or less

4. Connect EPS control unit harness connector.

OK or NG

- OK >> GO TO 3.
- NG >> EPS motor is malfunctioning. Replace steering column assembly. Refer to [PS-9, "Removal and Installation"](#).

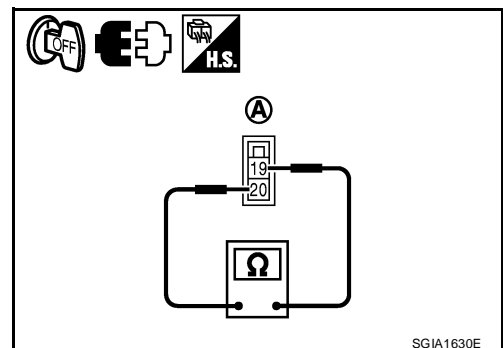

3. CHECK EPS CONTROL UNIT

Check EPS control unit input/output signal. Refer to [STC-11, "EPS Control Unit Input/Output Signal Reference Values"](#) .

OK or NG

- OK >> GO TO 4.
- NG >> Check EPS control unit pin terminals for damage or loose connection with harness connector. If any items are damaged, repair or replace damaged parts.

4. CHECK DTC

Perform the self-diagnosis, after driving the vehicle for a while.

OK or NG

- OK >> **INSPECTION END**
- NG >> GO TO 3.

DTC C1607 EEPROM DIAGNOSTIC PROCEDURE

UGS0008M

1. PERFORM SELF-DIAGNOSIS

With CONSULT-II

1. Turn ignition switch "ON". (Do not start engine.)
2. Select "SELF-DIAG RESULTS" mode for "EPS" with CONSULT-II.
3. Touch "ERASE".
4. Turn ignition switch "OFF", and wait at least 10 seconds.
5. Start engine.
6. Perform the self-diagnosis again.

Is the "EEPROM [C1607]" displayed?

- YES >> Replace EPS control unit. Refer to [PS-9, "Removal and Installation"](#) .
- NO >> **INSPECTION END**

DTC C1608 CONTROL UNIT DIAGNOSTIC PROCEDURE

UGS0008N

1. PERFORM SELF-DIAGNOSIS

With CONSULT-II

1. Turn ignition switch "ON". (Do not start engine.)
2. Select "SELF-DIAG RESULTS" mode for "EPS" with CONSULT-II.
3. Touch "ERASE".
4. Turn ignition switch "OFF", and wait at least 10 seconds.
5. Start engine.
6. Perform the self-diagnosis again.

Is the "CONTROL UNIT [C1608]" displayed?

- YES >> Replace EPS control unit. Refer to [PS-9, "Removal and Installation"](#) .
- NO >> **INSPECTION END**

DTC C1609 CAN VHCL SPEED CONSULT-II REFERENCE VALUE IN DATA MONITOR MODE

Data are reference value.

Monitor item (Unit)	Content	Condition	Display value
VEHICLE SPEED (km/h) or (mph)	Vehicle speed	Vehicle stopped	0 km/h (0 mph)
		While driving	Approximately equal to the indication on speedometer (Inside of ±10%)

* : It is not a malfunction, though it might not be corresponding just after ignition switch is turned ON.

DIAGNOSTIC PROCEDURE

1. CHECK DTC WITH COMBINATION METER

Perform self-diagnosis with combination meter. Refer to [DI-14, "SELF-DIAGNOSTIC RESULTS"](#) .

Is any malfunction detected by self-diagnosis?

- YES >> Check the malfunctioning system.
- NO-1 >> With ABS: GO TO 2.
- NO-2 >> Without ABS: GO TO 3.

2. CHECK DTC WITH ABS ACTUATOR AND ELECTRIC UNIT (CONTROL UNIT)

Perform self-diagnosis with ABS actuator and electric unit (control unit). Refer to [BRC-20, "SELF-DIAGNOSIS"](#) .

Is any malfunction detected by self-diagnosis?

- YES >> Check the malfunctioning system.
- NO >> GO TO 4.

3. CHECK DTC WITH TRANSMISSION CONTROL MODULE (TCM)

Perform self-diagnosis with TCM. Refer to [AT-82, "SELF-DIAGNOSTIC RESULT MODE"](#) .

Is any malfunction detected by self-diagnosis?

- YES >> Check the malfunctioning system.
- NO >> GO TO 4.

4. CHECK EPS CONTROL UNIT

Check EPS control unit input/output signal. Refer to [STC-11, "EPS Control Unit Input/Output Signal Reference Values"](#) .

OK or NG

- OK >> GO TO 5.
- NG >> Check EPS control unit pin terminals for damage or loose connection with harness connector. If any items are damaged, repair or replace damaged parts.

5. CHECK DTC

Perform the self-diagnosis, after driving the vehicle for a while.

OK or NG

- OK >> **INSPECTION END**
- NG >> Perform self-diagnosis with ABS actuator and electric unit (control unit) and combination meter. Refer to [BRC-20, "SELF-DIAGNOSIS"](#) , [DI-14, "SELF-DIAGNOSTIC RESULTS"](#) .

DTC C1610 CAN ENG RPM

UGS0008P

CONSULT-II REFERENCE VALUE IN DATA MONITOR MODE

Data are reference value.

Monitor item (Unit)	Content	Condition	Display value
ENGINE STATUS (RUN/STOP)	Engine status	Engine stopped (Engine speed: Less than 400 rpm)	STOP
		Engine running (Engine speed: 400 rpm or more)	RUN

DIAGNOSTIC PROCEDURE

1. CHECK DTC WITH ECM

Perform self-diagnosis with ECM. Refer to [EC-116, "SELF-DIAG RESULTS MODE"](#) .

Is any malfunction detected by self-diagnosis?

- YES >> Check the malfunctioning system.
- NO >> GO TO 2.

2. CHECK EPS CONTROL UNIT

Check EPS control unit input/output signal. Refer to [STC-11, "EPS Control Unit Input/Output Signal Reference Values"](#) .

OK or NG

- OK >> GO TO 3.
- NG >> Check EPS control unit pin terminals for damage or loose connection with harness connector. If any items are damaged, repair or replace damaged parts.

3. CHECK DTC

Perform the self-diagnosis, after driving a vehicle for a while.

OK or NG

- OK >> **INSPECTION END**
- NG >> Perform self-diagnosis with ECM again. Refer [EC-116, "SELF-DIAG RESULTS MODE"](#) .

DTC U1000 CAN COMM CIRCUIT

UGS0008Q

DIAGNOSTIC PROCEDURE

1. CHECK CAN COMMUNICATION CIRCUIT

With CONSULT-II

1. Turn ignition switch "ON" and start engine.
2. Select "SELF-DIAG RESULTS" mode for "EPS" with CONSULT-II.
3. Perform the self-diagnosis.

Is the "CAN COMM CIRCUIT [U1000]" displayed?

- YES >> Print out CONSULT-II screen and go to [LAN-47, "CAN System Specification Chart"](#) .
- NO >> **INSPECTION END**

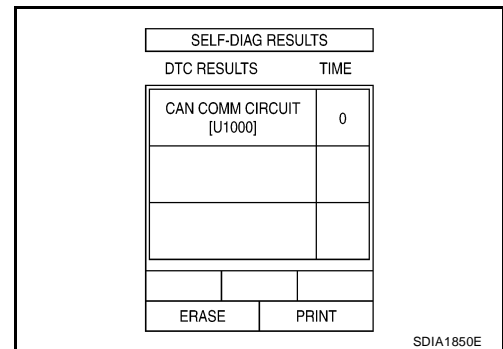

Component Inspection EPS MOTOR

1. Turn ignition switch "OFF".
2. Disconnect EPS control unit harness connector.
3. Check resistance between EPS control unit harness connector (A) terminals.

Connector	Terminal	Resistance
M60	19 – 20	Approx. 0.1 Ω or less

4. If NG, replace the steering column assembly. Refer to [PS-9, "Removal and Installation"](#).

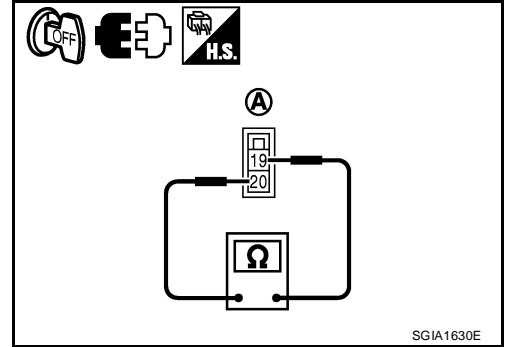

A
B
C
D
E
F
H
I
J
K
L
M

STC

TROUBLE DIAGNOSIS FOR SYMPTOMS

EPS Warning Lamp Does Not Turn ON SYMPTOM:

EPS warning lamp does not turn ON when ignition switch to "ON".

DIAGNOSTIC PROCEDURE

1. CHECK SYSTEM FOR CAN COMMUNICATION LINE

Perform self-diagnosis. Refer to [STC-13, "SELF-DIAG RESULTS MODE"](#) .

Is the "CAN COMM CIRCUIT [U1000]" displayed?

YES >> Perform trouble diagnosis for CAN communication line. Refer to [STC-24, "DTC U1000 CAN COMM CIRCUIT"](#) .

NO >> GO TO 2.

2. CHECK EPS CONTROL UNIT

Check EPS control unit input/output signal. Refer to [STC-11, "EPS Control Unit Input/Output Signal Reference Values"](#) .

OK or NG

OK >> GO TO 3.

NG >> Check EPS control unit pin terminals for damage or loose connection with harness connector. If any items are damaged, repair or replace damaged parts.

3. SYMPTOM CHECK

Check again.

OK or NG

OK >> **INSPECTION END**

NG >> Replace combination meter. Refer to [DI-23, "Removal and Installation"](#) .

EPS Warning Lamp Does Not Turn OFF

SYMPTOM:

EPS warning lamp does not turn OFF for several seconds after starting the engine.

DIAGNOSTIC PROCEDURE

1. CHECK SELF-DIAGNOSTIC RESULTS

Perform self-diagnosis. Refer to [STC-13, "SELF-DIAG RESULTS MODE"](#) .

Is any malfunction detected by self-diagnosis?

- YES >> Check the malfunctioning system.
- NO >> GO TO 2.

2. CHECK EPS CONTROL UNIT POWER SUPPLY CIRCUIT

1. Turn ignition switch "OFF".
2. Disconnect EPS control unit harness connector.
3. Turn ignition switch "ON". (Do not start engine.)
4. Check voltage between EPS control unit harness connector (A) terminals and ground.

Connector	Terminal	Voltage
M53	10 – Ground	Battery voltage
M54	17 – Ground	Battery voltage

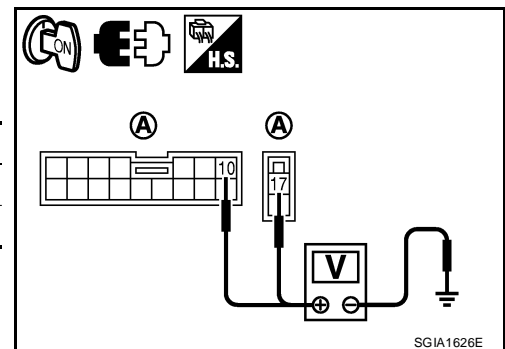

5. Turn ignition switch "OFF".
6. Check voltage between EPS control unit harness connector (A) terminals and ground.

Connector	Terminal	Voltage
M53	10 – Ground	Approx. 0 V
M54	17 – Ground	Battery voltage

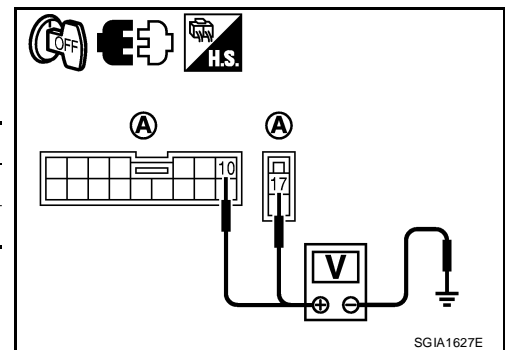

7. Connect EPS control unit harness connector.

OK or NG

- OK >> GO TO 3.
- NG >> Check the following. If any items are damaged, repair or replace damaged parts.
 - 60 A fusible link (No. **m** , located in the fuse and fusible link block). Refer to [PG-4, "POWER SUPPLY ROUTING CIRCUIT"](#) .
 - 10 A fuses (No. 2, located in the fuse block). Refer to [PG-4, "POWER SUPPLY ROUTING CIRCUIT"](#) .
 - Harness for short or open between battery and EPS control unit harness connector M54 terminal 17.
 - Harness for short or open between ignition switch and EPS control unit harness connector M53 terminal 10.

3. CHECK EPS CONTROL UNIT GROUND CIRCUIT

1. Turn ignition switch "OFF".
2. Disconnect EPS control unit harness connector.
3. Check continuity between EPS control unit harness connector (A) terminal and ground.

Connector	Terminal	Continuity
M54	18	YES

Also check harness for short to power.

4. Connect EPS control unit harness connector.

OK or NG

OK >> GO TO 4.

NG >> Repair open circuit or short to ground or short to power in harness or connectors.

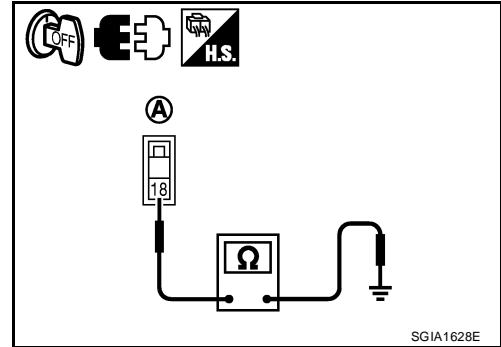

4. CHECK EPS CONTROL UNIT

Check EPS control unit input/output signal. Refer to [STC-11, "EPS Control Unit Input/Output Signal Reference Values"](#) .

OK or NG

OK >> GO TO 5.

NG >> Check EPS control unit pin terminals for damage or loose connection with harness connector. If any items are damaged, repair or replace damaged parts.

5. SYMPTOM CHECK

Check again.

OK or NG

OK >> **INSPECTION END**

NG >> Replace combination meter. Refer to [DI-23, "Removal and Installation"](#) .

Steering Wheel Turning Force is Heavy or Light**SYMPTOM:**

Steering wheel turning force is heavy or light, while driving.

DIAGNOSTIC PROCEDURE**1. CHECK SYSTEM FOR CAN COMMUNICATION LINE**

Perform self-diagnosis. Refer to [STC-13, "SELF-DIAG RESULTS MODE"](#) .

Is the "CAN COMM CIRCUIT [U1000]" displayed?

YES >> Perform trouble diagnosis for CAN communication line. Refer to [STC-24, "DTC U1000 CAN COMM CIRCUIT"](#) .

NO-1 >> With ABS: GO TO 2.

NO-2 >> Without ABS: GO TO 3.

2. CHECK VEHICLE SPEED SIGNAL FROM ABS ACTUATOR AND ELECTRIC UNIT (CONTROL UNIT)

Perform self-diagnosis with ABS actuator and electric unit (control unit). Refer to [BRC-20, "SELF-DIAGNOSIS"](#) .

Is any malfunction detected by self-diagnosis?

YES >> Check the malfunctioning system.

NO >> GO TO 4.

3. CHECK VEHICLE SPEED SIGNAL FROM TRANSMISSION CONTROL MODULE (TCM)

Perform self-diagnosis with TCM. Refer to [AT-82, "SELF-DIAGNOSTIC RESULT MODE"](#) .

Is any malfunction detected by self-diagnosis?

YES >> Check the malfunctioning system.

NO >> GO TO 4.

4. CHECK COMBINATION METER SIGNAL

Perform self-diagnosis with combination meter. Refer to [DI-14, "SELF-DIAGNOSTIC RESULTS"](#) .

Is any malfunction detected by self-diagnosis?

YES >> Check the malfunctioning system.

NO >> GO TO 5.

5. CHECK ENGINE STATUS SIGNAL

Perform self-diagnosis for ECM. Refer to [EC-116, "SELF-DIAG RESULTS MODE"](#) .

Is any malfunction detected by self-diagnosis?

YES >> Check the malfunctioning system.

NO >> GO TO 6.

6. CHECK EPS MOTOR SYSTEM

Perform trouble diagnosis for EPS motor. Refer to [STC-21, "DTC C1606 EPS MOTOR"](#) .

OK or NG

OK >> GO TO 7.

NG >> Repair or replace damaged parts.

7. CHECK EPS CONTROL UNIT

Check EPS control unit input/output signal. Refer to [STC-11, "EPS Control Unit Input/Output Signal Reference Values"](#) .

OK or NG

OK >> GO TO 8.

NG >> Check EPS control unit pin terminals for damage or loose connection with harness connector. If any items are damaged, repair or replace damaged parts.

8. SYMPTOM CHECK

Check again.

OK or NG

OK >> **INSPECTION END**

NG >> Check the steering wheel turning force because there may be mechanical malfunction. Refer to [PS-6, "CHECKING STEERING WHEEL TURNING FORCE"](#).

Unbalance Steering Wheel Turning Force and Return Between Right and Left**SYMPTOM:**

Unbalance steering wheel turning force and return between right and left, while driving.

DIAGNOSTIC PROCEDURE**1. CHECK EPS WARNING LAMP**

Confirm EPS warning lamp during engine running.

Does EPS warning lamp turn OFF?

YES >> GO TO 2.

NO >> Go to [STC-27, "EPS Warning Lamp Does Not Turn OFF"](#) .

2. CHECK WHEEL ALIGNMENT

Check wheel alignment. Refer to [FSU-6, "Wheel Alignment Inspection"](#) .

OK or NG

OK >> GO TO 3.

NG >> Adjust wheel alignment. Refer to [FSU-6, "Wheel Alignment Inspection"](#) .

3. CHECK EPS CONTROL UNIT

Check EPS control unit input/output signal. Refer to [STC-11, "EPS Control Unit Input/Output Signal Reference Values"](#) .

OK or NG

OK >> GO TO 4.

NG >> Check EPS control unit pin terminals for damage or loose connection with harness connector. If any items are damaged, repair or replace damaged parts.

4. SYMPTOM CHECK

Check again.

OK or NG

OK >> **INSPECTION END**

NG >> Check the steering wheel turning force because there may be mechanical malfunction. Refer to [PS-6, "CHECKING STEERING WHEEL TURNING FORCE"](#) .

A

B

C

D

E

F

STC

H

I

J

K

L

M

Unbalance Steering Wheel Turning Force (Torque Variation)

SYMPTOM:

Unbalance steering wheel turning force, while driving (Torque variation).

DIAGNOSTIC PROCEDURE

1. CHECK EPS WARNING LAMP

Confirm EPS warning lamp during engine running.

Does EPS warning lamp turn OFF?

YES >> GO TO 2.

NO >> Go to [STC-27, "EPS Warning Lamp Does Not Turn OFF"](#) .

2. CHECK STEERING COLUMN INTERMEDIATE SHAFT

Check the connection between intermediate shaft and the mounting part of steering column assembly and steering gear assembly. Refer to [PS-9, "COMPONENT"](#) .

OK or NG

OK >> GO TO 3.

NG >> Repair or replace damaged parts.

3. CHECK EPS CONTROL UNIT

Check EPS control unit input/output signal. Refer to [STC-11, "EPS Control Unit Input/Output Signal Reference Values"](#) .

OK or NG

OK >> GO TO 4.

NG >> Check EPS control unit pin terminals for damage or loose connection with harness connector. If any items are damaged, repair or replace damaged parts.

4. SYMPTOM CHECK

Check again.

OK or NG

OK >> **INSPECTION END**

NG >> Check the steering wheel turning force because there may be mechanical malfunction. Refer to [PS-6, "CHECKING STEERING WHEEL TURNING FORCE"](#) .