

SECTION **RAX**  
REAR AXLE

A  
B  
C

RAX

CONTENTS

E

<b>PREPARATION</b> .....	2	REAR WHEEL BEARING INSPECTION	4	F
Commercial Service Tools .....	2	Removal and Installation .....	4	
<b>NOISE, VIBRATION AND HARSHNESS (NVH)</b>		COMPONENTS .....	4	
<b>TROUBLESHOOTING</b> .....	3	REMOVAL .....	4	G
NVH Troubleshooting Chart .....	3	INSPECTION AFTER REMOVAL .....	5	
<b>WHEEL HUB</b> .....	4	INSTALLATION .....	5	
On-Vehicle Inspection and Service .....	4	<b>SERVICE DATA AND SPECIFICATIONS (SDS)</b> .....	6	H
		Wheel Bearing .....	6	

I

J

K

L

M

# PREPARATION

## PREPARATION

PF0:00002

### Commercial Service Tools

EDS0030Y

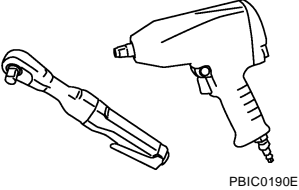
Tool name	Description
Power tool  PBIC0190E	Removing wheel nuts

# NOISE, VIBRATION AND HARSHNESS (NVH) TROUBLESHOOTING

## NOISE, VIBRATION AND HARSHNESS (NVH) TROUBLESHOOTING

PF0:00003

### NVH Troubleshooting Chart

EDS003QZ

Use chart below to help you find the cause of the symptom. If necessary, repair or replace these parts.

Reference page			<a href="#">RAX-4</a>	—	<a href="#">RAX-4</a>	NVH in RAX and RSU sections.	NVH in WT section.	NVH in WT section.	NVH in BR section.	NVH in PS section.	
Possible cause and SUSPECTED PARTS			Improper installation, looseness	Parts interference	Wheel bearing damage	REAR AXLE AND REAR SUSPENSION	TIRES	ROAD WHEEL	BRAKES	STEERING	
Symptom	REAR AXLE	Noise	x	x		x	x	x	x	x	
		Shake	x	x		x	x	x	x	x	
		Vibration	x	x		x	x				x
		Shimmy	x	x		x	x	x	x	x	x
		Judder	x			x	x	x	x	x	x
		Poor quality ride or handling	x	x	x	x	x	x	x		

x: Applicable

A  
B  
C  
RAX  
E  
F  
G  
H  
I  
J  
K  
L  
M

# WHEEL HUB

PF:43202

## WHEEL HUB

### On-Vehicle Inspection and Service

EDS003R0

- Check the axle and suspension parts for excessive play, wear, or damage.
- Shake each rear wheel to check for excessive play as shown.

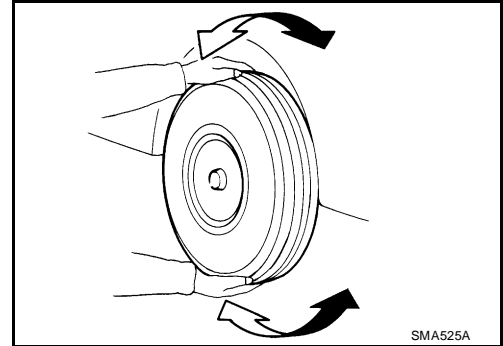

### REAR WHEEL BEARING INSPECTION

- Move wheel hub and bearing assembly in the axial direction by hand. Make sure the axial end play is within specification.

**Axial end play : 0.05 mm (0.002 in) or less**

- Check that the wheel hub bearing operates smoothly.
- Replace the wheel hub assembly if the axial end play exceeds specification, or if the wheel bearing does not turn smoothly. Refer to [RAX-4, "Removal and Installation"](#).

#### CAUTION:

The wheel hub assembly does not require maintenance. If any of the following symptoms are noted, replace the wheel hub assembly.

- Growling noise is emitted from the wheel hub bearing during operation.
- Wheel hub bearing drags or turns roughly.

### Removal and Installation COMPONENTS

EDS003R1

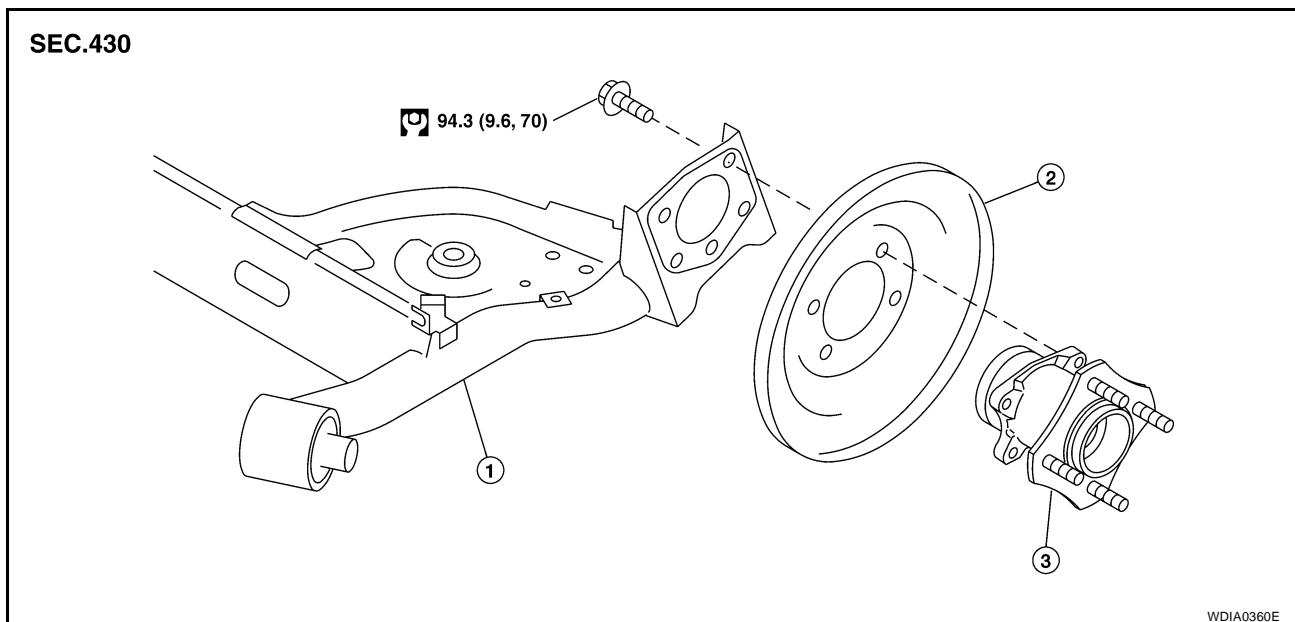

1. Rear suspension beam

2. Back plate

3. Wheel hub and bearing assembly

### REMOVAL

1. Remove tires from vehicle using power tool.
2. Remove wheel sensor from wheel hub and bearing assembly. Refer to [BRC-33, "WHEEL SENSORS"](#).

# WHEEL HUB

---

**CAUTION:**

**Do not pull on wheel sensor harness.**

3. Remove the drum brake assembly. Refer to [BR-31, "Removal and Installation of Drum Brake Assembly"](#) .
4. Remove wheel hub and bearing assembly bolts, and then remove wheel hub and bearing assembly from vehicle.
5. If necessary remove back plate, following procedure.
  1. Remove parking brake rear cable from back plate. Refer to [PB-4, "PARKING BRAKE CONTROL"](#) .
  2. Separate brake tube from wheel cylinder. Refer to [BR-11, "BRAKE TUBE AND HOSE"](#) .

## INSPECTION AFTER REMOVAL

Check for any deformity, cracks, or other damage on the wheel hub assembly, replace if necessary.

**CAUTION:**

**The wheel hub assembly does not require maintenance. If any of the following symptoms are noted, replace the wheel hub assembly.**

- **Growling noise is emitted from the wheel hub bearing during operation.**
- **Wheel hub bearing drags or turns roughly.**

## INSTALLATION

Installation is in the reverse order of removal.

A

B

C

RAX

E

F

G

H

I

J

K

L

M

# SERVICE DATA AND SPECIFICATIONS (SDS)

---

## SERVICE DATA AND SPECIFICATIONS (SDS)

PF0:00030

### Wheel Bearing

EDS003R2

---

Axial end play	0.05 mm (0.002 in) or less
----------------	----------------------------

---