

A
B
C

SECTION PS

POWER STEERING SYSTEM

CONTENTS

<p>PRECAUTIONS 2</p> <p> Precautions for Supplemental Restraint System (SRS) "AIR BAG" and "SEAT BELT PRE-TENSIONER" 2</p> <p> Precautions Necessary for Steering Wheel Rotation After Battery Disconnect 2</p> <p> OPERATION PROCEDURE 2</p> <p> Precautions for Steering System 3</p> <p>PREPARATION 4</p> <p> Special Service Tools 4</p> <p> Commercial Service Tools 4</p> <p>NOISE, VIBRATION AND HARSHNESS (NVH)</p> <p>TROUBLESHOOTING 5</p> <p> NVH Trouble Shooting Chart 5</p> <p>STEERING WHEEL 6</p> <p> On-Vehicle Inspection and Service 6</p> <p> CHECKING CONDITION OF INSTALLATION 6</p> <p> CHECKING STEERING WHEEL PLAY 6</p> <p> CHECKING NEUTRAL POSITION STEERING WHEEL 6</p> <p> CHECKING STEERING WHEEL TURNING FORCE 6</p> <p> CHECKING FRONT WHEEL TURNING ANGLE... 7</p> <p> Removal and Installation 8</p> <p> REMOVAL 8</p> <p> INSTALLATION 8</p>	<p>STEERING COLUMN 9</p> <p> Removal and Installation 9</p> <p> COMPONENT 9</p> <p> REMOVAL 9</p> <p> INSPECTION AFTER REMOVAL 10</p> <p> INSTALLATION 10</p> <p> INSPECTION AFTER INSTALLATION 10</p> <p>POWER STEERING GEAR 12</p> <p> Removal and Installation 12</p> <p> COMPONENT 12</p> <p> REMOVAL 12</p> <p> INSTALLATION 12</p> <p> INSPECTION AFTER INSTALLATION 13</p> <p> Disassembly and Assembly 13</p> <p> COMPONENT (R24K TYPE) 13</p> <p> DISASSEMBLY 13</p> <p> INSPECTION AFTER DISASSEMBLY 14</p> <p> ASSEMBLY 15</p> <p>SERVICE DATA AND SPECIFICATIONS (SDS) 17</p> <p> Steering Wheel 17</p> <p> Steering Angle 17</p> <p> Steering Column 17</p> <p> Steering Outer Socket and Inner Socket 17</p> <p> Steering Gear 18</p>
---	---

F
PS
H
I
J
K
L
M

PRECAUTIONS

PRECAUTIONS

PF0:00001

Precautions for Supplemental Restraint System (SRS) “AIR BAG” and “SEAT BELT PRE-TENSIONER”

EGS0015S

The Supplemental Restraint System such as “AIR BAG” and “SEAT BELT PRE-TENSIONER”, used along with a front seat belt, helps to reduce the risk or severity of injury to the driver and front passenger for certain types of collision. This system includes seat belt switch inputs and dual stage front air bag modules. The SRS system uses the seat belt switches to determine the front air bag deployment, and may only deploy one front air bag, depending on the severity of a collision and whether the front occupants are belted or unbelted. Information necessary to service the system safely is included in the SRS and SB section of this Service Manual.

WARNING:

- To avoid rendering the SRS inoperative, which could increase the risk of personal injury or death in the event of a collision which would result in air bag inflation, all maintenance must be performed by an authorized NISSAN/INFINITI dealer.
- Improper maintenance, including incorrect removal and installation of the SRS, can lead to personal injury caused by unintentional activation of the system. For removal of Spiral Cable and Air Bag Module, see the SRS section.
- Do not use electrical test equipment on any circuit related to the SRS unless instructed to in this Service Manual. SRS wiring harnesses can be identified by yellow and/or orange harnesses or harness connectors.

Precautions Necessary for Steering Wheel Rotation After Battery Disconnect

EGS0014Q

NOTE:

- This procedure is applied only to models with Intelligent Key system and NATS (NISSAN ANTI-THEFT SYSTEM).
- Remove and install all control units after disconnecting both battery cables with the ignition switch in the “LOCK” position.
- Always use CONSULT-II to perform self-diagnosis as a part of each function inspection after finishing work. If DTC is detected, perform trouble diagnosis according to self-diagnostic results.

For models equipped with the Intelligent Key system and NATS, an electrically controlled steering lock mechanism is adopted on the key cylinder.

For this reason, if the battery is disconnected or if the battery is discharged, the steering wheel will lock and steering wheel rotation will become impossible.

If steering wheel rotation is required when battery power is interrupted, follow the procedure below before starting the repair operation.

OPERATION PROCEDURE

1. Connect both battery cables.

NOTE:

Supply power using jumper cables if battery is discharged.

2. Use the Intelligent Key or mechanical key to turn the ignition switch to the “ACC” position. At this time, the steering lock will be released.
3. Disconnect both battery cables. The steering lock will remain released and the steering wheel can be rotated.
4. Perform the necessary repair operation.
5. When the repair work is completed, return the ignition switch to the “LOCK” position before connecting the battery cables. (At this time, the steering lock mechanism will engage.)
6. Perform a self-diagnosis check of all control units using CONSULT-II.

PRECAUTIONS

Precautions for Steering System

EGS0014R

- In case of removing steering gear assembly, make the final tightening with grounded and unloaded vehicle condition, and then check wheel alignment.
- Observe the following precautions when disassembling.
 - Before disassembly, thoroughly clean the outside of the unit.
 - Disassembly should be done in a clean work area. It is important to prevent the internal parts from becoming contaminated by dirt or other foreign matter.
 - For easier and proper assembly, place disassembled parts in order on a parts rack.
 - Use nylon cloth or paper towels to clean the parts; common shop rags can leave lint that might interfere with their operation.
 - Do not reuse non-reusable parts.
 - Before assembling, apply the specified grease to the directed parts.

A

B

C

D

E

F

PS

H

I

J

K

L

M

PREPARATION

PFP:00002

PREPARATION

Special Service Tools

EGS0014S

The actual shapes of Kent-Moore tools may differ from those of special tools illustrated here.

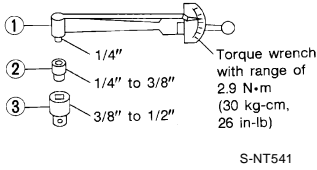
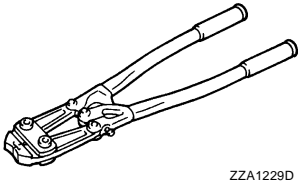
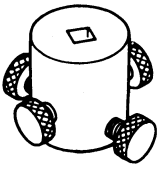
Tool number (Kent-Moore No.) Tool name	Description
ST3127S000 (J-25742-1) Preload gauge (J-25765-A) 1. GG91030000 Torque wrench 2. HT62940000 (—) Socket adapter (1/2") 3. HT62900000 (—) Socket adapter (3/8")	Inspecting rotating torque for steering column assembly and pinion assembly 
KV40107300 (—) Boot Band crimping tool	Installing boot bands 
KV48103400 (—) Preload adapter	Inspecting of rotating torque for pinion assembly 

Commercial Service Tools

EGS0014T

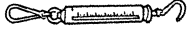
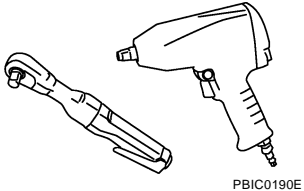
Tool number Tool name	Description
Spring gauge	Inspecting steering wheel turning force and power steering gear linkage 
Power tool	Removing nuts and bolts 

NOISE, VIBRATION AND HARSHNESS (NVH) TROUBLESHOOTING

NOISE, VIBRATION AND HARSHNESS (NVH) TROUBLESHOOTING

PF0:00003

NVH Trouble Shooting Chart

EGS0014U

Use chart below to help you find the cause of the symptom. If necessary, repair or replace these parts.

Symptom		Possible cause and SUSPECTED PARTS														Reference page		
		Outer/Inner socket ball joint swinging torque	Outer/Inner socket ball joint end play	Steering wheel play	Steering gear pinion rotating torque	Improper steering wheel	Improper installation or looseness of tilt lock lever	Mounting looseness	Steering column deformation or damage	Improper installation or looseness of steering column	Steering linkage looseness	WHEEL HUB	SUSPENSION	TIRES	ROAD WHEEL		DRIVE SHAFT	BRAKES
Noise	Noise	x	x	x	x							x	x	x	x	x	x	PS-14
	Shake					x	x	x				x	x	x	x	x		PS-14
	Vibration					x	x	x	x	x		x	x	x				PS-6
	Shimmy					x	x	x				x	x	x	x			PS-6
	Shudder							x				x	x	x	x			PS-6
																		PS-10
																		PS-12, PS-13
																		PS-10
																		PS-9
																		PS-13
																		FAX-4, "NVH Troubleshooting Chart"
																		FSU-5, "NVH Troubleshooting Chart"
																		WT-4, "NVH Troubleshooting Chart"
																		WT-4, "NVH Troubleshooting Chart"
																		FAX-4, "NVH Troubleshooting Chart"
																		BR-5, "NVH Troubleshooting Chart"

x: Applicable

A
B
C
D
E
F
PS
H
I
J
K
L
M

STEERING WHEEL

STEERING WHEEL

PF:48430

On-Vehicle Inspection and Service CHECKING CONDITION OF INSTALLATION

EGS0014V

- Check installation conditions of steering gear assembly, front suspension assembly, axle and steering column assembly.
- Check if movement exists when steering wheel is moved up and down, to the left and right and to the axial direction.

Steering wheel axial end play : 0 mm (0 in)

- Check steering gear assembly mounting bolts and nuts for looseness. Refer to [PS-12, "COMPONENT"](#) .

CHECKING STEERING WHEEL PLAY

- Turn steering wheel so that front wheels come to the straight-ahead position. Start engine and lightly turn steering wheel to the left and right until front wheels start to move. Measure steering wheel movement on the outer circumference.

Steering wheel play : 0 - 35 mm (0 - 1.38 in)

- When the measurement value is outside the standard value, check backlash for each joint of steering column assembly and installation condition of steering gear assembly.

CHECKING NEUTRAL POSITION STEERING WHEEL

- Make sure that steering gear assembly, steering column assembly and steering wheel are installed in the correct position.
- Perform neutral position inspection after wheel alignment. Refer to [RSU-2, "Precautions for Supplemental Restraint System \(SRS\) "AIR BAG" and "SEAT BELT PRE-TENSIONER" "](#) .
- Set vehicle to the straight-ahead position and confirm steering wheel is in the neutral position.
- Loosen outer socket lock nut and turn inner socket to left and right equally to make fine adjustments if steering wheel is not in the neutral position.

CHECKING STEERING WHEEL TURNING FORCE

1. Park vehicle on a level and dry surface, set parking brake.
2. Start engine.
3. Check steering wheel turning force when steering wheel has been turned 360° from neutral position using suitable tool as shown.

Steering wheel turning force : Less than 36 N (3.7 kg-f, 8.2 lb-f)

4. If steering wheel turning force is out of the specification, refer to [STC-7, "How to Perform Trouble Diagnosis"](#) .

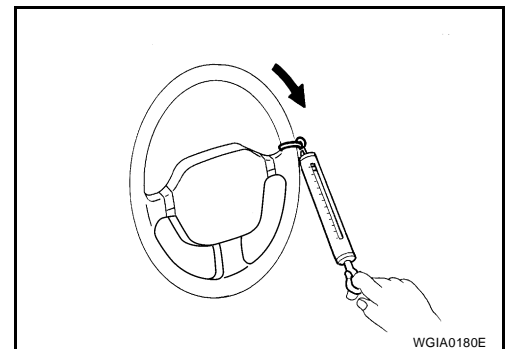

STEERING WHEEL

CHECKING FRONT WHEEL TURNING ANGLE

- Check front wheel turning angle after toe-in inspection. Place front wheels on turning radius gauges and rear wheels on stands. Check the maximum inner and outer wheel turning angles for LH and RH road wheels.

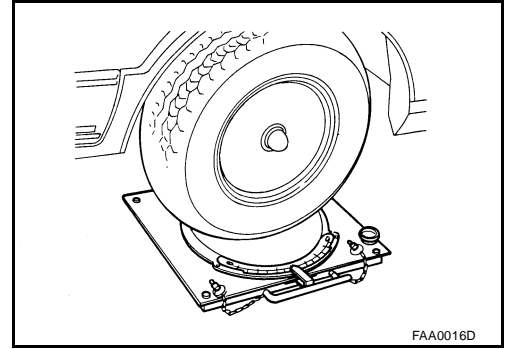

- With the engine at idle, turn steering wheel from full left stop to full right stop and measure the turning angles.

Inner wheel (Angle: A)	Minimum	35° 00' (35.0°)
	Nominal	38° 00' (38.0°)
	Maximum	39° 00' (39.0°)
Outer wheel (Angle: B)		33° 00' (33.0°)

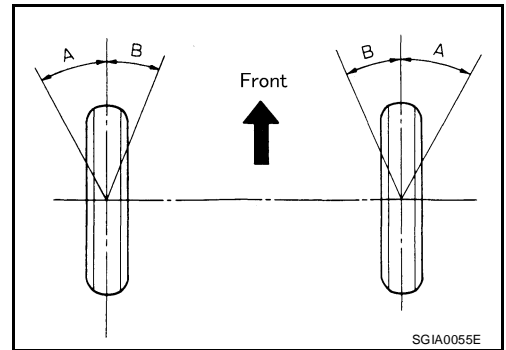

- Measure rack stroke if angles are outside the specified value.

Rack stroke "L" : 65.0 mm (2.559 in)

- Disassemble steering gear assembly to check the cause that rack stroke is outside of the standard.
- Steering angles are not adjustable. Check steering gear assembly, steering column assembly and front suspension components for wear or damage if any of the turning angles are different from the specified value. Replace any of them, if any non-standard condition exists.

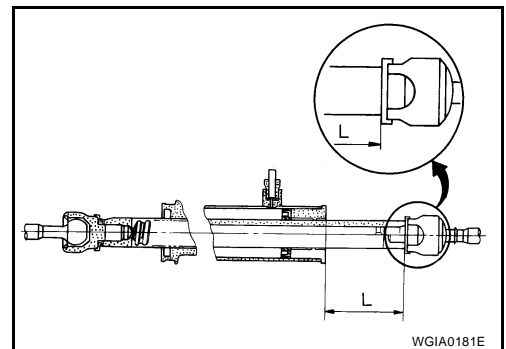

STEERING WHEEL

EGS0014W

Removal and Installation

REMOVAL

NOTE:

When reconnecting spiral cable, secure cable with a tape so that case and rotating part keep aligned. This will omit neutral position alignment procedure during spiral cable installation.

1. Set vehicle to the straight-ahead position.
2. Remove driver air bag module. Refer to [SRS-41, "DRIVER AIR BAG MODULE"](#) .
3. Remove steering wheel lock nut after steering is locked.
4. Remove steering wheel.

INSTALLATION

Installation is in the reverse order of removal.

CAUTION:

Do not run spiral cable idle needlessly. And do not turn it more than necessary (or it leads to disconnection of the cable).

NOTE:

- The neutral position is set as follows.
Turn the spiral cable clockwise to the end position. Then turn it counterclockwise (about 2 and half turns) and stop turning at the point on which the stopper insertion holes are in the same position (B). The service part is installed in the neutral position by the stopper and can be set without adjusting after the stopper is removed.
- Adjust the spiral cable locating pin (B) to the steering wheel locating pin hole (C).

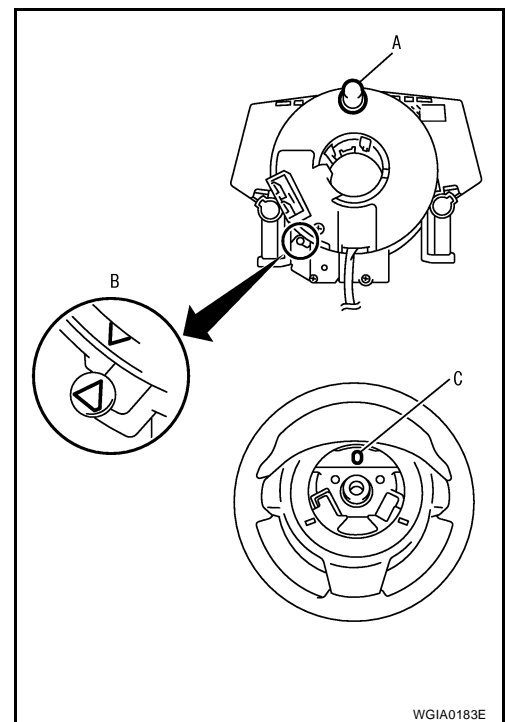

WGIA0183E

STEERING COLUMN

PFP:48810

EGS0014X

STEERING COLUMN

Removal and Installation COMPONENT

SEC. 481•488

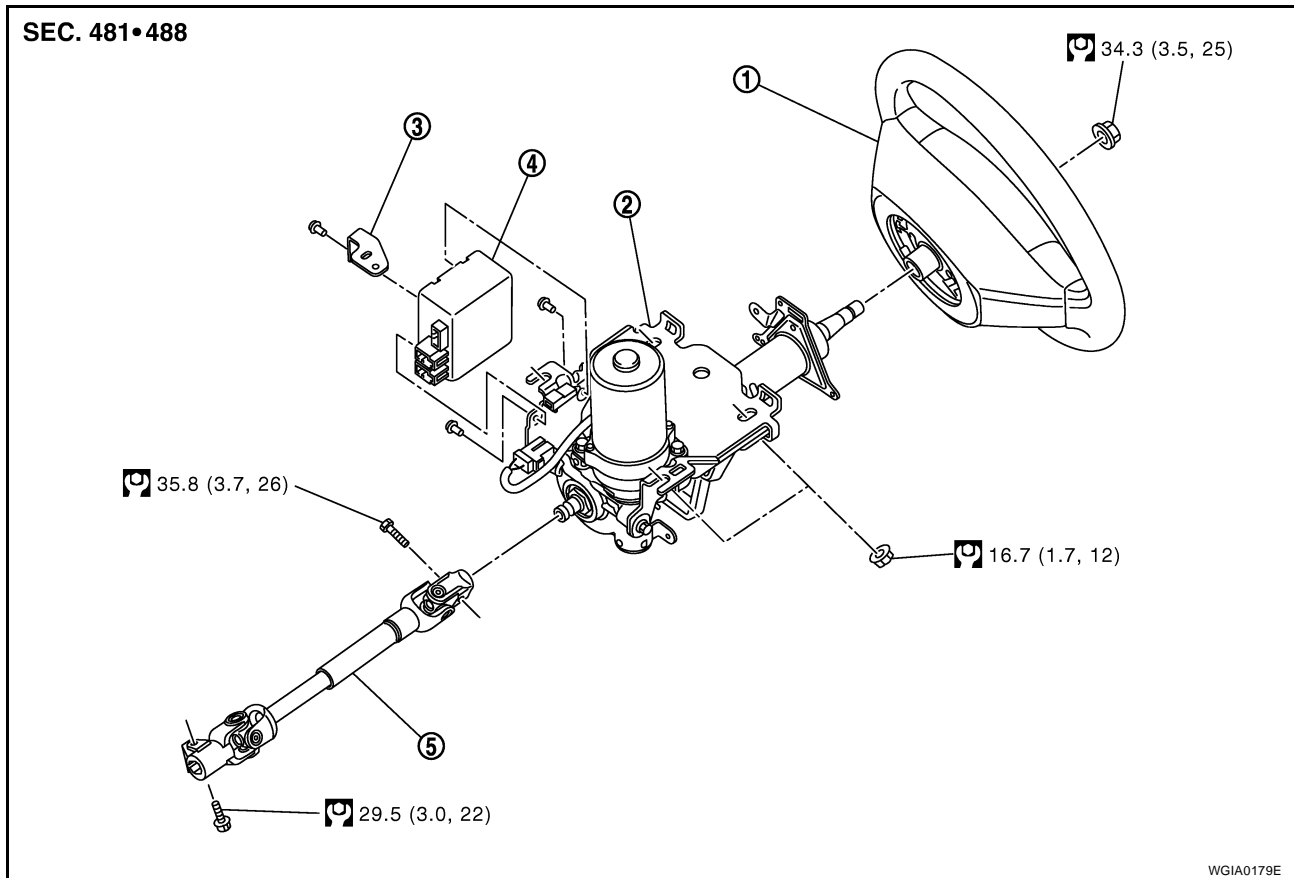

- | | | |
|---------------------|--|------------|
| 1. Steering wheel | 2. Steering column assembly (with motor, reduction gear, sensor) | 3. Bracket |
| 4. EPS control unit | 5. Intermediate shaft | |

CAUTION:

- Do not allow axial impact to steering column assembly during removal and installation.
- Steering column must be kept at maximum tilt up position during removal and installation. Do not operate tilt mechanism while steering column is out of the vehicle.
- Put matching mark on intermediate shaft and steering column assembly before removing intermediate shaft.
- When steering wheel is turned repeatedly with the vehicle stopped, care must be taken because motor and EPS control unit may get too hot.
- Steering column assembly is heavy. Care must be taken when removing steering column assembly from vehicle.
- Do not put steering column assembly near the things that generate excessive magnetic force.
- Steering column assembly (with motor, reduction gear, sensor) cannot be disassembled.

REMOVAL

1. Set vehicle to the straight ahead-position.
2. Remove driver air bag module. Refer to [SRS-41, "DRIVER AIR BAG MODULE"](#) .
3. Remove steering wheel. Refer to [PS-8, "Removal and Installation"](#) .
4. Remove steering column cover (upper and lower). Refer to [IP-10, "Component Parts"](#) .
5. Remove combination switch & spiral cable. Refer to [SRS-44, "SPIRAL CABLE"](#) .
6. Remove instrument lower finisher. Refer to [IP-10, "Component Parts"](#) .
7. Disconnect each switch connector installed to steering column assembly, and then disconnect harness from steering column assembly.

STEERING COLUMN

8. Remove bolt of intermediate shaft (upper side), and then remove intermediate shaft from steering column assembly.
9. Remove steering column assembly mounting nuts, and then remove steering column assembly from vehicle.
10. Remove bolt of intermediate shaft (lower side), and then remove intermediate shaft from vehicle.
11. Remove screws of bracket and EPS control unit, and then remove bracket and EPS control unit from steering column assembly.

INSPECTION AFTER REMOVAL

- Check each part of steering column assembly, EPS control unit and intermediate shaft for damage and replace as necessary.
- Measure the length "L" as shown, if vehicle has been involved in a minor collision. Replace steering column assembly (with motor, reduction gear, sensor) if outside the standard.

Steering column length "L"	Minimum	462.1 mm (18.19 in)
	Nominal	464.1 mm (18.27 in)
	Maximum	466.1 mm (18.35 in)

- Check tilt mechanism for damage or other malfunctions. Replace steering column assembly (with motor, reduction gear, sensor) as necessary.
- Measure steering column assembly rotating torque using Tool. Replace steering column assembly (with motor, reduction gear, sensor) if outside the standard.

Tool number : ST3127S000 (J-25742-1)

Rotating torque : 0 - 2.1 N·m (0 - 0.21 kg·m, 0 - 18 in·lb)

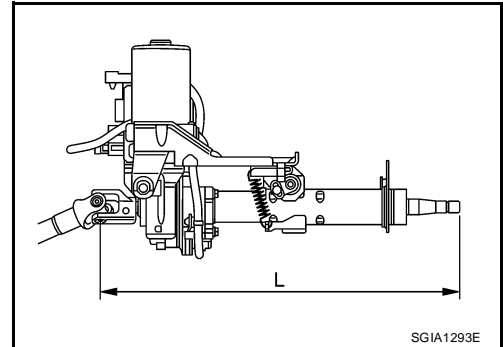

INSTALLATION

Installation is in the reverse order of removal.

- Installation is in the reverse order of removal. For tightening torque, refer to [PS-9, "COMPONENT"](#).
- When tightening bolt (intermediate shaft lower side), tighten it by hand first, and make sure there is no feeling of sticking or galling before final tightening.

CAUTION:

Insert bolt in the proper direction. (Do not insert it from the other side.)

- When connecting intermediate shaft upper side (1) and column shaft, make sure the bolt is securely seated in groove (A) of column shaft (A) before final tightening.

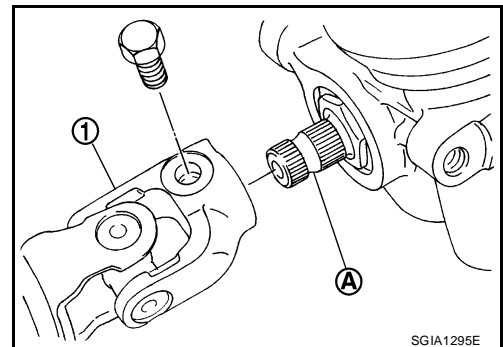

INSPECTION AFTER INSTALLATION

- Rotate steering wheel to check for decentered condition, binding, noise or excessive steering effort.
- After installing steering column assembly, perform self-diagnosis with CONSULT-II to ensure correct operation. Refer to [STC-13, "CONSULT-II Function \(EPS\)"](#).

STEERING COLUMN

- Check tilt mechanism operating range “L” as shown.

Tilt operating range “L” : 20 mm (0.79 in)

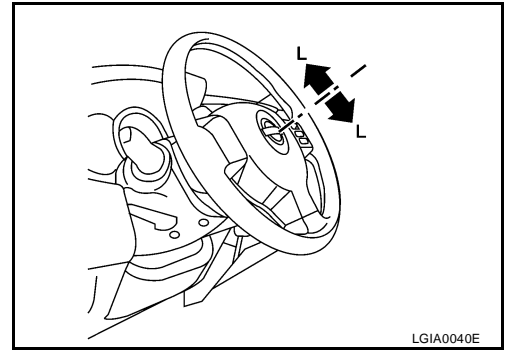

A

B

C

D

E

F

PS

H

I

J

K

L

M

POWER STEERING GEAR

POWER STEERING GEAR

PF:49001

Removal and Installation COMPONENT

EGS0014Y

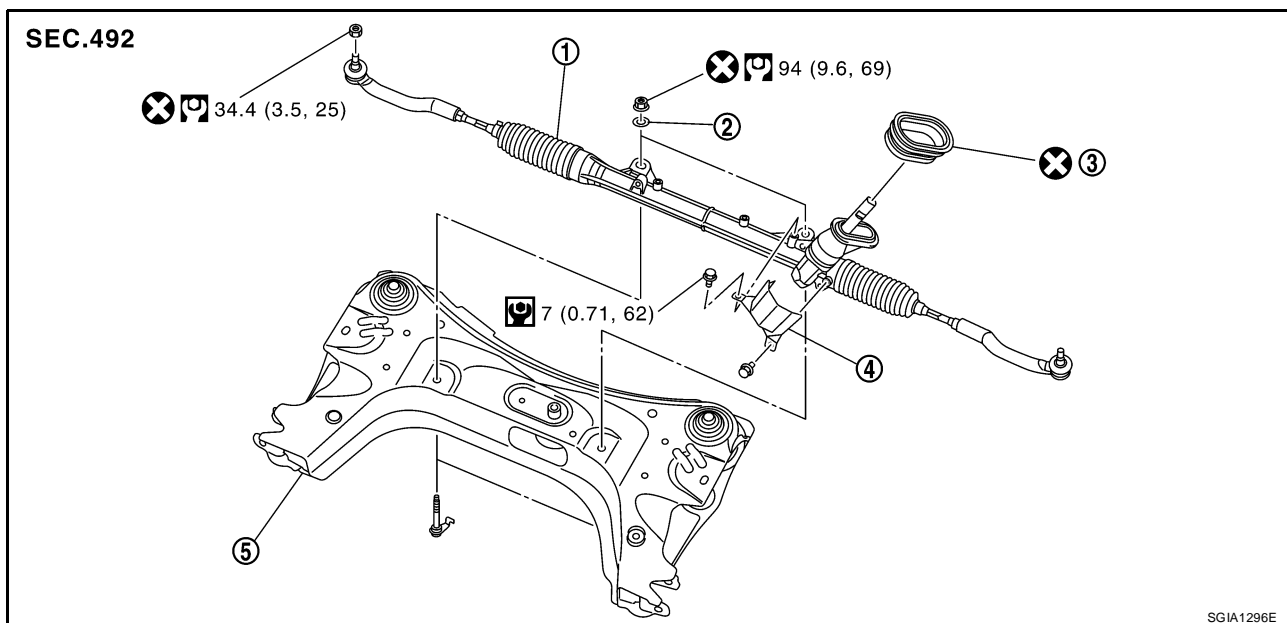

- | | | |
|---------------------------|----------------------------|-------------------|
| 1. Steering gear assembly | 2. Washer | 3. Fire wall seal |
| 4. Heat insulator | 5. Front suspension member | |

Refer to [GI-8, "HOW TO USE THIS MANUAL"](#) for the symbols.

CAUTION:

Spiral cable may be cut if steering wheel turns while separating steering column assembly and steering gear assembly. Be sure to secure steering wheel using string to avoid turning.

REMOVAL

1. Set vehicle to the straight-ahead position.
2. Remove bolt of intermediate shaft (lower side), and then remove intermediate shaft from steering gear pinion shaft.
3. Raise vehicle.
4. Remove tires from vehicle with a power tool.
5. Loosen steering outer socket (1) mounting nut.
6. Remove steering outer socket (1) from steering knuckle (2) so as not to damage ball joint boot (3) using the ball joint remover (suitable tool).

CAUTION:

Temporarily tighten the nut to prevent damage to threads and to prevent the ball joint remover (suitable tool) from suddenly coming off.

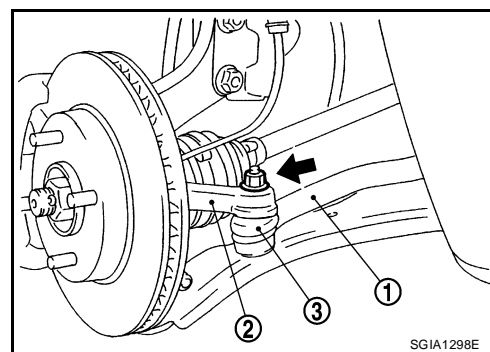

7. Remove front suspension member. Refer to [FSU-10, "Removal and Installation"](#).
8. Remove mounting bolts and nuts of steering gear assembly.

INSTALLATION

Installation is in the reverse order of removal.

- For tightening torque, refer to [PS-12, "COMPONENT"](#).
- Clean mounting surface on the body side of fire wall seal when installing steering gear assembly.

POWER STEERING GEAR

- Check wheel alignment under unladen conditions with tires on level ground. Refer to [FSU-6, "Wheel Alignment Inspection"](#).

INSPECTION AFTER INSTALLATION

Rotate steering wheel to check for decentered condition, binding, noise or excessive steering effort.

Disassembly and Assembly COMPONENT (R24K TYPE)

EGS0014Z

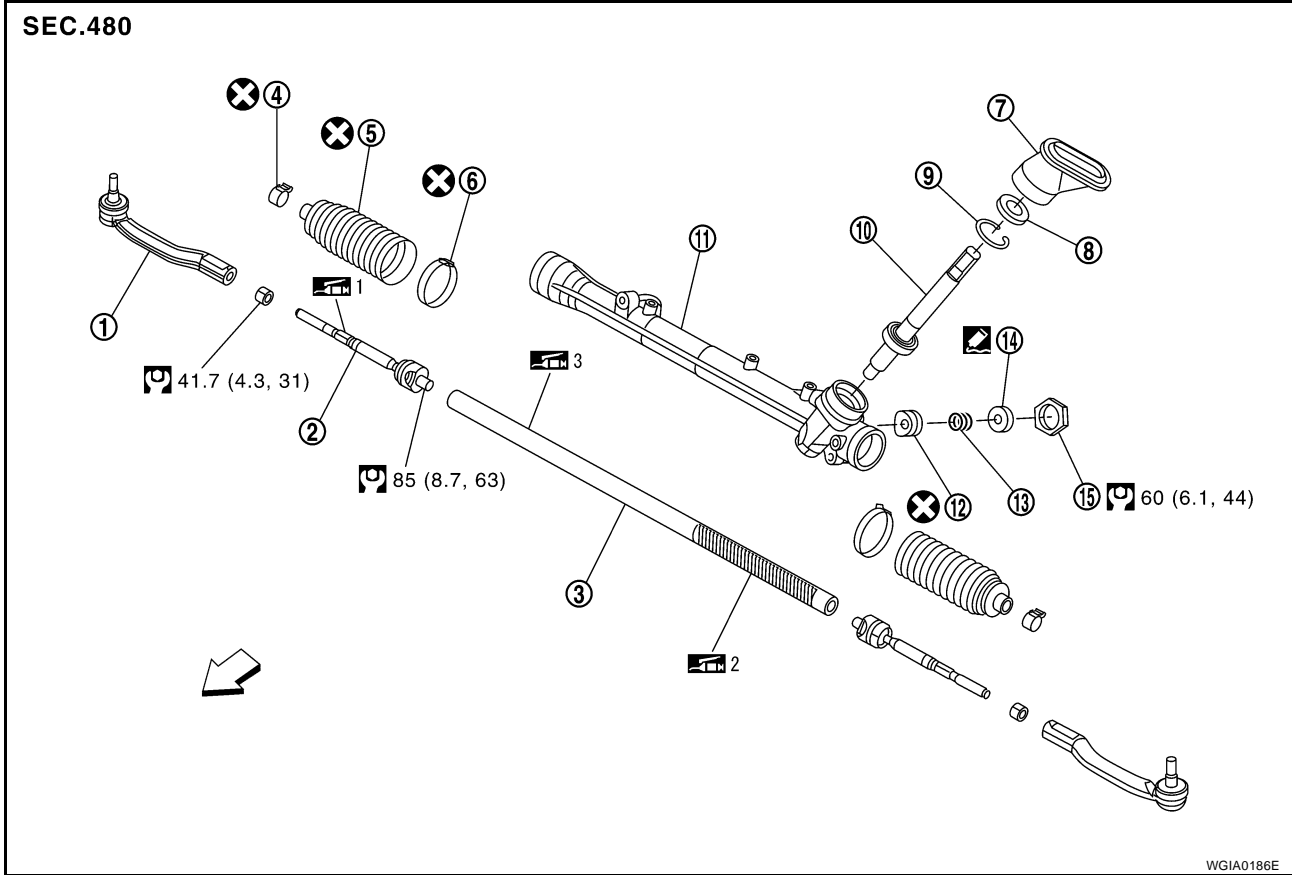

- | | | |
|--------------------------------|---------------------------|--------------------------------|
| 1. Outer socket | 2. Inner socket | 3. Rack assembly |
| 4. Boot clamp (small diameter) | 5. Boot | 6. Boot clamp (large diameter) |
| 7. Joint cover | 8. Pinion seal | 9. Snap ring |
| 10. Pinion assembly | 11. Gear housing assembly | 12. Retainer |
| 13. Spring | 14. Adjusting screw | 15. Lock nut |

← : Front

Refer to [GI-8, "HOW TO USE THIS MANUAL"](#) for the symbols unless shown below.

Apply Genuine Thread Locking Sealant, Three Bound 1141 or equivalent.

:1 Apply Genuine Lithium Soap, Idemitsu Autorex A or equivalent.

:2 Apply Genuine Lithium Soap, Wanlouver MO No.2 (manufactured by Kyoudouyushi) or equivalent.

:3 Apply Genuine Lithium Soap, Multemp AC-P (manufactured by Kyoudouyushi) or equivalent.

CAUTION:

Clean steering gear assembly with kerosene before disassembling.

DISASSEMBLY

1. Loosen outer socket lock nut, and then remove outer socket from inner socket.
2. Remove boot clamp, and then remove boot from inner socket.

CAUTION:

Do not damage inner socket and gear housing assembly when removing boot. Inner socket and gear housing assembly must be replaced if inner socket and gear housing assembly are damaged because it may allow foreign material to enter.

POWER STEERING GEAR

3. Remove inner socket from rack assembly while holding the flat portion of the rack next to the inner socket using a suitable tool.
4. Measure adjusting screw height "H", and loosen lock nut (2).
5. Remove adjusting screw (1), retainer (3) and spring (4) from gear housing assembly (5).

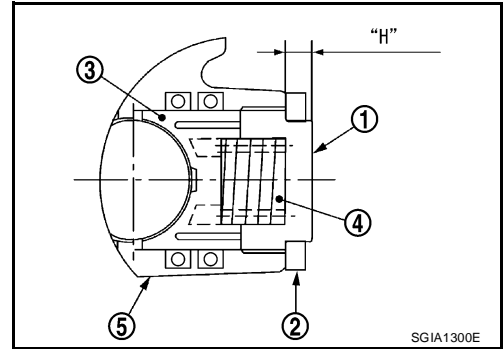

INSPECTION AFTER DISASSEMBLY

Joint Cover

Check joint cover protrusion for damage. Replace if there are.

Rack and Pinion Assembly

- Check pinion assembly for damage or wear. Replace as necessary.
- Rotate pinion assembly and check for torque variation or rattle. Replace steering gear as necessary.

Gear Housing Assembly

Check gear housing assembly for damage or scratches. Replace steering gear as necessary.

Outer Socket and Inner Socket

1. Check ball joint swinging torque.
 - Hook a spring balance at the point shown and pull the spring balance. Make sure that the spring balance reads the specified value when ball stud and inner socket start to move. Replace outer socket and inner socket if they are outside the standard.

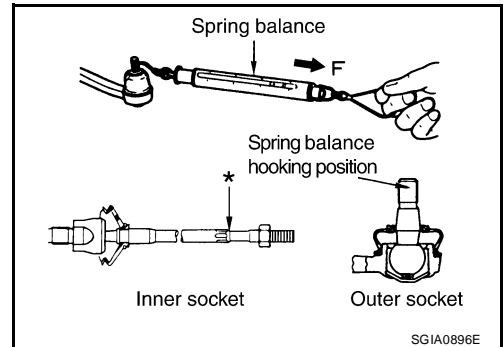

Items	Outer socket	Inner socket
Measuring point of spring balance	Ball stud upper side	Measuring point at * mark shown in the figure
Swinging torque	0.3 - 2.9 N·m (0.03 - 0.29 kg-m, 3.0 - 25 in-lb)	0.5 - 5.0 N·m (0.06 - 0.51 kg-m, 5 - 44 in-lb)
Spring balance measurement	6.0 - 58 N (0.61 - 5.91 kg-f, 1.35 - 13.03 lb-f)	4.3 - 43.5 N (0.44 - 4.44 kg-f, 0.97 - 9.79 lb-f)

2. Ball joint axial end play

POWER STEERING GEAR

- Apply an axial load of 490 N (50 kg-f, 111 lb-f) to ball stud using a dial gauge. Measure amount of stud movement, and then make sure that the value is within the specified range. Replace outer socket and inner socket if the measured value is outside the standard.

Outer socket	0.5 mm (0.020 in) or less
Inner socket	0.2 mm (0.008 in) or less

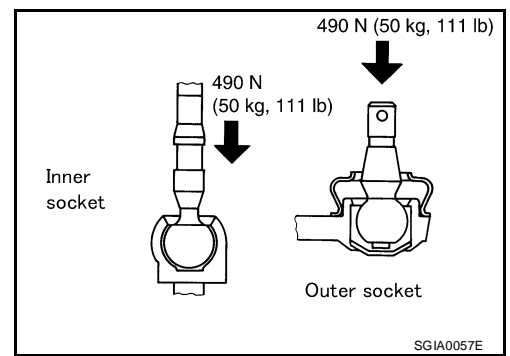

ASSEMBLY

1. Apply recommended grease to teeth part and bush part of rack assembly, if necessary.
2. Apply recommended grease to back of rack assembly, if necessary.
3. Install inner socket to rack assembly. Torque to specified value while holding the flat portion of the rack next to the inner socket using a suitable tool.
4. Apply recommended grease to inner socket. For application points, refer to [PS-13, "COMPONENT \(R24K TYPE\)"](#).
5. Decide on the neutral position for the rack assembly.

Rack stroke "L" : 65.0 mm (2.559 in)

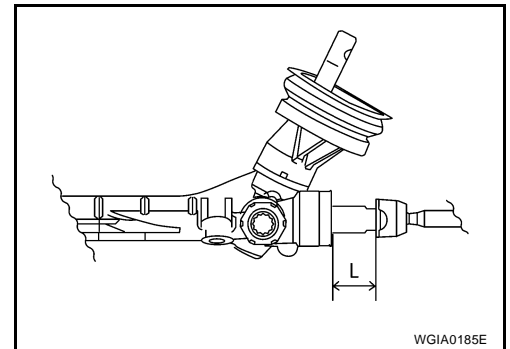

6. Apply recommended grease to around retainer (3), then install retainer (3), spring (4) and adjusting screw (1) to gear housing assembly (5).
7. Apply recommended thread locking sealant to the thread (2 turns thread), and then screw in the adjusting screw (1) until it reaches height "H" from gear housing assembly (5) measured before disassembling.
8. Tighten lock nut to (2) the specified torque securing it to prevent adjusting screw (1) from freewheeling condition.
9. Move rack assembly 10 strokes throughout the full stroke so that the parts can fit with each other.

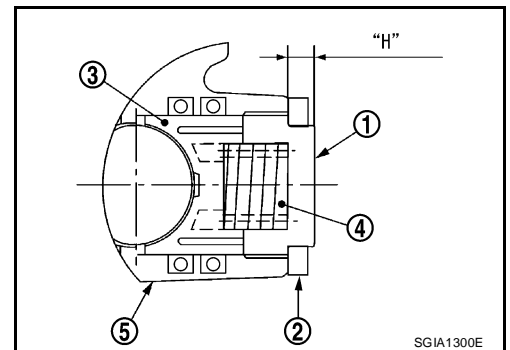

10. Using Tools A and B, measure rotating torque of pinion assembly. If the measurement is outside of the specified range, readjust pinion rotating torque. If the measurement is outside of the specified range for readjust, replace steering gear assembly.

Tool numbers A: ST3127S000 (J-25742-1)

B: KV48103400 (—)

Pinion rotating torque standard	
Around neutral position (within ±100°) Average A	0.3 - 1.5 N·m (0.03 - 0.15 kg·m, 3 - 13 in·lb)
Maximum variation C	1.86 N·m (0.19 kg·m, 16 in·lb)

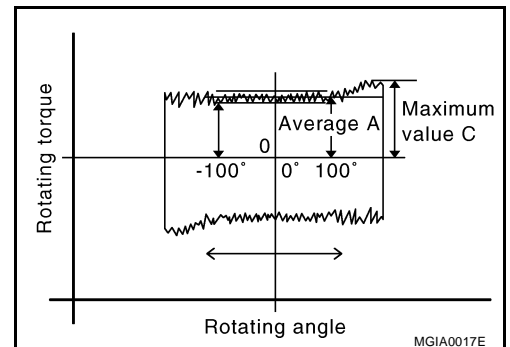

POWER STEERING GEAR

11. Set dial gauge to the back of rack assembly on the pinion assembly side around the center of stroke. Measure displacement of rack under torsional torque of $\pm 7.8 \text{ N}\cdot\text{m}$ ($0.80 \text{ kg}\cdot\text{m}$, $69 \text{ in}\cdot\text{lb}$), and then check if it is within the standard value. If the measurement is outside the standard value, adjust it again. After the readjustment, if measurement is still outside the standard value, replace steering gear assembly.

Standard value : Less than **0.1 mm (0.004 in)**

12. Install boot to gear housing assembly and inner socket.

13. Install boot clamp (1) to boot using Tool.

NOTE:

Install large diameter side boot clamp (1) securely to boot groove, and crimp it so as to have clearance of 3 mm (0.12 in) or less as shown.

Tool number : KV40107300 (—)

14. Install joint cover (1) to gear housing assembly (2).

CAUTION:

Install joint cover so that the protrusion for locating is securely set to gear housing groove.

15. Adjust inner socket to standard length "L", and then tighten lock nut to the specified torque. Refer to [PS-13, "COMPONENT \(R24K TYPE\)"](#) . Check length of inner socket "L" again after tightening lock nut. Make sure that the length is the standard.

Inner socket length "L" : **57.8 mm (2.276 in)**

CAUTION:

Adjust toe-in. Refer to [FSU-8, "TOE-IN INSPECTION"](#) . Length achieved after toe-in adjustment is not necessarily the above value.

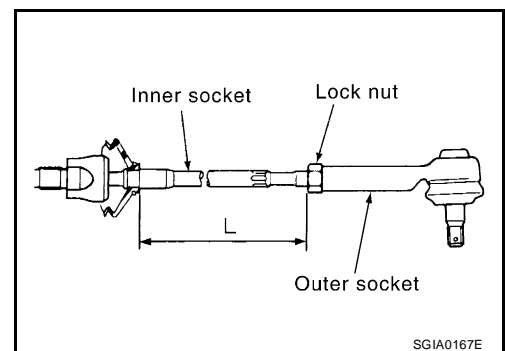
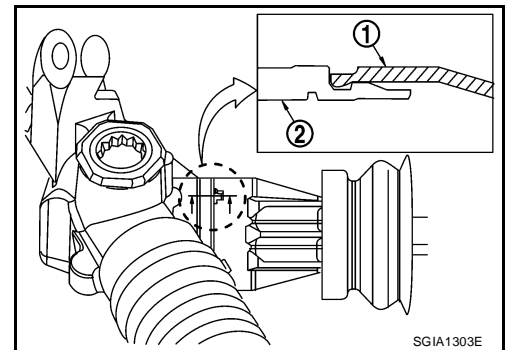
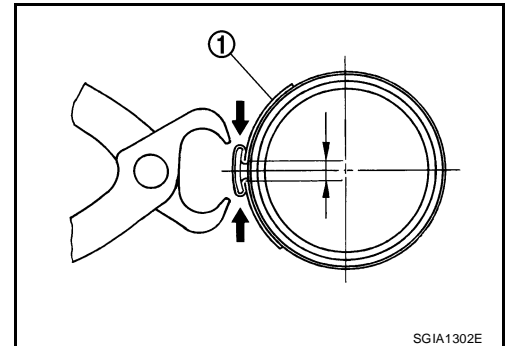
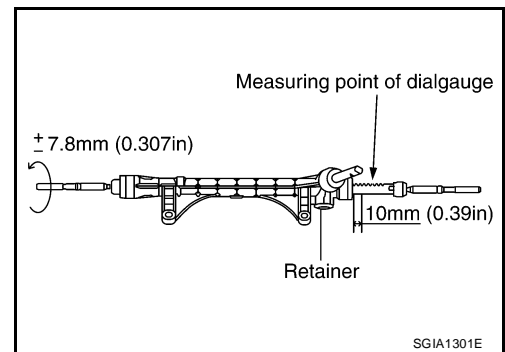

SERVICE DATA AND SPECIFICATIONS (SDS)

SERVICE DATA AND SPECIFICATIONS (SDS)

PFP:00030

Steering Wheel

EGS00150

Steering wheel axial end play	0 mm (0 in)
Steering wheel play	0 - 35 mm (0 - 1.38 in)
Steering wheel turning force	Less than 36 N (3.7 kg-f, 8.2 lb-f)

Steering Angle

EGS00151

Inner wheel Degree minute (Decimal degree)	Minimum	35° 00' (35.0°)
	Nominal	38° 00' (38.0°)
	Maximum	39° 00' (39.0°)
Outer wheel Degree minute (Decimal degree)		33° 00' (33.0°)

Steering Column

EGS00152

Steering column length "L"	Minimum	462.1 mm (18.19 in)
	Nominal	464.1 mm (18.27 in)
	Maximum	466.1 mm (18.35 in)

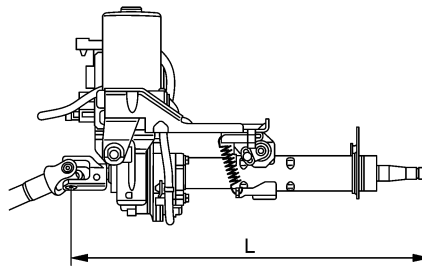

SGIA1293E

Steering column assembly rotating torque	0 - 2.1 N·m (0 - 0.21 kg-m, 0 - 18 in-lb)
Tilt operating range	20 mm (0.79 in)

Steering Outer Socket and Inner Socket

EGS00153

Steering gear type	R24K	
Outer socket ball stud	Swinging torque	0.3 - 2.9 N·m (0.03 - 0.29 kg-m, 3.0 - 25 in-lb)
	Measurement on spring balance Measuring point: ball stud upper side	6.0 - 58 N (0.61 - 5.91 kg-f, 1.35 - 13.03 lb-f)
	Axial end play	0.5 mm (0.020 in) or less
Inner socket ball joint	Swinging torque	0.5 - 5.0 N·m (0.06 - 0.51 kg-m, 5 - 44 in-lb)
	● Measurement on spring balance ● Measuring point at *mark shown	4.3 - 43.5 N (0.44 - 4.44 kg-f, 0.97 - 9.79 lb-f)
	Axial end play	0.2 mm (0.008 in) or less
Inner socket length "L"	57.8 mm (2.276 in)	

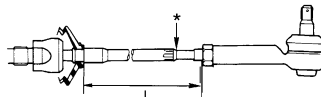

SGIA0950E

SERVICE DATA AND SPECIFICATIONS (SDS)

Steering Gear

EGS00154

Steering gear model	R24K
Rack neutral position, dimension "L" (rack stroke)	65.0 mm (2.559 in)

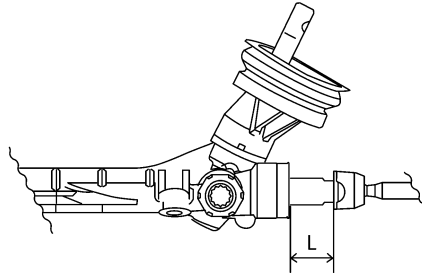

WGIA0185E

Pinion rotating torque standard	Around neutral position (within $\pm 100^\circ$) Average A	0.3 - 1.5 N·m (0.03 - 0.15 kg-m, 3 - 13 in-lb)
	Maximum variation C	1.86 N·m (0.19 kg-m, 16 in-lb)

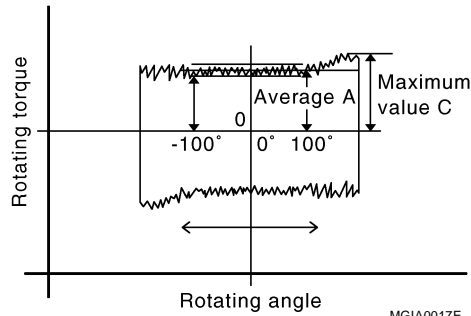

MGIA0017E