

**SECTION IP**  
**INSTRUMENT PANEL**

A  
B  
C  
D  
E  
F  
G  
H  
IP  
J  
K  
L  
M

**CONTENTS**

<b>PRECAUTIONS</b> .....	<b>2</b>	TRUNK .....	7
Precautions for Supplemental Restraint System (SRS) "AIR BAG" and "SEAT BELT PRE-TENSIONER" .....	2	SUNROOF/HEADLINING .....	7
Precautions .....	2	OVERHEAD CONSOLE (FRONT AND REAR).....	7
<b>PREPARATION</b> .....	<b>3</b>	SEATS .....	7
Special Service Tools .....	3	UNDERHOOD .....	7
Commercial Service Tools .....	3	Diagnostic Worksheet .....	8
<b>SQUEAK AND RATTLE TROUBLE DIAGNOSES</b> .....	<b>4</b>	<b>INSTRUMENT PANEL ASSEMBLY</b> .....	<b>10</b>
Work Flow .....	4	Component Parts .....	10
CUSTOMER INTERVIEW .....	4	Removal and Installation .....	11
DUPLICATE THE NOISE AND TEST DRIVE .....	5	WORK STEPS .....	11
CHECK RELATED SERVICE BULLETINS .....	5	INSTRUMENT PANEL ASSEMBLY .....	12
LOCATE THE NOISE AND IDENTIFY THE ROOT CAUSE .....	5	CLUSTER LID A .....	16
REPAIR THE CAUSE .....	5	CLUSTER LID C .....	18
CONFIRM THE REPAIR .....	6	COMBINATION METER .....	19
Generic Squeak and Rattle Troubleshooting .....	6	GLOVE BOX ASSEMBLY .....	21
INSTRUMENT PANEL .....	6	INSTRUMENT LOWER FINISHER .....	21
CENTER CONSOLE .....	6	CENTER CONSOLE ASSEMBLY .....	22
DOORS .....	6	Disassembly and Assembly .....	24
		GLOVE BOX ASSEMBLY .....	24
		CENTER CONSOLE ASSEMBLY .....	25
		COMBINATION METER .....	25

# PRECAUTIONS

## PRECAUTIONS

PF0:00001

### Precautions for Supplemental Restraint System (SRS) “AIR BAG” and “SEAT BELT PRE-TENSIONER”

EIS009AU

The Supplemental Restraint System such as “AIR BAG” and “SEAT BELT PRE-TENSIONER”, used along with a front seat belt, helps to reduce the risk or severity of injury to the driver and front passenger for certain types of collision. This system includes seat belt switch inputs and dual stage front air bag modules. The SRS system uses the seat belt switches to determine the front air bag deployment, and may only deploy one front air bag, depending on the severity of a collision and whether the front occupants are belted or unbelted. Information necessary to service the system safely is included in the SRS and SB section of this Service Manual.

#### **WARNING:**

- To avoid rendering the SRS inoperative, which could increase the risk of personal injury or death in the event of a collision which would result in air bag inflation, all maintenance must be performed by an authorized NISSAN/INFINITI dealer.
- Improper maintenance, including incorrect removal and installation of the SRS, can lead to personal injury caused by unintentional activation of the system. For removal of Spiral Cable and Air Bag Module, see the SRS section.
- Do not use electrical test equipment on any circuit related to the SRS unless instructed to in this Service Manual. SRS wiring harnesses can be identified by yellow and/or orange harnesses or harness connectors.

## Precautions

EIS00972

- Disconnect both battery terminals in advance.
- Disconnect air bag system line in advance.
- Never tamper with or force air bag lid open, as this may adversely affect air bag performance.
- Be careful not to scratch pad and other parts.
- When removing or disassembling any part, be careful not to damage or deform it. Protect parts which may get in the way with cloth.
- When removing parts, protect parts by wrapping tools with vinyl or tape.
- Keep removed parts protected with cloth.
- If a clip is deformed or damaged, replace it.
- If a non-reusable part is removed, replace it with a new one.
- Tighten bolts and nuts firmly to the specified torque.
- After re-assembly has been completed, make sure each part functions correctly.
- Remove stains in the following way.

Water-soluble stains:

Dip a soft cloth in warm water, and then squeeze it tightly. After wiping the stain, wipe with a soft dry cloth.

Oil stain:

Dissolve a synthetic detergent in warm water (density of 2 to 3% or less), dip the cloth, then clean off the stain with the cloth. Next, dip the cloth in fresh water and squeeze it tightly. Then clean off the detergent completely. Then wipe the area with a soft dry cloth.

- Do not use any organic solvent, such as thinner or benzine.

# PREPARATION

## PREPARATION

PFP:00002

### Special Service Tools

EIS00973

The actual shapes of Kent-Moore tools may differ from those of special service tools illustrated here.

Tool number (Kent-Moore No.) Tool name	Description
— (J-39570) Chassis ear	Locating the noise
— (J-43980) NISSAN Squeak and Rattle Kit	Repairing the cause of noise

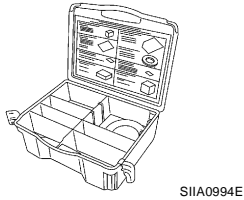
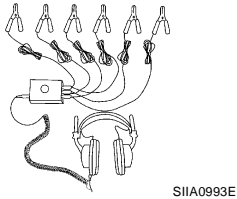

### Commercial Service Tools

EIS00974

Tool name	Description
Engine ear	Locating the noise
Power tool	Loosening bolts and nuts

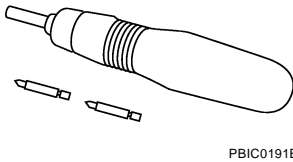
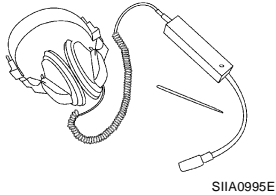

A  
B  
C  
D  
E  
F  
G  
H  
IP  
J  
K  
L  
M

# SQUEAK AND RATTLE TROUBLE DIAGNOSES

## SQUEAK AND RATTLE TROUBLE DIAGNOSES

PF0:0000

### Work Flow

EIS009AV

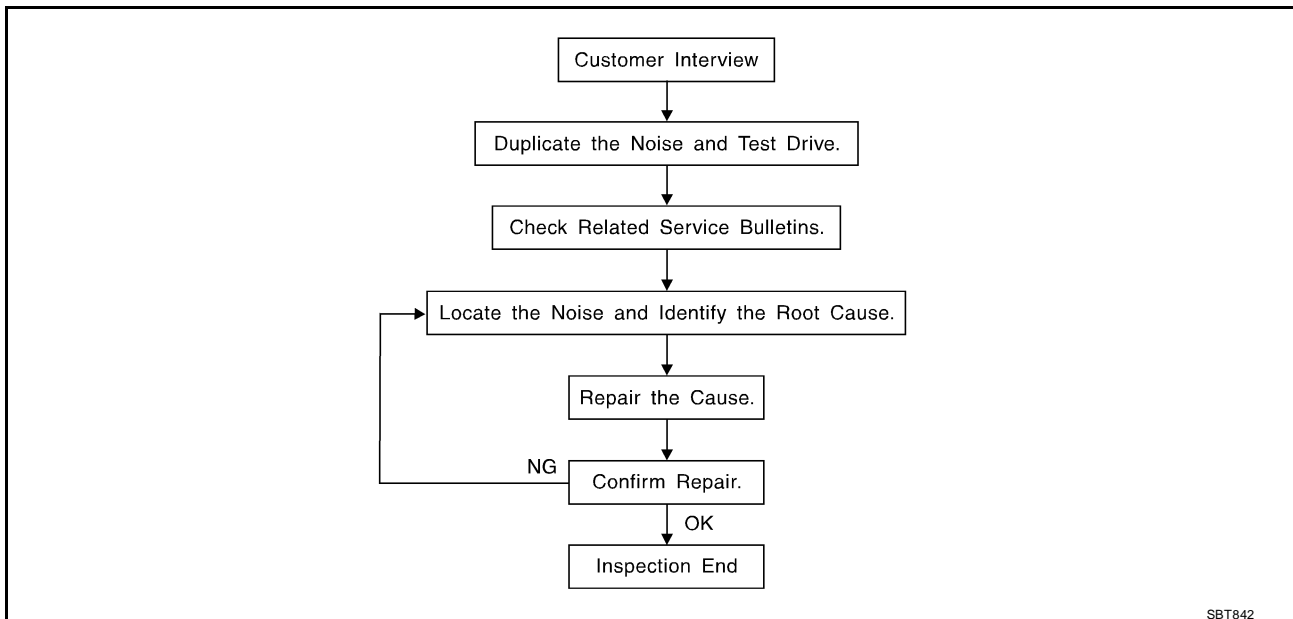

### CUSTOMER INTERVIEW

Interview the customer, if possible, to determine the conditions that exist when the noise occurs. Use the Diagnostic Worksheet during the interview to document the facts and conditions when the noise occurs and any customer's comments; refer to [IP-8, "Diagnostic Worksheet"](#). This information is necessary to duplicate the conditions that exist when the noise occurs.

- The customer may not be able to provide a detailed description or the location of the noise. Attempt to obtain all the facts and conditions that exist when the noise occurs (or does not occur).
- If there is more than one noise in the vehicle, be sure to diagnose and repair the noise that the customer is concerned about. This can be accomplished by test driving the vehicle with the customer.
- After identifying the type of noise, isolate the noise in terms of its characteristics. The noise characteristics are provided so the customer, service adviser and technician are all speaking the same language when defining the noise.
- Squeak — (Like tennis shoes on a clean floor)  
Squeak characteristics include the light contact/fast movement/brought on by road conditions/hard surfaces = higher pitch noise/softer surfaces = lower pitch noises/edge to surface = chirping.
- Creak — (Like walking on an old wooden floor)  
Creak characteristics include firm contact/slow movement/twisting with a rotational movement/pitch dependent on materials/often brought on by activity.
- Rattle — (Like shaking a baby rattle)  
Rattle characteristics include the fast repeated contact/vibration or similar movement/loose parts/missing clip or fastener/incorrect clearance.
- Knock — (Like a knock on a door)  
Knock characteristics include hollow sounding/sometimes repeating/often brought on by driver action.
- Tick — (Like a clock second hand)  
Tick characteristics include gentle contacting of light materials/loose components/can be caused by driver action or road conditions.
- Thump — (Heavy, muffled knock noise)  
Thump characteristics include softer knock/dead sound often brought on by activity.
- Buzz — (Like a bumblebee)  
Buzz characteristics include high frequency rattle/firm contact.
- Often the degree of acceptable noise level will vary depending upon the person. A noise that you may judge as acceptable may be very irritating to the customer.
- Weather conditions, especially humidity and temperature, may have a great effect on noise level.

# SQUEAK AND RATTLE TROUBLE DIAGNOSES

## DUPLICATE THE NOISE AND TEST DRIVE

If possible, drive the vehicle with the customer until the noise is duplicated. Note any additional information on the Diagnostic Worksheet regarding the conditions or location of the noise. This information can be used to duplicate the same conditions when you confirm the repair.

If the noise can be duplicated easily during the test drive, to help identify the source of the noise, try to duplicate the noise with the vehicle stopped by doing one or all of the following:

1. Close a door.
  2. Tap or push/pull around the area where the noise appears to be coming from.
  3. Rev the engine.
  4. Use a floor jack to recreate vehicle "twist".
  5. At idle, apply engine load (electrical load, half-clutch on M/T model, drive position on A/T model).
  6. Raise the vehicle on a hoist and hit a tire with a rubber hammer.
- Drive the vehicle and attempt to duplicate the conditions the customer states exist when the noise occurs.
  - If it is difficult to duplicate the noise, drive the vehicle slowly on an undulating or rough road to stress the vehicle body.

## CHECK RELATED SERVICE BULLETINS

After verifying the customer concern or symptom, check ASIST for Technical Service Bulletins (TSBs) related to that concern or symptom.

If a TSB relates to the symptom, follow the procedure to repair the noise.

## LOCATE THE NOISE AND IDENTIFY THE ROOT CAUSE

1. Narrow down the noise to a general area. To help pinpoint the source of the noise, use a listening tool (Chassis Ear: J-39570, Engine Ear: J-39565, and mechanics stethoscope).
2. Narrow down the noise to a more specific area and identify the cause of the noise by:
  - Removing the components in the area that you suspect the noise is coming from.  
**Do not use too much force when removing clips and fasteners, otherwise clips and fasteners can be broken or lost during the repair, resulting in the creation of new noise.**
  - Tapping or pushing/pulling the component that you suspect is causing the noise.  
**Do not tap or push/pull the component with excessive force, otherwise the noise will be eliminated only temporarily.**
  - Feeling for a vibration with your hand by touching the component(s) that you suspect is (are) causing the noise.
  - Placing a piece of paper between components that you suspect are causing the noise.
  - Looking for loose components and contact marks.

Refer to [IP-6, "Generic Squeak and Rattle Troubleshooting"](#) .

## REPAIR THE CAUSE

- If the cause is a loose component, tighten the component securely.
- If the cause is insufficient clearance between components:
  - Separate components by repositioning or loosening and retightening the component, if possible.
  - Insulate components with a suitable insulator such as urethane pads, foam blocks, felt cloth tape or urethane tape. A NISSAN Squeak and Rattle Kit (J-43980) is available through your authorized NISSAN Parts Department.

### CAUTION:

**Do not use excessive force as many components are constructed of plastic and may be damaged. Always check with the Parts Department for the latest parts information.**

The following materials are contained in the NISSAN Squeak and Rattle Kit (J-43980). Each item can be ordered separately as needed.

URETHANE PADS [1.5 mm (0.059 in) thick]

Insulates connectors, harness, etc.

76268-9E005: 100 x 135 mm (3.94 x 5.31 in)/76884-71L01: 60 x 85 mm (2.36 x 3.35 in)/76884-71L02: 15 x 25 mm (0.59 x 0.98 in)

INSULATOR (Foam blocks)

Insulates components from contact. Can be used to fill space behind a panel.

# SQUEAK AND RATTLE TROUBLE DIAGNOSES

73982-9E000: 45 mm (1.77 in) thick, 50 x 50 mm (1.97 x 1.97 in)/73982-50Y00: 10 mm (0.39 in) thick, 50 x 50 mm (1.97 x 1.97 in)

INSULATOR (Light foam block)

80845-71L00: 30 mm (1.18 in) thick, 30 x 50 mm (1.18 x 1.97 in)

FELT CLOTH TAPE

Used to insulate where movement does not occur. Ideal for instrument panel applications.

68370-4B000: 15 x 25 mm (0.59 x 0.98 in) pad/68239-13E00: 5 mm (0.20 in) wide tape roll

The following materials, not found in the kit, can also be used to repair squeaks and rattles.

UHMW (TEFLON) TAPE

Insulates where slight movement is present. Ideal for instrument panel applications.

SILICONE GREASE

Used in place of UHMW tape that will be visible or not fit.

Note: Will only last a few months.

SILICONE SPRAY

Use when grease cannot be applied.

DUCT TAPE

Use to eliminate movement.

## CONFIRM THE REPAIR

Confirm that the cause of a noise is repaired by test driving the vehicle. Operate the vehicle under the same conditions as when the noise originally occurred. Refer to the notes on the Diagnostic Worksheet.

## Generic Squeak and Rattle Troubleshooting

EIS009AW

Refer to Table of Contents for specific component removal and installation information.

## INSTRUMENT PANEL

Most incidents are caused by contact and movement between:

1. The cluster lid A and instrument panel
2. Acrylic lens and combination meter housing
3. Instrument panel to front pillar garnish
4. Instrument panel to windshield
5. Instrument panel mounting pins
6. Wiring harnesses behind the combination meter
7. A/C defroster duct and duct joint

These incidents can usually be located by tapping or moving the components to duplicate the noise or by pressing on the components while driving to stop the noise. Most of these incidents can be repaired by applying felt cloth tape or silicone spray (in hard to reach areas). Urethane pads can be used to insulate wiring harness.

### CAUTION:

**Do not use silicone spray to isolate a squeak or rattle. If you saturate the area with silicone, you will not be able to recheck the repair.**

## CENTER CONSOLE

Components to pay attention to include:

1. Shifter assembly cover to finisher
2. A/C control unit and cluster lid C
3. Wiring harnesses behind audio and A/C control unit

The instrument panel repair and isolation procedures also apply to the center console.

## DOORS

Pay attention to the:

1. Finisher and inner panel making a slapping noise
2. Inside handle escutcheon to door finisher
3. Wiring harnesses tapping
4. Door striker out of alignment causing a popping noise on starts and stops

# SQUEAK AND RATTLE TROUBLE DIAGNOSES

Tapping or moving the components or pressing on them while driving to duplicate the conditions can isolate many of these incidents. You can usually insulate the areas with felt cloth tape or insulator foam blocks from the NISSAN Squeak and Rattle Kit (J-43980) to repair the noise.

A

## TRUNK

Trunk noises are often caused by a loose jack or loose items put into the trunk by the owner.

B

In addition look for:

1. Trunk lid bumpers out of adjustment
2. Trunk lid striker out of adjustment
3. The trunk lid torsion bars knocking together
4. A loose license plate or bracket

C

Most of these incidents can be repaired by adjusting, securing or insulating the item(s) or component(s) causing the noise.

D

## SUNROOF/HEADLINING

Noises in the sunroof/headlining area can often be traced to one of the following:

1. Sunroof lid, rail, linkage or seals making a rattle or light knocking noise
2. Sun visor shaft shaking in the holder
3. Front or rear windshield touching headliner and squeaking

E

Again, pressing on the components to stop the noise while duplicating the conditions can isolate most of these incidents. Repairs usually consist of insulating with felt cloth tape.

F

G

## OVERHEAD CONSOLE (FRONT AND REAR)

Overhead console noises are often caused by the console panel clips not being engaged correctly. Most of these incidents are repaired by pushing up on the console at the clip locations until the clips engage.

H

In addition look for:

1. Loose harness or harness connectors.
2. Front console map/reading lamp lens loose.
3. Loose screws at console attachment points.

IP

## SEATS

When isolating seat noise it's important to note the position the seat is in and the load placed on the seat when the noise is present. These conditions should be duplicated when verifying and isolating the cause of the noise.

J

Cause of seat noise include:

1. Headrest rods and holder
2. A squeak between the seat pad cushion and frame
3. The rear seatback lock and bracket

K

These noises can be isolated by moving or pressing on the suspected components while duplicating the conditions under which the noise occurs. Most of these incidents can be repaired by repositioning the component or applying urethane tape to the contact area.

L

M

## UNDERHOOD

Some interior noise may be caused by components under the hood or on the engine wall. The noise is then transmitted into the passenger compartment.

Causes of transmitted underhood noise include:

1. Any component mounted to the engine wall
2. Components that pass through the engine wall
3. Engine wall mounts and connectors
4. Loose radiator mounting pins
5. Hood bumpers out of adjustment
6. Hood striker out of adjustment

These noises can be difficult to isolate since they cannot be reached from the interior of the vehicle. The best method is to secure, move or insulate one component at a time and test drive the vehicle. Also, engine RPM or load can be changed to isolate the noise. Repairs can usually be made by moving, adjusting, securing, or insulating the component causing the noise.

# SQUEAK AND RATTLE TROUBLE DIAGNOSES

EIS00977

## Diagnostic Worksheet

Dear Customer:

We are concerned about your satisfaction with your vehicle. Repairing a squeak or rattle sometimes can be very difficult. To help us fix your vehicle right the first time, please take a moment to note the area of the vehicle where the squeak or rattle occurs and under what conditions. You may be asked to take a test drive with a service advisor or technician to ensure we confirm the noise you are hearing.

### SQUEAK & RATTLE DIAGNOSTIC WORKSHEET

#### I. WHERE DOES THE NOISE COME FROM? (circle the area of the vehicle)

The illustrations are for reference only, and may not reflect the actual configuration of your vehicle.

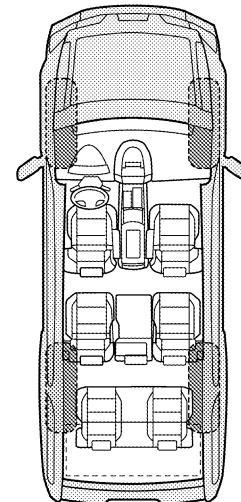
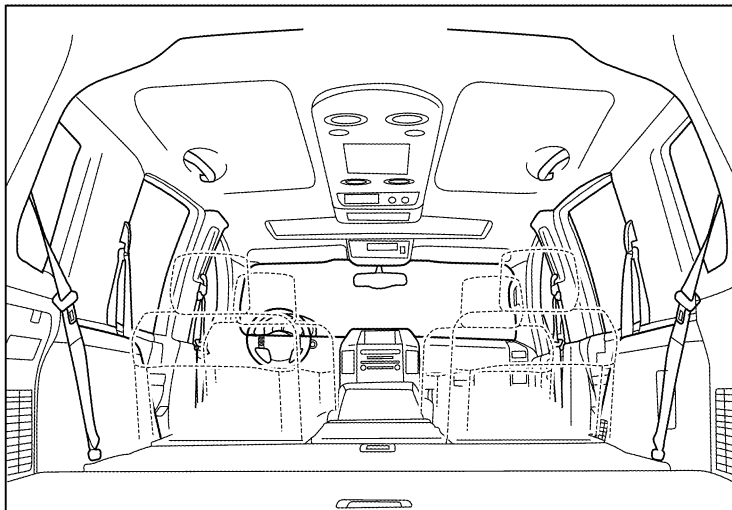
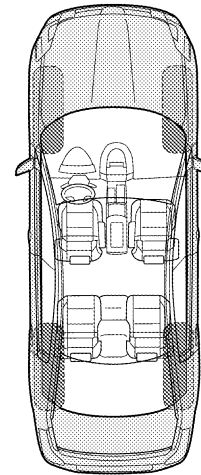
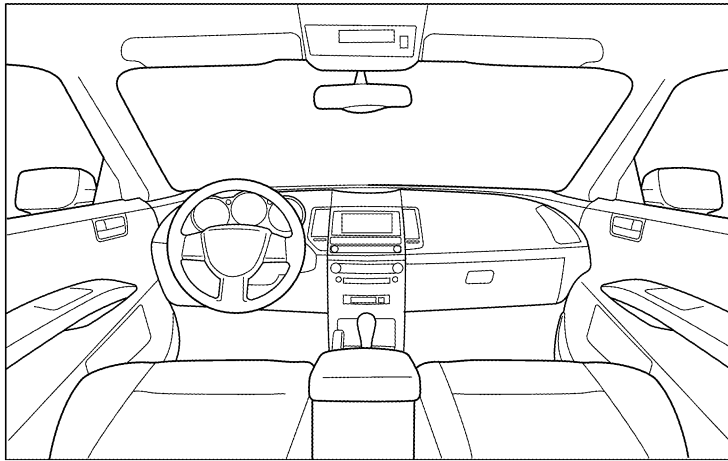

Continue to page 2 of the worksheet and briefly describe the location of the noise or rattle. In addition, please indicate the conditions which are present when the noise occurs.



# SQUEAK AND RATTLE TROUBLE DIAGNOSES

## SQUEAK & RATTLE DIAGNOSTIC WORKSHEET - page 2

Briefly describe the location where the noise occurs:

---

---

### II. WHEN DOES IT OCCUR? (please check the boxes that apply)

- |   |  |
|---|--|
| <input type="checkbox"/> Anytime                      | <input type="checkbox"/> After sitting out in the rain |
| <input type="checkbox"/> 1st time in the morning      | <input type="checkbox"/> When it is raining or wet     |
| <input type="checkbox"/> Only when it is cold outside | <input type="checkbox"/> Dry or dusty conditions       |
| <input type="checkbox"/> Only when it is hot outside  | <input type="checkbox"/> Other:                        |

### III. WHEN DRIVING:

- Through driveways
- Over rough roads
- Over speed bumps
- Only about \_\_\_\_ mph
- On acceleration
- Coming to a stop
- On turns: left, right or either (circle)
- With passengers or cargo
- Other: \_\_\_\_\_
- After driving \_\_\_\_ miles or \_\_\_\_ minutes

### IV. WHAT TYPE OF NOISE

- Squeak (like tennis shoes on a clean floor)
- Creak (like walking on an old wooden floor)
- Rattle (like shaking a baby rattle)
- Knock (like a knock at the door)
- Tick (like a clock second hand)
- Thump (heavy muffled knock noise)
- Buzz (like a bumble bee)

### TO BE COMPLETED BY DEALERSHIP PERSONNEL

#### Test Drive Notes:

---

---

---

	YES	NO	Initials of person performing
Vehicle test driven with customer	<input type="checkbox"/>	<input type="checkbox"/>	_____
- Noise verified on test drive	<input type="checkbox"/>	<input type="checkbox"/>	_____
- Noise source located and repaired	<input type="checkbox"/>	<input type="checkbox"/>	_____
- Follow up test drive performed to confirm repair	<input type="checkbox"/>	<input type="checkbox"/>	_____

VIN: \_\_\_\_\_ Customer Name \_\_\_\_\_

W.O.# \_\_\_\_\_ Date: \_\_\_\_\_

This form must be attached to Work Order

LAI0071E

# INSTRUMENT PANEL ASSEMBLY

## INSTRUMENT PANEL ASSEMBLY

PF6:68200

### Component Parts

EIS00978

SEC. 251•280•487•680•969

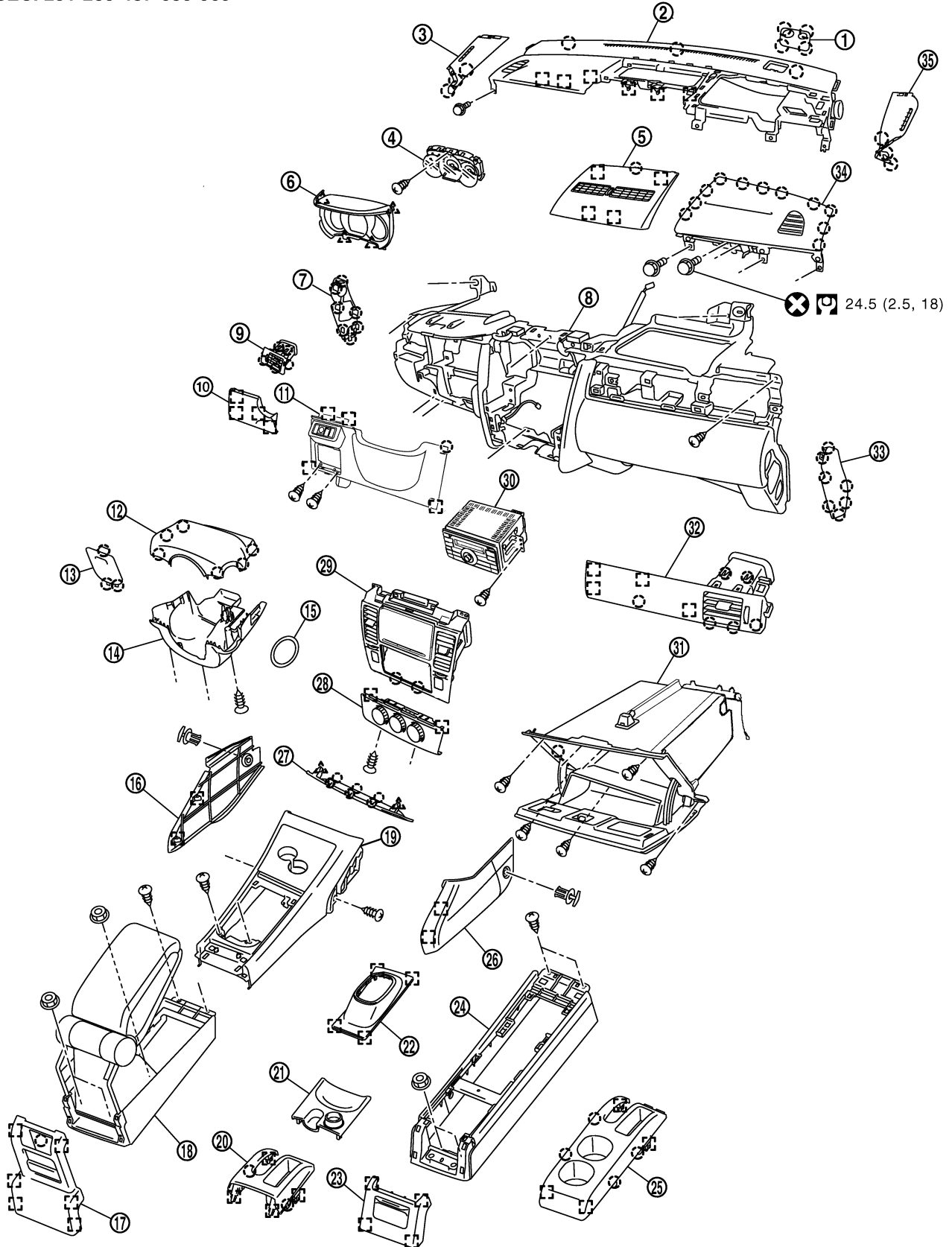

WIA1217E

# INSTRUMENT PANEL ASSEMBLY

- |  |   |  |
|--|---|--|
| 1. Instrument upper mask   | 2. Instrument upper panel assembly          | 3. Instrument side panel (LH)  |
| 4. Combination meter   | 5. Instrument finisher E                    | 6. Cluster lid A   |
| 7. Instrument side mask (LH)                                       | 8. Instrument panel & pad                   | 9. Side ventilator assembly (LH)   |
| 10. Instrument side finisher                                       | 11. Instrument lower finisher               | 12. Steering column cover upper  |
| 13. Fuse block lid   | 14. Steering column cover lower             | 15. Steering lock escutcheon   |
| 16. Instrument lower cover (LH)                                    | 17. Console rear finisher (with armrest)    | 18. Console body assembly (with armrest)   |
| 19. Center console   | 20. Console mask cover (with armrest)       | 21. Console mask   |
| 22. A/T console finisher / M/T console boot / CVT console finisher | 23. Console rear finisher (without armrest) | 24. Console body assembly (without armrest)  |
| 25. Rear cup holder (without armrest)                              | 26. Instrument lower cover (RH)             | 27. Instrument finisher D  |
| 28. Controller   | 29. Cluster lid C                           | 30. Audio unit   |
| 31. Glove box assembly   | 32. Side ventilator assembly (RH)           | 33. Instrument side mask (RH)  |
| 34. Passenger air bag module assembly                              | 35. Instrument side panel (RH)              |  Pawl |

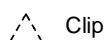

Clip



Metal clip

## Removal and Installation WORK STEPS

EIS00979

When removing instrument panel & pad, cluster lid A, cluster lid C, passenger air bag module assembly and center console assembly, follow steps in the order shown.

### CAUTION:

- **Disconnect both battery cables.**
- **Never tamper with or force air bag lid open, as this may adversely affect air bag performance.**
- **Be careful not to scratch pad and other parts.**

Parts	Reference page	Instrument panel and pad	Cluster lid A	Cluster lid C	Passenger air bag module assembly	Center console assembly
Instrument finisher E	<a href="#">IP-12</a>	[ 1 ]	[ 1 ]	[ 1 ]		
Cluster lid C	<a href="#">IP-18</a>	[ 2 ]		[ 2 ]		
Audio unit	<a href="#">AV-43</a>	[ 3 ]				
Front pillar garnish (LH/RH)	<a href="#">EI-32</a>	[ 4 ]	[ 2 ]		[ 1 ]	
Instrument side panel (LH/RH)	<a href="#">IP-10</a>	[ 5 ]	[ 3 ]		[ 2 ]	
Instrument side mask (LH/RH)	<a href="#">IP-10</a>	[ 6 ]	[ 4 ]		[ 3 ]	
Instrument side finisher	<a href="#">IP-10</a>	[ 7 ]	[ 5 ]			
Side ventilator assembly (LH)	<a href="#">IP-10</a>	[ 8 ]	[ 6 ]			
Steering lock escutcheon	<a href="#">IP-10</a>	[ 9 ]				
Steering column cover upper	<a href="#">IP-10</a>	[ 10 ]	[ 7 ]			
Steering column cover lower	<a href="#">IP-10</a>	[ 11 ]				
Cluster lid A	<a href="#">IP-16</a>	[ 12 ]	[ 8 ]			
Combination meter	<a href="#">DI-23</a>	[ 13 ]				
Instrument lower finisher	<a href="#">IP-21</a>	[ 14 ]				
Glove box assembly	<a href="#">IP-21</a>	[ 15 ]				
Side ventilator assembly (RH)	<a href="#">IP-10</a>	[ 16 ]			[ 4 ]	
Passenger air bag module assembly	<a href="#">SRS-46</a>	[ 17 ]			[ 5 ]	
Instrument upper mask	<a href="#">IP-10</a>	[ 18 ]				
Instrument finisher D	<a href="#">IP-10</a>	[ 19 ]				
Controller	<a href="#">MTC-61</a>	[ 20 ]				
Instrument upper panel assembly	<a href="#">IP-10</a>	[ 21 ]				

# INSTRUMENT PANEL ASSEMBLY

Parts	Reference page	Instrument panel and pad	Cluster lid A	Cluster lid C	Passenger air bag module assembly	Center console assembly
Console mask	<a href="#">IP-22</a>	[ 22 ]				[ 1 ]
CVT, A/T console finisher	<a href="#">IP-25</a>	[ 23 ]				[ 2 ]
M/T console boot	<a href="#">IP-25</a>	[ 23 ]				[ 2 ]
Console rear finisher	<a href="#">IP-25</a>	[ 24 ]				[ 3 ]
Console mask cover (with arm rest)	<a href="#">IP-25</a>	[ 25 ]				[ 4 ]
Rear cup holder (without arm rest)	<a href="#">IP-25</a>	[ 25 ]				[ 4 ]
Console body assembly	<a href="#">IP-25</a>	[ 26 ]				[ 5 ]
Instrument lower cover (LH/RH)	<a href="#">IP-21</a>	[ 27 ]				[ 6 ]
Center console assembly	<a href="#">IP-22</a>	[ 28 ]				[ 7 ]
Fuse block lid	<a href="#">IP-10</a>	[ 29 ]				
Lighting and turn signal switch	<a href="#">LT-65</a>	[ 30 ]				
Wiper & washer switch	<a href="#">WW-28</a>	[ 31 ]				
Instrument panel & pad	<a href="#">IP-10</a>	[ 32 ]				

[ ]: Number indicates step in removal procedures.

## INSTRUMENT PANEL ASSEMBLY

### Removal

1. Pull instrument finisher E backward by approximately 30 degrees while disengaging the instrument finisher E metal clips and pawl.

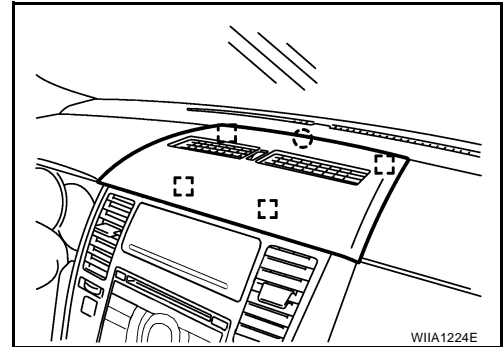

2. Remove cluster lid C.
  - a. Remove cluster lid C screws.
  - b. Pull back and disengage pawls and cluster lid C metal clips.
  - c. Disconnect harness connector and then remove cluster lid C.

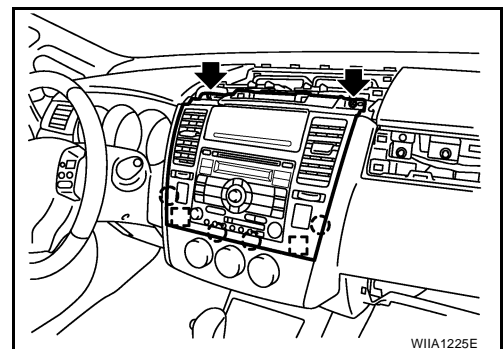

3. Remove audio unit. Refer to [AV-43, "Removal and Installation"](#).
4. Remove front pillar garnish. Refer to [EI-32, "BODY SIDE TRIM"](#).

# INSTRUMENT PANEL ASSEMBLY

5. Remove the side panel (LH/RH).
  - a. Pull up instrument side panel and disengage pawls.
  - b. Remove instrument side panel.

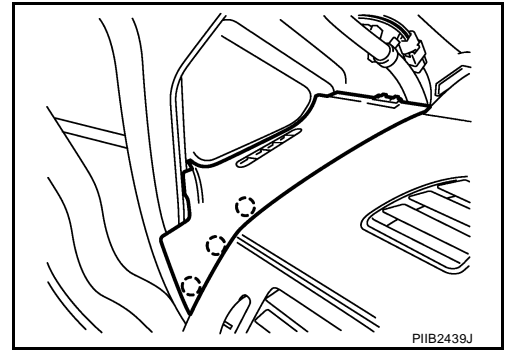

6. Remove instrument side mask (LH/RH).
  - a. Insert a suitable tool into upper space of instrument mask.
  - b. Disengage pawls, and then remove instrument side mask.

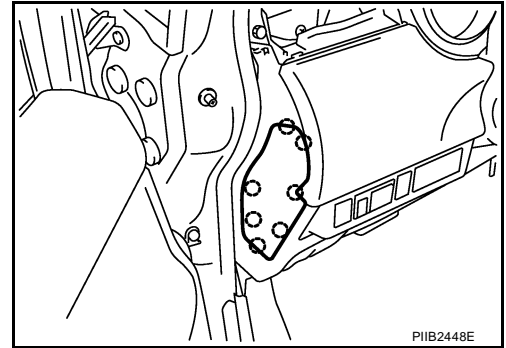

7. Remove instrument side finisher.
  - a. Insert a suitable tool into space of instrument side finisher.
  - b. Disengage instrument side finisher metal clips, and then remove instrument side finisher.

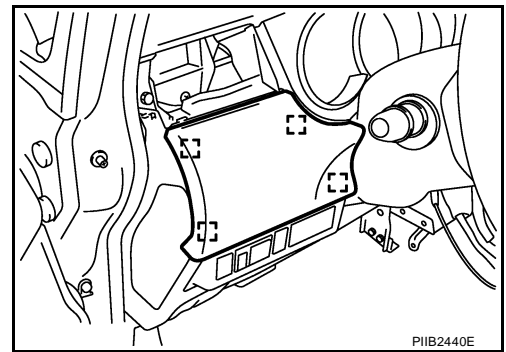

8. Remove side ventilator assembly (LH).
  - a. Insert a suitable tool into the bottom gap of side ventilator assembly after removing the instrument side mask and push against A and B as shown to disengage the pawls.

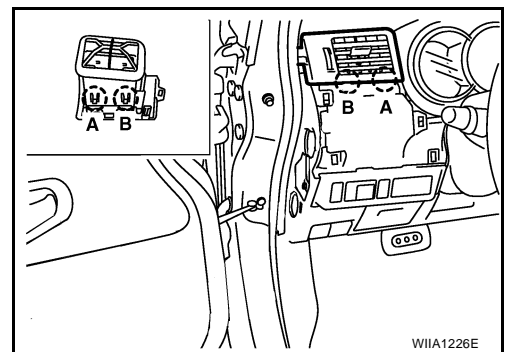

- b. Lift the side ventilator up from the bottom, pull backward while disengaging the side ventilator assembly upper pawls, and then remove the side ventilator.

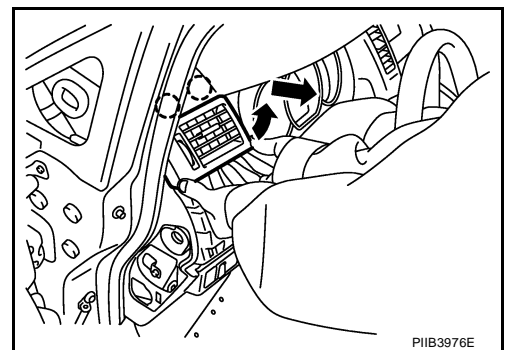

A  
B  
C  
D  
E  
F  
G  
H  
IP  
J  
K  
L  
M

# INSTRUMENT PANEL ASSEMBLY

9. Remove steering lock escutcheon.
10. Remove screws, and disengage pawls then remove the steering column cover.
11. Remove cluster lid A.
  - a. Remove screws from instrument upper panel right side.

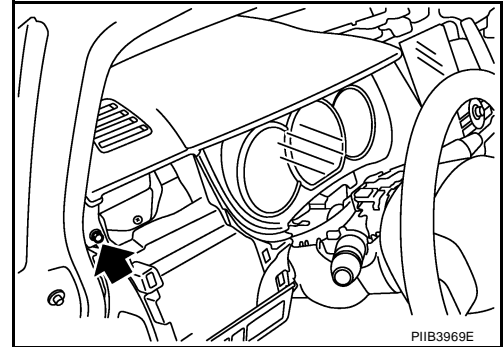

- b. Lift the instrument upper panel up, disengage metal clips.
  - c. Pull backward and disengage clips.
  - d. Remove cluster lid A.

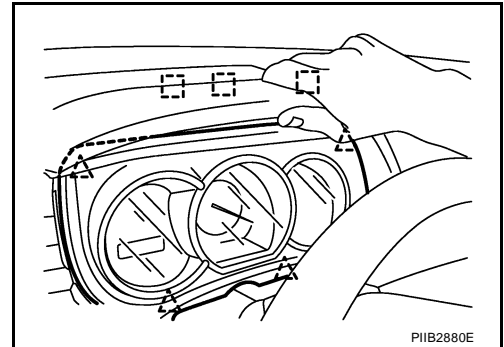

12. Remove combination meter. Refer to [DI-23, "Removal and Installation"](#).

13. Remove instrument lower finisher.
  - a. Disengage pawls and remove fuse block lid.
  - b. Remove the screws.
  - c. Pull backward while disengaging the instrument lower finisher clip and pawls.
  - d. Disconnect in-vehicle sensor and harness connector, and then remove instrument lower finisher.

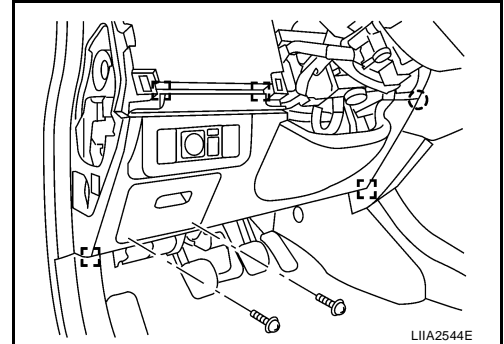

14. Remove glove box. Refer to [IP-24, "GLOVE BOX ASSEMBLY"](#).

15. Remove side ventilator assembly.
  - a. Insert a suitable tool into the side ventilator assembly from center console side, disengage the clips and pawl of instrument panel pad.

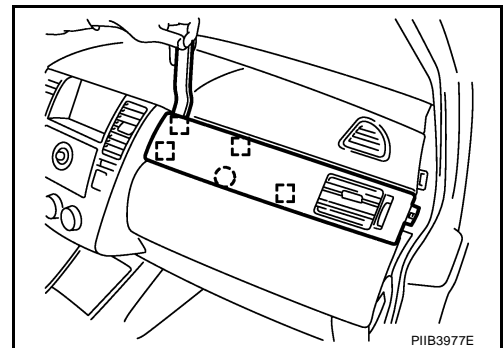

# INSTRUMENT PANEL ASSEMBLY

- b. Reach through the glove box compartment by hand to the back-side of the side ventilator and push against A as shown to engage the pawl.
- c. Insert a suitable tool into the bottom gap of side ventilator assembly after removing the instrument side mask and push against B as shown to disengage the pawl.

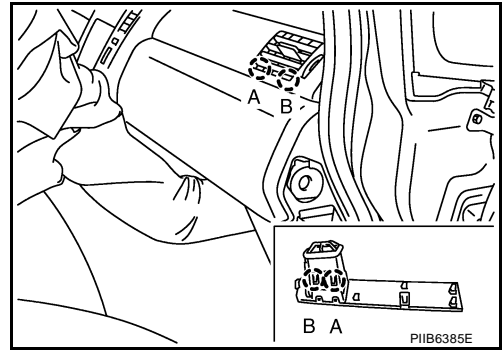

- d. Lift the side ventilator assembly up from the bottom, pull backward while disengaging the side ventilator assembly upper pawls, and then remove the side ventilator assembly.

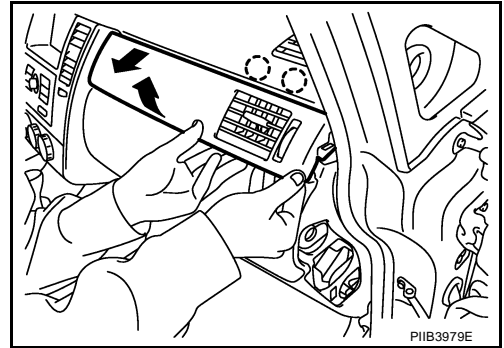

- 16. Remove front passenger air bag module. Refer to [SRS-46, "FRONT PASSENGER AIR BAG MODULE"](#) .

- 17. Remove instrument upper mask.

- a. Insert a remover into backside space of instrument upper mask.
- b. Disconnect harness connector, and then remove instrument upper mask.

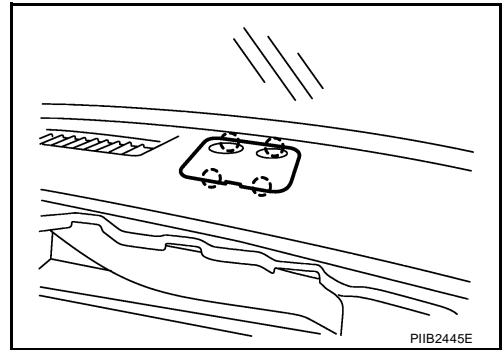

- 18. Remove instrument finisher D.

- a. Insert a remover into upper space of instrument finisher D.
- b. Disengage clips and pawls, then remove instrument finisher D.

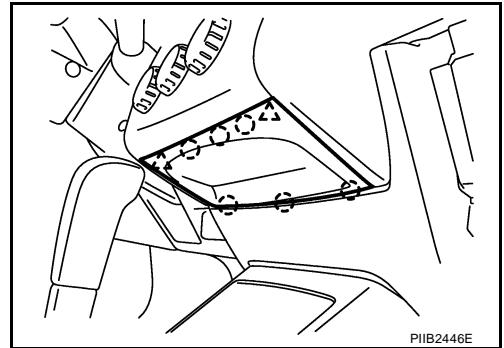

- 19. Remove controller. Refer to [MTC-61, "CONTROLLER"](#) .

A  
B  
C  
D  
E  
F  
G  
H  
IP  
J  
K  
L  
M

# INSTRUMENT PANEL ASSEMBLY

20. Remove instrument upper panel assembly.
  - a. Remove bolts and screws.
  - b. Pull backward and remove instrument upper panel assembly.

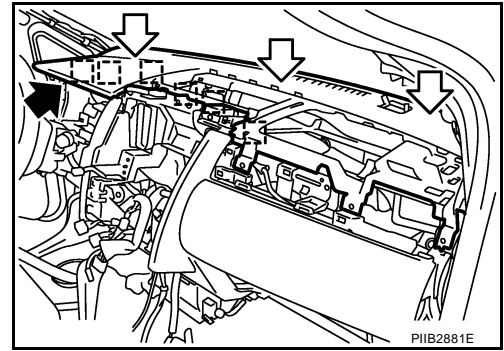

21. Remove lighting & turn signal switch. Refer to [LT-65, "LIGHTING AND TURN SIGNAL SWITCH"](#) .
22. Remove wiper & washer switch. Refer to [WW-28, "Removal and Installation of Front Wiper and Washer Switch"](#) .
23. Remove hood opener handle and fuel filler lid opener handle. Refer to [BL-17, "Removal and Installation of Hood Lock Control"](#) .
24. Remove screws, and then remove instrument panel & pad from passenger door opening portion.

## Installation

Installation is in the reverse order of removal.

## CLUSTER LID A

### Removal

1. Pull instrument finisher E backward by approximately 30 degrees while disengaging the metal clips and pawl.

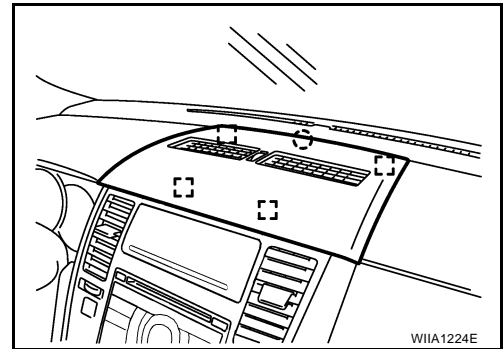

2. Remove front pillar garnish. Refer to [EI-32, "BODY SIDE TRIM"](#) .
3. Pull up instrument side panel and disengage pawls.
4. Remove instrument side panel.

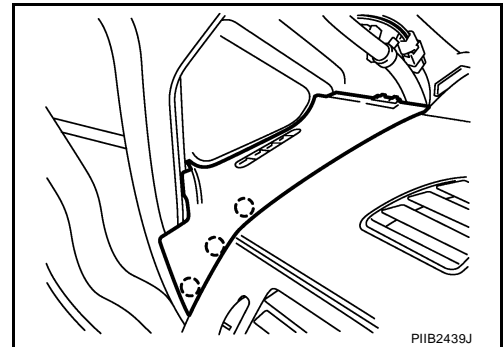



# INSTRUMENT PANEL ASSEMBLY

5. Insert a remover into upper space of instrument mask.
6. Disengage pawls, and then remove instrument side mask.

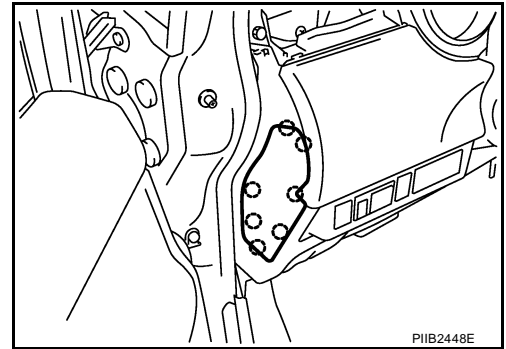

7. Insert a remover into space of instrument side finisher.
8. Disengage metal clips, and then remove instrument side finisher.

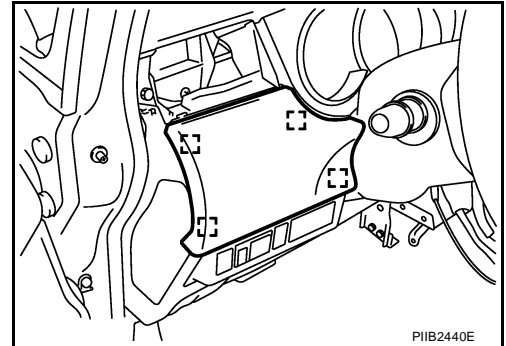

9. Insert suitable tool into the bottom gap of side ventilator assembly after removing the instrument side mask, push against A and B as shown to disengage the pawls.

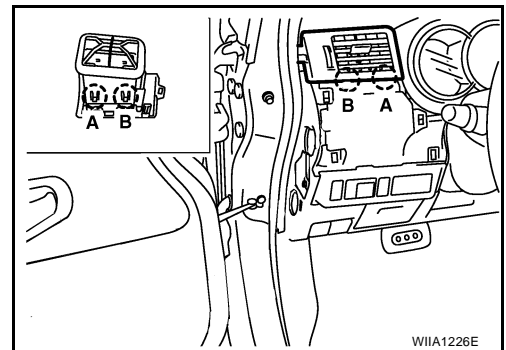

10. Lift the side ventilator up from the bottom, pull backward while disengaging the side ventilator assembly's upper pawls, and then remove the side ventilator.

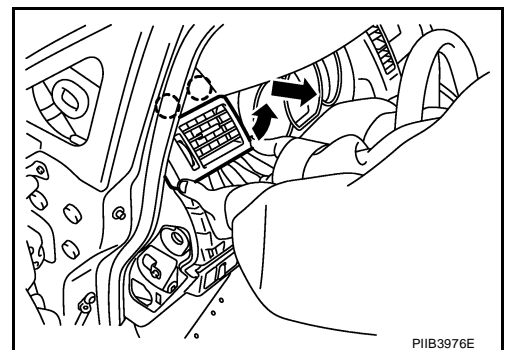

11. Remove screws, and disengage pawls.
12. Remove steering column cover upper.

A  
B  
C  
D  
E  
F  
G  
H  
IP  
J  
K  
L  
M

# INSTRUMENT PANEL ASSEMBLY

13. Remove screws from instrument upper panel right side.

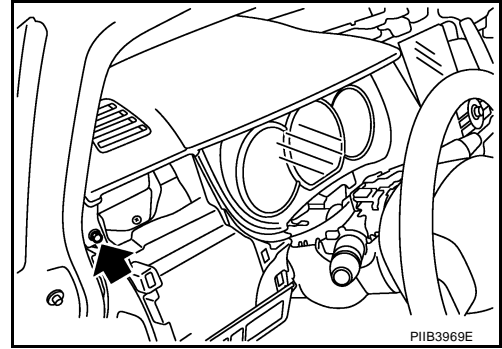

14. Lift the instrument upper panel up, disengage metal clips.

15. Pull backward and disengage clips.

16. Remove cluster lid A.

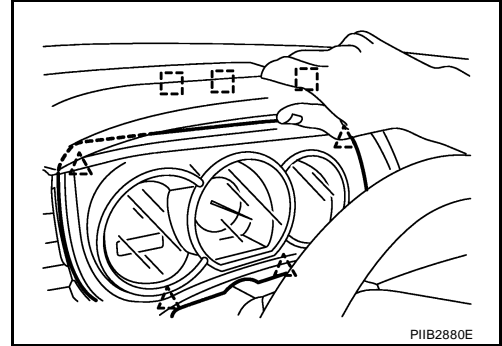

## Installation

Installation is in the reverse order of removal.

## CLUSTER LID C

### Removal

1. Pull instrument finisher E backward by approximately 30 degrees while disengaging the metal clips and pawl.

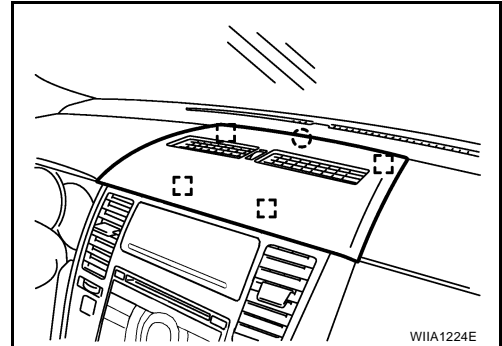

2. Remove screws.

3. Pull back, and disengage pawls and metal clips.

4. Disconnect harness connector, and then remove cluster lid C.

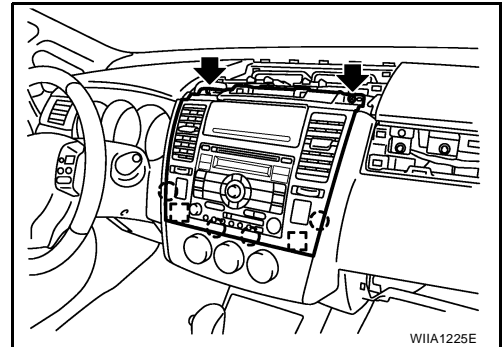

## Installation

Installation is in the reverse order of removal.

# INSTRUMENT PANEL ASSEMBLY

## COMBINATION METER

### Removal

1. Pull instrument finisher E backward by approximately 30 degrees while disengaging the metal clips and pawl.

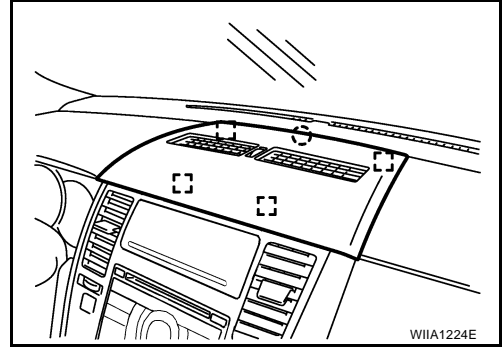

2. Remove front pillar garnish. Refer to [EI-32, "BODY SIDE TRIM"](#).
3. Pull up instrument side panel and disengage pawls.
4. Remove instrument side panel.

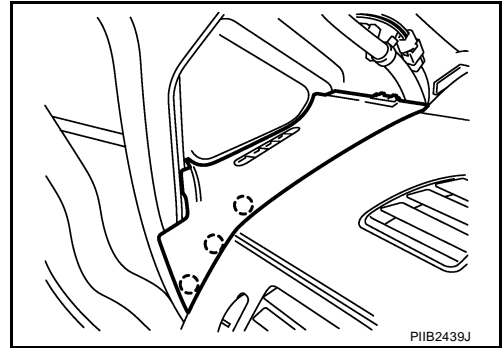

5. Insert a remover into upper space of instrument mask.
6. Disengage pawls, and then remove instrument side mask.

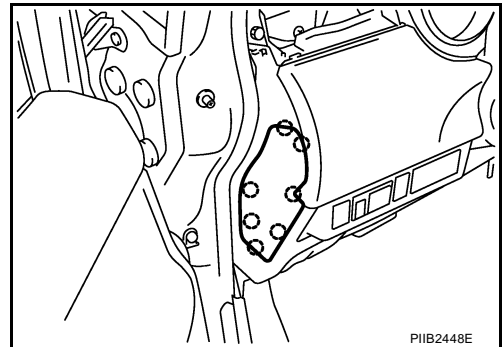

7. Insert a remover into space of instrument side finisher.
8. Disengage metal clips, and then remove instrument side finisher.

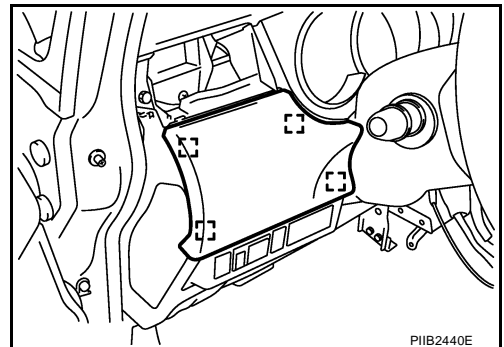

A  
B  
C  
D  
E  
F  
G  
H  
IP  
J  
K  
L  
M

# INSTRUMENT PANEL ASSEMBLY

9. Insert suitable tool into the bottom gap of side ventilator assembly after removing the instrument side mask, push against A and B as shown to disengage the pawls.

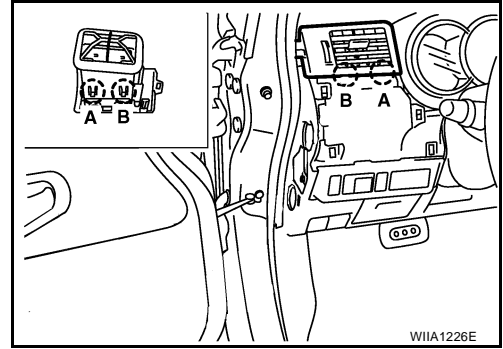

10. Lift the side ventilator up from the bottom, pull backward while disengaging the side ventilator assembly's upper pawls, and then remove the side ventilator.

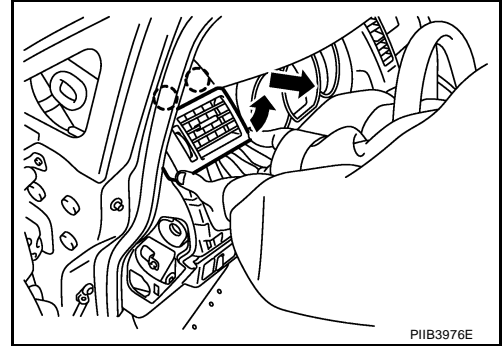

11. Remove screws, and disengage pawls.  
12. Remove steering column cover upper.  
13. Remove screws from instrument upper panel right side.

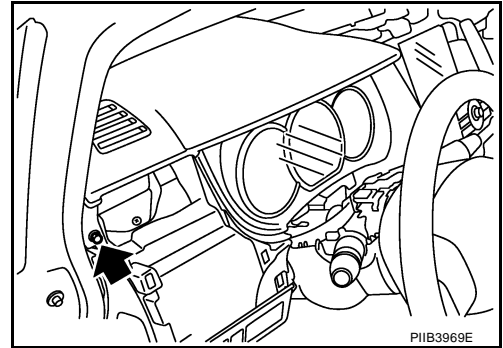

14. Lift the instrument upper panel up, disengage metal clips.  
15. Pull backward and disengage clips.  
16. Remove cluster lid A.

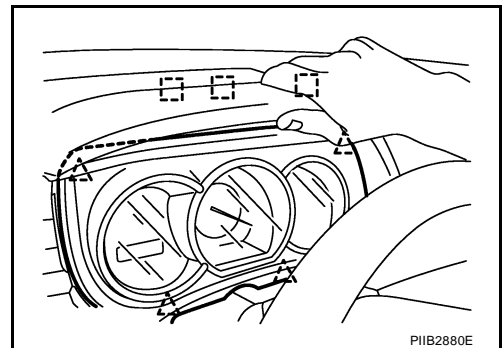

# INSTRUMENT PANEL ASSEMBLY

17. Remove screws (A) and metal clip (B), and remove combination meter.

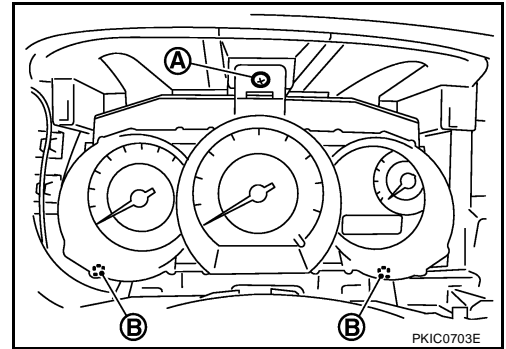

## Installation

Installation is in the reverse order of removal.

## GLOVE BOX ASSEMBLY

### Removal

1. Remove glove box screws.
2. Pull backward while disengaging the glove box assembly pawls.
3. Disconnect lamp harness connector, and then remove glove box assembly.

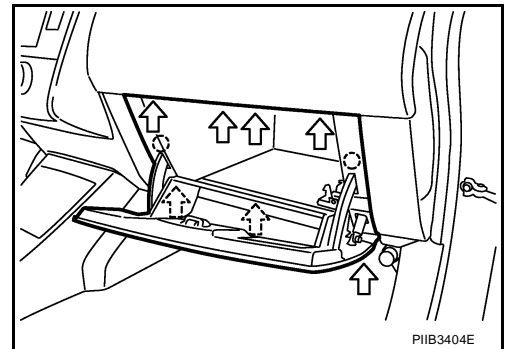

## Installation

Installation is in the reverse order of removal.

## INSTRUMENT LOWER FINISHER

### Removal

1. Pull backward while disengage the instrument lower finisher's clip and pawls.
2. Disconnect in-vehicle sensor and harness connector, and then remove instrument lower finisher.

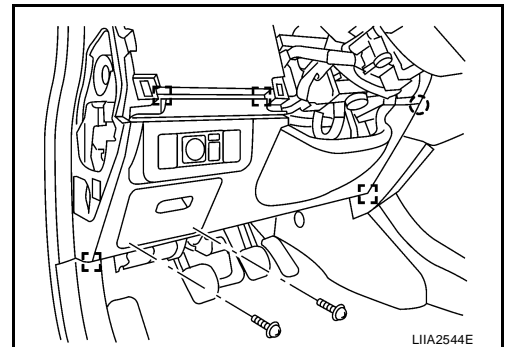

## Installation

Installation is in the reverse order of removal.

A  
B  
C  
D  
E  
F  
G  
H  
IP  
J  
K  
L  
M

# INSTRUMENT PANEL ASSEMBLY

## CENTER CONSOLE ASSEMBLY

### Removal

1. Insert a suitable tool into front side space of console mask, and disengage metal clips.
2. Disconnect harness connector, and then remove console mask.

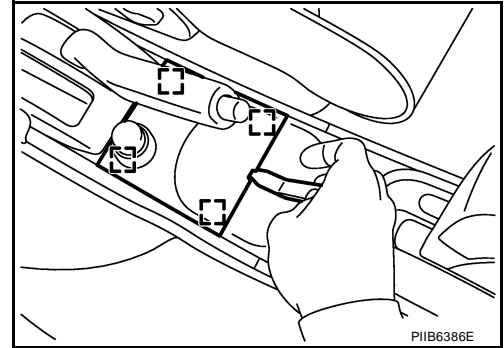

3. Place the selector lever in "D" position (A/T and CVT only).
4. Remove selector lever knob (A/T and CVT only). Refer to [CVT-191, "Removal and Installation"](#) (CVT), [AT-229, "Control Device Removal and Installation"](#) (A/T).
5. Pull up and disengage A/T and CVT console finisher metal clips (A/T and CVT only).
6. Remove A/T and CVT console finisher (A/T and CVT only).

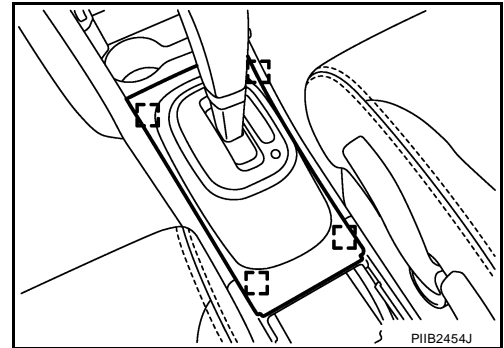

7. Remove shift knob (M/T only). Refer to [MT-48, "SHIFT CONTROL"](#).
8. Pull up and disengage M/T console boot metal clips (M/T only).
9. Remove M/T console boot (M/T only).
10. Disengage console rear finisher metal clips and pawl.
11. Remove console rear finisher.

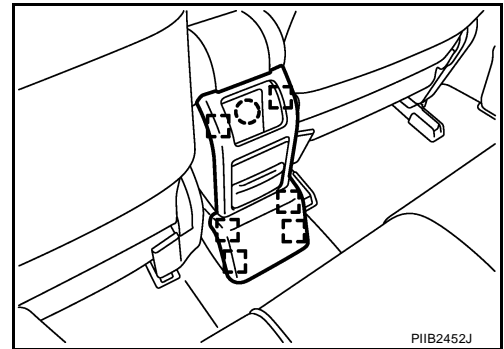

12. Disengage console mask cover metal clips and pawls, and then remove console mask cover (with armrest).

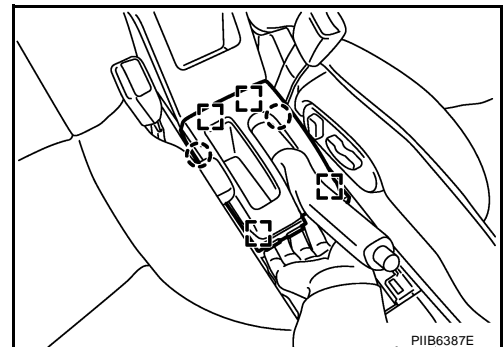

# INSTRUMENT PANEL ASSEMBLY

13. Disengage rear cup holder metal clips and pawls (without armrest).
14. Remove rear cup holder (without armrest).

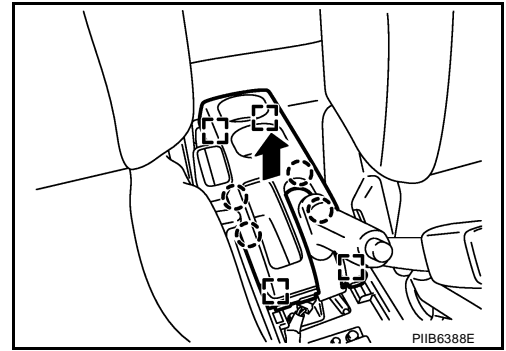

15. Remove console body assembly screws and nut.
16. Disconnect harness connector, and then remove console body assembly.
17. Remove both of the instrument lower cover LH and RH clips.
18. Disengage instrument lower cover LH and RH metal clips and remove both of the instrument lower cover LH and RH.

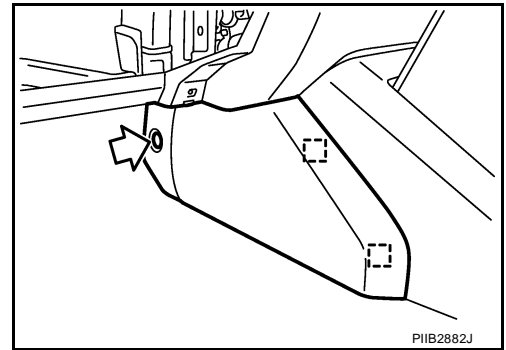

19. Remove screws and then remove center console.

## Installation

Installation is in the reverse order of removal.

A  
B  
C  
D  
E  
F  
G  
H  
IP  
J  
K  
L  
M

# INSTRUMENT PANEL ASSEMBLY

EIS0097A

## Disassembly and Assembly GLOVE BOX ASSEMBLY

SEC. 680

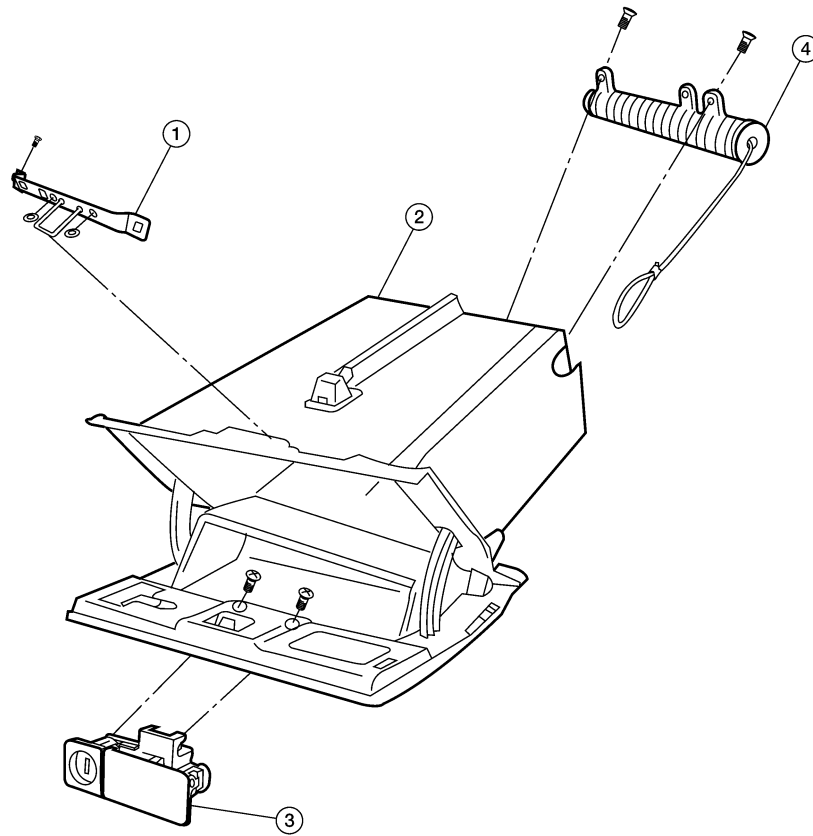

LIA2555E

1. Glove box striker
2. Glove box
3. Glove box latch
4. Damper

### Disassembly

1. Remove screws of damper, and then remove damper.
2. Remove screws of glove box striker, and then remove glove box striker.
3. Remove screws of glove box latch, and then remove glove box latch.

### Assembly

Assembly is in the reverse order of disassembly.



# INSTRUMENT PANEL ASSEMBLY

## CENTER CONSOLE ASSEMBLY

SEC. 969

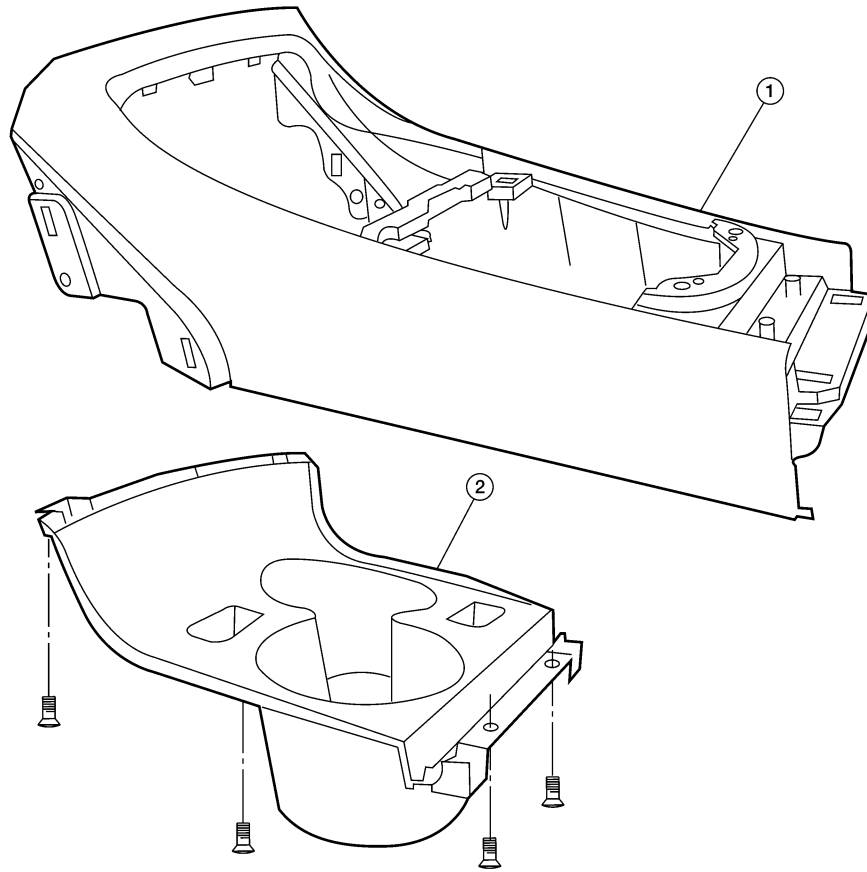

1. Center console

2. Front cup holder

LIA2556E

### Disassembly

Remove the four screws, and then remove front cup holder from center console.

### Assembly

Assembly is in the reverse order of disassembly.

## COMBINATION METER

### Disassembly

Disengage the eight tabs to separate front cover (1) from the unified meter control unit assembly (2).

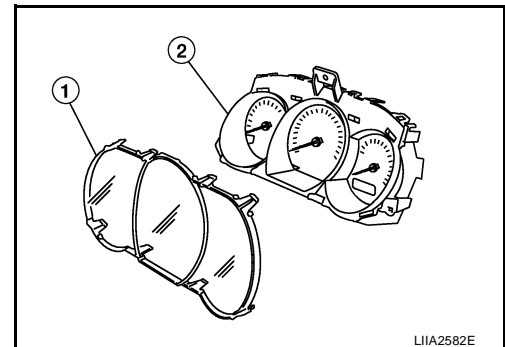

LIA2582E

### Assembly

Assembly is in the reverse order of disassembly.

A  
B  
C  
D  
E  
F  
G  
H  
IP  
J  
K  
L  
M

# INSTRUMENT PANEL ASSEMBLY

---