

**SECTION GW**

**GLASSES, WINDOW SYSTEM & MIRRORS**

**CONTENTS**

<b>PRECAUTIONS</b> .....	<b>3</b>	Component Parts and Harness Connector Location..	17	F
Precautions for Supplemental Restraint System (SRS) "AIR BAG" and "SEAT BELT PRE-TENSIONER" .....	3	System Description .....	17	
Precautions for Procedures without Cowl Top Cover... 3		<b>MANUAL OPERATION</b> .....	18	B
Handling for Adhesive and Primer .....	3	<b>AUTO OPERATION</b> .....	20	G
<b>PREPARATION</b> .....	<b>4</b>	<b>POWER WINDOW LOCK</b> .....	21	
Commercial Service Tools .....	4	<b>RETAINED POWER OPERATION</b> .....	21	D
<b>SQUEAK AND RATTLE TROUBLE DIAGNOSES</b> .....	<b>5</b>	CAN Communication System Description .....	21	E
Work Flow .....	5	Schematic .....	22	
<b>CUSTOMER INTERVIEW</b> .....	5	Wiring Diagram — WINDOW — .....	23	F
<b>DUPLICATE THE NOISE AND TEST DRIVE</b> .....	6	Main Power Window and Door Lock/Unlock Switch		
<b>CHECK RELATED SERVICE BULLETINS</b> .....	6	Harness Connector Terminal Layout .....	27	G
<b>LOCATE THE NOISE AND IDENTIFY THE ROOT CAUSE</b> .....	6	Terminal and Reference Value for Main Power Window and Door Lock/Unlock Switch .....	27	H
<b>REPAIR THE CAUSE</b> .....	6	Terminal and Reference Value for BCM .....	28	J
<b>CONFIRM THE REPAIR</b> .....	7	Work Flow .....	28	
Generic Squeak and Rattle Troubleshooting .....	7	<b>CONSULT-II Function (BCM)</b> .....	28	K
<b>INSTRUMENT PANEL</b> .....	7	<b>CONSULT-II START PROCEDURE</b> .....	28	
<b>CENTER CONSOLE</b> .....	7	<b>ACTIVE TEST</b> .....	29	L
<b>DOORS</b> .....	7	<b>WORK SUPPORT</b> .....	29	
<b>TRUNK</b> .....	8	<b>DATA MONITOR</b> .....	29	M
<b>SUNROOF/HEADLINING</b> .....	8	Trouble Diagnoses Symptom Chart .....	29	
<b>OVERHEAD CONSOLE (FRONT AND REAR)</b> .....	8	BCM Power Supply and Ground Circuit Check .....	30	
<b>SEATS</b> .....	8	Main Power Window and Door Lock/Unlock Switch		
<b>UNDERHOOD</b> .....	8	Power Supply and Ground Circuit Check .....	30	
Diagnostic Worksheet .....	9	Front Power Window Motor LH Circuit Check .....	32	
<b>WINDSHIELD GLASS</b> .....	<b>11</b>	Front Power Window RH Circuit Check (Power Window and Door Lock/Unlock Switch RH Operation)..	33	
Removal and Installation .....	11	Front Power Window Motor RH Circuit Check .....	33	
<b>REMOVAL</b> .....	11	Encoder Circuit Check .....	34	
<b>INSTALLATION</b> .....	12	Door Switch Check .....	37	
<b>OPERA WINDOW GLASS</b> .....	<b>13</b>	Rear Power Window LH Circuit Check (Rear Power Window Switch LH Operation) .....	38	
Removal and Installation .....	13	Rear Power Window RH Circuit Check (Rear Power Window Switch RH Operation) .....	39	
<b>REMOVAL</b> .....	13	Rear Power Window Motor LH Circuit Check .....	39	
<b>INSTALLATION</b> .....	13	Rear Power Window Motor RH Circuit Check .....	41	
<b>REAR WINDOW GLASS AND MOLDING</b> .....	<b>15</b>	<b>FRONT DOOR GLASS AND REGULATOR</b> .....	<b>43</b>	
Removal and Installation .....	15	Removal and Installation .....	43	
<b>REMOVAL</b> .....	15	<b>DOOR GLASS</b> .....	43	
<b>INSTALLATION</b> .....	16	<b>REGULATOR ASSEMBLY</b> .....	44	
<b>POWER WINDOW SYSTEM</b> .....	<b>17</b>			

Disassembly and Assembly .....	45	CONSULT-II START PROCEDURE .....	55
POWER WINDOW REGULATOR ASSEMBLY ...	45	DATA MONITOR .....	55
Inspection after Installation .....	45	ACTIVE TEST .....	55
POWER WINDOW SYSTEM INITIALIZATION ...	45	Trouble Diagnoses Symptom Chart .....	55
INSPECT THE FUNCTION OF THE ANTI-		BCM Power Supply and Ground Circuit Check .....	56
PINCH SYSTEM .....	46	Rear Window Defogger Switch Circuit Check .....	56
FITTING INSPECTION .....	46	Rear Window Defogger Circuit Check .....	57
<b>REAR DOOR GLASS AND REGULATOR .....</b>	<b>47</b>	Door Mirror Defogger Circuit Check .....	60
Removal and Installation .....	47	Filament Check .....	61
DOOR GLASS .....	47	Filament Repair .....	62
REGULATOR ASSEMBLY .....	48	REPAIR EQUIPMENT .....	62
Disassembly and Assembly .....	49	REPAIRING PROCEDURE .....	62
POWER WINDOW REGULATOR ASSEMBLY ...	49	<b>DOOR MIRROR .....</b>	<b>64</b>
Inspection after Installation .....	49	Wiring Diagram — MIRROR — .....	64
FITTING INSPECTION .....	49	Removal and Installation .....	65
<b>REAR WINDOW DEFOGGER .....</b>	<b>50</b>	REMOVAL .....	65
Component Parts and Harness Connector Location..	50	INSTALLATION .....	65
System Description .....	50	Disassembly and Assembly .....	66
CAN Communication System Description .....	51	DISASSEMBLY .....	66
Wiring Diagram — DEF — .....	52	ASSEMBLY .....	66
Terminals and Reference Value for BCM .....	54	<b>INSIDE MIRROR .....</b>	<b>67</b>
Terminals and Reference Value for IPDM E/R .....	54	Removal and Installation .....	67
Work Flow .....	54	REMOVAL .....	67
CONSULT-II Function (BCM) .....	55	INSTALLATION .....	67

# PRECAUTIONS

## PRECAUTIONS

PFP:00001

### Precautions for Supplemental Restraint System (SRS) “AIR BAG” and “SEAT BELT PRE-TENSIONER”

EIS009DX

The Supplemental Restraint System such as “AIR BAG” and “SEAT BELT PRE-TENSIONER”, used along with a front seat belt, helps to reduce the risk or severity of injury to the driver and front passenger for certain types of collision. This system includes seat belt switch inputs and dual stage front air bag modules. The SRS system uses the seat belt switches to determine the front air bag deployment, and may only deploy one front air bag, depending on the severity of a collision and whether the front occupants are belted or unbelted. Information necessary to service the system safely is included in the SRS and SB section of this Service Manual.

#### **WARNING:**

- To avoid rendering the SRS inoperative, which could increase the risk of personal injury or death in the event of a collision which would result in air bag inflation, all maintenance must be performed by an authorized NISSAN/INFINITI dealer.
- Improper maintenance, including incorrect removal and installation of the SRS, can lead to personal injury caused by unintentional activation of the system. For removal of Spiral Cable and Air Bag Module, see the SRS section.
- Do not use electrical test equipment on any circuit related to the SRS unless instructed to in this Service Manual. SRS wiring harnesses can be identified by yellow and/or orange harnesses or harness connectors.

### Precautions for Procedures without Cowl Top Cover

EIS009DY

When performing the procedure after removing cowl top cover, cover the lower end of windshield.

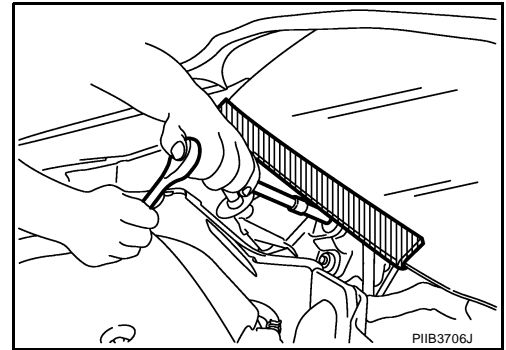

### Handling for Adhesive and Primer

EIS00947

- Do not use an adhesive which is past its usable date. Shelf life of the adhesive is limited to six months after the date of manufacture. Carefully adhere to the expiration or manufacture date printed on the box.
- Keep primers and adhesive in a cool, dry place. Ideally, they should be stored in a refrigerator.
- Open the seal of the primer and adhesive just before application. Discard the remainder after application.
- Before application, be sure to shake the primer container to stir the contents. If any floating material is found, do not use it.
- If any primer or adhesive contacts the skin, wipe it off with gasoline or equivalent and wash the skin with soap.
- When using primer and adhesive, always observe the precautions in the instruction manual.

A  
B  
C  
D  
E  
F  
G  
H  
J  
K  
L  
M

GW

# PREPARATION

## PREPARATION

PF0:00002

### Commercial Service Tools

EIS00949

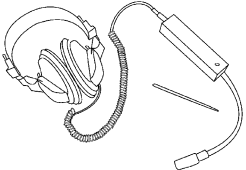
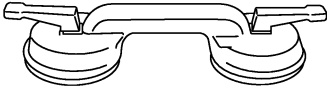
Tool name	Description
<p data-bbox="191 394 305 422">Engine ear</p>  <p data-bbox="802 499 867 512">SIA0995E</p>	<p data-bbox="1003 394 1187 422">Locating the noise</p>
<p data-bbox="191 630 321 657">Suction lifter</p>  <p data-bbox="802 730 867 743">PIB1805J</p>	<p data-bbox="1003 630 1214 657">Holding of door glass</p>

# SQUEAK AND RATTLE TROUBLE DIAGNOSES

## SQUEAK AND RATTLE TROUBLE DIAGNOSES

PF0:0000

### Work Flow

EIS009DZ

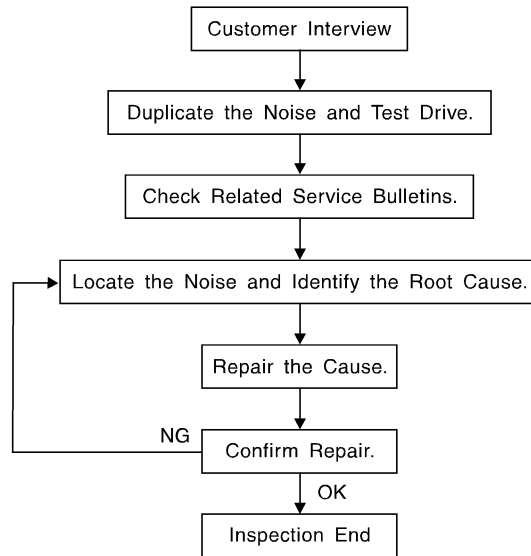

SBT842

### CUSTOMER INTERVIEW

Interview the customer if possible, to determine the conditions that exist when the noise occurs. Use the Diagnostic Worksheet during the interview to document the facts and conditions when the noise occurs and any customer's comments; refer to [GW-9, "Diagnostic Worksheet"](#). This information is necessary to duplicate the conditions that exist when the noise occurs.

- The customer may not be able to provide a detailed description or the location of the noise. Attempt to obtain all the facts and conditions that exist when the noise occurs (or does not occur).
- If there is more than one noise in the vehicle, be sure to diagnose and repair the noise that the customer is concerned about. This can be accomplished by test driving the vehicle with the customer.
- After identifying the type of noise, isolate the noise in terms of its characteristics. The noise characteristics are provided so the customer, service adviser and technician are all speaking the same language when defining the noise.
- Squeak —(Like tennis shoes on a clean floor)  
Squeak characteristics include the light contact/fast movement/brought on by road conditions/hard surfaces = higher pitch noise/softer surfaces = lower pitch noises/edge to surface = chirping.
- Creak—(Like walking on an old wooden floor)  
Creak characteristics include firm contact/slow movement/twisting with a rotational movement/pitch dependent on materials/often brought on by activity.
- Rattle—(Like shaking a baby rattle)  
Rattle characteristics include the fast repeated contact/vibration or similar movement/loose parts/missing clip or fastener/incorrect clearance.
- Knock —(Like a knock on a door)  
Knock characteristics include hollow sounding/sometimes repeating/often brought on by driver action.
- Tick—(Like a clock second hand)  
Tick characteristics include gentle contacting of light materials/loose components/can be caused by driver action or road conditions.
- Thump—(Heavy, muffled knock noise)  
Thump characteristics include softer knock/dead sound often brought on by activity.
- Buzz—(Like a bumble bee)  
Buzz characteristics include high frequency rattle/firm contact.
- Often the degree of acceptable noise level will vary depending upon the person. A noise that you may judge as acceptable may be very irritating to the customer.
- Weather conditions, especially humidity and temperature, may have a great effect on noise level.

# SQUEAK AND RATTLE TROUBLE DIAGNOSES

## DUPLICATE THE NOISE AND TEST DRIVE

If possible, drive the vehicle with the customer until the noise is duplicated. Note any additional information on the Diagnostic Worksheet regarding the conditions or location of the noise. This information can be used to duplicate the same conditions when you confirm the repair.

If the noise can be duplicated easily during the test drive, to help identify the source of the noise, try to duplicate the noise with the vehicle stopped by doing one or all of the following:

- 1) Close a door.
  - 2) Tap or push/pull around the area where the noise appears to be coming from.
  - 3) Rev the engine.
  - 4) Use a floor jack to recreate vehicle "twist".
  - 5) At idle, apply engine load (electrical load, half-clutch on M/T model, drive position on A/T model).
  - 6) Raise the vehicle on a hoist and hit a tire with a rubber hammer.
- Drive the vehicle and attempt to duplicate the conditions the customer states exist when the noise occurs.
  - If it is difficult to duplicate the noise, drive the vehicle slowly on an undulating or rough road to stress the vehicle body.

## CHECK RELATED SERVICE BULLETINS

After verifying the customer concern or symptom, check ASIST for Technical Service Bulletins (TSBs) related to that concern or symptom.

If a TSB relates to the symptom, follow the procedure to repair the noise.

## LOCATE THE NOISE AND IDENTIFY THE ROOT CAUSE

1. Narrow down the noise to a general area. To help pinpoint the source of the noise, use a listening tool (Chassis Ear: J-39570, Engine Ear: J-39565 and mechanic's stethoscope).
2. Narrow down the noise to a more specific area and identify the cause of the noise by:
  - removing the components in the area that you suspect the noise is coming from. Do not use too much force when removing clips and fasteners, otherwise clips and fasteners can be broken or lost during the repair, resulting in the creation of new noise.
  - tapping or pushing/pulling the component that you suspect is causing the noise. Do not tap or push/pull the component with excessive force, otherwise the noise will be eliminated only temporarily.
  - feeling for a vibration with your hand by touching the component(s) that you suspect is (are) causing the noise.
  - placing a piece of paper between components that you suspect are causing the noise.
  - looking for loose components and contact marks.  
Refer to [GW-7, "Generic Squeak and Rattle Troubleshooting"](#) .

## REPAIR THE CAUSE

- If the cause is a loose component, tighten the component securely.
- If the cause is insufficient clearance between components:
  - separate components by repositioning or loosening and retightening the component, if possible.
  - insulate components with a suitable insulator such as urethane pads, foam blocks, felt cloth tape or urethane tape. A NISSAN Squeak and Rattle Kit (J-43980) is available through your authorized NISSAN Parts Department.

### CAUTION:

**Do not use excessive force as many components are constructed of plastic and may be damaged.**

**Always check with the Parts Department for the latest parts information.**

**The following materials are contained in the NISSAN Squeak and Rattle Kit (J-43980). Each item can be ordered separately as needed.**

**URETHANE PADS [1.5 mm (0.059 in) thick]**

**Insulates connectors, harness, etc.**

**76268-9E005: 100×135 mm (3.94×5.31 in)/76884-71L01: 60×85 mm (2.36×3.35 in)/76884-71L02: 15×25 mm (0.59×0.98 in)**

**INSULATOR (Foam blocks)**

**Insulates components from contact. Can be used to fill space behind a panel.**

**73982-9E000: 45 mm (1.77 in) thick, 50×50 mm (1.97×1.97 in)/73982-50Y00: 10 mm (0.39 in) thick, 50×50 mm (1.97×1.97 in)**

**INSULATOR (Light foam block)**

# SQUEAK AND RATTLE TROUBLE DIAGNOSES

**80845-71L00: 30 mm (1.18 in) thick, 30×50 mm (1.18×1.97 in)**

## FELT CLOTH TAPE

Used to insulate where movement does not occur. Ideal for instrument panel applications.

**68370-4B000: 15×25 mm (0.59×0.98 in) pad/68239-13E00: 5 mm (0.20 in) wide tape roll.** The following materials not found in the kit can also be used to repair squeaks and rattles.

## UHMW (TEFLON) TAPE

Insulates where slight movement is present. Ideal for instrument panel applications.

## SILICONE GREASE

Used instead of UHMW tape that will be visible or not fit.

**Note: Will only last a few months.**

## SILICONE SPRAY

Use when grease cannot be applied.

## DUCT TAPE

Use to eliminate movement.

## CONFIRM THE REPAIR

Confirm that the cause of a noise is repaired by test driving the vehicle. Operate the vehicle under the same conditions as when the noise originally occurred. Refer to the notes on the Diagnostic Worksheet.

## Generic Squeak and Rattle Troubleshooting

EIS009E0

Refer to Table of Contents for specific component removal and installation information.

## INSTRUMENT PANEL

Most incidents are caused by contact and movement between:

1. The cluster lid A and instrument panel
2. Acrylic lens and combination meter housing
3. Instrument panel to front pillar garnish
4. Instrument panel to windshield
5. Instrument panel mounting pins
6. Wiring harnesses behind the combination meter
7. A/C defroster duct and duct joint

These incidents can usually be located by tapping or moving the components to duplicate the noise or by pressing on the components while driving to stop the noise. Most of these incidents can be repaired by applying felt cloth tape or silicone spray (in hard to reach areas). Urethane pads can be used to insulate wiring harness.

### CAUTION:

**Do not use silicone spray to isolate a squeak or rattle. If you saturate the area with silicone, you will not be able to recheck the repair.**

## CENTER CONSOLE

Components to pay attention to include:

1. Shifter assembly cover to finisher
2. A/C control unit and cluster lid C
3. Wiring harnesses behind audio and A/C control unit

The instrument panel repair and isolation procedures also apply to the center console.

## DOORS

Pay attention to the:

1. Finisher and inner panel making a slapping noise
2. Inside handle escutcheon to door finisher
3. Wiring harnesses tapping
4. Door striker out of alignment causing a popping noise on starts and stops

Tapping or moving the components or pressing on them while driving to duplicate the conditions can isolate many of these incidents. You can usually insulate the areas with felt cloth tape or insulator foam blocks from the NISSAN Squeak and Rattle Kit (J-43980) to repair the noise.

# SQUEAK AND RATTLE TROUBLE DIAGNOSES

---

## TRUNK

Trunk noises are often caused by a loose jack or loose items put into the trunk by the owner. In addition look for:

1. Trunk lid bumpers out of adjustment
2. Trunk lid striker out of adjustment
3. The trunk lid torsion bars knocking together
4. A loose license plate or bracket

Most of these incidents can be repaired by adjusting, securing or insulating the item(s) or component(s) causing the noise.

## SUNROOF/HEADLINING

Noises in the sunroof/headlining area can often be traced to one of the following:

1. Sunroof lid, rail, linkage or seals making a rattle or light knocking noise
2. Sun visor shaft shaking in the holder
3. Front or rear windshield touching headliner and squeaking

Again, pressing on the components to stop the noise while duplicating the conditions can isolate most of these incidents. Repairs usually consist of insulating with felt cloth tape.

## OVERHEAD CONSOLE (FRONT AND REAR)

Overhead console noises are often caused by the console panel clips not being engaged correctly. Most of these incidents are repaired by pushing up on the console at the clip locations until the clips engage.

In addition look for:

1. Loose harness or harness connectors.
2. Front console map/reading lamp lense loose.
3. Loose screws at console attachment points.

## SEATS

When isolating seat noise it's important to note the position the seat is in and the load placed on the seat when the noise is present. These conditions should be duplicated when verifying and isolating the cause of the noise.

Cause of seat noise include:

1. Headrest rods and holder
2. A squeak between the seat pad cushion and frame
3. The rear seatback lock and bracket

These noises can be isolated by moving or pressing on the suspected components while duplicating the conditions under which the noise occurs. Most of these incidents can be repaired by repositioning the component or applying urethane tape to the contact area.

## UNDERHOOD

Some interior noise may be caused by components under the hood or on the engine wall. The noise is then transmitted into the passenger compartment.

Causes of transmitted underhood noise include:

1. Any component mounted to the engine wall
2. Components that pass through the engine wall
3. Engine wall mounts and connectors
4. Loose radiator mounting pins
5. Hood bumpers out of adjustment
6. Hood striker out of adjustment

These noises can be difficult to isolate since they cannot be reached from the interior of the vehicle. The best method is to secure, move or insulate one component at a time and test drive the vehicle. Also, engine RPM or load can be changed to isolate the noise. Repairs can usually be made by moving, adjusting, securing, or insulating the component causing the noise.



# SQUEAK AND RATTLE TROUBLE DIAGNOSES

EIS009E1

## Diagnostic Worksheet

Dear Customer:

We are concerned about your satisfaction with your vehicle. Repairing a squeak or rattle sometimes can be very difficult. To help us fix your vehicle right the first time, please take a moment to note the area of the vehicle where the squeak or rattle occurs and under what conditions. You may be asked to take a test drive with a service advisor or technician to ensure we confirm the noise you are hearing.

### SQUEAK & RATTLE DIAGNOSTIC WORKSHEET

#### I. WHERE DOES THE NOISE COME FROM? (circle the area of the vehicle)

The illustrations are for reference only, and may not reflect the actual configuration of your vehicle.

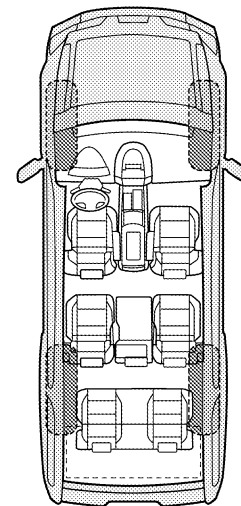
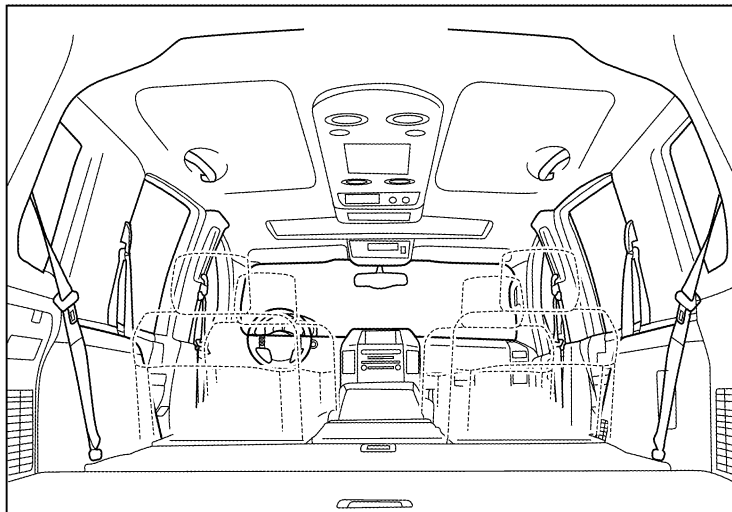
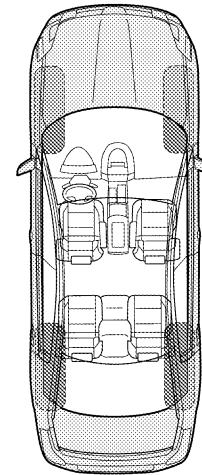
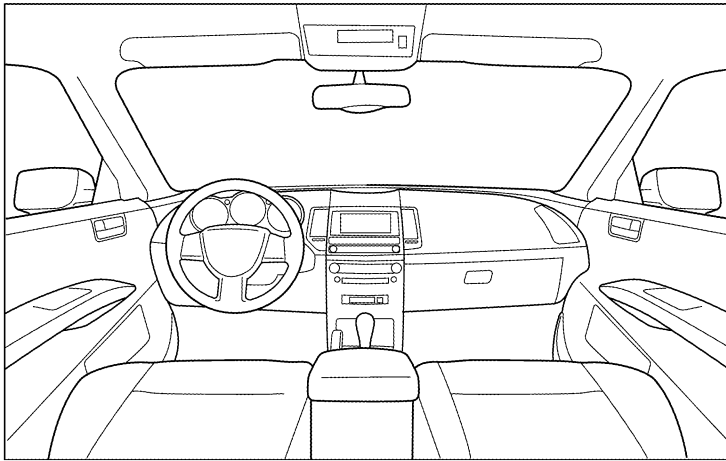

Continue to page 2 of the worksheet and briefly describe the location of the noise or rattle. In addition, please indicate the conditions which are present when the noise occurs.

A  
B  
C  
D  
E  
F  
G  
H  
GW  
J  
K  
L  
M

# SQUEAK AND RATTLE TROUBLE DIAGNOSES

## SQUEAK & RATTLE DIAGNOSTIC WORKSHEET - page 2

Briefly describe the location where the noise occurs:

---



---

### II. WHEN DOES IT OCCUR? (please check the boxes that apply)

- |   |  |
|---|--|
| <input type="checkbox"/> Anytime                      | <input type="checkbox"/> After sitting out in the rain |
| <input type="checkbox"/> 1st time in the morning      | <input type="checkbox"/> When it is raining or wet     |
| <input type="checkbox"/> Only when it is cold outside | <input type="checkbox"/> Dry or dusty conditions       |
| <input type="checkbox"/> Only when it is hot outside  | <input type="checkbox"/> Other:                        |

### III. WHEN DRIVING:

- Through driveways
- Over rough roads
- Over speed bumps
- Only about \_\_\_\_ mph
- On acceleration
- Coming to a stop
- On turns: left, right or either (circle)
- With passengers or cargo
- Other: \_\_\_\_\_
- After driving \_\_\_\_ miles or \_\_\_\_ minutes

### IV. WHAT TYPE OF NOISE

- Squeak (like tennis shoes on a clean floor)
- Creak (like walking on an old wooden floor)
- Rattle (like shaking a baby rattle)
- Knock (like a knock at the door)
- Tick (like a clock second hand)
- Thump (heavy muffled knock noise)
- Buzz (like a bumble bee)

## TO BE COMPLETED BY DEALERSHIP PERSONNEL

### Test Drive Notes:

---



---



---

	YES	NO	Initials of person performing
Vehicle test driven with customer	<input type="checkbox"/>	<input type="checkbox"/>	_____
- Noise verified on test drive	<input type="checkbox"/>	<input type="checkbox"/>	_____
- Noise source located and repaired	<input type="checkbox"/>	<input type="checkbox"/>	_____
- Follow up test drive performed to confirm repair	<input type="checkbox"/>	<input type="checkbox"/>	_____

LAI A0071E

# WINDSHIELD GLASS

## WINDSHIELD GLASS

PFP:72712

### Removal and Installation

EIS0094D

SEC. 720

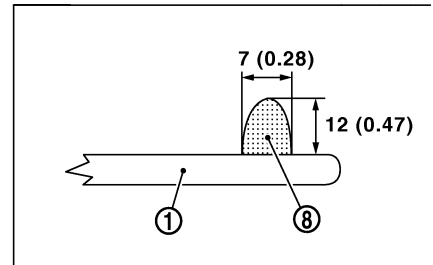
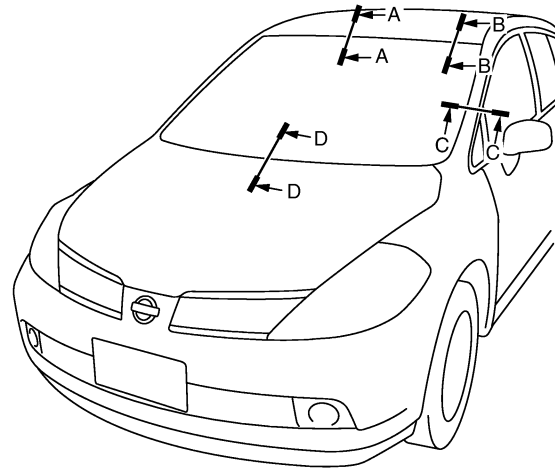
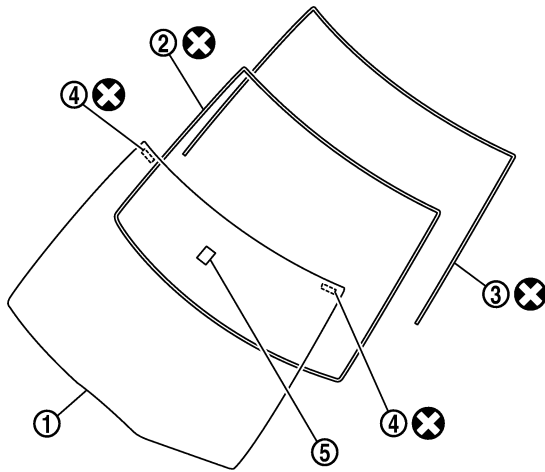

mm (in)

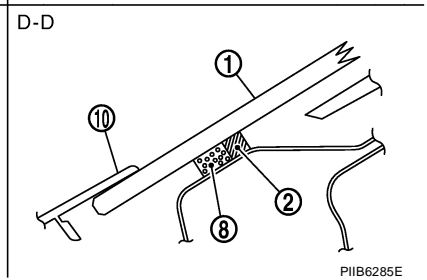
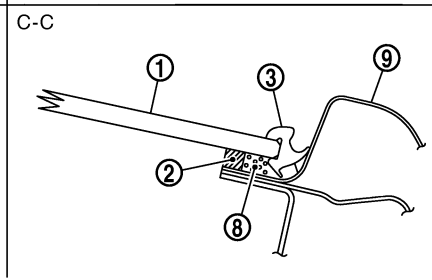
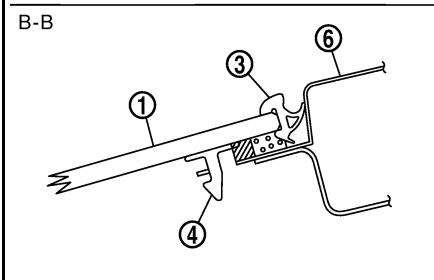
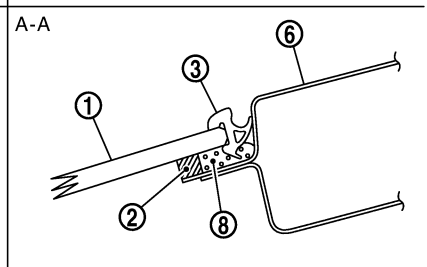
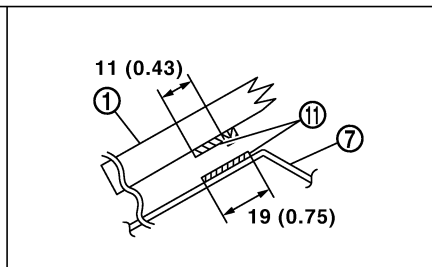
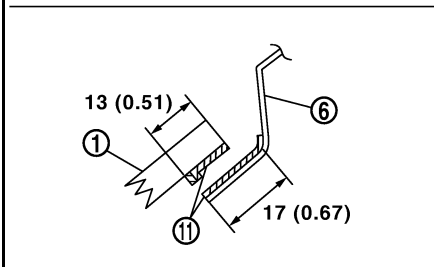

PIIB6285E

- |                              |                |                             |
|------------------------------|----------------|-----------------------------|
| 1. Windshield glass assembly | 2. Dam sealant | 3. Windshield molding       |
| 4. Spacer                    | 5. Mirror base | 6. Roof panel outer         |
| 7. Cowl top front            | 8. Adhesive    | 9. Front pillar outer panel |
| 10. Cowl top cover           | 11. Primer     |                             |

### REMOVAL

- Partially remove the headlining (front edge). Refer to [EI-39, "HEADLINING"](#) .
- Remove the front wiper arms. Refer to [WW-24, "Removal and Installation of Front Wiper Arms"](#) .
- Remove the cowl top cover. Refer to [EI-20, "COWL TOP"](#) .
- Disconnect the harness connector of wiper deicer.
- Apply protective tape around the windshield glass to protect the painted surface from damage.

A  
B  
C  
D  
E  
F  
G  
H  
J  
K  
L  
M

GW

# WINDSHIELD GLASS

After removing windshield upper molding, remove glass using piano wire or power cutting tool (A) and an inflatable pump bag (B).

- If a windshield glass is to be reused, mark the body and the glass with mating marks.

## WARNING:

When cutting the glass from the vehicle, always wear safety glasses and heavy gloves to help prevent glass splinters from entering your eyes or cutting your hands.

## CAUTION:

- When a windshield glass is to be reused, do not use a cutting knife or power cutting tool.
- Be careful not to scratch the glass when removing.
- Do not set or stand the glass on its edge. Small chips may develop into cracks.

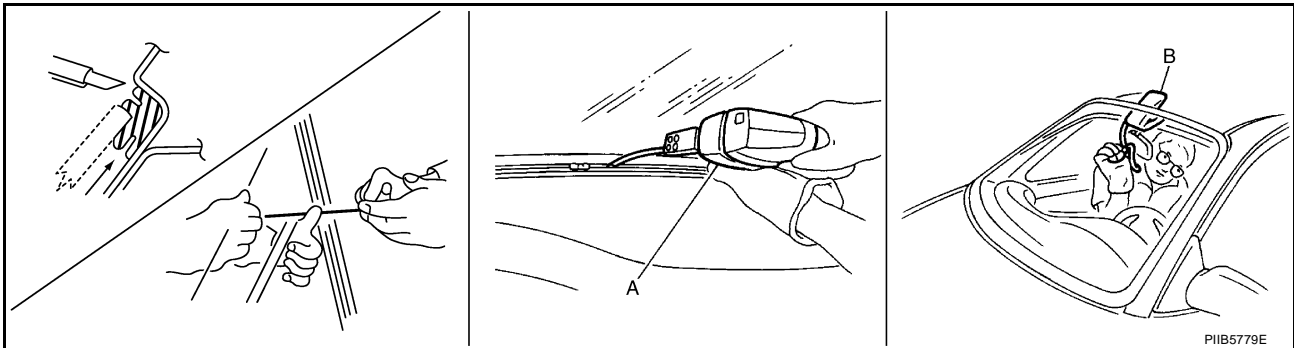

## INSTALLATION

- Use a genuine NISSAN Urethane Adhesive Kit (if available) or equivalent and follow the instructions furnished with it.
- While the urethane adhesive is curing, open a door window. This will prevent the glass from being forced out by passenger room air pressure when a door is closed.
- The molding must be installed securely so that it is in position and leaves no gap.
- Inform the customer that the vehicle should remain stationary until the urethane adhesive has completely cured (preferably 24 hours). Curing time varies with temperature and humidity.

## WARNING:

- Keep heat and open flames away as primers and adhesive are flammable.
- The materials contained in the kit are harmful if swallowed, and may irritate skin and eyes. Avoid contact with the skin and eyes.
- Use in an open, well ventilated location. Avoid breathing the vapors. They can be harmful if inhaled. If affected by vapor inhalation, immediately move to an area with fresh air.
- Driving the vehicle before the urethane adhesive has completely cured may affect the performance of the windshield in case of an accident.

## CAUTION:

- Do not use an adhesive which is past its usable term. Shelf life of the adhesive is limited to six months after the date of manufacture. Carefully adhere to the expiration or manufacture date printed on the box.
- Keep primers and adhesive in a cool, dry place. Ideally, they should be stored in a refrigerator.
- Do not leave primers or adhesive cartridge unattended with their caps open or off.
- The vehicle should not be driven for at least 24 hours or until the urethane adhesive has completely cured. Curing time varies depending on temperature and humidities. The curing time will increase under lower temperatures and lower humidities.

## Repairing Water Leaks

Leaks can be repaired without removing and reinstalling glass.

If water is leaking between the urethane adhesive material and body or glass, determine the extent of leakage.

This can be done by applying water to the windshield area while pushing glass outward.

To stop the leak, apply primer (if necessary) and then urethane adhesive to the leak point.

# OPERA WINDOW GLASS

PFP:76820

EIS0094E

## OPERA WINDOW GLASS

### Removal and Installation

SEC. 830

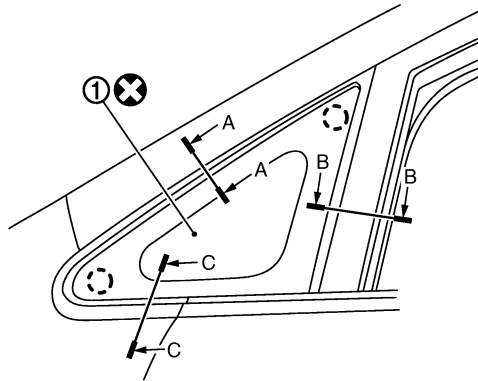

mm (in)

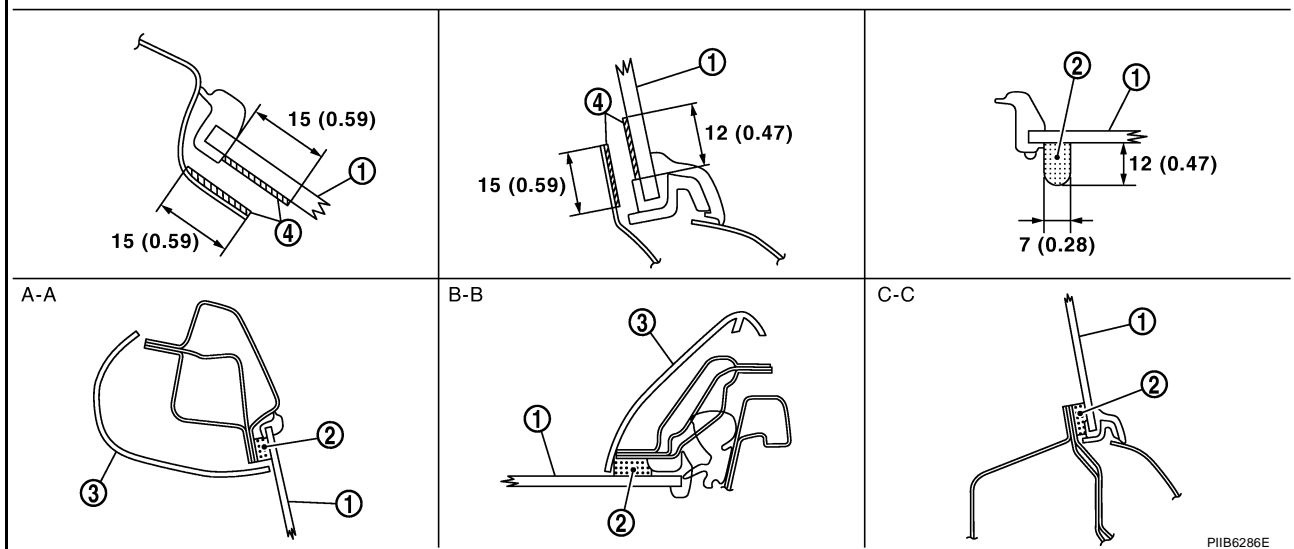

1. Opera window glass  
4. Primer

2. Adhesive

3. Front pillar garnish

### REMOVAL

1. Remove the front pillar garnish. Refer to [EI-33, "FRONT PILLAR GARNISH"](#).
2. Remove the instrument side panel. Refer to [IP-10, "INSTRUMENT PANEL ASSEMBLY"](#).
3. Apply protective tape around the opera window glass to protect the painted surface from damage.
  - If a opera window glass is to be reused, mark the body and the glass with mating marks.
4. Remove the opera window glass using piano wire or power cutting tool and inflatable pump bag.

### WARNING:

When cutting the glass from the vehicle, always wear safety glasses and heavy gloves to help prevent glass splinters from entering your eyes or cutting your hands.

### CAUTION:

- When a opera window glass is to be reused, do not use a cutting knife or power cutting tool.
- Be careful not to scratch the glass when removing.
- Do not set or stand the glass on its edge. Small chips may develop into cracks.
- Clips are molded to the side window glass. Replace the clips with new ones if they are damaged when removing the side window glass.

### INSTALLATION

- Use a genuine NISSAN Urethane Adhesive Kit (if available) or equivalent and follow the instructions furnished with it.

A  
B  
C  
D  
E  
F  
G  
H  
J  
K  
L  
M

GW

## OPERA WINDOW GLASS

---

- While the urethane adhesive is curing, open a door window. This will prevent the glass from being forced out by passenger room air pressure when a door is closed.
- The opera window glass must be installed securely so that the molding around glass is in position and leaves no gap.
- Inform the customer that the vehicle should remain stationary until the urethane adhesive has completely cured (preferably 24 hours). Curing time varies with temperature and humidity.

### **WARNING:**

- **Keep heat and open flames away as primers and adhesive are flammable.**
- **The materials contained in the kit are harmful if swallowed, and may irritate skin and eyes. Avoid contact with the skin and eyes.**
- **Use in an open, well ventilated location. Avoid breathing the vapors. They can be harmful if inhaled. If affected by vapor inhalation, immediately move to an area with fresh air.**
- **Driving the vehicle before the urethane adhesive has completely cured may affect the performance of the side window in case of an accident.**

### **CAUTION:**

- **Do not use an adhesive which is past its usable term. Shelf life of the adhesive is limited to six months after the date of manufacture. Carefully adhere to the expiration or manufacture date printed on the box.**
- **Keep primers and adhesive in a cool, dry place. Ideally, they should be stored in a refrigerator.**
- **Do not leave primers or adhesive cartridge unattended with their caps open or off.**
- **The vehicle should not be driven for at least 24 hours or until the urethane adhesive has completely cured. Curing time varies depending on temperature and humidities. The curing time will increase under lower temperature and lower humidity.**

### **Repairing Water Leaks**

Leaks can be repaired without removing and reinstalling glass.

If water is leaking between the urethane adhesive material and body or glass, determine the extent of leakage. This can be done by applying water to the side window area while pushing glass outward. To stop the leak, apply primer (if necessary) and then urethane adhesive to the leak point.

# REAR WINDOW GLASS AND MOLDING

## REAR WINDOW GLASS AND MOLDING

PF7:79712

### Removal and Installation

EIS0094F

SEC. 900

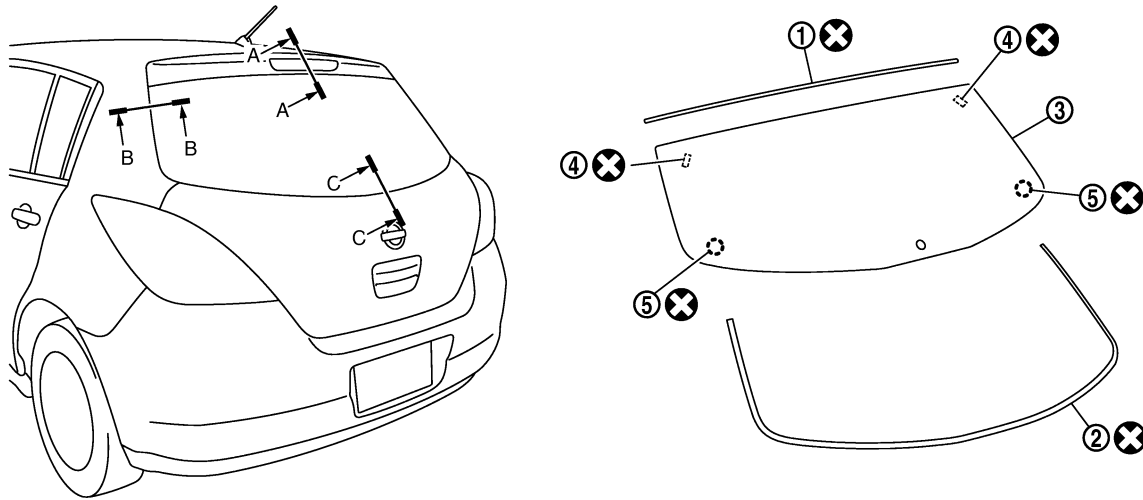

mm (in)

A-A

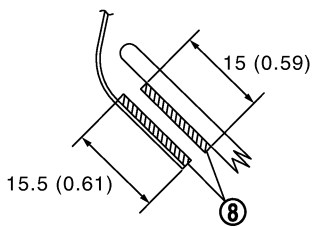

B-B

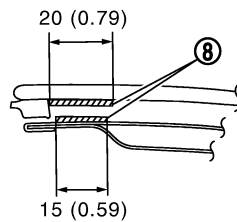

C-C

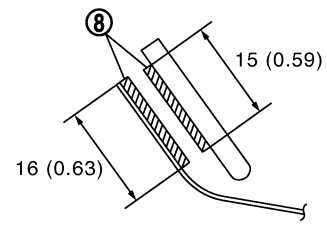

A-A

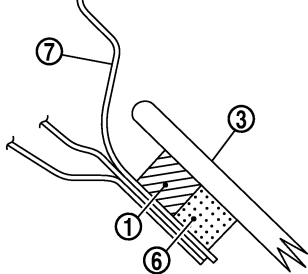

B-B

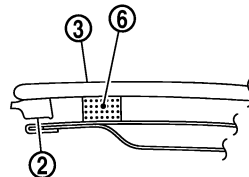

C-C

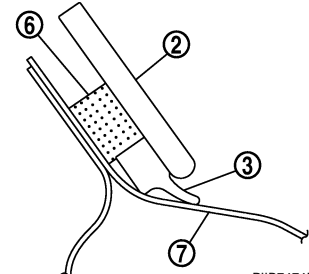

PIIB7474E

- |                          |                                     |                           |
|--------------------------|-------------------------------------|---------------------------|
| 1. Dam rubber            | 2. Back door window molding (Lower) | 3. Back door window glass |
| 4. Clip (Upper)          | 5. Clip (Lower)                     | 6. Adhesive               |
| 7. Back door outer panel | 8. Primer                           |                           |

### REMOVAL

1. Remove the rear wiper arm and motor. Refer to [WW-40, "Removal and Installation"](#) .
2. Remove the connectors and grounds for the rear window defogger.

A  
B  
C  
D  
E  
F  
G  
H  
J  
K  
L  
M

GW

## REAR WINDOW GLASS AND MOLDING

- Remove glass using piano wire or power cutting tool and an inflatable pump bag.
- If the rear window glass is to be reused, mark the body and the glass with mating marks.

### **WARNING:**

When cutting the glass from the vehicle, always wear safety glasses and heavy gloves to help prevent glass splinters from entering your eyes or cutting your hands.

### **CAUTION:**

- When a windshield glass is to be reused, do not use a cutting knife or power cutting tool.
- Be careful not to scratch the glass when removing.
- Do not set or stand the glass on its edge. Small chips may develop into cracks.

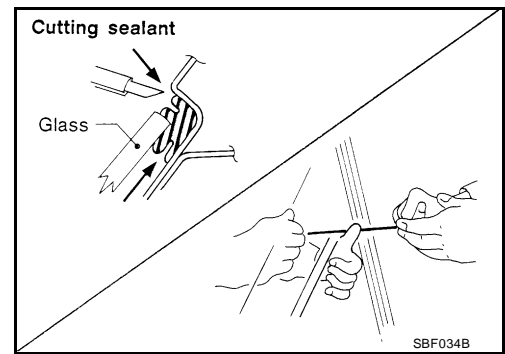

## INSTALLATION

Installation is in the reverse order of removal.

- Use a genuine NISSAN Urethane Adhesive Kit (if available) or equivalent and follow the instructions furnished with it.
- While the urethane adhesive is curing, open a door window. This will prevent the glass from being forced out by passenger compartment air pressure when a door is closed.
- The molding must be installed securely so that it is in position and leaves no gap.
- Check gap along bottom to confirm that glass does not contact sheet metal.
- Inform the customer that the vehicle should remain stationary until the urethane adhesive has completely cured (preferably 24 hours). Curing time varies with temperature and humidity.

### **WARNING:**

- Keep heat and open flames away as primers and adhesive are flammable.
- The materials contained in the kit are harmful if swallowed, and may irritate skin and eyes. Avoid contact with the skin and eyes.
- Use in an open, well ventilated location. Avoid breathing the vapors. They can be harmful if inhaled. If affected by vapor inhalation, immediately move to an area with fresh air.
- Driving the vehicle before the urethane adhesive has completely cured may affect the performance of the windshield in case of an accident.

### **CAUTION:**

- Do not use an adhesive which is past its usable term. Shelf life of this product is limited to six months after the date of manufacture. Carefully adhere to the expiration or manufacture date printed on the box.
- Keep primers and adhesive in a cool, dry place. Ideally, they should be stored in a refrigerator.
- Do not leave primers or adhesive cartridge unattended with their caps open or off.
- The vehicle should not be driven for at least 24 hours or until the urethane adhesive has completely cured. Curing time varies depending on temperature and humidity. The curing time will increase under lower temperatures and lower humidities.

## Repairing Water leaks for Rear Window Glass

Leaks can be repaired without removing or reinstalling glass.

If water is leaking between urethane adhesive material and body or glass, determine the extent of leakage.

This can be done by applying water to the rear window area while pushing glass outward.

To stop leak, apply primer (if necessary) and then urethane adhesive to the leak point.



## POWER WINDOW SYSTEM

PFPP:25401

### Component Parts and Harness Connector Location

E/IS00992

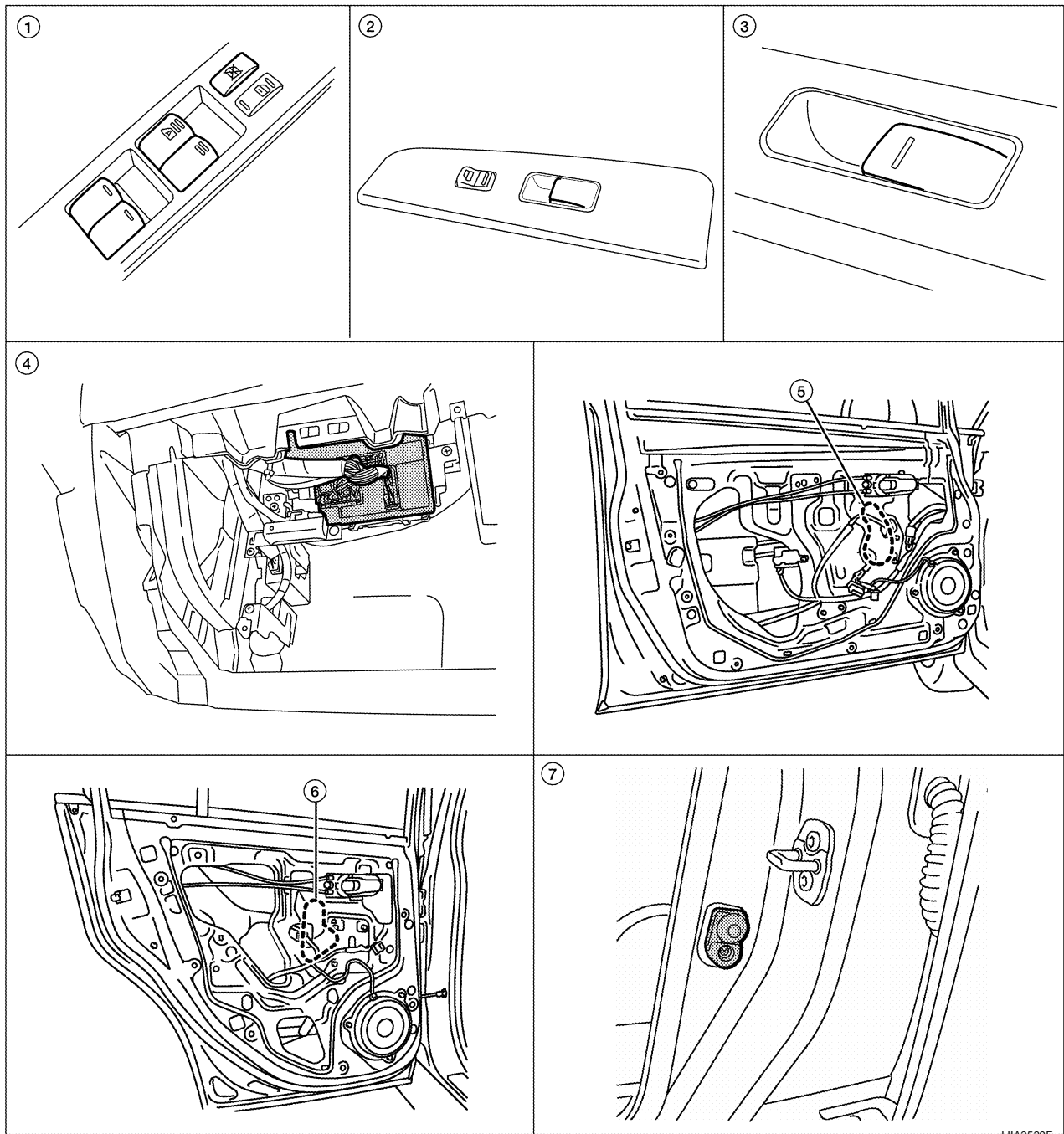

- |   |   |  |
|---|---|--|
| 1. Main power window and door lock/unlock switch D7, D8 | 2. Power window and door lock/unlock switch RH D105 | 3. Rear power window switch LH D203, RH D303 |
| 4. BCM M18, M19, M20 (view with glove box removed)      | 5. Front power window motor LH D9, RH D104          | 6. Rear power window motor LH D204, RH D304  |
| 7. Front door switch LH B8, RH B108                     |   |  |

### System Description

E/IS00993

Power is supplied at all times

- through 40A fusible link (letter **g**, located in the fuse and fusible link box)
- to BCM terminal 70.

With ignition switch in ON or START position, power is supplied

A  
B  
C  
D  
E  
F  
G  
H  
GW  
J  
K  
L  
M

# POWER WINDOW SYSTEM

---

- through 10A fuse [No. 6, located in the fuse block (J/B)]
- to BCM terminal 38
- through BCM terminal 68
- to main power window and door lock/unlock switch terminal 10
- to power window and door lock/unlock switch RH terminal 8 and
- to rear power window switches LH and RH terminal 1.

Ground is supplied

- to BCM terminal 67
- to main power window and door lock/unlock switch terminal 17 and
- to power window and door lock/unlock switch RH terminal 3
- through body grounds M57 and M61.

With ignition switch in ACC or ON position, power is supplied

- through 10A fuse [No. 20, located in the fuse block (J/B)]
- to BCM terminal 11.

## MANUAL OPERATION

### Front Door LH

#### WINDOW UP

When the front LH switch in the main power window and door lock/unlock switch is pressed in the up position, power is supplied

- through main power window and door lock/unlock switch terminal 8
- to front power window motor LH terminal 2.

Ground is supplied

- through main power window and door lock/unlock switch terminal 11
- to front power window motor LH terminal 3.

Then, the motor raises the window until the switch is released.

#### WINDOW DOWN

When the front LH switch in the main power window and door lock/unlock switch is pressed in the down position, power is supplied

- through main power window and door lock/unlock switch terminal 11
- to front power window motor LH terminal 3.

Ground is supplied

- through main power window and door lock/unlock switch terminal 8
- to front power window motor LH terminal 2.

Then, the motor lowers the window until the switch is released.

### Front Door RH

#### POWER WINDOW AND DOOR LOCK/UNLOCK SWITCH RH OPERATION

##### WINDOW UP

When the power window and door lock/unlock switch RH is pressed in the up position, power is supplied

- through power window and door lock/unlock switch RH terminal 7
- to front power window motor RH terminal 2.

Ground is supplied

- through power window and door lock/unlock switch RH terminal 6
- to front power window motor RH terminal 1.

Then, the motor raises the window until the switch is released.

##### WINDOW DOWN

When the power window and door lock/unlock switch RH is pressed in the down position, power is supplied

- through power window and door lock/unlock switch RH terminal 6
- to front power window motor RH terminal 1.

Ground is supplied

- through power window and door lock/unlock switch RH terminal 7

# POWER WINDOW SYSTEM

- to front power window motor RH terminal 2.

Then, the motor lowers the window until the switch is released.

## MAIN POWER WINDOW AND DOOR LOCK/UNLOCK SWITCH OPERATION

### WINDOW UP

When the main power window and door lock/unlock switch (front RH) is pressed in the up position, power is supplied

- through main power window and door lock/unlock switch terminal 16
- to power window and door lock/unlock switch RH terminal 12
- through power window and door lock/unlock switch RH terminal 7
- to front power window motor RH terminal 2.

Ground is supplied

- through main power window and door lock/unlock switch terminal 12
- to power window and door lock/unlock switch RH terminal 11
- through power window and door lock/unlock switch LH terminal 6
- to front power window motor RH terminal 1.

Then, the motor raises the window until the switch is released.

### WINDOW DOWN

When the main power window and door lock/unlock switch (front RH) is pressed in the down position, power is supplied

- through main power window and door lock/unlock switch terminal 12
- to power window and door lock/unlock switch LH terminal 11
- through power window and door lock/unlock switch LH terminal 6
- to front power window motor RH terminal 1.

Ground is supplied

- through main power window and door lock/unlock switch terminal 16
- to power window and door lock/unlock switch RH terminal 12
- through power window and door lock/unlock switch LH terminal 7
- to front power window motor RH terminal 2.

Then, the motor lowers the window until the switch is released.

## Rear Door (LH or RH)

### REAR POWER WINDOW SWITCH LH OR RH OPERATION

#### WINDOW UP

When the rear power window switch LH or RH is pressed in the up position, power is supplied

- through rear power window switch LH or RH terminal 5
- to rear power window motor LH or RH terminal 2.

Ground is supplied

- through rear power window switch LH or RH terminal 4
- to rear power window motor LH or RH terminal 1.

Then, the motor raises the window until the switch is released.

#### WINDOW DOWN

When the rear power window switch LH or RH is pressed in the down position, power is supplied

- through rear power window switch LH or RH terminal 4
- to rear power window motor LH or RH terminal 1.

Ground is supplied

- through rear power window switch LH or RH terminal 5
- to rear power window motor LH or RH terminal 2.

Then, the motor lowers the window until the switch is released.

## MAIN POWER WINDOW AND DOOR LOCK/UNLOCK SWITCH OPERATION

### WINDOW UP

When the main power window and door lock/unlock switch (rear LH) is pressed in the up position, power is supplied

A  
B  
C  
D  
E  
F  
G  
H  
J  
K  
L  
M

GW

# POWER WINDOW SYSTEM

---

- through main power window and door lock/unlock switch terminal 1
- to rear power window switch LH terminal 2
- through rear power window switch LH terminal 5
- to rear power window motor LH terminal 2.

Ground is supplied

- through main power window and door lock/unlock switch terminal 3
- to rear power window switch LH terminal 3
- through rear power window switch LH terminal 4
- to rear power window motor LH terminal 1.

Then, the motor raises the window until the switch is released.

When the main power window and door lock/unlock switch (rear RH) is pressed in the up position, power is supplied

- through main power window and door lock/unlock switch terminal 7
- to rear power window switch RH terminal 2
- through rear power window switch RH terminal 5
- to rear power window motor RH terminal 2.

Ground is supplied

- through main power window and door lock/unlock switch terminal 5
- through rear power window switch RH terminal 3
- to rear power window switch RH terminal 4
- to rear power window motor RH terminal 1.

Then, the motor raises the window until the switch is released.

## **WINDOW DOWN**

When the main power window and door lock/unlock switch (rear LH) is pressed in the down position, power is supplied

- through main power window and door lock/unlock switch terminal 3
- to rear power window switch LH terminal 3
- through rear power window switch LH terminal 4
- to rear power window motor LH terminal 1.

Ground is supplied

- through main power window and door lock/unlock switch terminal 1
- to rear power window switch LH terminal 2
- through rear power window switch LH terminal 5
- to rear power window motor LH terminal 2.

Then, the motor lowers the window until the switch is released.

When the main power window and door lock/unlock switch (rear RH) is pressed in the down position, power is supplied

- through main power window and door lock/unlock switch terminal 5
- to rear power window switch RH terminal 3
- through rear power window switch RH terminal 4
- to rear power window motor RH terminal 1.

Ground is supplied

- through main power window and door lock/unlock switch terminal 7
- to rear power window switch RH terminal 2
- through rear power window switch RH terminal 5
- to rear power window motor RH terminal 2.

Then, the motor lowers the window until the switch is released.

## **AUTO OPERATION**

The power window AUTO feature enables the driver to open the window without holding the window switch in the down position.

# POWER WINDOW SYSTEM

---

## POWER WINDOW LOCK

The power window lock is designed to lock operation of all windows except for front door window LH. When in the lock position, the power window lock disables power window and door lock/unlock switch RH and rear power window switch LH and RH by disconnecting switch ground signal. This prevents the power window motors from operating.

## RETAINED POWER OPERATION

When the ignition switch is turned to the OFF position from ON or START position, power is supplied for 45 seconds

- through BCM terminal 68
- to main power window and door lock/unlock switch terminal 10
- to power window and door lock/unlock switch RH terminal 8 and
- to rear power window switches LH and RH terminal 1.

When power and ground are supplied, the BCM continues to be energized, and the power window can be operated.

The retained power operation is canceled when the front LH or front RH door is opened.

Retained power operation period can be changed by CONSULT-II. Refer to [GW-29, "ACTIVE TEST"](#) .

## CAN Communication System Description

EIS00994

Refer to [LAN-4, "SYSTEM DESCRIPTION"](#) .

A  
B  
C  
D  
E  
F  
G  
H  
J  
K  
L  
M

GW

# POWER WINDOW SYSTEM

## Schematic

EIS00995

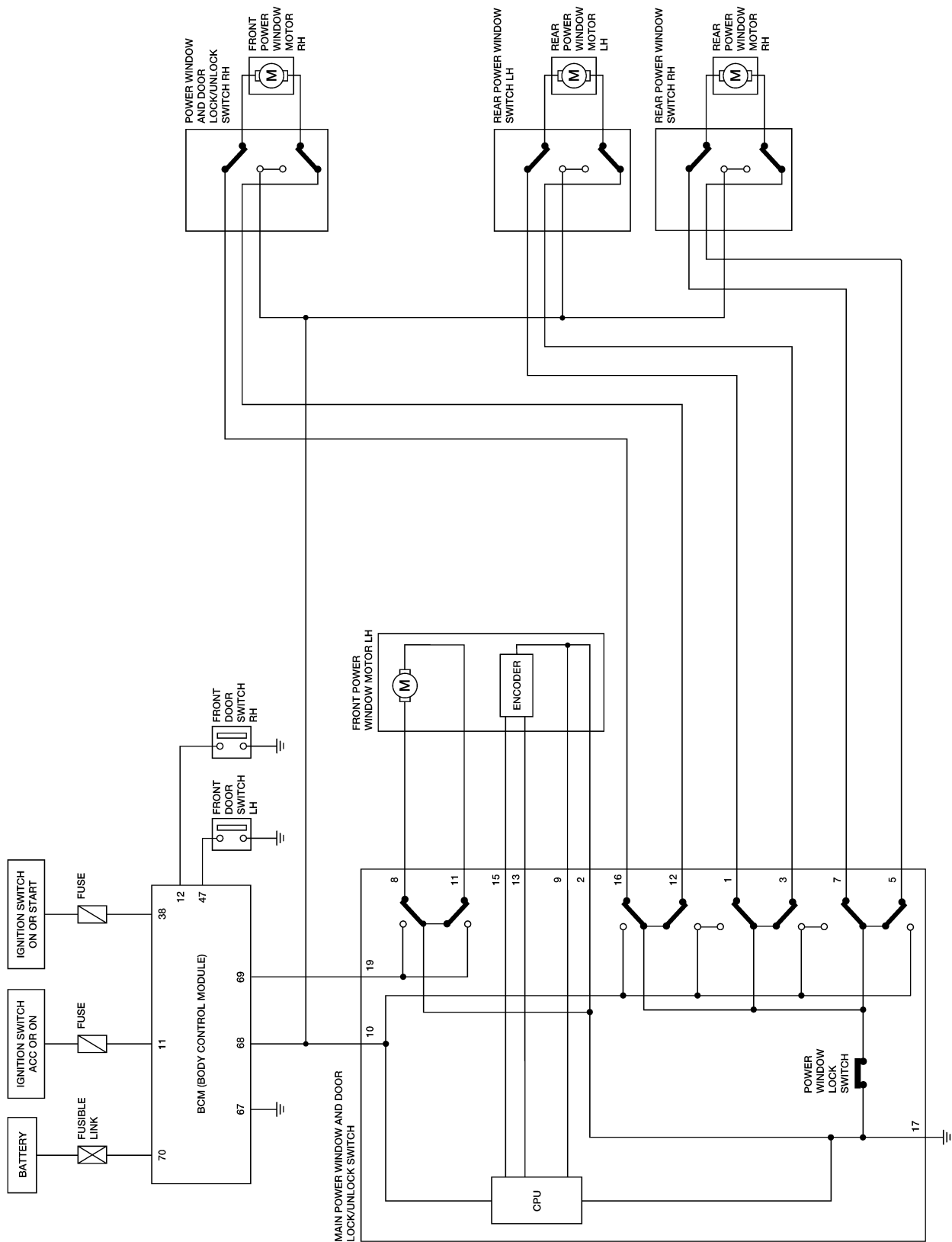

WIWA1977E



# POWER WINDOW SYSTEM

GW-WINDOW-02

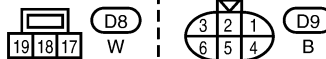
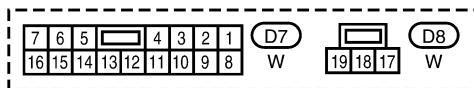
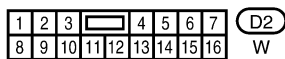
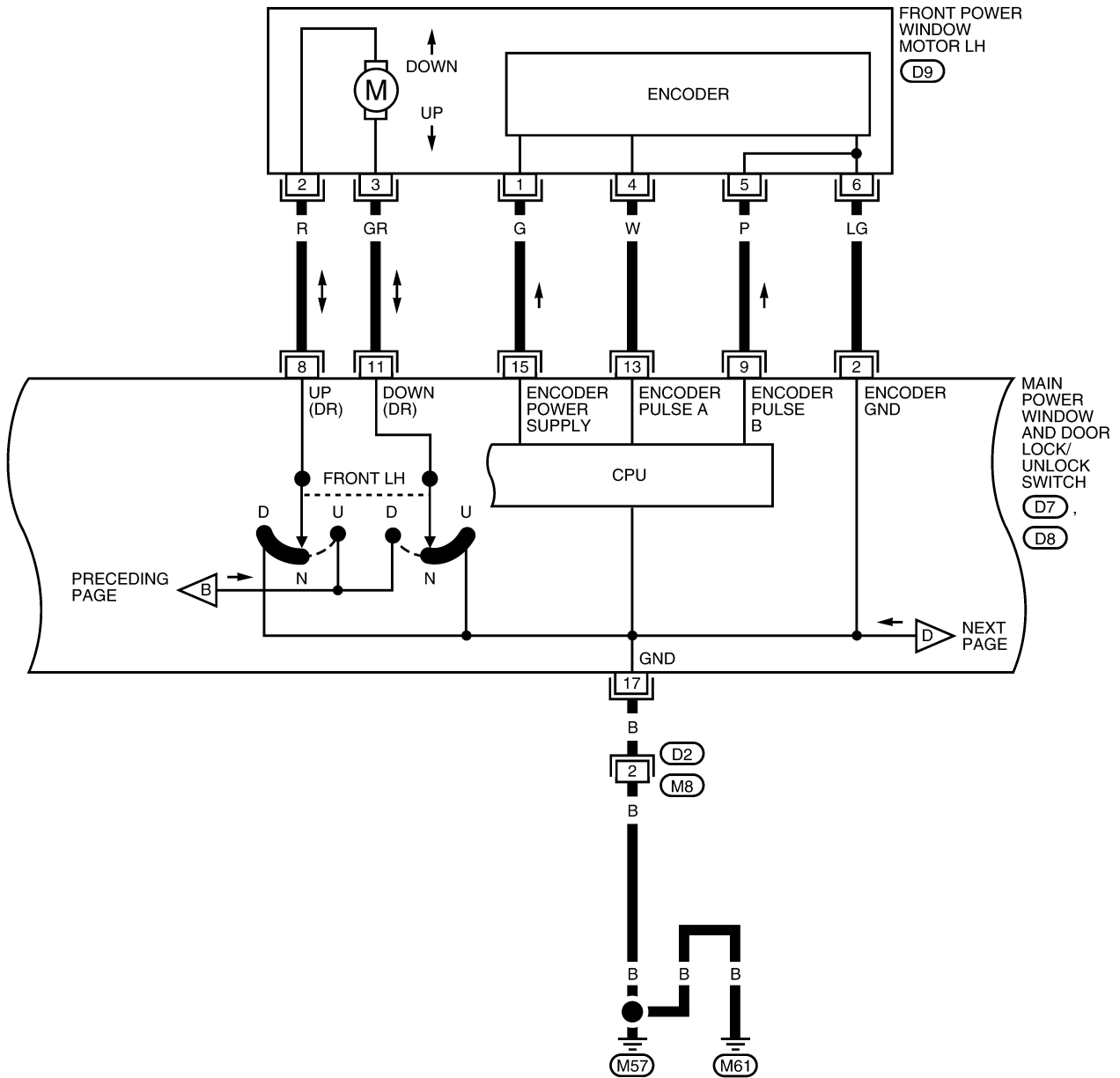

LIWA0556E



# POWER WINDOW SYSTEM

GW-WINDOW-03

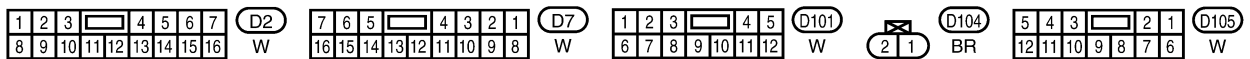
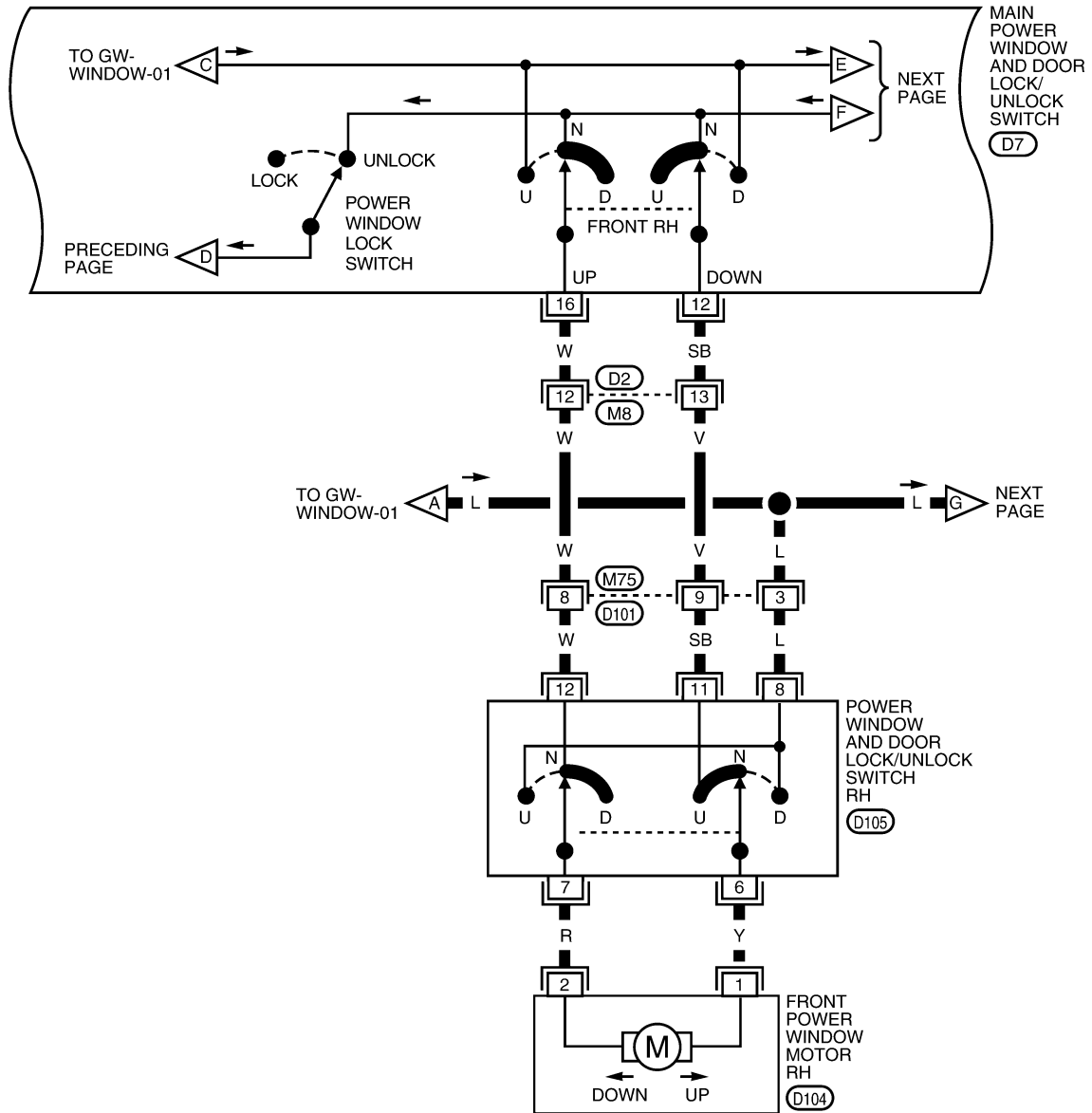

W1WA1979E

# POWER WINDOW SYSTEM

GW-WINDOW-04

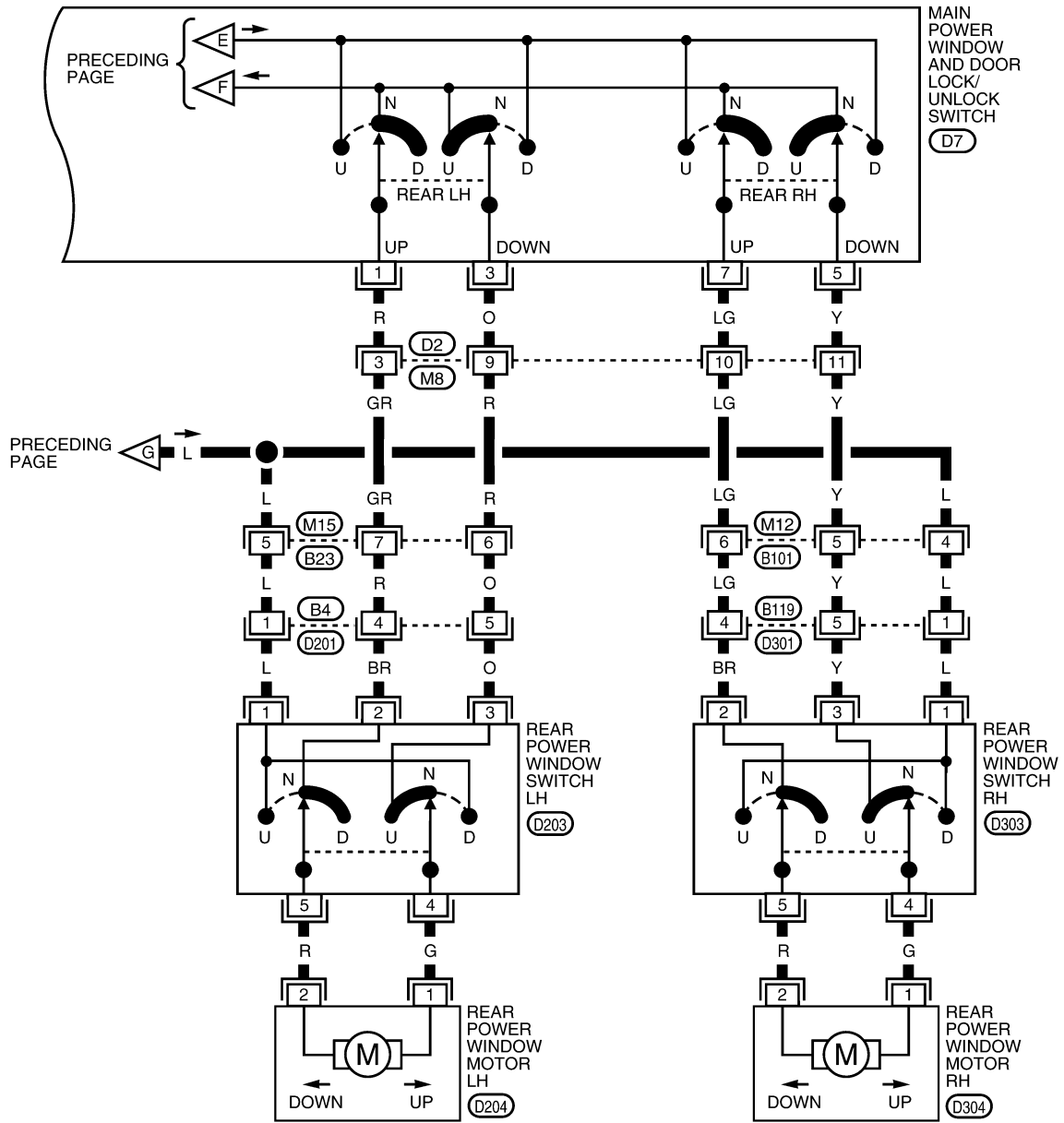

1	2	3	4	5	6	7		
8	9	10	11	12	13	14	15	16

(M12)	(M15)	(D2)
W	W	W

7	6	5	4	3	2	1		
16	15	14	13	12	11	10	9	8

1	2	3		
4	5	6	7	8

(D201)	(D301)
W	W

1	5	4	3	2
---	---	---	---	---

(D203)	(D303)
W	W

(D204)	(D304)
BR	BR

WIWA1980E

# POWER WINDOW SYSTEM

## Main Power Window and Door Lock/Unlock Switch Harness Connector Terminal Layout

EIS009CH

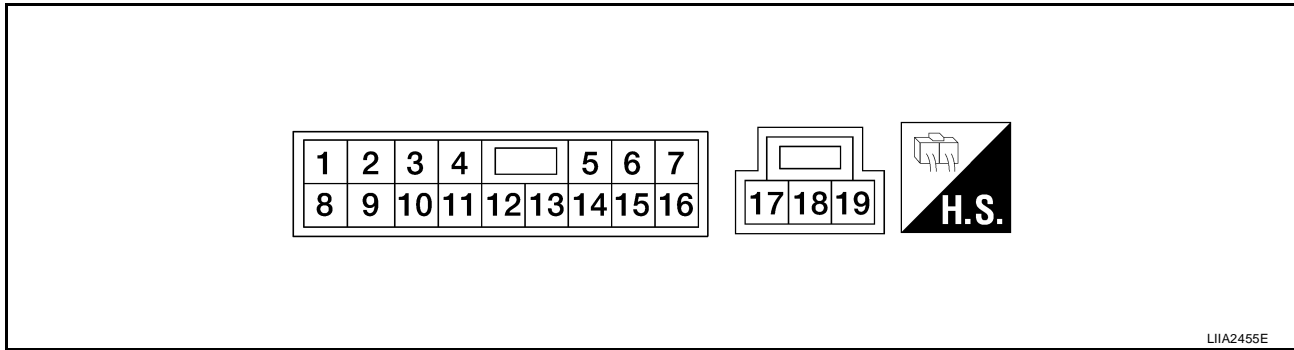

LIA2455E

## Terminal and Reference Value for Main Power Window and Door Lock/Unlock Switch

EIS00997

Terminal	Wire Color	Item	Condition	Voltage (V) (Approx.)
1	R	Rear power window LH UP signal	When rear LH switch in main power window and door lock/unlock switch is operated UP	Battery voltage
2	LG	Encoder ground	—	0
3	O	Rear power window LH DOWN signal	When rear LH switch in main power window and door lock/unlock switch is operated DOWN	Battery voltage
5	Y	Rear power window RH DOWN signal	When rear RH switch in main power window and door lock/unlock switch is operated DOWN	Battery voltage
7	LG	Rear power window RH UP signal	When rear RH switch in main power window and door lock/unlock switch is operated UP	Battery voltage
8	R	Front power window motor LH UP signal	When power window motor is operated UP	Battery voltage
9	P	Encoder pulse B signal	When power window switch operates	<p>OCC3383D</p>
10	L	RAP signal	When ignition switch ON	Battery voltage
			Within 45 seconds after ignition switch is turned to OFF	Battery voltage
			More than 45 seconds after ignition switch is turned to OFF	0
			When front door LH or RH open or power window timer operates	0
11	GR	Front power window motor LH DOWN signal	When power window motor is operated DOWN	Battery voltage
12	SB	Front power window motor RH DOWN signal	When power window motor is operated DOWN	Battery voltage

# POWER WINDOW SYSTEM

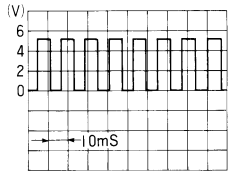
Terminal	Wire Color	Item	Condition	Voltage (V) (Approx.)
13	W	Encoder pulse A signal	When power window motor operates	
15	G	Encoder power supply	When ignition switch ON or power window timer operates	10
16	W	Front power window motor LH UP signal	When power window motor is operated UP	Battery voltage
17	B	Ground	—	0
19	P	Battery power supply	—	Battery voltage

## Terminal and Reference Value for BCM

EIS00998

Refer to [BCS-12, "Terminals and Reference Values for BCM"](#) .

## Work Flow

EIS00999

1. Check the symptom and customer's requests.
2. Understand the outline of system. Refer to [GW-17, "System Description"](#) .
3. According to the trouble diagnosis chart, repair or replace the cause of the malfunction. Refer to [GW-29, "Trouble Diagnoses Symptom Chart"](#) .
4. Does power window system operate normally? If Yes, GO TO 5, If No, GO TO 3.
5. Inspection End.

## CONSULT-II Function (BCM)

EIS0099A

CONSULT-II can display each diagnostic item using the diagnostic test modes shown following.

BCM diagnostic test item	Diagnostic mode	Content
Inspection by part	WORK SUPPORT	Supports inspections and adjustments. Commands are transmitted to the BCM for setting the status suitable for required operation, input/output signals are received from the BCM and received data is displayed.
	DATA MONITOR	Displays BCM input/output data in real time.
	ACTIVE TEST	Operation of electrical loads can be checked by sending drive signal to them.
	SELF-DIAG RESULTS	Displays BCM self-diagnosis results.
	CAN DIAG SUPPORT MNTR	The results of transmit/receive diagnosis of CAN communication can be read.
	ECU PART NUMBER	BCM part number can be read.
	CONFIGURATION	Performs BCM configuration read/write functions.

## CONSULT-II START PROCEDURE

Refer to [GI-38, "CONSULT-II Start Procedure"](#) .

# POWER WINDOW SYSTEM

## ACTIVE TEST

Test Item	Description
RETAINED PWR	<p>This test is able to supply RAP signal (power) from BCM (body control module) to power window system and power sunroof system (if equipped). Those systems can be operated when turning on "RETAINED PWR" on CONSULT-II screen even if the ignition switch is turned OFF.</p> <p><b>NOTE:</b> During this test, CONSULT-II can be operated with ignition switch in OFF position. "RETAINED PWR" should be turned "ON" or "OFF" on CONSULT-II screen when ignition switch is ON. Then turn ignition switch OFF to check retained power operation. CONSULT-II might be stuck if "RETAINED PWR" is turned "ON" or "OFF" on CONSULT-II screen when ignition switch is OFF.</p>

## WORK SUPPORT

Work item	Description
RETAINED PWR	<p>RAP signal's power supply period can be changed by mode setting. Selects RAP signal's power supply period between three steps</p> <ul style="list-style-type: none"> <li>● MODE1 (45 sec.)/MODE2 (OFF)/MODE3 (2 min.).</li> </ul>

## DATA MONITOR

Work item	Description
IGN ON SW	Indicates (ON/OFF) condition of ignition switch
DOOR SW-DR	Indicates (ON/OFF) condition of front door switch LH
DOOR SW-AS	Indicates (ON/OFF) condition of front door switch RH

## Trouble Diagnoses Symptom Chart

EIS0099B

Check that other systems using the signal of the following systems operate normally.

Symptom	Repair order	Refer to page
None of the power windows can be operated using any switch	1. BCM power supply and ground circuit check	<a href="#">BCS-16</a>
	2. Main power window and door lock/unlock power supply and ground circuit check	<a href="#">GW-30</a>
	3. Replace main power window and door lock/unlock switch	<a href="#">EI-27</a>
Front power window LH alone does not operate	1. Front power window motor LH circuit check	<a href="#">GW-32</a>
	2. Replace main power window and door lock/unlock switch	<a href="#">EI-27</a> , <a href="#">"FRONT DOOR"</a>
Front power window RH does not operate from power window and door lock/unlock switch RH only	1. Front power window RH circuit check (power window and door lock/unlock switch RH operation)	<a href="#">GW-33</a>
Front power window RH does not operate from main power window and door lock/unlock switch only	1. Replace main power window and door lock/unlock switch	<a href="#">EI-27</a>
Front power window RH does not operate from any switch	1. Front power window motor RH circuit check	<a href="#">GW-33</a>
Anti-pinch system does not operate normally (Front LH)	1. Door window sliding part malfunction ● A foreign material adheres to window glass or glass run rubber. ● Glass run rubber wear or deformation. ● Sash is tilted too much, or not enough.	—
	2. Encoder circuit check	<a href="#">GW-34</a>
Rear power window LH does not operate from rear power window switch LH only	1. Rear power window LH circuit check (rear power window switch LH operation)	<a href="#">GW-38</a>
Rear power window LH does not operate from main power window and door lock/unlock switch only	1. Replace main power window and door lock/unlock switch	<a href="#">EI-27</a>
Rear power window LH does not operate from any switch	1. Rear power window motor LH circuit check	<a href="#">GW-39</a>

# POWER WINDOW SYSTEM

Symptom	Repair order	Refer to page
Rear power window RH does not operate from rear power window switch RH only	1. Rear power window RH circuit check (rear window switch RH operation)	<a href="#">GW-39</a>
Rear power window RH does not operate from main power window and door lock/unlock switch only	1. Replace main power window and door lock/unlock switch	<a href="#">EI-27</a>
Rear power window RH does not operate from any switch	1. Rear power window motor RH circuit check	<a href="#">GW-41</a>
Power window retained power operation does not operate properly	1. Check the retained power operation mode setting.	<a href="#">GW-29</a>
	2. Door switch check	<a href="#">GW-37</a>
	3. Replace BCM.	<a href="#">BCS-25</a>

## BCM Power Supply and Ground Circuit Check

EIS0099C

Refer to [BCS-16, "BCM Power Supply and Ground Circuit Check"](#) .

## Main Power Window and Door Lock/Unlock Switch Power Supply and Ground Circuit Check

EIS0099D

### 1. CHECK POWER SUPPLY CIRCUIT

- Turn ignition switch ON.
- Check voltage between main power window and door lock/unlock switch connector D7 terminal 10, D8 terminal 19 and ground.

**10 - Ground : Battery voltage**  
**19 - Ground : Battery voltage**

OK or NG

- OK >> GO TO 2.  
 NG >> GO TO 3.

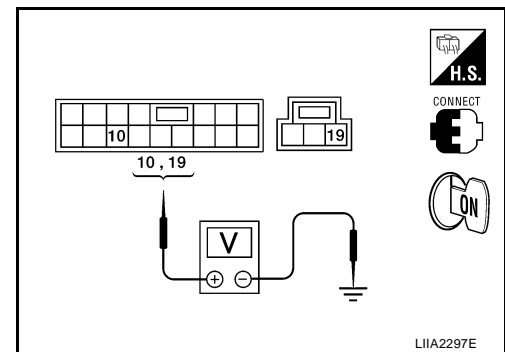

### 2. CHECK GROUND CIRCUIT

- Turn ignition switch OFF.
- Disconnect main power window and door lock/unlock switch.
- Check continuity between main power window and door lock/unlock switch connector D8 terminal 17 and ground.

**17 - Ground : Continuity should exist.**

OK or NG

- OK >> Power supply and ground circuit are OK.  
 NG >> Repair or replace harness.

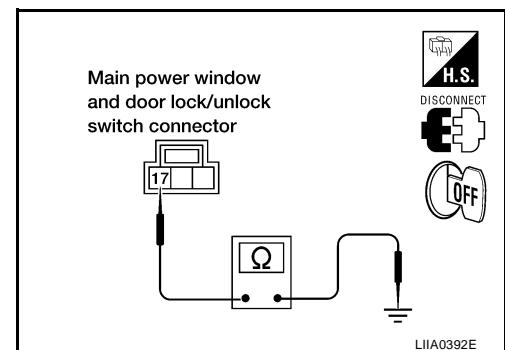

# POWER WINDOW SYSTEM

## 3. CHECK MAIN POWER WINDOW AND DOOR LOCK/UNLOCK SWITCH POWER SUPPLY CIRCUIT

1. Turn ignition switch OFF.
2. Disconnect BCM and main power window and door lock/unlock switch.
3. Check continuity between BCM connector and main power window and door lock/unlock switch connectors.

Connector	Terminal	Connector	Terminal	Continuity
A		B		
BCM: M20	68	Main power window and door lock/unlock switch: D7	10	Yes
	69	Main power window and door lock/unlock switch: D8	19	Yes

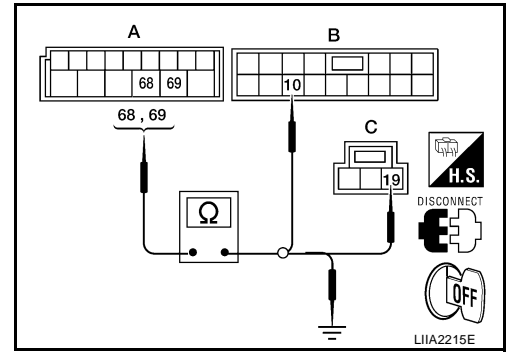

4. Check continuity between BCM and ground.

Connector	Terminal	Ground	Continuity
A			
BCM: M20	68	Ground	No
	69		No

OK or NG

- OK >> GO TO 4.  
 NG >> Repair or replace harness.

## 4. CHECK BCM OUTPUT SIGNAL

1. Connect BCM.
2. Turn ignition switch ON.
3. Check voltage between BCM connector M20 terminals 68, 69 and ground.

**68 - Ground : Battery voltage**  
**69 - Ground : Battery voltage**

OK or NG

- OK >> Check the condition of the harness and the connector.  
 NG >> Replace BCM. Refer to [BCS-25, "Removal and Installation of BCM"](#) .

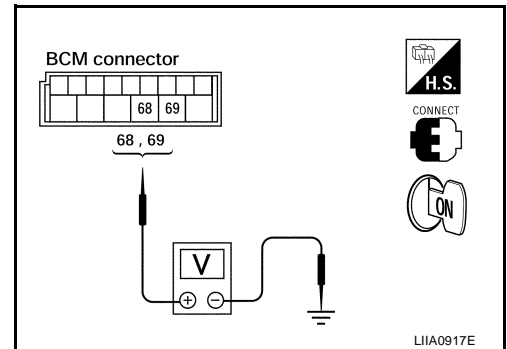

# POWER WINDOW SYSTEM

EIS0099E

## Front Power Window Motor LH Circuit Check

### 1. CHECK MAIN POWER WINDOW AND DOOR LOCK/UNLOCK SWITCH OUTPUT SIGNAL

1. Turn ignition switch OFF.
2. Check voltage between main power window and door lock/unlock switch connector D7 terminals 8, 11 and ground.

Connector	Terminals		Condition	Voltage (V) (Approx.)
	(+)	(-)		
D7	8	Ground	UP	Battery voltage
			DOWN	0
	11		UP	0
			DOWN	Battery voltage

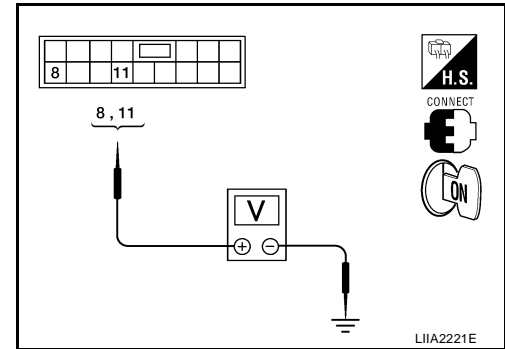

OK or NG

OK >> GO TO 2.

NG >> Replace main power window and door lock/unlock switch. Refer to [EI-27, "FRONT DOOR"](#).

### 2. CHECK POWER WINDOW MOTOR CIRCUIT

1. Turn ignition switch OFF.
2. Disconnect main power window and door lock/unlock switch and front power window motor LH.
3. Check continuity between main power window and door lock/unlock switch connector and front power window motor LH connector.

Connector	Terminal	Connector	Terminal	Continuity
A		B		
Main power window and door lock/unlock switch: D7	8	Front power window motor LH: D9	2	Yes
	11		3	Yes

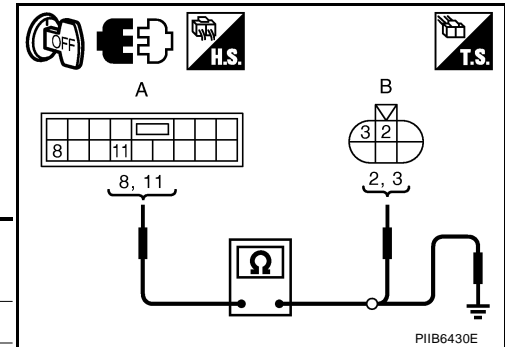

4. Check continuity between main power window and door lock/unlock switch connector and ground.

Connector	Terminal	Ground	Continuity
A			
Main power window and door lock/unlock switch: D7	8		No
	11		No

OK or NG

OK >> Replace front power window motor LH. Refer to [GW-43, "FRONT DOOR GLASS AND REGULATOR"](#).

NG >> Repair or replace harness.



# POWER WINDOW SYSTEM

## Front Power Window RH Circuit Check (Power Window and Door Lock/Unlock Switch RH Operation)

EIS0099F

### 1. CHECK POWER SUPPLY CIRCUIT

1. Turn ignition switch ON.
2. Check voltage between power window and door lock/unlock switch RH connector D105 terminal 8 and ground.

**8 - Ground : Battery voltage**

OK or NG

- OK >> Replace power window and door lock/unlock switch RH. Refer to [EI-27, "FRONT DOOR"](#).
- NG >> Repair or replace harness.

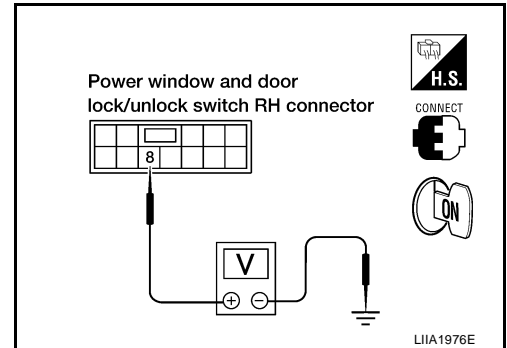

## Front Power Window Motor RH Circuit Check

EIS009EE

### 1. CHECK POWER WINDOW AND DOOR LOCK/UNLOCK SWITCH RH OUTPUT SIGNAL

1. Turn ignition switch OFF.
2. Disconnect front power window motor RH.
3. Turn ignition switch ON.
4. Check voltage between front power window motor RH connector and ground.

Connector	Terminals		Condition	Voltage (V) (Approx.)
	(+)	(-)		
Front power window motor RH: D104	1	Ground	UP	0
			DOWN	Battery voltage
	2		UP	Battery voltage
			DOWN	0

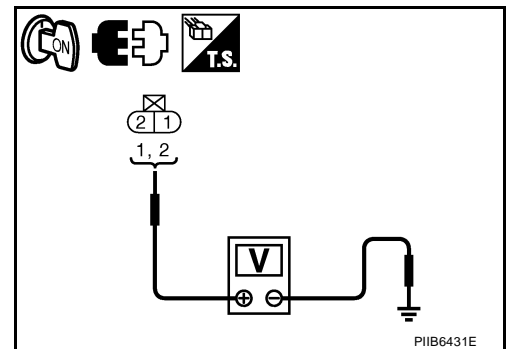

OK or NG

- OK >> Replace front power window motor RH. Refer to [GW-43, "FRONT DOOR GLASS AND REGULATOR"](#).
- NG >> GO TO 2.

### 2. CHECK FRONT POWER WINDOW MOTOR RH CIRCUIT

1. Turn ignition switch OFF.
2. Disconnect power window and door lock/unlock switch RH.
3. Check continuity between rear power window switch RH connector D105 (A) terminals 6, 7 and rear power window motor RH connector D104 (B) terminals 1, 2.

**6 - 1 : Continuity should exist.**

**7 - 2 : Continuity should exist.**

4. Check continuity between power window and door lock/unlock switch RH connector D105 (A) terminals 6, 7 and ground.

**6 - Ground : Continuity should not exist.**

**7 - Ground : Continuity should not exist.**

OK or NG

- OK >> GO TO 3.
- NG >> Repair or replace harness.

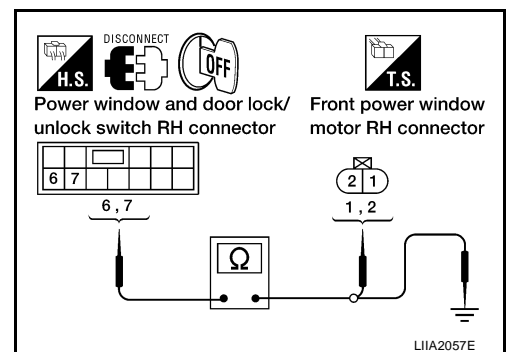

# POWER WINDOW SYSTEM

## 3. CHECK POWER WINDOW AND DOOR LOCK/UNLOCK SWITCH RH

1. Disconnect power window and door lock/unlock switch RH.
2. Check continuity between power window and door lock/unlock switch RH terminals.

	Terminals		Condition	Continuity
	Power window and door lock/unlock switch RH	6	11	DOWN
Other than above				Yes
7		12	UP	No
			Other than above	Yes

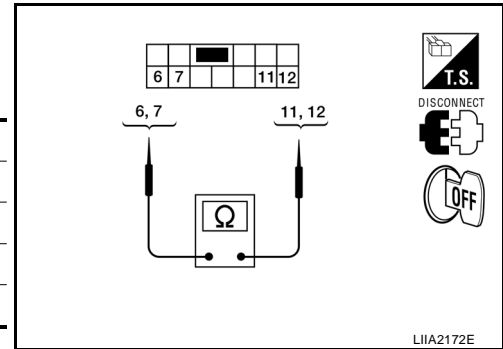

OK or NG

OK >> GO TO 4.

NG >> Replace power window and door lock/unlock switch RH. Refer to [EI-27, "FRONT DOOR"](#).

## 4. CHECK POWER WINDOW AND DOOR LOCK/UNLOCK SWITCH RH CIRCUIT

1. Disconnect main power window and door lock/unlock switch.
2. Check continuity between power window main switch connector and power window and door lock/unlock switch RH connector.

Connector	Terminal	Connector	Terminal	Continuity
A		B		
Main power window and door lock/unlock switch: D7	12	Power window and door lock/unlock switch RH: D105	11	Yes
	16		12	

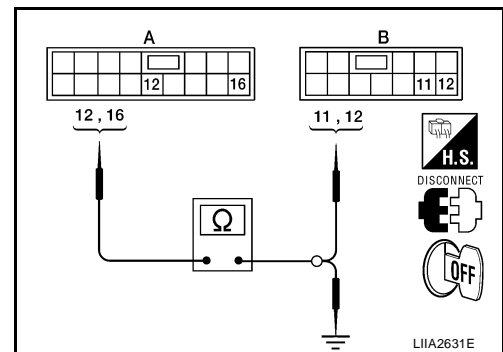

3. Check continuity power window main switch connector and ground.

Connector	Terminal	Ground	Continuity
A			
Main power window and door lock/unlock switch: D7	12	Ground	No
	16		

OK or NG

OK >> Replace main power window and door lock/unlock switch. Refer to [EI-27, "FRONT DOOR"](#).

NG >> Repair or replace harness.

## Encoder Circuit Check

EIS009CJ

### 1. CHECK FRONT POWER WINDOW MOTOR LH POWER SUPPLY

1. Turn ignition switch OFF.
2. Disconnect front power window motor LH.
3. Turn ignition switch ON.
4. Check voltage between front power window motor LH connector D9 terminal 1 and ground.

**1 - Ground : Approx. 10V**

OK or NG

OK >> GO TO 3.

NG >> GO TO 2.

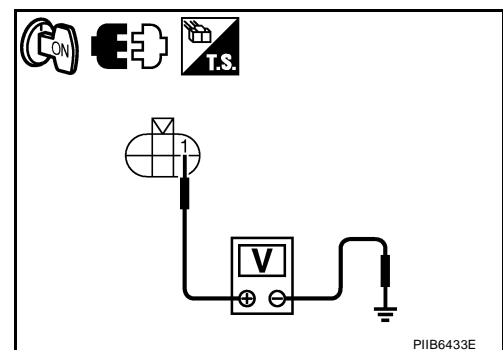

PIIB6433E

# POWER WINDOW SYSTEM

## 2. CHECK HARNESS CONTINUITY

1. Turn ignition switch OFF.
2. Disconnect main power window and door lock/unlock switch.
3. Check continuity between front power window motor LH connector and main power window and door lock/unlock switch connector.

Connector	Terminal	Connector	Terminal	Continuity
A		B		
Main power window and door lock/unlock switch: D7	15	Front power window motor LH: D9	1	Yes

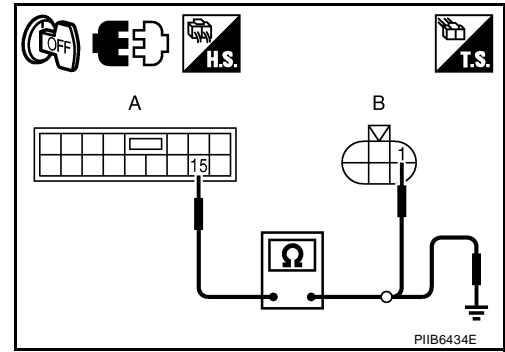

4. Check continuity between front power window motor LH connector and ground.

Connector	Terminal	Ground	Continuity
B			
Front power window motor LH: D9	15		No

OK or NG

- OK >> Replace main power window and door lock/unlock switch. Refer to [EI-27, "FRONT DOOR"](#) .  
 NG >> Repair or replace harness.

## 3. CHECK ENCODER GROUND

1. Turn ignition switch OFF.
2. Check continuity between front power window motor LH connector D9 terminal 6 and ground.

**6 - Ground : Continuity should exist.**

OK or NG

- OK >> GO TO 5.  
 NG >> GO TO 4.

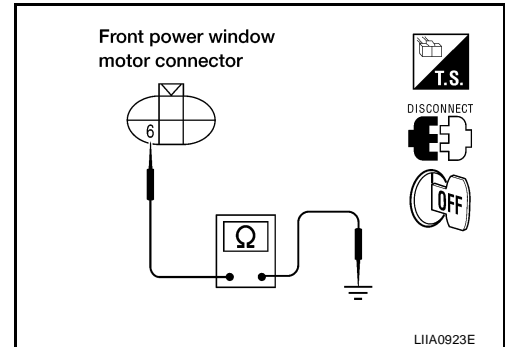

## 4. CHECK ENCODER GROUND CIRCUIT

1. Disconnect main power window and door lock/unlock switch.
2. Check continuity between front power window motor LH connector D9 terminal 6 and main power window and door lock/unlock switch connector D7 terminal 2.

**6 - 2 : Continuity should exist.**

OK or NG

- OK >> Replace main power window and door lock/unlock switch. Refer to [EI-27, "FRONT DOOR"](#) .  
 NG >> Repair or replace harness.

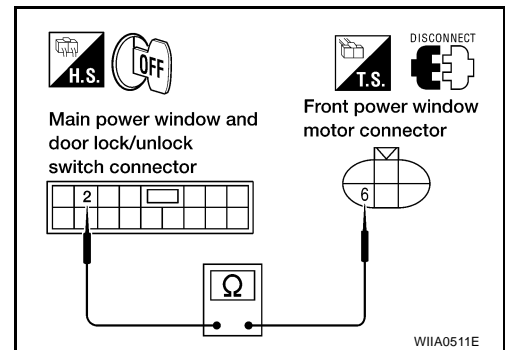

# POWER WINDOW SYSTEM

## 5. CHECK ENCODER PULSE A SIGNAL

1. Connect front power window motor LH.
2. Turn ignition switch ON.
3. Check the signal between main power window and door lock/unlock switch connector and ground with oscilloscope.

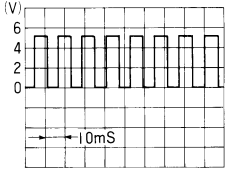
Connector	Terminals		Condition	Signal
	(+)	(-)		
D7	13	Ground	Opening	 <p>OCC3383D</p>

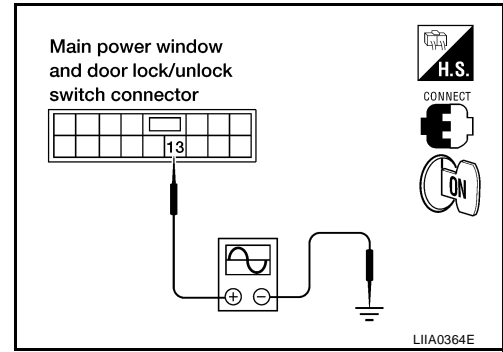

### OK or NG

- OK >> Replace main power window and door lock/unlock switch. Refer to [EI-27, "FRONT DOOR"](#) .  
 NG >> GO TO 6.

## 6. CHECK ENCODER PULSE B SIGNAL

Check the signal between main power window and door lock/unlock switch connector and ground with oscilloscope.

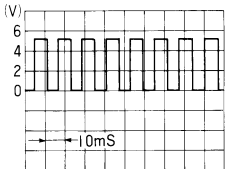
Connector	Terminals		Condition	Signal
	(+)	(-)		
D7	9	Ground	Opening	 <p>OCC3383D</p>

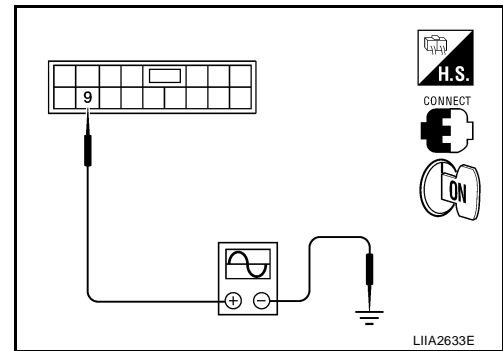

### OK or NG

- OK >> Replace main power window and door lock/unlock switch. Refer to [EI-27, "FRONT DOOR"](#) .  
 NG >> GO TO 7.

# POWER WINDOW SYSTEM

## 7. CHECK ENCODER CIRCUIT

1. Turn ignition switch OFF.
2. Disconnect front power window motor LH and main power window and door lock/unlock switch.
3. Check continuity between front power window motor LH connector and main power window and door lock/unlock switch connector.

Connector	Terminal	Connector	Terminal	Continuity
A		B		
Main power window and door lock/unlock switch: D7	9	Front power window motor LH: D9	5	Yes
	13		4	

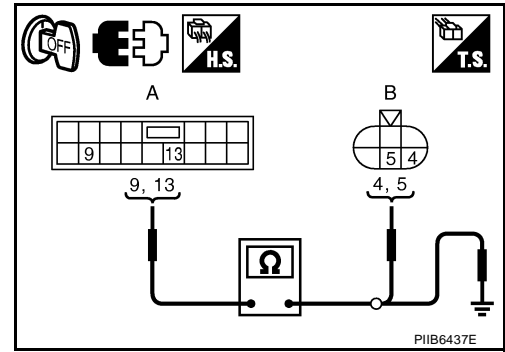

4. Check continuity between front power window motor LH connector and ground.

Connector	Terminal	Ground	Continuity
A			
Main power window and door lock/unlock switch: D7	9	Ground	No
	13		

OK or NG

- OK >> Replace front power window motor LH. Refer to [GW-43, "FRONT DOOR GLASS AND REGULATOR"](#).
- NG >> Repair or replace harness.

## Door Switch Check

### 1. CHECK FRONT DOOR SWITCH INPUT SIGNAL

**With CONSULT-II**

Check front door switches ("DOOR SW-DR" and "DOOR SW-AS") in "DATA MONITOR" mode with CONSULT-II.

Monitor item	Condition
DOOR SW-DR	OPEN: ON
	CLOSE: OFF
DOOR SW-AS	OPEN: ON
	CLOSE: OFF

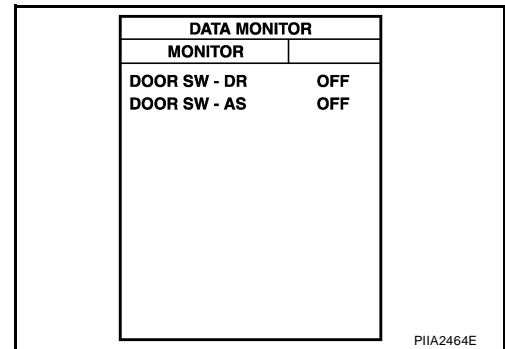

**Without CONSULT-II**

Check voltage between BCM connector and ground.

Item	Connector	Terminals		Condition	Voltage (V) (Approx.)
		(+)	(-)		
Front RH	M18	12	Ground	OPEN	0
				CLOSE	Battery voltage
Front LH	M19	47	Ground	OPEN	0
				CLOSE	Battery voltage

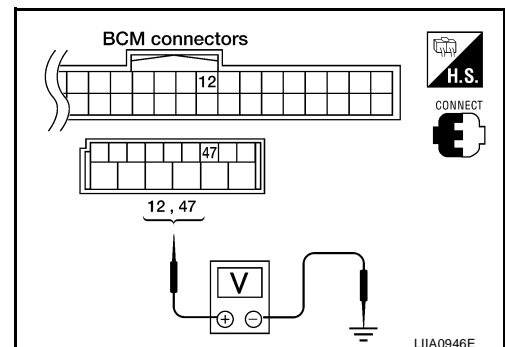

OK or NG

- OK >> Front door switch is OK.
- NG >> GO TO 2.

# POWER WINDOW SYSTEM

## 2. CHECK FRONT DOOR SWITCH CIRCUIT

1. Turn ignition switch OFF.
2. Disconnect front door switch LH or RH and BCM.
3. Check continuity between front door switch connector B8 (LH) or B108 (RH) terminal 2 and BCM connector M19 terminal 47 (LH) or connector M18 terminal 12 (RH).

**Front LH**  
**2 - 47** : Continuity should exist.

**Front RH**  
**2 - 12** : Continuity should exist.

4. Check continuity between front door switch connector B8 (LH) or B108 (RH) terminal 2 and ground.

**2 - Ground** : Continuity should not exist.

OK or NG

- OK >> GO TO 3.  
 NG >> Repair or replace harness.

## 3. CHECK DOOR SWITCH

Check continuity between each front door switch terminal 2 and body ground part of front door switch.

Terminal	Door switch	Continuity
2	Pushed	No
	Released	Yes

OK or NG

- OK >> Replace BCM. Refer to [BCS-25, "Removal and Installation of BCM"](#) .  
 NG >> Replace malfunctioning front door switch.

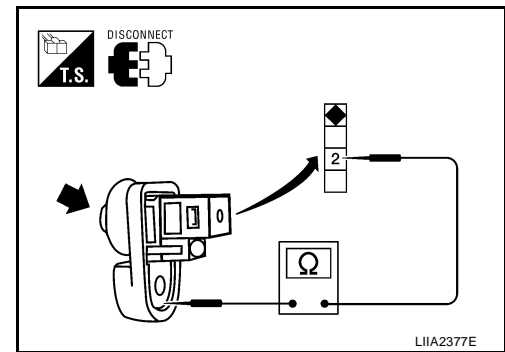
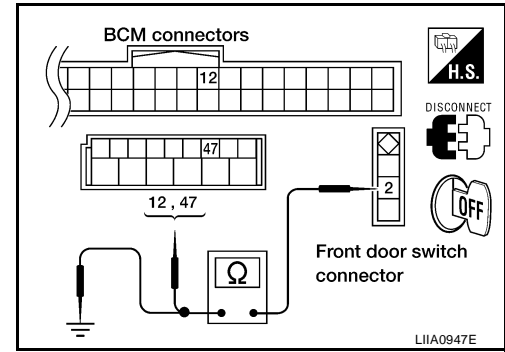

## Rear Power Window LH Circuit Check (Rear Power Window Switch LH Operation)

EIS0099K

### 1. CHECK POWER SUPPLY

1. Turn ignition switch ON.
2. Check voltage between rear power window switch LH connector D203 terminal 1 and ground.

**1 - Ground** : Battery voltage

OK or NG

- OK >> Replace rear power window switch LH. Refer to [EI-29, "REAR DOOR"](#) .  
 NG >> Repair or replace harness.

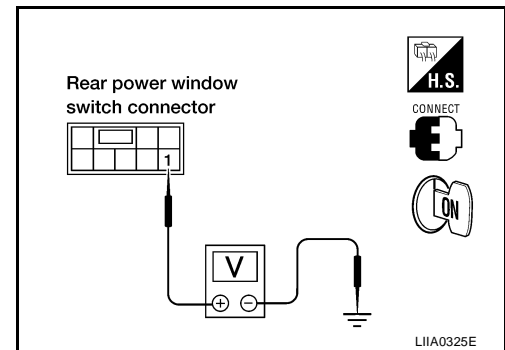

# POWER WINDOW SYSTEM

## Rear Power Window RH Circuit Check (Rear Power Window Switch RH Operation)

EIS0099M

### 1. CHECK POWER SUPPLY

- Turn ignition switch ON.
- Check voltage between rear power window switch RH connector D303 terminal 1 and ground.

**1 - Ground : Battery voltage**

OK or NG

- OK >> Replace rear power window switch RH. Refer to [EI-29, "REAR DOOR"](#).
- NG >> Repair or replace harness.

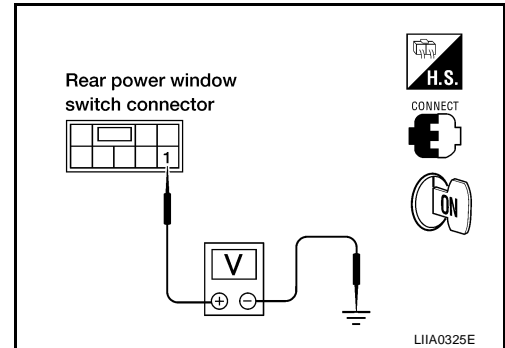

## Rear Power Window Motor LH Circuit Check

EIS0099O

### 1. CHECK REAR POWER WINDOW SWITCH LH OUTPUT SIGNAL

- Turn ignition switch OFF.
- Disconnect rear power window motor LH.
- Turn ignition switch ON.
- Check voltage between rear power window motor LH connector and ground.

Connector	Terminals		Condition	Voltage (V) (Approx.)
	(+)	(-)		
Rear power window motor LH: D204	1	Ground	UP	0
			DOWN	Battery voltage
	2		UP	Battery voltage
			DOWN	0

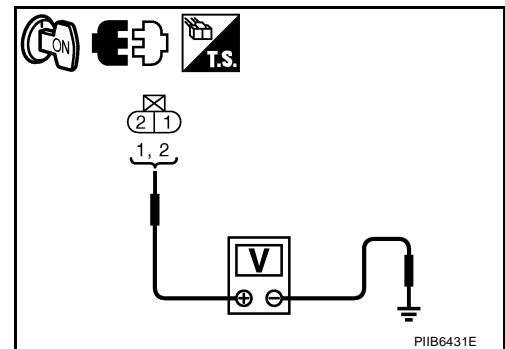

OK or NG

- OK >> Replace rear power window motor LH. Refer to [GW-47, "REAR DOOR GLASS AND REGULATOR"](#).
- NG >> GO TO 2.

### 2. CHECK REAR POWER WINDOW MOTOR LH CIRCUIT

- Turn ignition switch OFF.
- Disconnect rear power window switch LH.
- Check continuity between rear power window switch LH connector D203 (A) terminals 4, 5 and rear power window motor LH connector D204 (B) terminals 1, 2.

**4 - 1 : Continuity should exist.**

**5 - 2 : Continuity should exist.**

- Check continuity between rear power window switch LH connector D203 (A) terminals 4, 5 and ground.

**4 - Ground : Continuity should not exist.**

**5 - Ground : Continuity should not exist.**

OK or NG

- OK >> GO TO 3.
- NG >> Repair or replace harness.

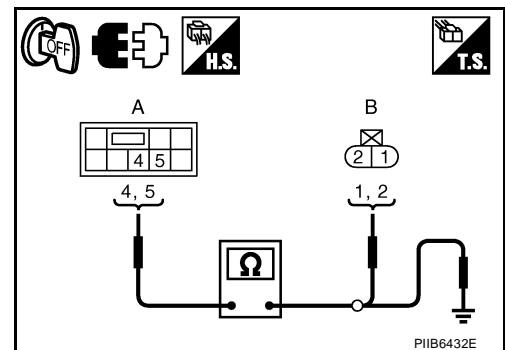

# POWER WINDOW SYSTEM

## 3. CHECK POWER WINDOW SWITCH

1. Disconnect rear power window switch LH.
2. Check continuity between rear power window switch LH terminals.

Rear power window switch LH	Terminals		Condition	Continuity
	2	5	UP	No
			Other than above	Yes
	3	4	DOWN	No
Other than above			Yes	

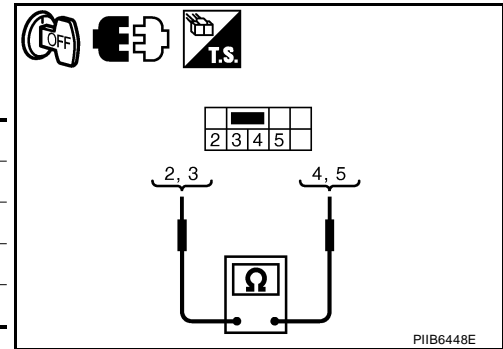

OK or NG

OK >> GO TO 4.

NG >> Replace rear power window switch LH. Refer to [EI-29, "REAR DOOR"](#).

## 4. CHECK REAR POWER WINDOW SWITCH LH CIRCUIT

1. Disconnect main power window and door lock/unlock switch.
2. Check continuity between power window main switch connector and rear power window switch LH connector.

Connector	Terminal	Connector	Terminal	Continuity
A		B		
Main power window and door lock/unlock switch: D7	1	Rear power window switch LH: D203	2	Yes
	3		3	

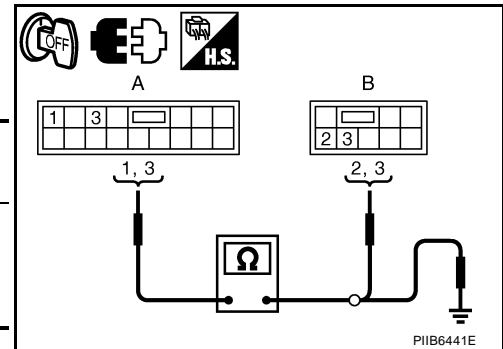

3. Check continuity power window main switch connector and ground.

Connector	Terminal	Ground	Continuity
A			
Main power window and door lock/unlock switch: D7	1	Ground	No
	3		

OK or NG

OK >> Replace main power window and door lock/unlock switch. Refer to [EI-27, "FRONT DOOR"](#).

NG >> Repair or replace harness.



# POWER WINDOW SYSTEM

EIS0099P

## Rear Power Window Motor RH Circuit Check

### 1. CHECK REAR POWER WINDOW SWITCH RH OUTPUT SIGNAL

1. Turn ignition switch OFF.
2. Disconnect rear power window motor RH.
3. Turn ignition switch ON.
4. Check voltage between rear power window motor RH connector and ground.

Connector	Terminals		Condition	Voltage (V) (Approx.)
	(+)	(-)		
Rear power window motor RH: D304	1	Ground	UP	0
			DOWN	Battery voltage
	2		UP	Battery voltage
			DOWN	0

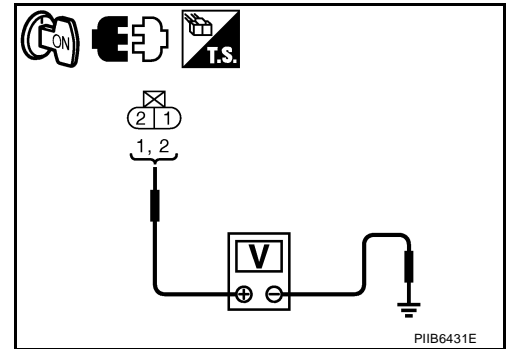

OK or NG

- OK >> Replace rear power window motor RH. Refer to [GW-47, "REAR DOOR GLASS AND REGULATOR"](#).
- NG >> GO TO 2.

### 2. CHECK REAR POWER WINDOW MOTOR RH CIRCUIT

1. Turn ignition switch OFF.
2. Disconnect rear power window switch RH.
3. Check continuity between rear power window switch RH connector D303 (A) terminals 4, 5 and rear power window motor RH connector D304 (B) terminals 1, 2.

**4 - 1 : Continuity should exist.**

**5 - 2 : Continuity should exist.**

4. Check continuity between rear power window switch RH connector D303 (A) terminals 4, 5 and ground.

**4 - Ground : Continuity should not exist.**

**5 - Ground : Continuity should not exist.**

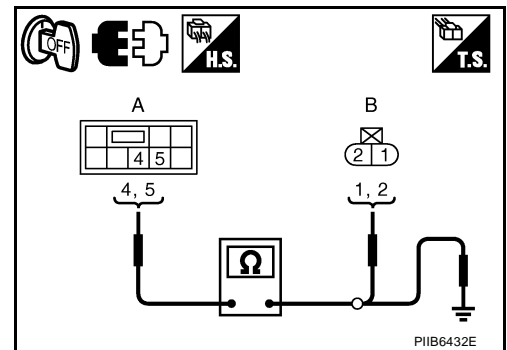

OK or NG

- OK >> GO TO 3.
- NG >> Repair or replace harness.

### 3. CHECK POWER WINDOW SWITCH

1. Disconnect rear power window switch RH.
2. Check continuity between rear power window switch RH terminals.

Rear power window switch RH	Terminals		Condition	Continuity	
	2	5			
				UP	No
				Other than above	Yes
			DOWN	No	
			Other than above	Yes	

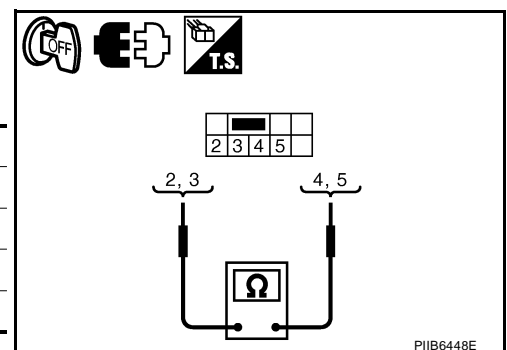

OK or NG

- OK >> GO TO 4.
- NG >> Replace rear power window switch RH. Refer to [EI-29, "REAR DOOR"](#).

# POWER WINDOW SYSTEM

## 4. CHECK REAR POWER WINDOW SWITCH RH CIRCUIT

1. Disconnect main power window and door lock/unlock switch.
2. Check continuity between power window main switch connector and rear power window switch RH connector.

Connector	Terminal	Connector	Terminal	Continuity
A		B		
Main power window and door lock/unlock switch D7	5	Rear power window switch RH D303	3	Yes
	7		2	

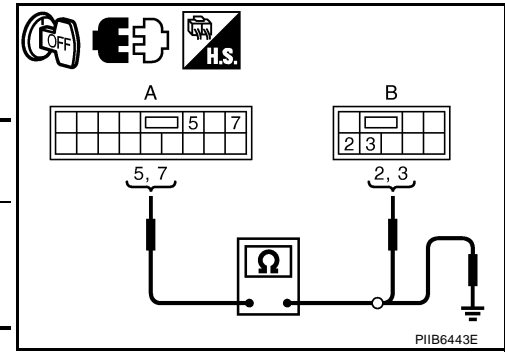

3. Check continuity power window main switch connector and ground.

Connector	Terminal		Continuity
A			
Main power window and door lock/unlock switch D7	5	Ground	No
	7		

### OK or NG

- OK >> Replace main power window and door lock/unlock switch. Refer to [EI-27, "FRONT DOOR"](#) .
- NG >> Repair or replace harness.

# FRONT DOOR GLASS AND REGULATOR

## FRONT DOOR GLASS AND REGULATOR

PF0:80300

### Removal and Installation

EIS0094Z

SEC.803

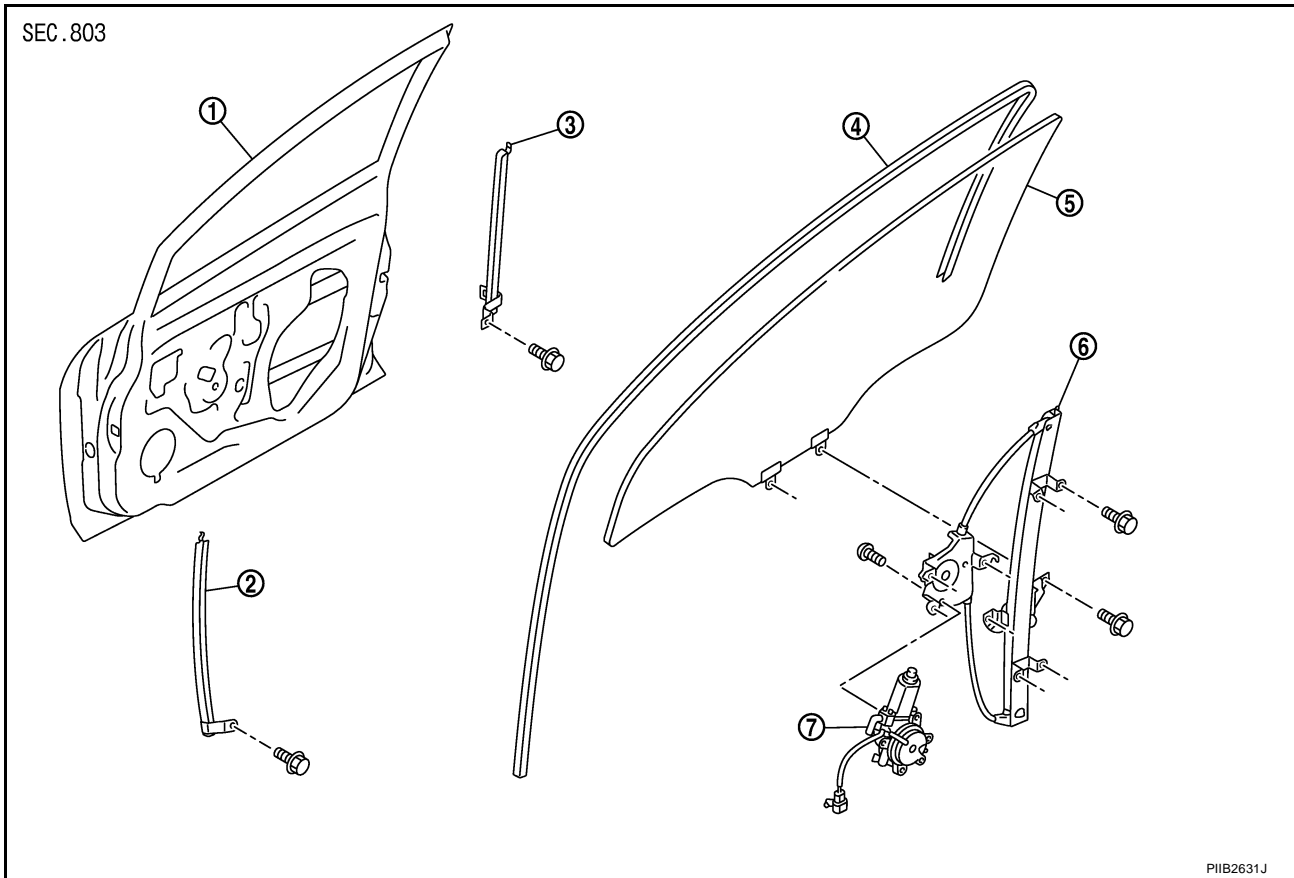

- |                                     |                       |                       |
|-------------------------------------|-----------------------|-----------------------|
| 1. Door panel                       | 2. Lower sash (front) | 3. Lower sash (rear)  |
| 4. Door glass run                   | 5. Door glass         | 6. Regulator assembly |
| 7. Power window motor (if equipped) |                       |                       |

### DOOR GLASS

#### Removal

1. Remove the front door finisher. Refer to [EI-29, "REAR DOOR"](#).
2. Disconnect the front door speaker electrical connector.
3. Position aside the sealing screen.

#### NOTE:

If sealing the screen is reused, cut the butyl-tape so that a part of butyl-tape remains on the sealing screen.

4. If equipped, reconnect the power window switch electrical connector. Operate the power window main switch to raise/lower the door window until the glass bolts can be seen.
5. Remove the door glass bolts.

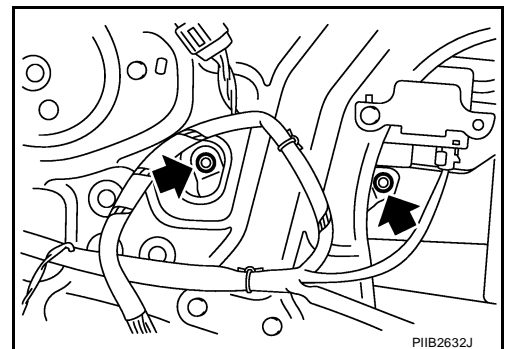

A  
B  
C  
D  
E  
F  
G  
H  
GW  
J  
K  
L  
M

## FRONT DOOR GLASS AND REGULATOR

6. While holding the door window, raise it at the rear end to pull the glass out of the sash toward the outside of the door.

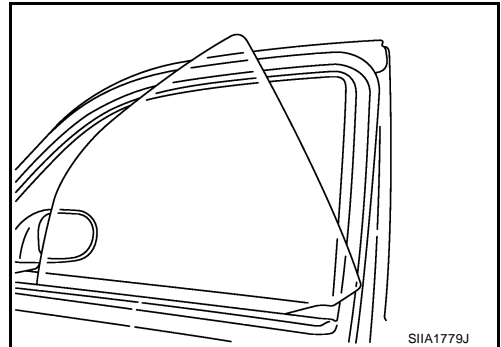

7. Remove the lower sash (rear) bolt, move the lower end portion ahead of the door panel.(3) and pull out the insertion (2) of the upper end from the door panel to remove the lower sash (rear)(1).

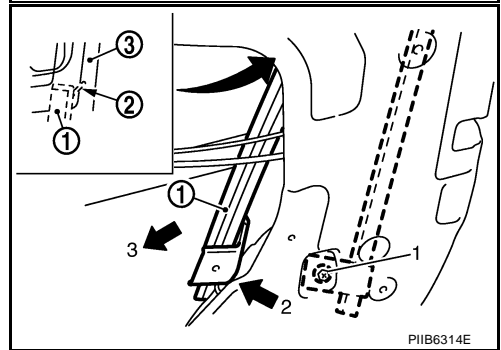

8. Remove the lower sash (front) bolt and pull out the lower sash (front) just downward to remove it.
9. Remove the door glass run from the door panel.

### Installation

Installation is in the reverse order of removal.

### REGULATOR ASSEMBLY

#### Removal

1. Remove the front door finisher. Refer to [EI-29, "REAR DOOR"](#).
2. Disconnect the harness connector of front speaker, and then remove sealing screen.

#### NOTE:

If sealing screen is reused, cut the butyl-tape so that a part of butyl-tape remains on the sealing screen.

3. If equipped, reconnect the power window switch electrical connector. Operate the power window main switch to raise/lower the door window until the door glass bolts can be seen.
4. Remove the door glass bolts.

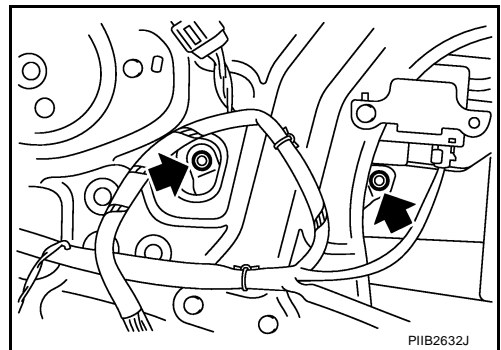

# FRONT DOOR GLASS AND REGULATOR

5. Raise the door glass and hold with a suction lifter A.

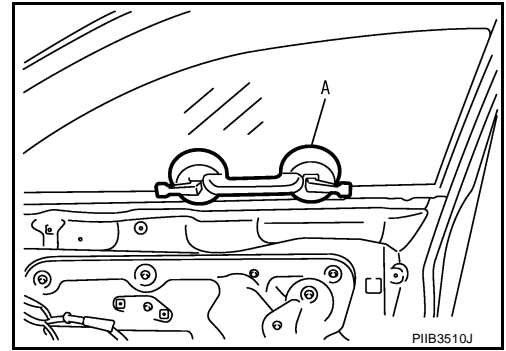

A  
B  
C  
D

6. If equipped, disconnect the harness connector from the regulator assembly.
7. Remove the door glass bolts, and then remove the regulator assembly.

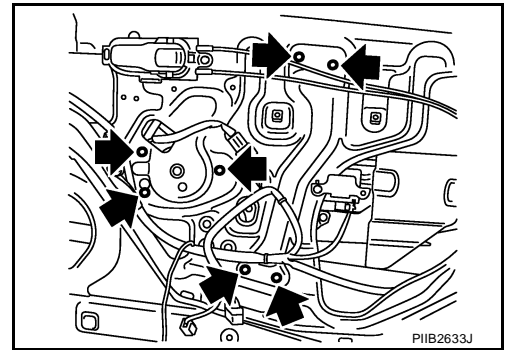

E  
F  
G  
H

## Installation

Installation is in the reverse order of removal.

## Inspection after Removal

Check the regulator assembly for the following. [If a problem is detected, grease or replace it as shown].

- Wire wear
- Regulator deformation
- Grease condition for each sliding part

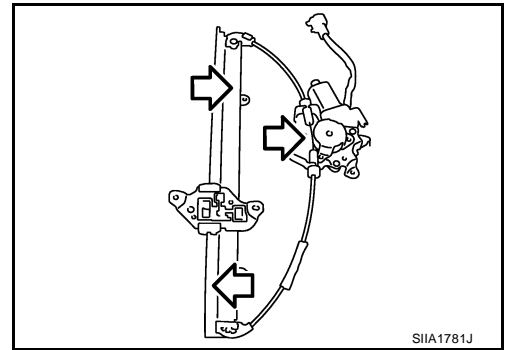

GW

J  
K  
L  
M

## Disassembly and Assembly POWER WINDOW REGULATOR ASSEMBLY

### Disassembly

Remove the power window motor from the regulator assembly.

### Assembly

Assembly is in the reverse order of disassembly.

## Inspection after Installation POWER WINDOW SYSTEM INITIALIZATION

If any of the following work has been done, initialize the system.

- Electric power supply to power window switch or motor is interrupted by blown fuse or disconnecting battery cable, etc.
- Removal and installation of the regulator assembly.
- Removal and installation of the motor from the regulator assembly.
- Removal and installation of the harness connector of the power window switch.
- Operate the regulator assembly as a unit.

EIS00950

EIS00951

# FRONT DOOR GLASS AND REGULATOR

---

- Removal and installation of the door glass.
- Removal and installation of the door glass run.

## Initialization

After installing each component to the vehicle, follow the steps below.

1. Disconnect the battery negative cable or disconnect power window switch's harness connector temporarily, then reconnect after at least 1 minute.
2. Turn ignition switch ON.
3. Open the window to its full width by operating the power window switch. (Exclude this procedure if the window is already fully opened).
4. Move the power window switch in the up direction (auto close position) and hold. Keep holding the switch even when window is completely closed, and then release after 3 seconds have passed.
5. Inspection of the anti-pinch system function.

### NOTE:

Initialization may be cancelled with continuous opening and closing operation. In this case, initialize the system.

## INSPECT THE FUNCTION OF THE ANTI-PINCH SYSTEM

1. Fully open the door glass.
  2. Place a wooden piece (wooden hammer handle, etc.) near the fully closed position.
  3. Carry out fully closing operation with auto up switch.
- Check that the glass reverses without pinching the wooden piece, is lowered approx.150 mm (5.91 in) or for 2 seconds and then stops.
  - The glass should not be raised with power window main switch while it is reversing or lowering.

### CAUTION:

- **Use care to avoid being pinched during the inspection. Do not use a hand, etc. in place of the wooden piece during the inspection.**
- **Check that auto up function is normal before inspection, following the system initialization.**

## FITTING INSPECTION

- Make sure the glass is securely fit into the glass run groove.
- Lower the glass slightly [approx. 10 to 20 mm (0.39 to 0.79 in)] and make sure the clearance to the sash is parallel. If the clearance between the glass and sash is not parallel, loosen the regulator bolts, guide rail bolts, and the glass and guide rail bolts to correct the glass position.
- Make sure the system is normal with raising and lowering the glass.

# REAR DOOR GLASS AND REGULATOR

PF0:82300

## REAR DOOR GLASS AND REGULATOR

### Removal and Installation

E/S00952

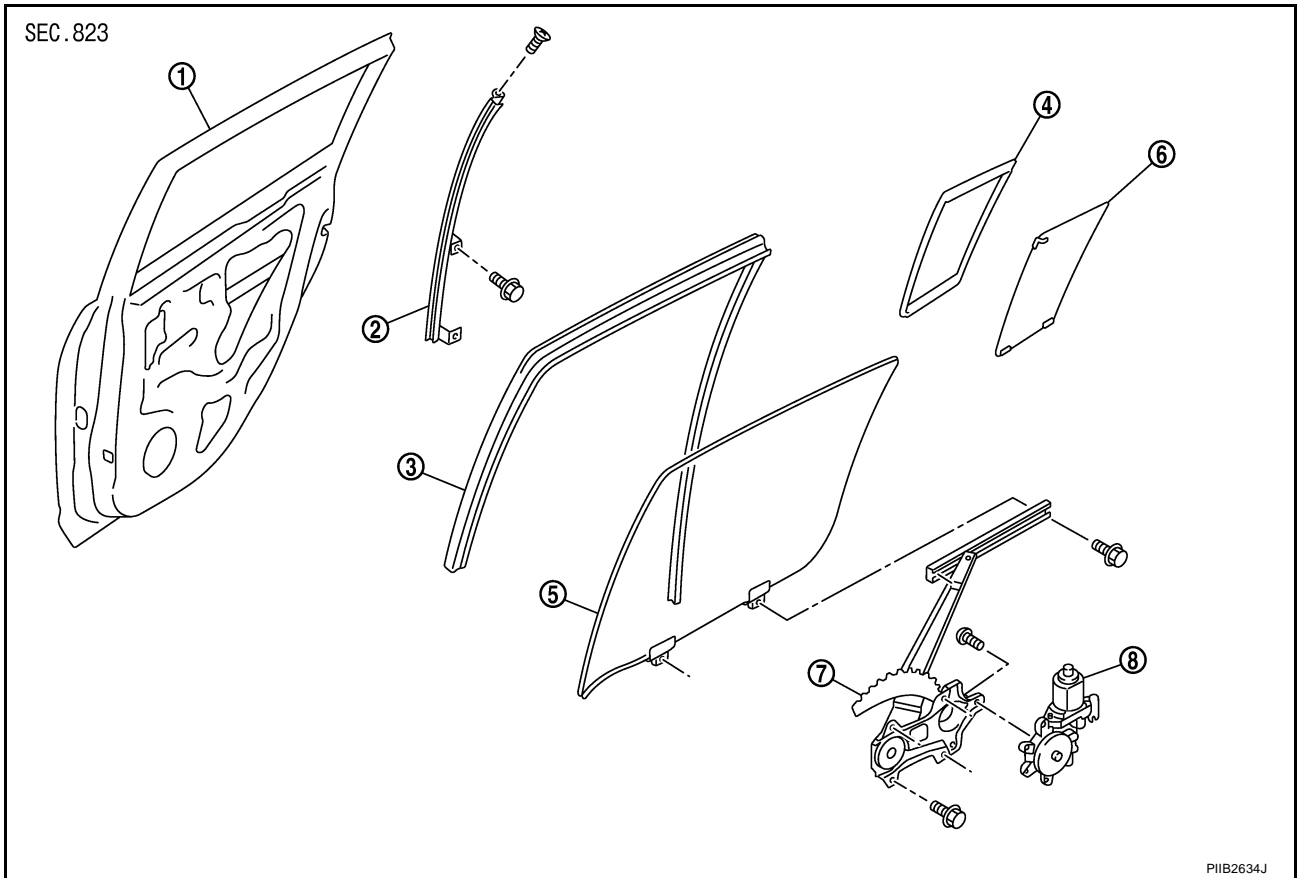

- |                                 |                                     |                    |
|---------------------------------|-------------------------------------|--------------------|
| 1. Door panel                   | 2. Partition sash                   | 3. Door glass run  |
| 4. Partition glass weatherstrip | 5. Door glass                       | 6. Partition glass |
| 7. Regulator assembly           | 8. Power window motor (if equipped) |                    |

### DOOR GLASS

#### Removal

1. Remove position aside the rear door finisher. Refer to [EI-29, "REAR DOOR"](#).
2. Disconnect the harness connector of rear door speaker.
3. Position aside the sealing screen.

#### NOTE:

If the sealing screen is reused, cut the butyl-tape so that a part of the butyl-tape remains on the sealing screen.

4. Remove partition sash bolt and screw, pull the partition sash downward and tilt the upper end of the sash forward to pull out the sash upward.

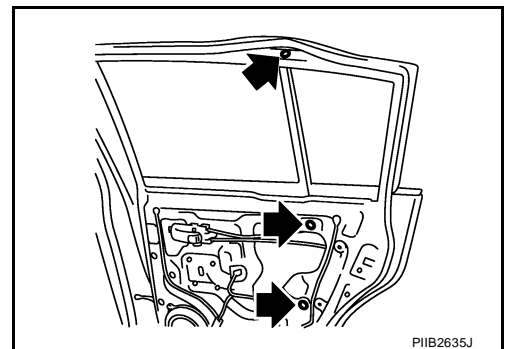

A  
B  
C  
D  
E  
F  
G  
H  
GW  
J  
K  
L  
M

## REAR DOOR GLASS AND REGULATOR

5. Pull out the partition glass in the direction as shown.

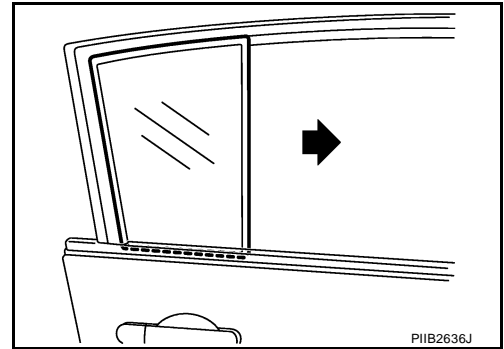

6. If equipped, operate the power window switch to raise/lower the door window until the glass bolts can be seen.

**NOTE:**

Connect the harness connector to the power window switch.

7. Remove the rear door glass bolts.
8. Pull out the rear door glass toward the outside of the door to remove.

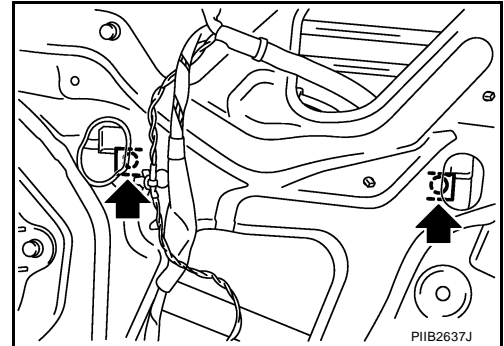

9. Remove the door glass run from the door panel.

### Installation

Installation is in the reverse order of removal.

### REGULATOR ASSEMBLY

#### Removal

1. Remove and position aside the rear door finisher. Refer to [EI-29, "REAR DOOR"](#).
2. Disconnect the harness connector of rear speaker.
3. Position aside the sealing screen.

**NOTE:**

If the sealing screen is reused, cut the butyl-tape so that a part of butyl-tape remains on the sealing screen.

4. If equipped, operate the power window switch to raise/lower the door window until the glass bolts can be seen.

**NOTE:**

Connect the harness connector to the power window switch.

5. Remove the rear door glass bolts.

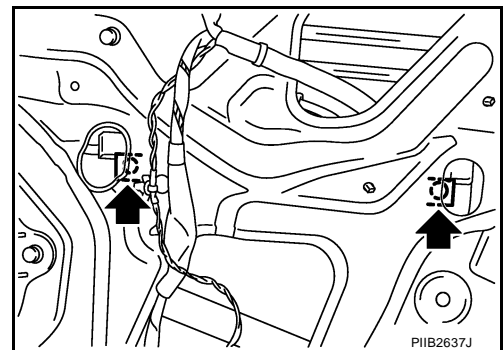

6. Raise up the door glass and hold with a suction lifter A.

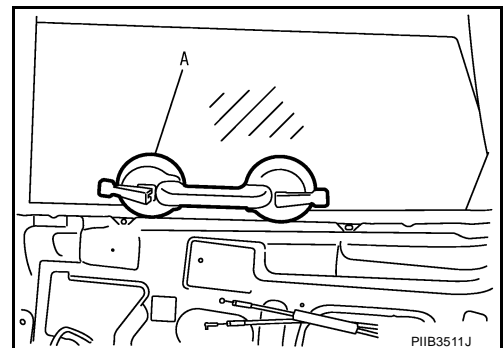



# REAR DOOR GLASS AND REGULATOR

7. Remove the regulator bolts, and then remove the regulator assembly from the door panel.

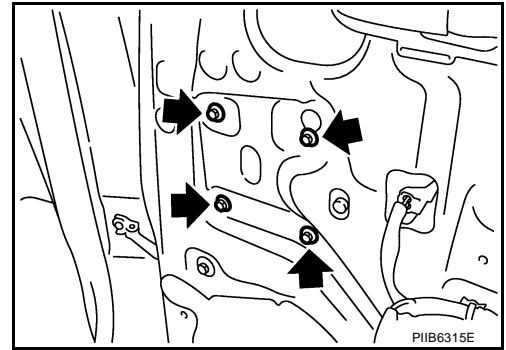

## Installation

Installation is in the reverse order of removal.

## Inspection after Removal

Check the regulator assembly for the following. [If a problem is detected, grease or replace it as shown].

- Gear wear
- Regulator deformation
- Grease condition for each sliding part

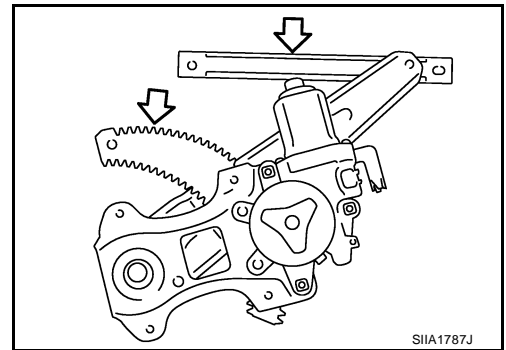

## Disassembly and Assembly POWER WINDOW REGULATOR ASSEMBLY

### Disassembly

Remove the power window motor from the regulator assembly.

### Assembly

Assembly is in the reverse order of disassembly.

## Inspection after Installation FITTING INSPECTION

- Make sure the glass is securely fit into the glass run groove.
- Lower the glass slightly [approx. 10 to 20 mm (0.39 to 0.79 in)], and make sure the clearance to the sash is parallel. If the clearance between the glass and sash is not parallel, loosen the regulator bolts, guide rail bolts, and glass and carrier plate bolts to correct the glass position.

A  
B  
C  
D  
E  
F  
G  
H  
J  
K  
L  
M

GW

# REAR WINDOW DEFOGGER

## REAR WINDOW DEFOGGER

PFP:25350

### Component Parts and Harness Connector Location

EIS009CK

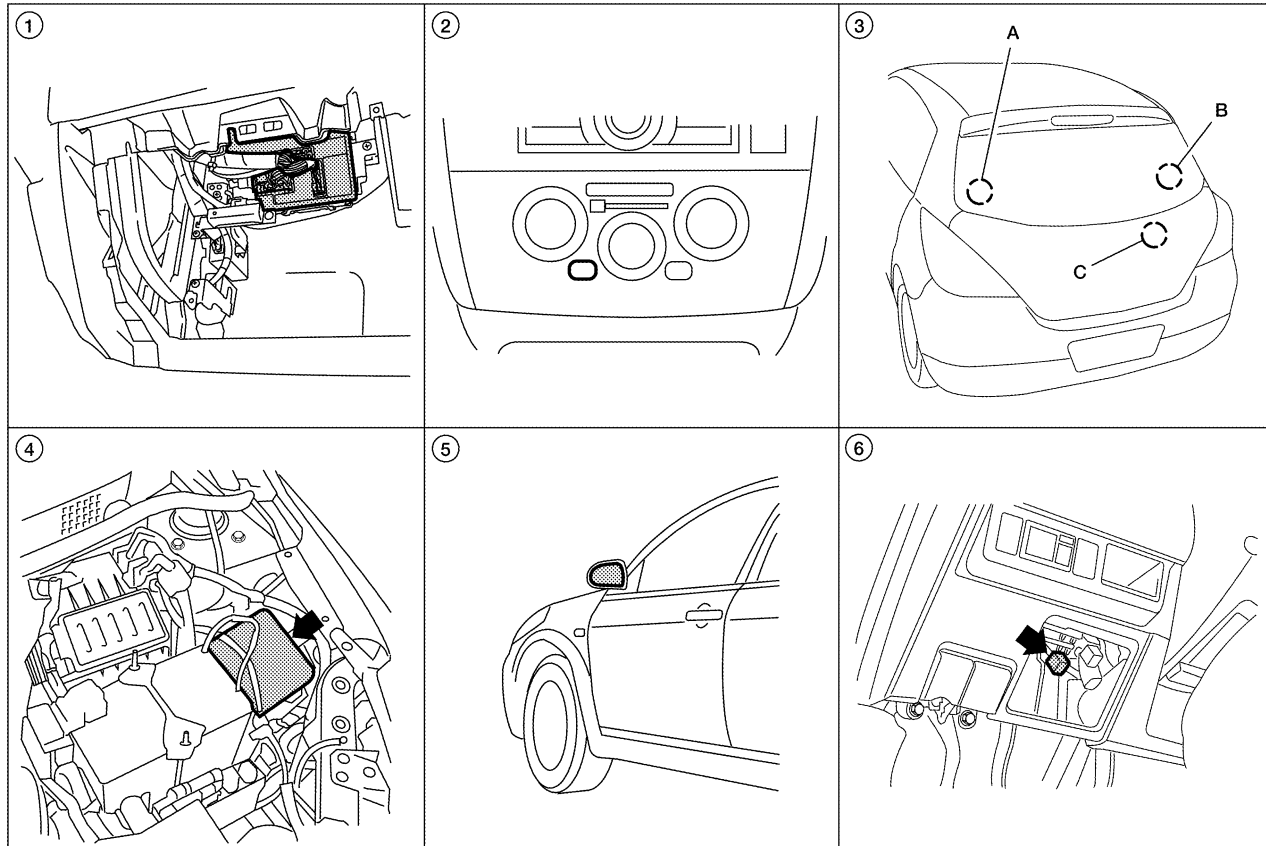

L11A2642E

1. BCM M18, M20 (view with glove box removed)
2. Front air control M33
3. A. Rear window defogger ground connector D413  
B. Rear window defogger connector D412  
C. Condenser D409, D411
4. IPDM E/R E46, E48
5. Door mirror LH D4, RH D107 (with heated mirrors)
6. Heated mirror relay M48 (with heated mirrors)

## System Description

EIS009CL

The rear window defogger system is controlled by BCM (body control module) and IPDM E/R (intelligent power distribution module engine room).

The rear window defogger only operates for approximately 15 minutes.

Power is supplied at all times

- through 15A fuses (No. 46 and 47, located in the IPDM E/R)
- to rear window defogger relay
- through 10A fuse [No. 5 (with heated mirrors), located in the fuse block (J/B)]
- to heated mirror relay terminal 3
- through 40A fusible link (letter **g**, located in the fuse and fusible link box)
- to BCM terminal 70.

With the ignition switch turned to ON or START position, power is supplied

- through ignition relay
- to rear window defogger relay (located in the IPDM E/R)
- through 10A fuse [No. 6, located in the fuse block (J/B)]
- to BCM terminal 38.

Ground is supplied

- to BCM terminal 67 and

# REAR WINDOW DEFOGGER

- to front air control terminal 8
- through body grounds M57 and M61
- to IPDM E/R terminals 39 and 59
- through body grounds E15 and E24.

When front air control (rear window defogger switch) is turned to ON, ground is supplied

- to BCM terminal 9
- through front air control terminal 3
- through front air control terminal 8
- through body grounds M57 and M61.

Then rear window defogger switch is illuminated.

Then BCM recognizes that rear window defogger switch is turned to ON.

Then it sends rear window defogger switch signals to IPDM E/R via CAN communication (CAN-H, CAN-L).

When IPDM E/R receives rear window defogger switch signals, ground is supplied

- to rear window defogger relay (located in the IPDM E/R)
- through IPDM E/R terminals 39 and 59
- through body grounds E15 and E24

Then rear window defogger relay is energized.

With power and ground supplied, rear window defogger filaments heat and defog the rear window.

When rear window defogger relay is turned to ON (with heated mirrors), power is supplied

- through heated mirror relay terminal 5
- to door mirror (LH and RH) terminal 1.

Door mirror (LH and RH) is grounded through body grounds M57 and M61.

With power and ground supplied, rear window defogger filaments heat and defog the rear window and door mirror filaments heat and defog the mirrors.

## CAN Communication System Description

EIS009CM

GW

Refer to [LAN-4, "SYSTEM DESCRIPTION"](#) .

A  
B  
C  
D  
E  
F  
G  
H  
J  
K  
L  
M

# REAR WINDOW DEFOGGER

## Wiring Diagram — DEF —

EIS009C0

### GW-DEF-01

— : DATA LINE

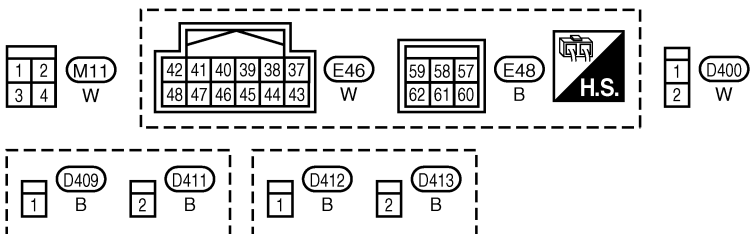
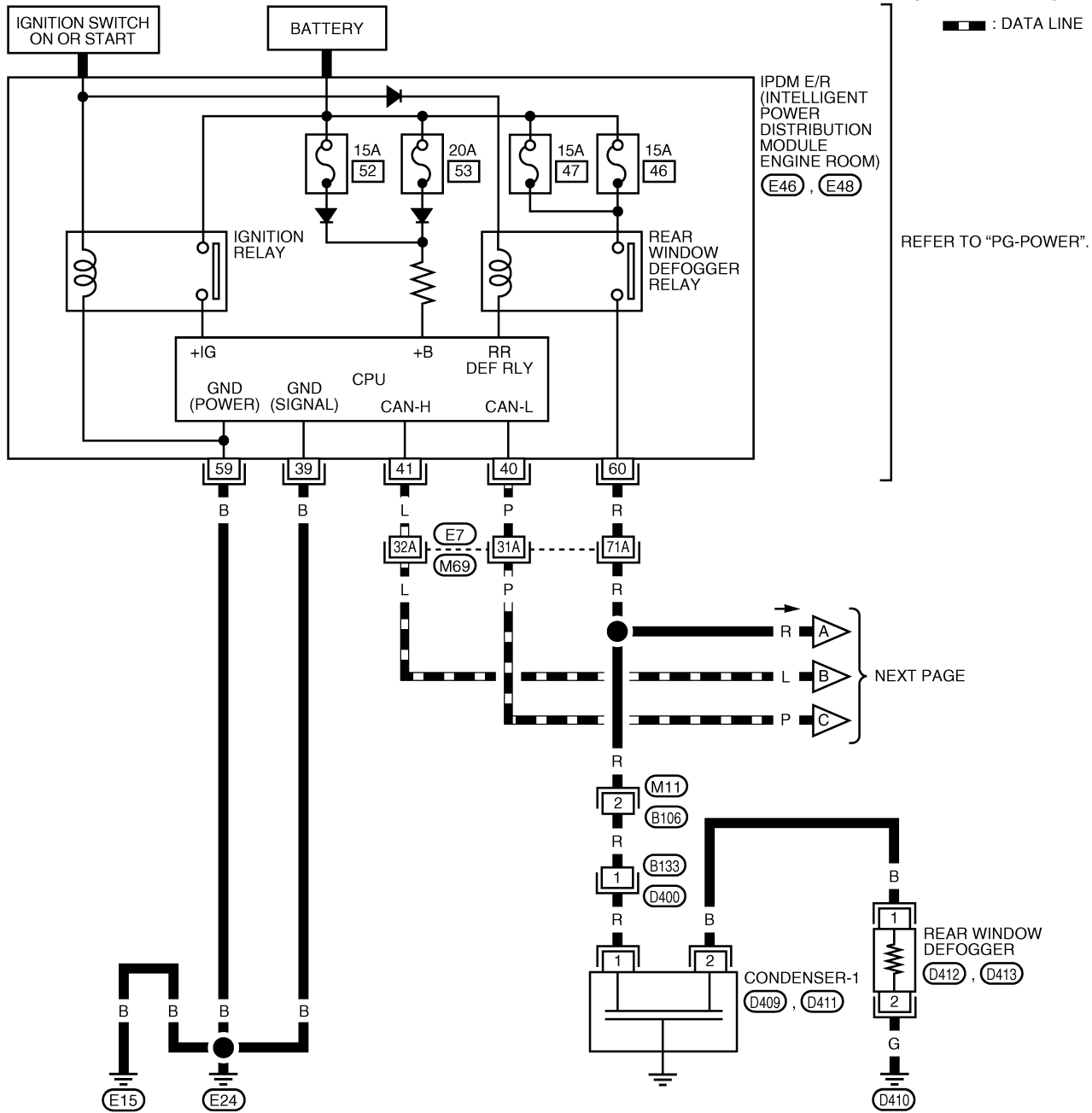

REFER TO THE FOLLOWING.  
 (M69) - SUPER MULTIPLE JUNCTION (SMJ)

LIWA0557E



# REAR WINDOW DEFOGGER

---

## Terminals and Reference Value for BCM

EIS009CP

Refer to [BCS-12, "Terminals and Reference Values for BCM"](#) .

## Terminals and Reference Value for IPDM E/R

EIS009CQ

Refer to [PG-25, "Terminals and Reference Values for IPDM E/R"](#) .

## Work Flow

EIS009CR

1. Check the symptom and customer's requests.
2. Understand the outline of system. Refer to [GW-50, "System Description"](#) .
3. According to the trouble diagnosis chart, repair or replace the cause of the malfunction. Refer to [GW-55, "Trouble Diagnoses Symptom Chart"](#) .
4. Does rear window defogger operate normally? YES: GO TO 5, NO: GO TO 3.
5. Inspection End.

# REAR WINDOW DEFOGGER

## CONSULT-II Function (BCM)

EIS009CS

CONSULT-II can display each diagnostic item using the diagnostic test modes shown following.

BCM diagnostic test item	Diagnostic mode	Content
Inspection by part	WORK SUPPORT	Supports inspections and adjustments. Commands are transmitted to the BCM for setting the status suitable for required operation, input/output signals are received from the BCM and received data is displayed.
	DATA MONITOR	Displays BCM input/output data in real time.
	ACTIVE TEST	Operation of electrical loads can be checked by sending drive signal to them.
	SELF-DIAG RESULTS	Displays BCM self-diagnosis results.
	CAN DIAG SUPPORT MNTR	The results of transmit/receive diagnosis of CAN communication can be read.
	ECU PART NUMBER	BCM part number can be read.
	CONFIGURATION	Performs BCM configuration read/write functions.

## CONSULT-II START PROCEDURE

Refer to [GI-38, "CONSULT-II Start Procedure"](#) .

## DATA MONITOR

### Display Item List

Monitor item "Operation"	Content
REAR DEF SW	"ON/OFF" Indicates (ON/OFF) condition of the rear window defogger switch.
IGN ON SW	"ON/OFF" Indicates (ON/OFF) condition of the ignition switch signal.

## ACTIVE TEST

### Display Item List

Test item	Content
REAR WINDOW DEFOGGER	Gives a drive signal to the rear window defogger to activate it.

## Trouble Diagnoses Symptom Chart

EIS009CT

Make sure other systems using the signal of the following systems operate normally.

Symptom	Diagnoses / Service procedure	Refer to page
Rear window defogger and door mirror defoggers do not operate. (With heated mirrors)	1. BCM power supply and ground circuit check	<a href="#">BCS-16</a>
	2. IPDM E/R auto active test check	<a href="#">PG-21</a>
	3. Rear window defogger switch circuit check	<a href="#">GW-56</a>
	4. Replace IPDM E/R	<a href="#">PG-29</a>
Rear window defogger does not operate. (Without heated mirrors)	1. BCM power supply and ground circuit check	<a href="#">BCS-16</a>
	2. IPDM E/R auto active test check	<a href="#">PG-21</a>
	3. Rear window defogger switch circuit check	<a href="#">GW-56</a>
	4. Rear window defogger circuit check	<a href="#">GW-57</a>
	5. Filament check	<a href="#">GW-61</a>
Rear window defogger does not operate but both door mirror defoggers operate. (With heated mirrors)	1. Rear window defogger circuit check	<a href="#">GW-57</a>
	2. Filament check	<a href="#">GW-61</a>
Door mirror defoggers do not operate but rear window defogger operates. (With heated mirrors)	1. Door mirror defogger circuit check	<a href="#">GW-60</a>
Rear window defogger switch does not light, but rear window defogger operates.	1. Replace front air control	<a href="#">MTC-61</a>

# REAR WINDOW DEFOGGER

## BCM Power Supply and Ground Circuit Check

EIS009CU

Refer to [BCS-16, "BCM Power Supply and Ground Circuit Check"](#) .

## Rear Window Defogger Switch Circuit Check

EIS009CV

### 1. CHECK REAR WINDOW DEFOGGER SWITCH OPERATION

#### With CONSULT-II

Check ("REAR DEF SW", "IGN ON SW") in DATA MONITOR mode with CONSULT-II.

**When rear window defogger switch is turned to ON**

**REAR DEF SW : ON**

**When ignition switch is turned to ON**

**IGN ON SW : ON**

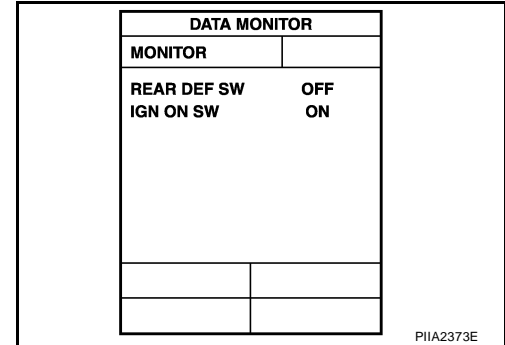

#### Without CONSULT-II

1. Turn ignition switch ON.
2. Check voltage between BCM connector and ground.

Connector	Terminals		Condition	Voltage (V) (Approx.)
	(+)	(-)		
M18	9	Ground	Rear window defogger switch is pressed	0
			Rear window defogger switch is released	5

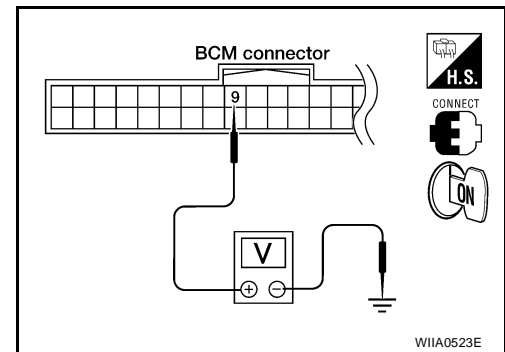

OK or NG

- OK >> Rear window defogger switch check is OK.  
 NG >> GO TO 2.

### 2. CHECK REAR WINDOW DEFOGGER SWITCH CIRCUIT HARNESS CONTINUITY

1. Turn ignition switch OFF.
2. Disconnect BCM and front air control.
3. Check continuity between BCM connector M18 (A) terminal 9 and front air control connector M33 (B) terminal 3.

**9 - 3 : Continuity should exist.**

4. Check continuity between BCM connector M18 (A) terminal 9 and ground

**9 - Ground : Continuity should not exist.**

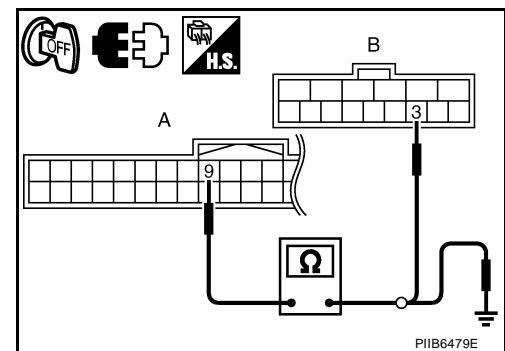

OK or NG

- OK >> GO TO 3.  
 NG >> Repair or replace harness.



# REAR WINDOW DEFOGGER

## 3. CHECK REAR WINDOW DEFOGGER SWITCH

Check continuity between front air control terminals.

Terminals	Condition	Continuity
3	Rear window defogger switch is ON (pressed)	Yes
8	Rear window defogger switch is OFF (released)	No

OK or NG

OK >> GO TO 4.

NG >> Replace front air control. Refer to [MTC-61, "Removal and Installation"](#).

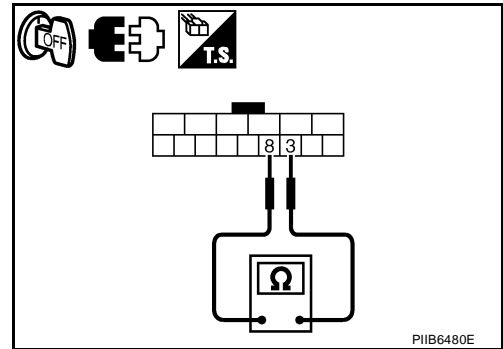

## 4. CHECK REAR WINDOW DEFOGGER SWITCH GROUND

Check continuity between front air control connector M33 terminal 8 and ground.

Connector	Terminal	Ground	Continuity
M33	8		Yes

OK or NG

OK >> GO TO 5.

NG >> Repair or replace harness.

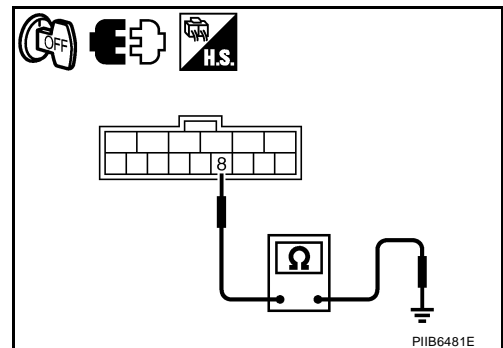

## 5. CHECK BCM OUTPUT SIGNAL

1. Connect BCM.
2. Turn ignition switch ON.
3. Check voltage between BCM connector M18 terminal 9 and ground.

**9 - Ground : Approx. 5V**

OK or NG

OK >> Replace front air control. Refer to [MTC-61, "CONTROL-LER"](#).

NG >> Replace BCM. Refer to [BCS-25, "Removal and Installation of BCM"](#).

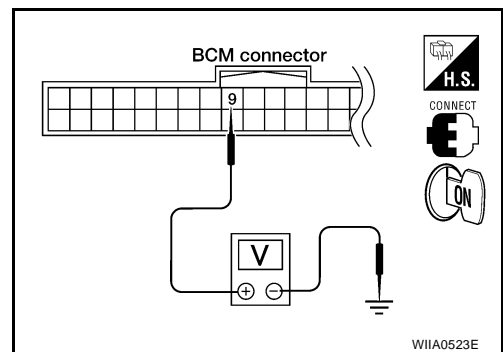

## Rear Window Defogger Circuit Check

### 1. CHECK FUSES

Check if any of the following fuses in IPDM E/R are blown.

Component Parts	Ampere	Fuse No.
IPDM E/R	15A	46
IPDM E/R	15A	47

OK or NG

OK >> GO TO 2.

NG >> If fuse is blown, be sure to eliminate cause of malfunction before installing new fuse.

# REAR WINDOW DEFOGGER

## 2. CHECK REAR WINDOW DEFOGGER POWER SUPPLY CIRCUIT

1. Turn ignition switch OFF.
2. Disconnect rear window defogger.
3. Turn ignition switch ON.
4. Check voltage between rear window defogger connector D412 terminal 1 and ground.

Connector	Terminals		Condition	Voltage (V) (Approx.)
	(+)	(-)		
D412	1	Ground	Rear window defogger switch ON	Battery voltage
			Rear window defogger switch OFF	0

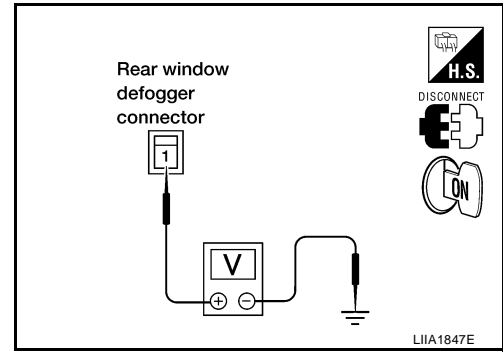

OK or NG

- OK >> GO TO 3.  
 NG >> GO TO 4.

## 3. CHECK REAR WINDOW DEFOGGER GROUND CIRCUIT

1. Turn ignition switch OFF.
2. Check continuity between rear window defogger connector D413 terminal 2 and ground.

**2 - Ground : Continuity should exist.**

OK or NG

- OK >> Check filament. Refer to [GW-61, "Filament Check"](#).
- If filament is OK.  
Check the condition of the harness and the connector.
  - If filament is NG.  
Repair filament. Refer to [GW-62, "Filament Repair"](#).
- NG >> Repair or replace harness.

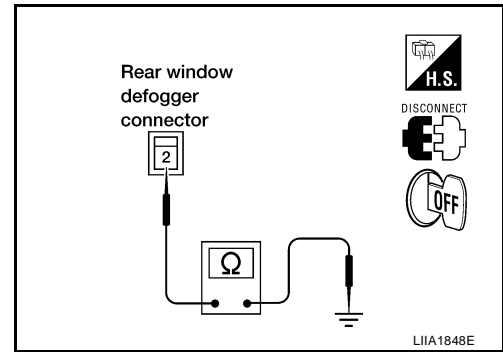

## 4. CHECK CONDENSER CIRCUIT

1. Disconnect condenser.
2. Check continuity between rear window defogger connector and condenser connector.

A		B		Continuity
Connector	Terminal	Connector	Terminal	
D412	1	D411	2	Yes

3. Check continuity between rear window defogger connector and ground.

A		Ground	Continuity
Connector	Terminal		
D412	1		No

OK or NG

- OK >> GO TO 5.  
 NG >> Repair or replace harness.

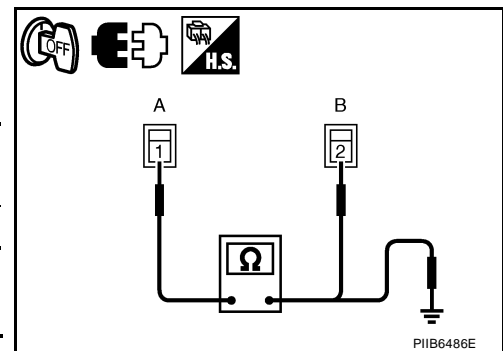

# REAR WINDOW DEFOGGER

## 5. CHECK CONDENSER

Check continuity between condenser terminals.

A		B		Continuity
Terminal		Terminal		
1		2		Yes

OK or NG

- OK >> GO TO 6.
- NG >> Replace condenser.

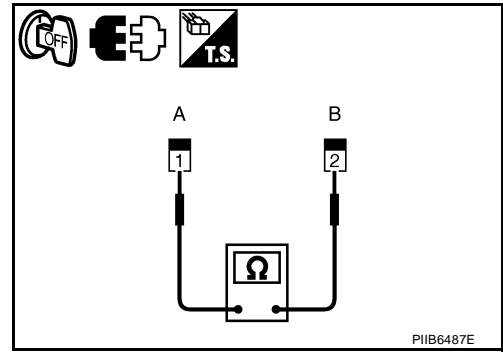

## 6. CHECK CONDENSER HARNESS CONTINUITY

1. Disconnect IPDM E/R.
2. Check continuity between condenser connector and IPDM E/R connector.

A		B		Continuity
Connector	Terminal	Connector	Terminal	
D409	1	E48	60	Yes

3. Check continuity between condenser connector and ground.

A		Ground	Continuity
Condenser connector	Terminal		
D409	1		No

OK or NG

- OK >> GO TO 7.
- NG >> Repair or replace harness.

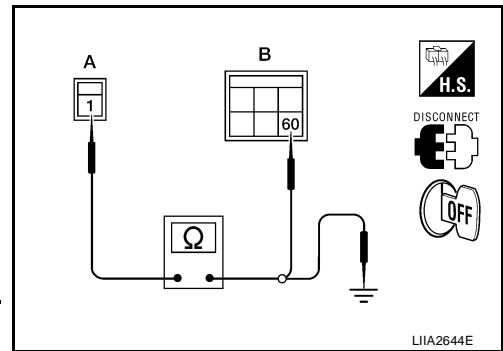

## 7. CHECK REAR WINDOW DEFOGGER RELAY OUTPUT SIGNAL

1. Connect IPDM E/R.
2. Turn ignition switch ON.
3. Check voltage between IPDM E/R connector E48 terminal 60 and ground.

Connector	Terminals		Condition	Voltage (V) (Approx.)
	(+)	(-)		
E48	60	Ground	Rear window defogger switch ON	Battery voltage
			Rear window defogger switch OFF	0

OK or NG

- OK >> Check condition of harness and connector.
- NG >> Replace IPDM E/R. Refer to [PG-29, "Removal and Installation of IPDM E/R"](#).

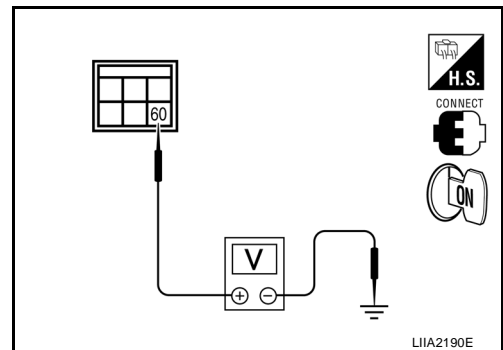

# REAR WINDOW DEFOGGER

EIS009CX

## Door Mirror Defogger Circuit Check

### 1. CHECK FUSE

Check if the following fuse in the fuse block (J/B) is blown.

Component Parts	Ampere	Fuse No.
Fuse block (J/B)	10A	5

OK or NG

OK >> GO TO 2.

NG >> If fuse is blown, be sure to eliminate cause of malfunction before installing new fuse.

### 2. CHECK HEATED MIRROR RELAY POWER SUPPLY CIRCUIT

1. Disconnect heated mirror relay.
2. Turn ignition switch ON.
3. Check voltage between heated mirror relay connector and ground.

Connector	Terminals		Voltage (V) (Approx.)
	(+)	(-)	
M48	1	Ground	Battery voltage
	3		

OK or NG

OK >> GO TO 3.

NG >> Repair or replace harness.

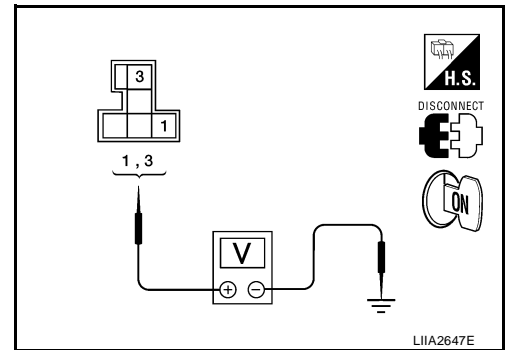

### 3. CHECK HEATED MIRROR RELAY GROUND CIRCUIT

1. Turn ignition switch OFF.
2. Check continuity between heated mirror relay connector M48 terminal 2 and ground.

**2 - Ground : Continuity should exist.**

OK or NG

OK >> GO TO 4.

NG >> Repair or replace harness.

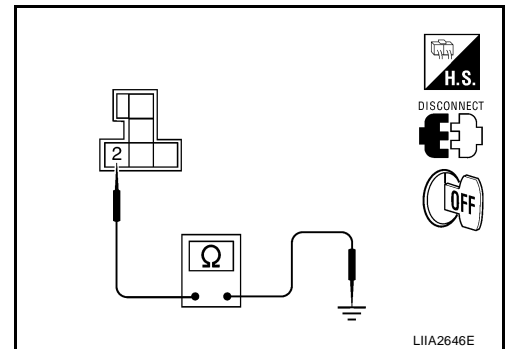

### 4. INSPECTION OF HEATED MIRROR RELAY

Check continuity between heated mirror relay terminals 3 and 5.

Condition	Continuity
12V direct current supply between terminals 1 and 2	Yes
No current supply	No

OK or NG

OK >> GO TO 5.

NG >> Replace heated mirror relay.

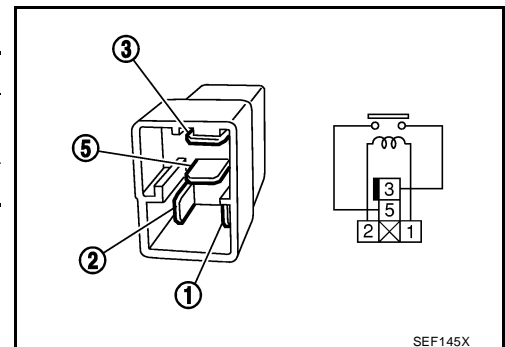

# REAR WINDOW DEFOGGER

## 5. CHECK HARNESS CONTINUITY

1. Disconnect door mirror (LH or RH).
2. Check continuity between door mirror (LH or RH) connector and heated mirror relay connector.

Connector	Terminal	Connector	Terminal	Continuity
A		B		
D4 (LH)	1	M48	5	Yes
D107 (RH)				

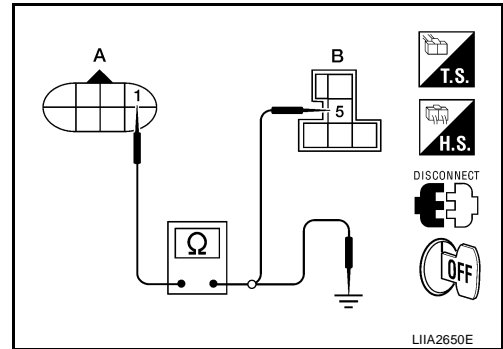

3. Check continuity between door mirror (LH or RH) connector and ground.

A		Ground	Continuity
Connector	Terminal		
D4 (LH)	1	Ground	No
D107 (RH)			

OK or NG

- OK >> Replace door mirror (LH or RH). Refer to [GW-65, "Removal and Installation"](#).
- NG >> Repair or replace harness.

## 6. CHECK GROUND CIRCUIT

Check continuity between door mirror (LH or RH) connector and ground.

Connector	Terminals		Continuity
D4 (LH)	5	Ground	Battery voltage
D107 (RH)			

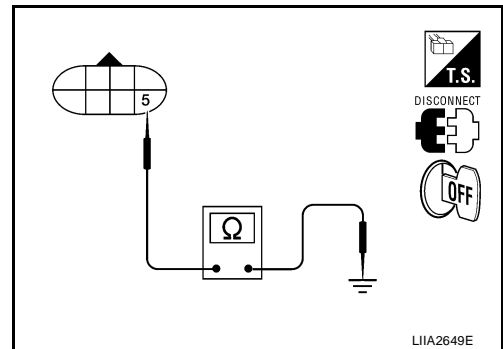

OK or NG

- OK >> GO TO 10.
- NG >> Repair or replace harness.

## Filament Check

1. When measuring voltage, wrap tin foil around the top of the negative probe. Then press the foil against the wire with your finger.

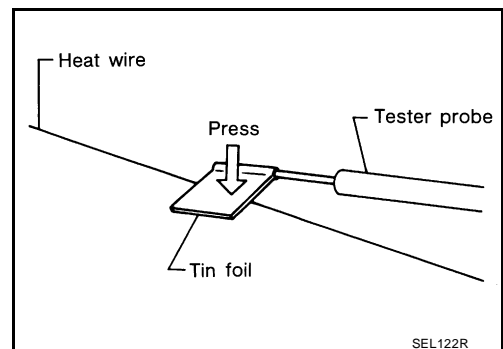

# REAR WINDOW DEFOGGER

- Attach probe circuit tester (in Volt range) to middle portion of each filament.

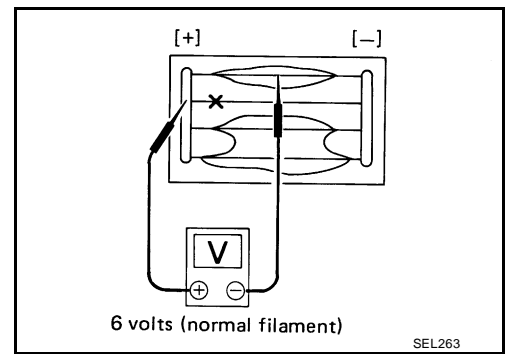

- If a filament is burned out, circuit tester registers 0 or battery voltage.
- To locate burned out point, move probe to left and right along filament. Test needle will swing abruptly when probe passes the point.

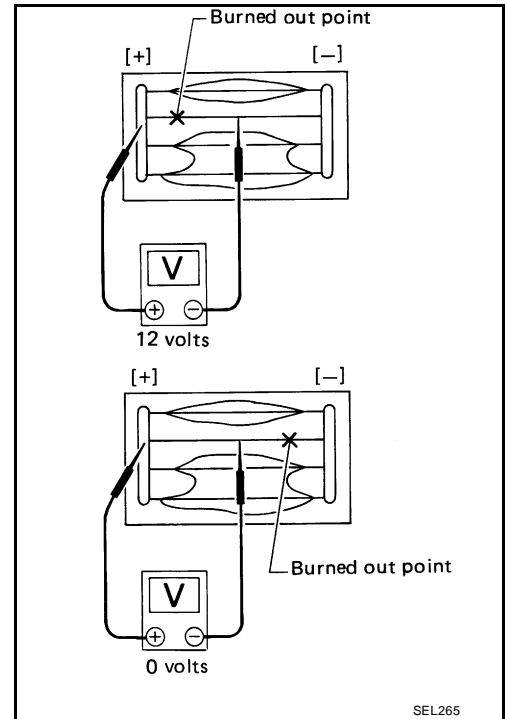

## Filament Repair REPAIR EQUIPMENT

- Conductive silver composition (DuPont No. 4817 or equivalent)
- Ruler 30 cm (11.8 in) long
- Drawing pen
- Heat gun
- Alcohol
- Cloth

## REPAIRING PROCEDURE

- Wipe broken heat wire and its surrounding area clean with a cloth dampened in alcohol.
- Apply a small amount of conductive silver composition to tip of drawing pen. Shake silver composition container before use.
- Place ruler on glass along broken line. Deposit conductive silver composition on break with drawing pen. Slightly overlap existing heat wire on both sides [preferably 5 mm (0.20 in)] of the break.

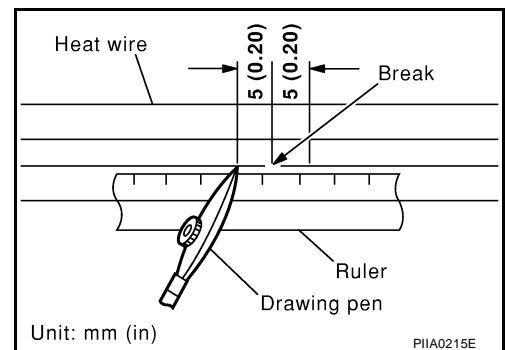

## REAR WINDOW DEFOGGER

4. After repair has been completed, check repaired wire for continuity. This check should be conducted 10 minutes after silver composition is deposited. Do not touch repaired area while test is being conducted.

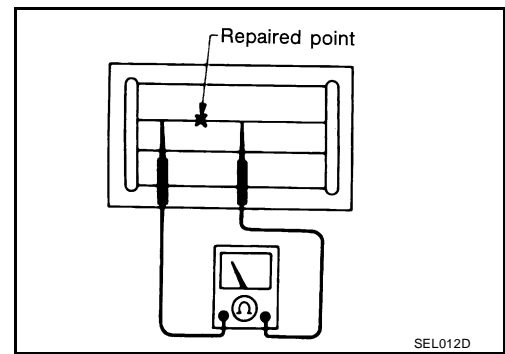

5. Apply a constant stream of hot air directly to the repaired area for approximately 20 minutes with a heat gun. A minimum distance of 3 cm (1.2 in) should be kept between repaired area and hot air outlet. If a heat gun is not available, let the repaired area dry for 24 hours.

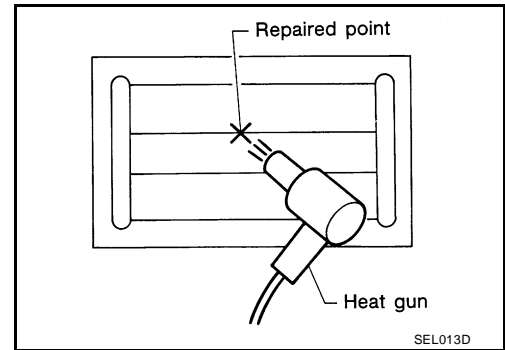

A  
B  
C  
D  
E  
F  
G  
H

GW

J  
K  
L  
M

# DOOR MIRROR

PFP:96301

## DOOR MIRROR

### Wiring Diagram — MIRROR —

EIS0095N

## GW-MIRROR-01

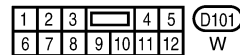
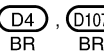
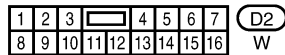
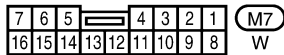
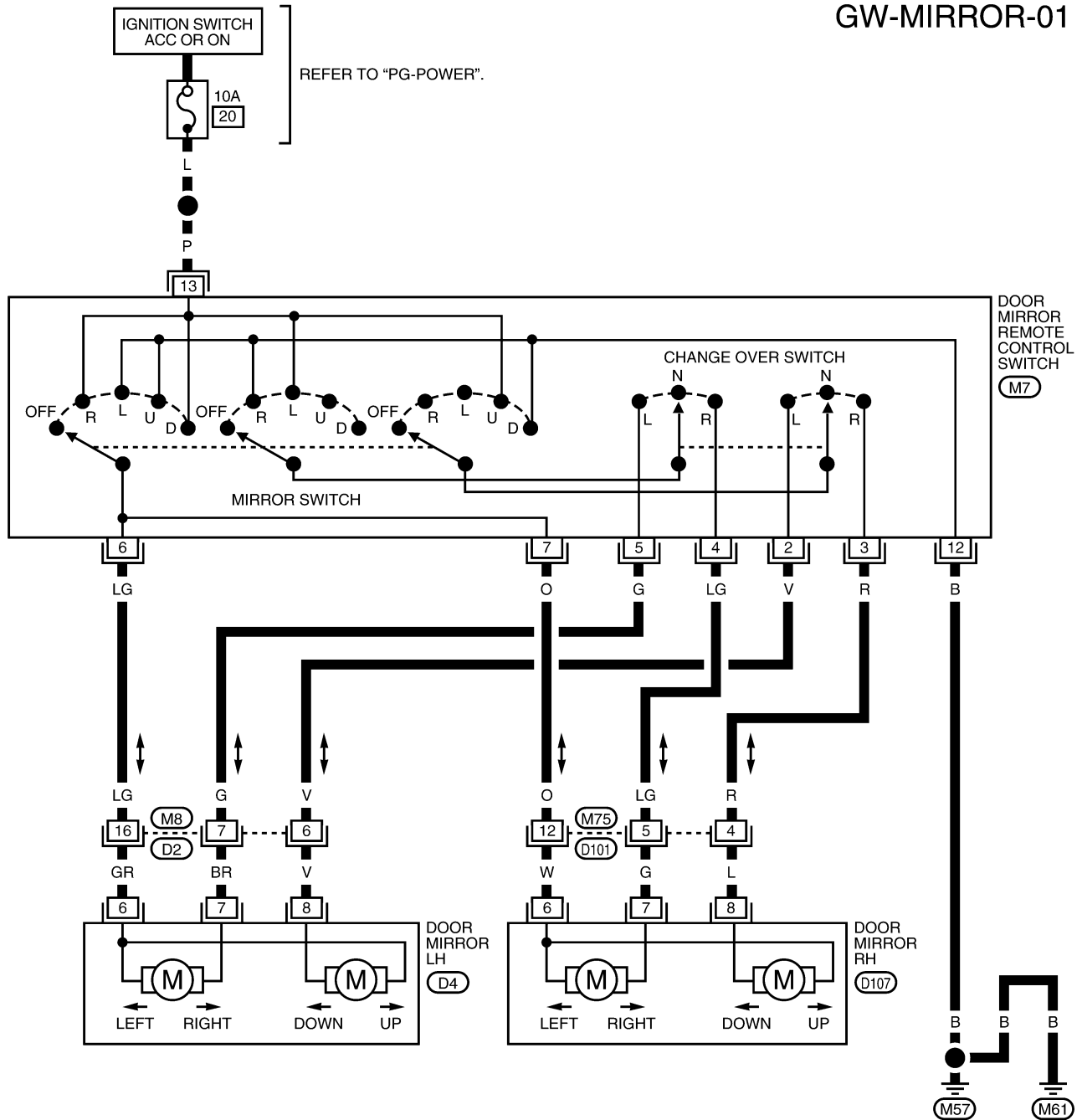

LIWA0559E



# DOOR MIRROR

## Removal and Installation

EIS00950

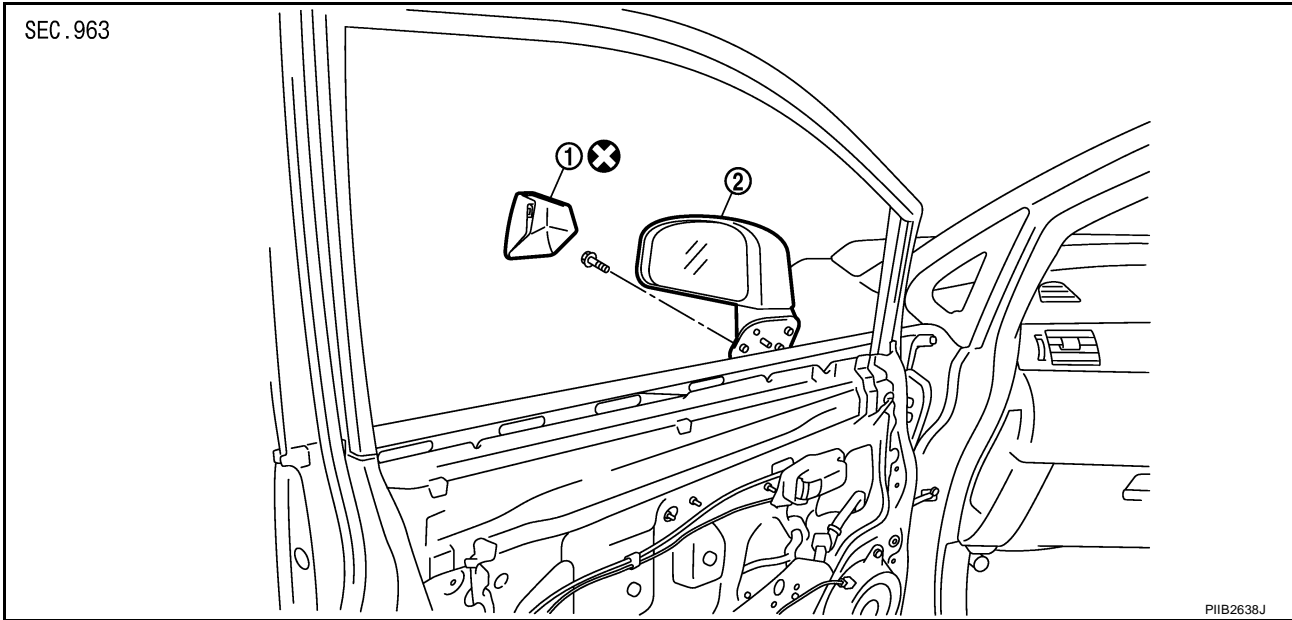

1. Door mirror base cover
2. Door mirror

**CAUTION:**  
Be careful not to damage the mirror body.

### REMOVAL

1. Remove the front door finisher. Refer to [EI-29, "REAR DOOR"](#).
2. Disconnect the harness connector of door mirror.
3. Using a suitable tool remove door mirror base cover.

**CAUTION:**

- Do not reuse the disassembled door mirror base cover.
- Be careful not to damage the door panel with a tool.

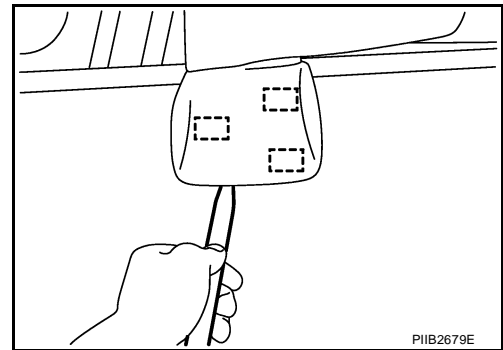

4. Remove the door mirror bolts, and remove the door mirror assembly.

**CAUTION:**

Do not use force to remove the door mirror assembly by force because it is attached by clip.

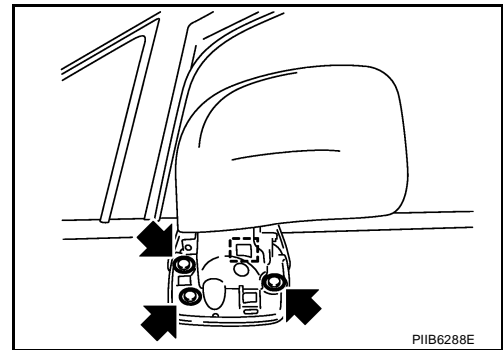

### INSTALLATION

Installation is in the reverse order of removal.

A  
B  
C  
D  
E  
F  
G  
H  
GW  
J  
K  
L  
M

# DOOR MIRROR

EIS0095P

## Disassembly and Assembly

### DISASSEMBLY

1. Pull out all the terminals from the connector.

**NOTE:**

Before pulling out the terminal, note the connector terminal arrangement.

2. Turn the mirror glass surface upward.
3. Apply a protective tape A to the housing.
4. Insert a suitable tool B into the concave gap between mirror holder (1) and power unit (2). Push up tabs (3) (2 locations) on mirror holder to disengage lower part of mirror holder, and remove mirror body assembly.

**NOTE:**

When pushing up the tabs, do not forcefully push up only 1 concave position but try to push up 2 concave positions.

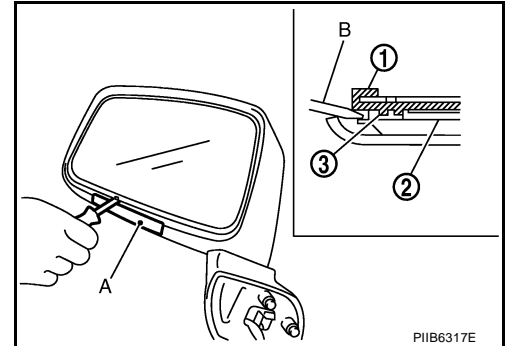

5. Remove the mirror body (1) from the mirror housing assembly (2).

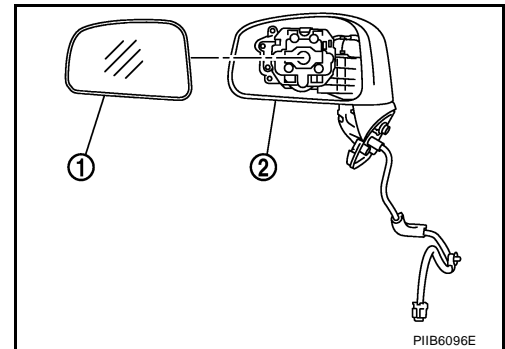

### ASSEMBLY

1. Warm the lower tabs with a dryer or equivalent.

**NOTE:**

Warm the lower tabs sufficiently before installing the mirror body. The tabs may be broken if it is cold. Be especially careful in the winter.

2. Engage upper tabs of mirror body (1) with power unit (2). Then, press lower part of mirror glass down until the lower part snaps to allow engagement of lower tabs.

**NOTE:**

After installation, visually check that the lower tabs are securely engaged when viewed from the bottom of mirror surface.

3. Insert the harness terminals into the connector.

**NOTE:**

Make sure to insert the harness terminals into the correct connector. Do not confuse the locations.

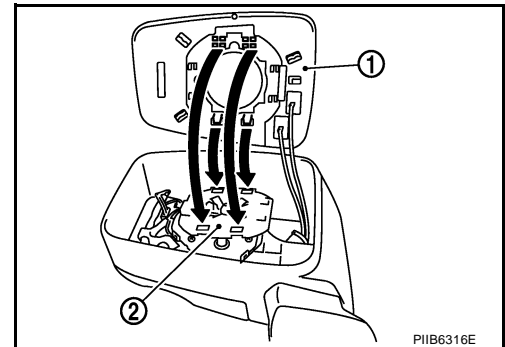

# INSIDE MIRROR

PFP:96321

## INSIDE MIRROR

EIS0095Q

### Removal and Installation

#### REMOVAL

Slide the inside mirror upward, and then remove inside mirror (1) from the mirror base (2).

#### CAUTION:

- Do not use excessive force to remove the inside mirror because it is inserted tightly into the mirror base.
- Do not reuse the inside mirror disassembled from mirror base.

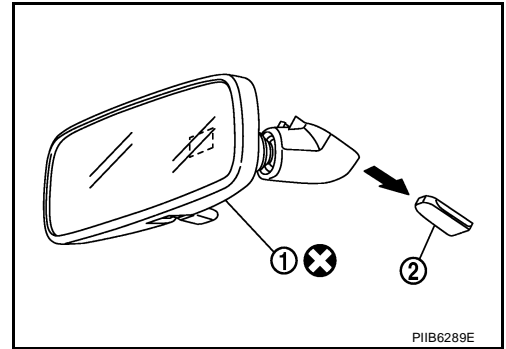

#### INSTALLATION

Installation is in the reverse order of removal.

#### CAUTION:

Be sure to insert the inside mirror to the mirror base until the pawl is engaged to the mirror base.

A  
B  
C  
D  
E  
F  
G  
H  
J  
K  
L  
M

GW

**INSIDE MIRROR**

---