

SECTION **FAX**
FRONT AXLE

A
B
C

FAX

CONTENTS

E

PRECAUTIONS	2	REMOVAL	8	F
Caution	2	INSPECTION AFTER REMOVAL	9	
PREPARATION	3	INSTALLATION	9	
Special Service Tools	3	Removal and Installation (Right Side)	10	G
Commercial Service Tools	3	COMPONENTS	10	
NOISE, VIBRATION AND HARSHNESS (NVH)		REMOVAL	10	
TROUBLESHOOTING	4	INSPECTION AFTER REMOVAL	11	H
NVH Troubleshooting Chart	4	INSTALLATION	11	
FRONT WHEEL HUB AND KNUCKLE	5	Disassembly and Assembly (Left Side)	12	
On-Vehicle Inspection and Service	5	DISASSEMBLY	12	
FRONT WHEEL BEARING INSPECTION	5	INSPECTION AFTER DISASSEMBLY	13	I
Removal and Installation	5	ASSEMBLY	14	
COMPONENT	5	Disassembly and Assembly (Right Side)	18	
REMOVAL	5	DISASSEMBLY	18	J
INSPECTION AFTER REMOVAL	7	INSPECTION AFTER DISASSEMBLY	20	
INSTALLATION	7	ASSEMBLY	20	
FRONT DRIVE SHAFT	8	SERVICE DATA AND SPECIFICATIONS (SDS)	25	K
On-Vehicle Inspection and Service	8	Drive Shaft	25	
Removal and Installation (Left Side)	8	Dynamic Damper	25	
COMPONENTS	8			L

M

PRECAUTIONS

PRECAUTIONS

PF:00001

Caution

EDS003QM

Observe the following precautions when disassembling and assembling drive shaft.

- Joint sub-assembly does not disassemble because it is non-overhaul parts.
- Perform work in a location which is as dust-free as possible.
- Before disassembling and assembling, clean the outside of parts.
- Prevention of the entry of foreign objects must be taken into account during disassembly of the service location.
- Disassembled parts must be carefully reassembled in the correct order. If work is interrupted, a clean cover must be placed over parts.
- Paper shop cloths must be used. Fabric shop cloths must not be used because of danger of lint adhering to parts.
- Disassembled parts (except for rubber parts) should be cleaned with kerosene which shall be removed by blowing with air or wiping with paper shop cloths.

PREPARATION

PREPARATION

PFP:00002

Special Service Tools

EDS003QN

The actual shapes of Kent-Moore tools may differ from those of special service tools illustrated here.

Tool number (Kent-Moore No.) Tool name	Description
KV40107300 (—) Boot Band crimping tool	Installing boot bands
KV38105500 (J-33904) Differential side oil seal protector	Installing drive shaft LH a: 40 mm (1.57 in) dia.
KV38106700 (J-34296) Differential side oil seal protector	Installing drive shaft RH a: 36 mm (1.42 in) dia.

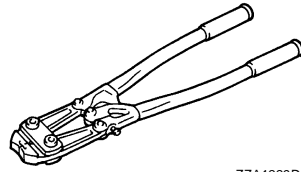

ZZA1229D

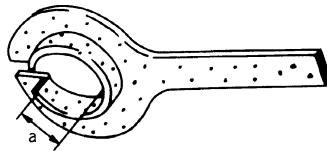

ZZA0835D

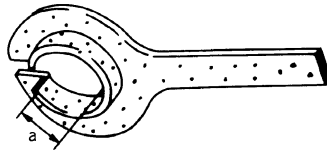

ZZA0835D

Commercial Service Tools

EDS003QO

Tool name	Description
Power tool	<ul style="list-style-type: none"> ● Removing wheel nuts ● Removing torque member bolts ● Removing hub lock nut

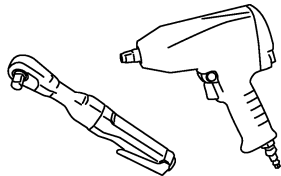

PBIC0190E

A
B
C
FAX
E
F
G
H
I
J
K
L
M

NOISE, VIBRATION AND HARSHNESS (NVH) TROUBLESHOOTING

NOISE, VIBRATION AND HARSHNESS (NVH) TROUBLESHOOTING

PF0:00003

NVH Troubleshooting Chart

EDS003QP

Use chart below to help you find the cause of the symptom. If necessary, repair or replace these parts.

Symptom		Possible cause and SUSPECTED PARTS	Reference page											
			Excessive joint angle	Joint sliding resistance	Imbalance	Improper installation, looseness	Parts interference	Wheel bearing damage	FRONT SUSPENSION	FRONT AXLE	TIRES	ROAD WHEELS	DRIVE SHAFT	BRAKES
DRIVE SHAFT	Noise		x	x					x	x	x		x	x
	Shake		x		x				x	x	x		x	x
FRONT AXLE	Noise					x	x	x	x		x	x	x	x
	Shake					x	x	x	x		x	x	x	x
	Vibration					x	x	x	x		x			x
	Shimmy					x	x		x		x		x	x
	Judder					x			x		x		x	x
	Poor quality ride or handling					x	x		x		x			

x: Applicable

FRONT WHEEL HUB AND KNUCKLE

FRONT WHEEL HUB AND KNUCKLE

PFP:40202

On-Vehicle Inspection and Service

EDS003TJ

- Check the axle and suspension parts for excessive play, wear, or damage.
- Shake each front wheel to check for excessive play as shown.

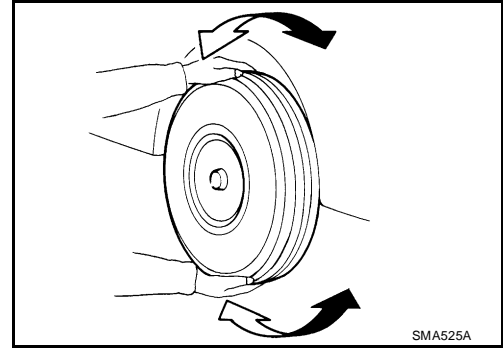

FRONT WHEEL BEARING INSPECTION

- Move wheel hub and bearing assembly in the axial direction by hand. Make sure the axial end play is within specification.

Axial end play : 0.05 mm (0.002 in) or less

- Check that the wheel hub bearing operates smoothly.
- Replace the wheel hub assembly if the axial end play exceeds specification, or if the wheel bearing does not turn smoothly. Refer to [RAX-4, "Removal and Installation"](#).

CAUTION:

The wheel hub assembly does not require maintenance. If any of the following symptoms are noted, replace the wheel hub assembly.

- Growling noise is emitted from the wheel hub bearing during operation.
- Wheel hub bearing drags or turns roughly.

Removal and Installation COMPONENT

EDS003QR

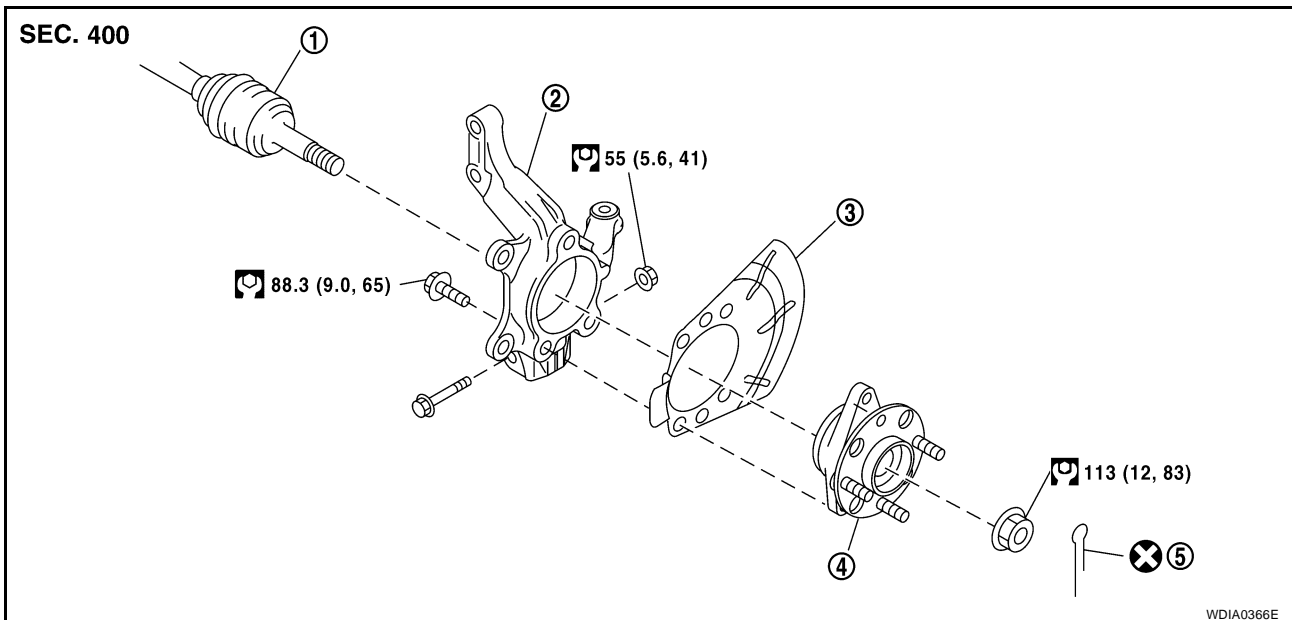

1. Drive shaft
2. Steering knuckle
3. Splash guard
4. Wheel hub and bearing assembly
5. Cotter pin

REMOVAL

1. Remove wheel and tire using power tool. Refer to [WT-6, "Rotation"](#).

FRONT WHEEL HUB AND KNUCKLE

- Without disassembling the hydraulic lines, remove the torque member bolts using power tool. Then reposition the torque member and brake caliper assembly aside with wire. Refer to [BR-24, "FRONT DISC BRAKE"](#).

CAUTION:

Do not depress brake pedal while brake caliper is removed.

- Put alignment marks on disc rotor and wheel hub and bearing assembly, then remove disc rotor.

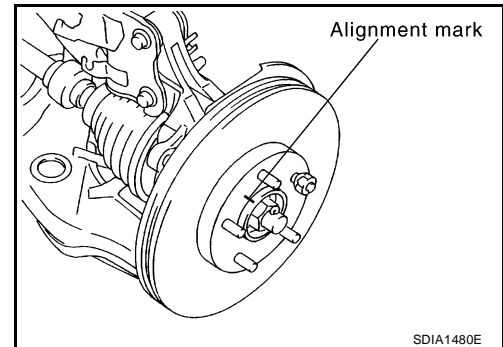

- Remove wheel sensor from steering knuckle. Refer to [BRC-33, "WHEEL SENSORS"](#).

CAUTION:

Do not pull on wheel sensor harness.

- Loosen steering outer socket (1) nut.
- Remove steering outer socket (1) from steering knuckle (2) so as not to damage ball joint (3) boot using ball joint remover or suitable tool.

CAUTION:

Temporarily leave the outer socket nut installed to prevent damage to threads and to prevent the ball joint remover or suitable tool from suddenly coming off.

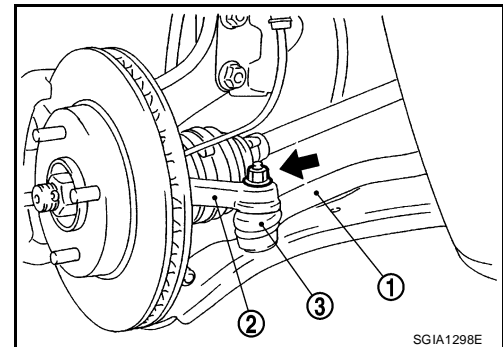

- Remove transverse link ball joint nut and bolt. Then, remove transverse link from steering knuckle.
- Remove cotter pin, then loosen hub lock nut using power tool.

CAUTION:

Temporarily leave the hub lock nut installed to prevent damage to threads.

- Separate the drive shaft from the wheel hub and bearing assembly by lightly tapping the end of the drive shaft using a hammer or suitable tool, and then remove hub lock nut.

NOTE:

Use a suitable puller if wheel hub and bearing assembly and drive shaft cannot be separated after performing the above procedure.

- Remove the drive shaft from the wheel hub and bearing assembly and support the drive shaft.

CAUTION:

- Do not apply an excessive angle to drive shaft joint when removing from the wheel hub and bearing assembly,
- Do not excessively extend slide joint.
- Do not allow drive shaft to hang down. Support the entire drive shaft.

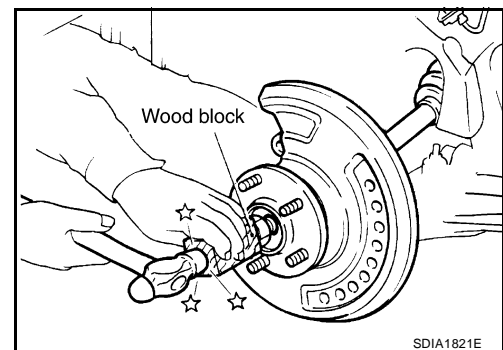

- Remove wheel hub and bearing assembly bolts, and then remove splash guard and wheel hub and bearing assembly from steering knuckle.

FRONT WHEEL HUB AND KNUCKLE

12. Remove nuts and bolts, and then remove steering knuckle from strut assembly. Refer to [FAX-5, "COMPONENT"](#) .

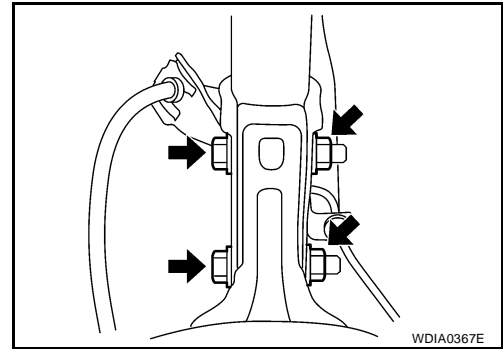

INSPECTION AFTER REMOVAL

Wheel Hub and Knuckle Inspection

Check for any deformity, cracks, or other damage on the wheel hub assembly and knuckle, replace if necessary.

CAUTION:

The wheel hub assembly does not require maintenance. If any of the following symptoms are noted, replace the wheel hub assembly.

- Growling noise is emitted from the wheel hub bearing during operation.
- Wheel hub bearing drags or turns roughly.

Ball Joint Inspection

Check boots of transverse link and steering outer socket ball joint for breakage, axial play, and torque. Refer to [FSU-14, "INSPECTION AFTER REMOVAL"](#) transverse link and [PS-14, "INSPECTION AFTER DISASSEMBLY"](#) steering outer socket ball joint.

INSTALLATION

Installation is the reverse order of removal. Note the following:

- Perform the final tightening of each of parts under unladen conditions, which were removed when removing wheel hub and bearing assembly and steering knuckle. Check the wheel alignment. Refer to [RSU-2, "Precautions for Supplemental Restraint System \(SRS\) "AIR BAG" and "SEAT BELT PRE-TENSIONER" "](#)
- When installing disc rotor on wheel hub and bearing assembly, align the marks. (When not using the alignment mark, refer to [BR-28, "DISC ROTOR INSPECTION"](#) .)

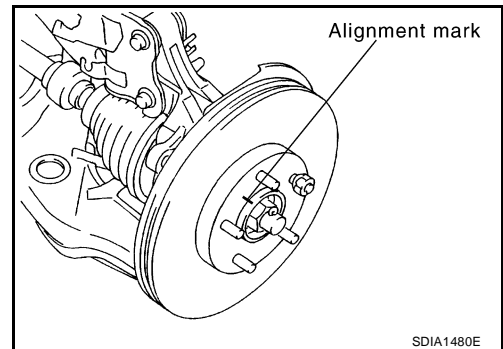

FRONT DRIVE SHAFT

FRONT DRIVE SHAFT

PF3:39100

On-Vehicle Inspection and Service

EDS003QS

- Check drive shaft mounting point and joint for looseness and other damage.
- Check boot for cracks and other damage.

Replace or repair components as necessary. Refer to [FAX-8, "Removal and Installation \(Left Side\)"](#) , [FAX-10, "Removal and Installation \(Right Side\)"](#) , [FAX-12, "Disassembly and Assembly \(Left Side\)"](#) or [FAX-18, "Disassembly and Assembly \(Right Side\)"](#) .

CAUTION:

Replace entire drive shaft assembly when noise or vibration occur from drive shaft.

Removal and Installation (Left Side)

EDS003QT

COMPONENTS

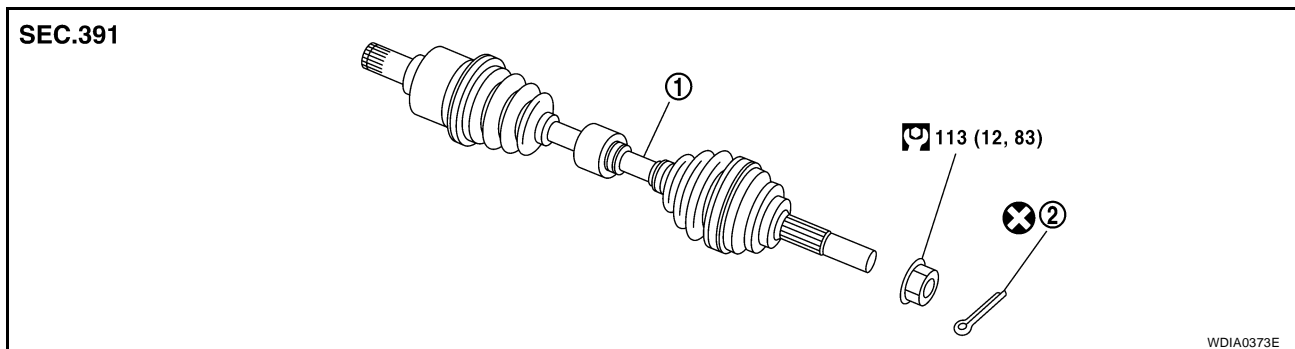

1. Drive shaft

2. Cotter pin

REMOVAL

1. Remove wheel and tire using power tool. Refer to [WT-6, "Rotation"](#) .
2. Remove wheel sensor from steering knuckle. Refer to [BRC-33, "WHEEL SENSORS"](#) .

CAUTION:

Do not pull on wheel sensor harness.

3. Remove transverse link ball joint nut and bolt. Then, remove transverse link from steering knuckle.
4. Remove cotter pin, then loosen hub lock nut using power tool.

CAUTION:

Temporarily leave the hub lock nut installed to prevent damage to threads.

5. Separate the drive shaft from the wheel hub and bearing assembly by lightly tapping the end of the drive shaft using a hammer or suitable tool and wood block, and then remove hub lock nut.

NOTE:

Use a suitable puller if wheel hub and bearing assembly and drive shaft cannot be separated after performing the above procedure.

6. Remove the drive shaft from the wheel hub and bearing assembly.

CAUTION:

- Do not apply an excessive angle to drive shaft joint when removing from the wheel hub and bearing assembly,
- Do not excessively extend slide joint.
- Do not allow drive shaft to hang down. Support the entire drive shaft.

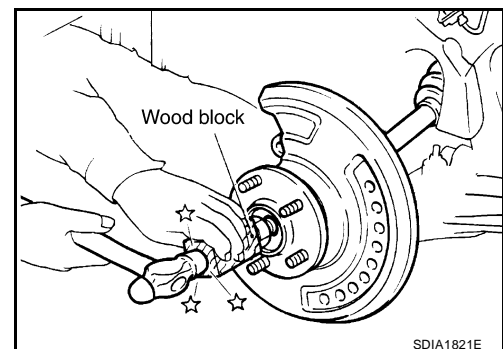

FRONT DRIVE SHAFT

7. Pry off drive shaft from transaxle assembly side as shown.

- Make sure that circlip is attached on the edge.

CAUTION:

- Do not apply an excessive angle to drive shaft joint when removing from the transaxle.
- Do not excessively extend slide joint.
- Do not allow drive shaft to hang down. Support the entire drive shaft.

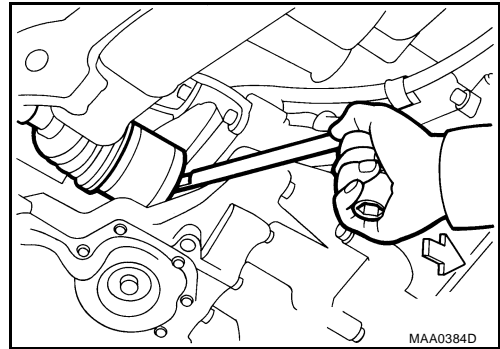

INSPECTION AFTER REMOVAL

- Move joint up/down, left/right, and in axial direction. Check for any rough movement or significant looseness.
- Check boot for cracks or other damage, and for grease leakage.
- If damaged, disassemble drive shaft to verify damage, and repair or replace as necessary.

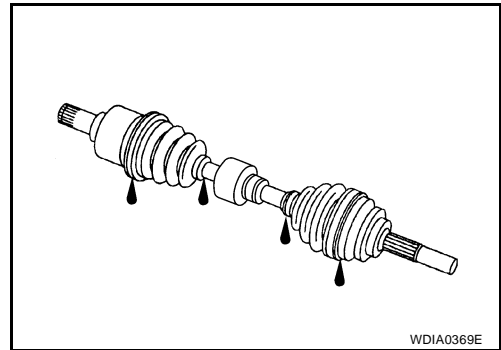

INSTALLATION

Installation is in the reverse order of removal. Note the following:

- Refer to [FAX-8, "COMPONENTS"](#) for tightening torque.

CAUTION:

Do not reuse non-reusable parts.

- In order to prevent damage to differential side oil seal, place Tool onto oil seal before inserting drive shaft as shown. Slide drive shaft into slide joint and tap with a hammer to install securely.

Tool number : KV38105500 (J-33904)

- Install new circlip on drive shaft in the circlip groove on transaxle side. Refer to [FAX-12, "Disassembly and Assembly \(Left Side\)"](#).

CAUTION:

Make sure the new circlip on the drive shaft is securely fastened.

- After its insertion, try to pull the flange out of the slide joint by hand. If it pulls out, the circlip is not properly meshed with the transaxle side gear.

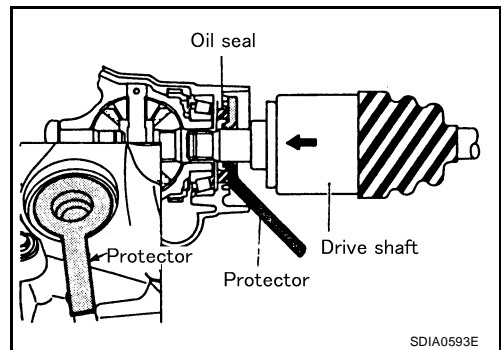

A
B
C

FAX

E
F
G
H

I
J
K
L
M

FRONT DRIVE SHAFT

Removal and Installation (Right Side) COMPONENTS

EDS003TD

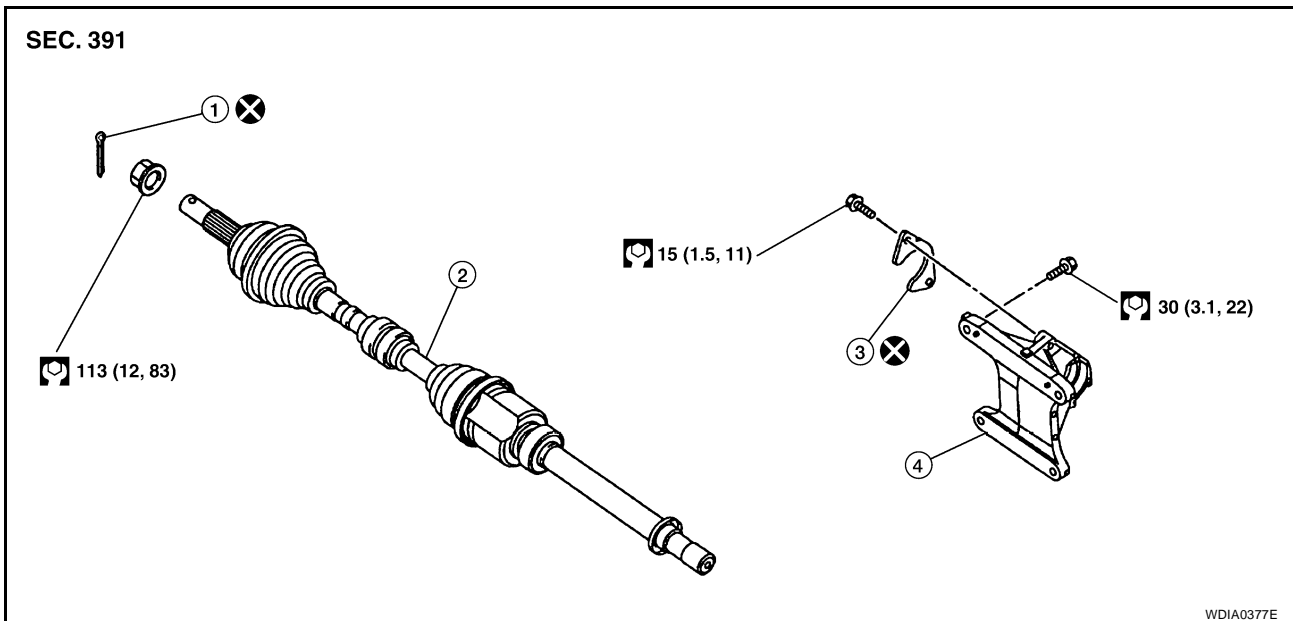

1. Cotter pin
2. Drive shaft
3. Plate
4. Support bearing bracket

REMOVAL

1. Remove wheel and tire using power tool. Refer to [WT-6, "Rotation"](#) .
2. Remove wheel sensor from steering knuckle. Refer to [BRC-33, "WHEEL SENSORS"](#) .

CAUTION:

Do not pull on wheel sensor harness.

3. Remove transverse link ball joint nut and bolt. Then, remove transverse link from steering knuckle.
4. Remove cotter pin, then loosen hub lock nut using power tool.

CAUTION:

Temporarily leave the hub lock nut installed to prevent damage to threads.

5. Separate the drive shaft from the wheel hub and bearing assembly by lightly tapping the end of the drive shaft using a hammer or suitable tool and wood block, and then remove hub lock nut.

NOTE:

Use a suitable puller if wheel hub and bearing assembly and drive shaft cannot be separated after performing the above procedure.

6. Remove the drive shaft from the wheel hub and bearing assembly.

CAUTION:

- Do not apply an excessive angle to drive shaft joint when removing from the wheel hub and bearing assembly,
- Do not excessively extend slide joint.
- Do not allow drive shaft to hang down. Support the entire drive shaft.

7. Remove the plate bolts and plate.
8. Remove the drive shaft from the transaxle assembly.

CAUTION:

- Do not apply an excessive angle to drive shaft joint when removing from the transaxle.
- Do not excessively extend slide joint.
- Do not allow drive shaft to hang down. Support the entire drive shaft.

9. If necessary, remove the support bearing bracket bolts and the support bearing bracket.

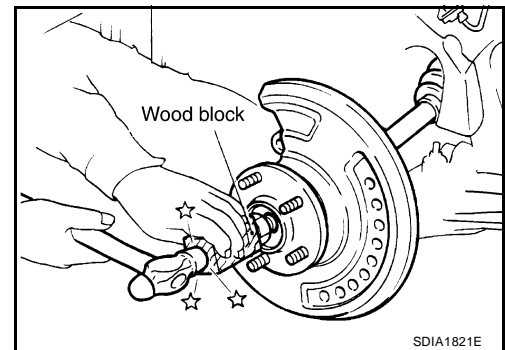

FRONT DRIVE SHAFT

INSPECTION AFTER REMOVAL

- Move joint up/down, left/right, and in axial direction. Check for any rough movement or significant looseness.
- Check boot for cracks or other damage, and for grease leakage.
- If damaged, disassemble drive shaft to verify damage, and repair or replace as necessary.
- Check for cracks or other damage to the support bearing bracket, replace as necessary.

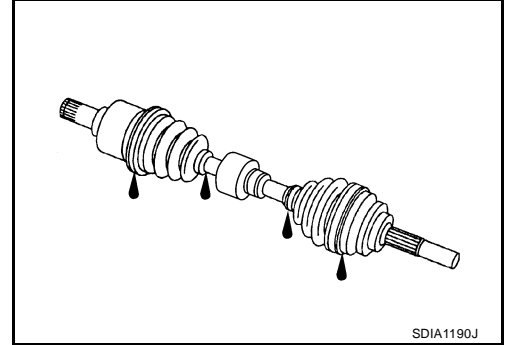

INSTALLATION

Installation is in the reverse order of removal. Note the following:

- Refer to [FAX-10, "COMPONENTS"](#) for tightening torque.

CAUTION:

Do not reuse non-reusable parts.

- In order to prevent damage to differential side oil seal, place Tool onto oil seal before inserting drive shaft as shown. Slide drive shaft into slide joint and tap with a hammer to install securely.

Tool number : KV38106700 (J-34296)

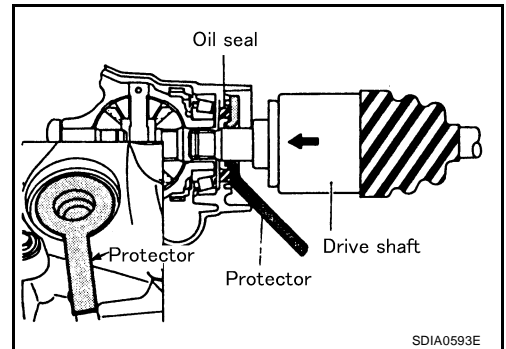

- When installing the support bearing bracket (1), note the following:
 - a. Tighten the support bearing bracket bolts in two stages, in the order as shown.
 - b. Install the plate (2) with the notch (A) upward. Tighten the plate bolts in two stages, in the order as shown.

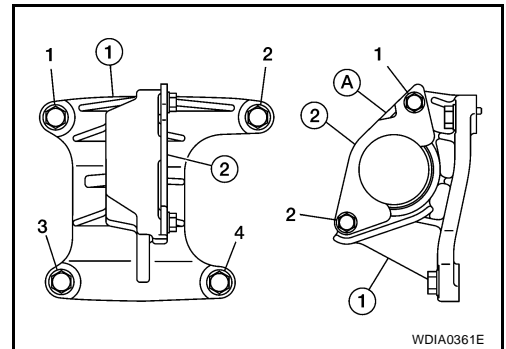

FRONT DRIVE SHAFT

Disassembly and Assembly (Left Side)

EDS003TE

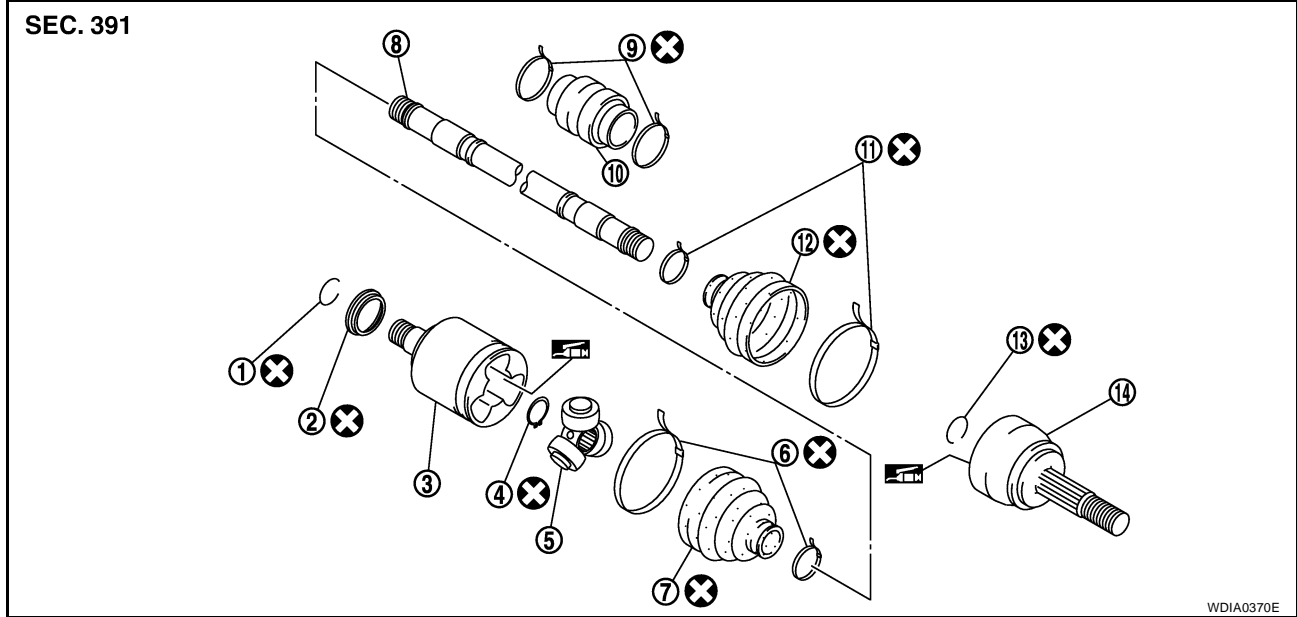

- | | | |
|--------------|------------------------|------------------------|
| 1. Circlip | 2. Dust shield | 3. Slide joint housing |
| 4. Snap ring | 5. Spider assembly | 6. Boot band |
| 7. Boot | 8. Shaft | 9. Damper band |
| 10. Damper | 11. Boot band | 12. Boot |
| 13. Circlip | 14. Joint sub-assembly | |

DISASSEMBLY

Transaxle Side

1. Mount drive shaft in a vise.

CAUTION:

When mounting shaft in a vise, always use copper or aluminum plates between vise and shaft.

2. Remove boot bands and slide the boot back.
3. Remove circlip and dust shield from slide joint housing.
4. Put matching marks on slide joint housing and shaft, then pull out shaft from slide joint housing.
5. Put matching marks on spider assembly and shaft.

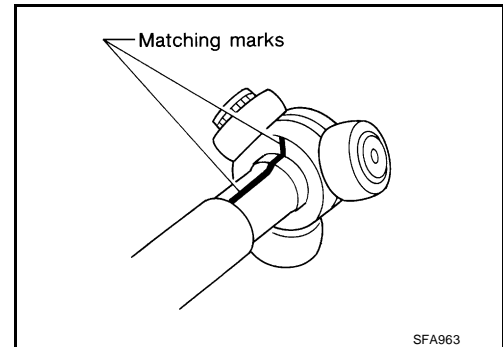

FRONT DRIVE SHAFT

6. Remove snap ring using a suitable tool, then remove spider assembly from shaft.
7. Remove boot from shaft.
8. Clean the old grease off of the slide joint assembly.

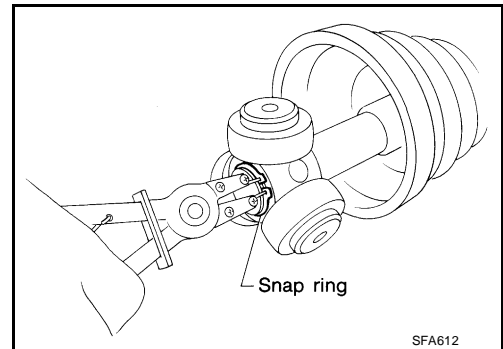

Wheel Side

1. Mount the front drive shaft in a vise.

CAUTION:

When mounting shaft in a vise, always use copper or aluminum plates between vise and shaft.

2. Remove boot bands and slide the boot back.
3. Screw a sliding hammer or suitable tool 30 mm (1.18 in) or more into threaded part of joint sub-assembly. Pull joint sub-assembly out of shaft.

CAUTION:

- Align sliding hammer or suitable tool and drive shaft then remove joint sub-assembly by pulling directly.
- If joint sub-assembly cannot be removed after five or more unsuccessful attempts, replace the entire drive shaft assembly.

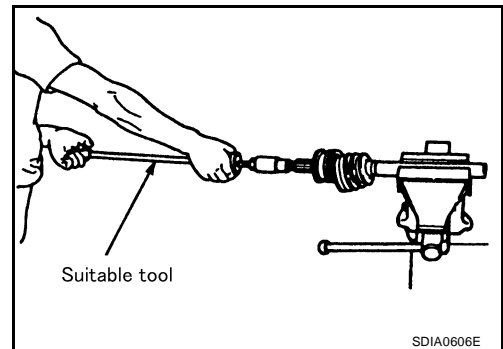

4. Remove circlip from shaft.
5. Remove boot from shaft.
6. While rotating ball cage, clean the old grease off of the joint sub-assembly.

Damper

- Remove damper bands, then remove damper from shaft.

INSPECTION AFTER DISASSEMBLY

Shaft

Replace shaft if there is bending, cracking, or other damage.

Joint Sub-Assembly

- Make sure there is no rough rotation or unusual axial looseness.
- Make sure there is no foreign material inside joint sub-assembly.
- Check joint sub-assembly for compression scars, cracks or fractures.

CAUTION:

If there are any irregular conditions of joint sub-assembly components, replace the entire joint sub-assembly.

Slide Joint Housing and Spider Assembly

Make sure there are no compression scars, cracks, fractures or unusual wear of housing or spider roller contact surface.

CAUTION:

If there are any irregular conditions of the slide joint housing and spider assembly components, replace them as a set.

Damper

Check damper for cracks or wear. Replace as necessary.

FRONT DRIVE SHAFT

ASSEMBLY

Transaxle Side

1. Install new boot and new small boot band on shaft.

CAUTION:

- Do not reuse boot or boot band.
- Cover drive shaft serration with tape to prevent damage to boot during installation.

2. Remove protective tape wound around serrated part of shaft.

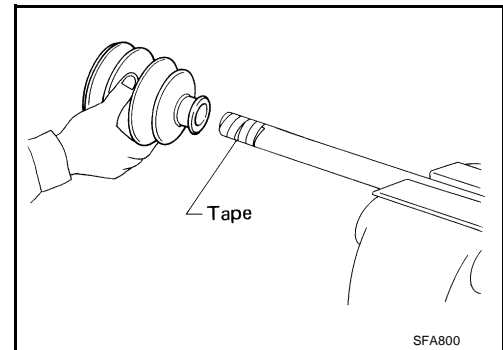

3. Align matching mark on spider assembly with matching mark on shaft and install spider assembly with chamfer facing shaft.

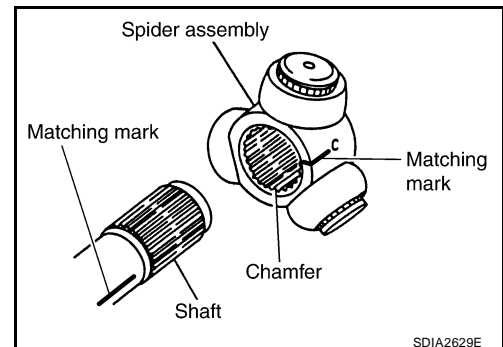

4. Install new snap ring using a suitable tool.

CAUTION:

Do not reuse snap ring.

5. Apply recommended grease (Genuine NISSAN Grease or equivalent) to spider assembly and sliding surface.
6. Install the slide joint housing onto the spider assembly and pack with the balance of recommended grease (Genuine NISSAN Grease or equivalent).

Grease amount : 130 – 140 g (4.6 – 4.9 oz)

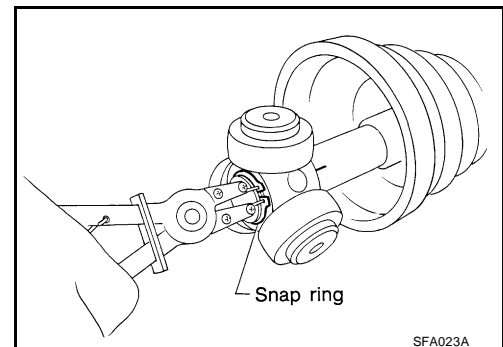

7. Install boot securely into grooves (indicated by * marks) as shown.

CAUTION:

If there is grease on boot mounting surfaces (indicated by * marks) of shaft and housing, boot may come off. Clean all grease from surfaces.

8. Make sure boot installation length "L" is the length specified below. Insert a flat-bladed screwdriver or similar tool into the large end of boot. Bleed air from boot to prevent boot deformation.

Boot installation length "L"

M/T models : 181.2 mm (7.13 in)

Except for M/T models : 176.0 mm (6.93 in)

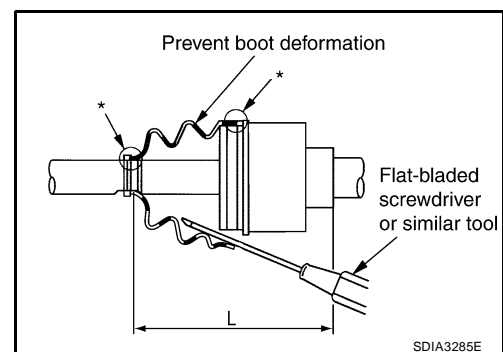

CAUTION:

- Boot may break if boot installation length is outside the standard value.
- Be careful that screwdriver tip does not contact inside surface of boot.

9. Secure large end of boot with new boot band.

1. Set boot band onto boot and insert first pawl on boot band into the first groove on opposite end of boot band.

FRONT DRIVE SHAFT

2. Pull and tighten the boot band using suitable tool until both pawls of boot band are secured in the boot band grooves.

CAUTION:

Do not reuse boot band.

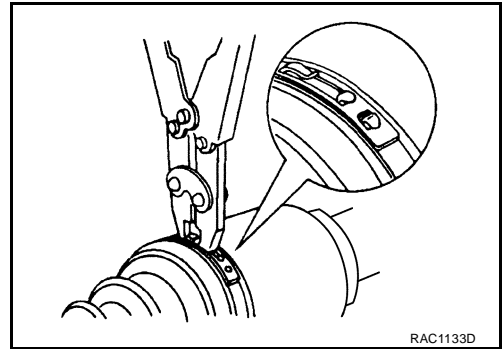

10. Install new small boot band securely using Tool.

Tool number : KV40107300 (—)

CAUTION:

- Do not reuse boot band.
- Secure boot band so that dimension "M" meets specification as shown.

Dimension "M" : 1.0 – 4.0 mm (0.039 – 0.157 in)

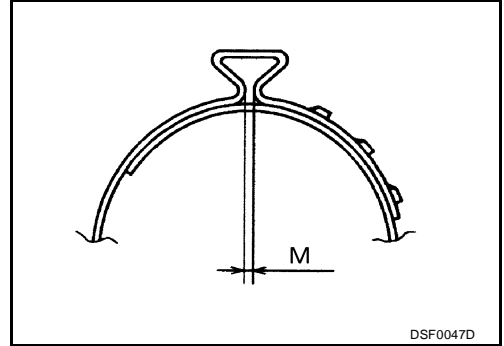

11. Rotate the slide joint and confirm that the boot position is correct. If boot position is not correct, remove the boot bands, reposition the boot and install new boot bands.
12. Install new dust shield to slide joint housing.

CAUTION:

Do not reuse dust shield.

Wheel Side

1. Insert recommended grease (Genuine NISSAN Grease or equivalent) into joint sub-assembly serration hole until grease begins to ooze from ball groove and serration hole. After inserting grease, use a shop cloth to wipe off old grease that has oozed out.

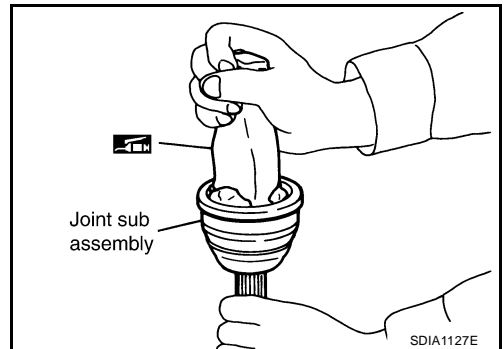

2. Cover serrated part of shaft with tape. Install new boot band and new boot to shaft.

CAUTION:

Do not reuse boot or boot band.

3. Remove protective tape wound around serrated part of shaft.

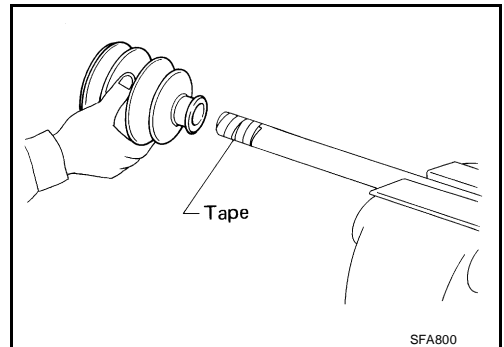

A
B
C
FAX
E
F
G
H
I
J
K
L
M

FRONT DRIVE SHAFT

- Attach new circlip to shaft. Thread nut onto end of joint sub-assembly and press fit using suitable tool.

CAUTION:

- Do not reuse circlip.
- Circlip must fit securely into shaft groove.

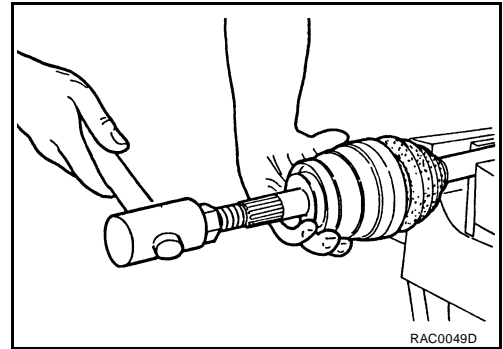

- Insert the balance of new grease (Genuine NISSAN Grease or equivalent) listed below into housing from large end of boot.

Grease amount : 70 – 90 g (2.5 – 3.2 oz)

- Install boot securely into grooves (indicated by * marks) as shown.

CAUTION:

If there is grease on boot mounting surfaces (indicated by * marks) of shaft and housing, boot may come off. Remove all grease from surfaces.

- Make sure boot installation length "L" is the specified length indicated below. Insert a flat-bladed screwdriver or similar tool into the large end of boot. Bleed air from boot to prevent boot deformation.

Boot installation length "L" : 142 mm (5.59 in)

CAUTION:

- Boot may break if boot installation length is outside the standard value.
- Be careful that screwdriver tip does not contact inside surface of boot.

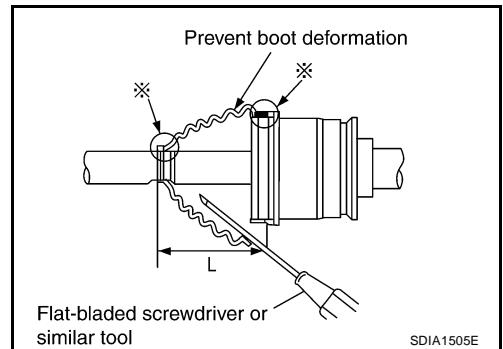

- Install new large and small boot bands securely using Tool.

Tool number : KV40107300 (—)

CAUTION:

- Do not reuse boot bands.

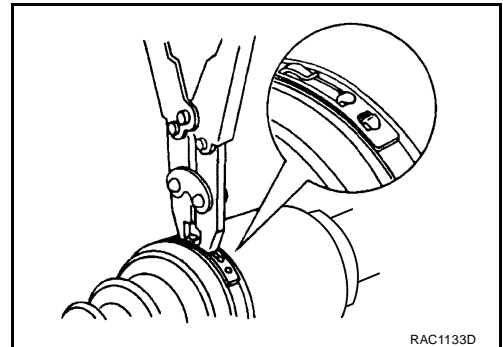

- Secure boot band so that dimension "M" meets specification as shown.

Dimension "M" : 1.0 – 4.0 mm (0.039 – 0.157 in)

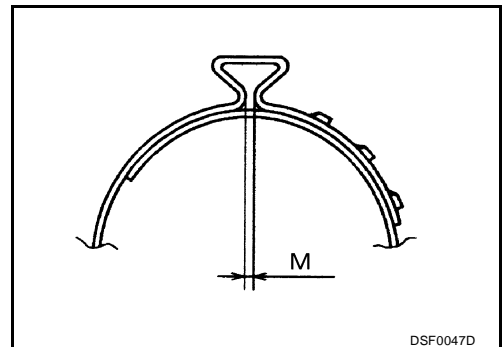

- Rotate the joint sub assembly and confirm that the boot position is correct. If boot position is not correct, remove the boot bands, reposition the boot and install new boot bands.

FRONT DRIVE SHAFT

Damper

1. Secure damper with new damper bands.

"A"	Except for CVT models	: 230 – 236 mm (9.06 – 9.29 in)
	CVT models	: 225 – 231 mm (8.86 – 9.09 in)
"B"		: 70 mm (2.76 in)

CAUTION:

Do not reuse damper bands.

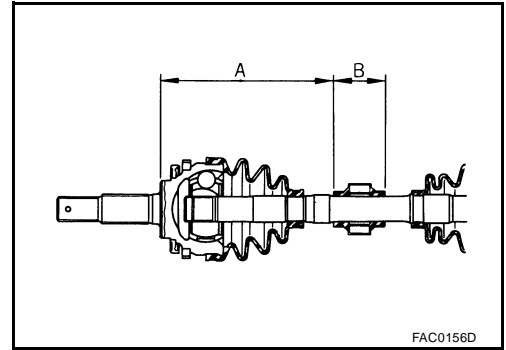

A

B

C

FAX

E

F

G

H

I

J

K

L

M

FRONT DRIVE SHAFT

Disassembly and Assembly (Right Side)

EDS003TF

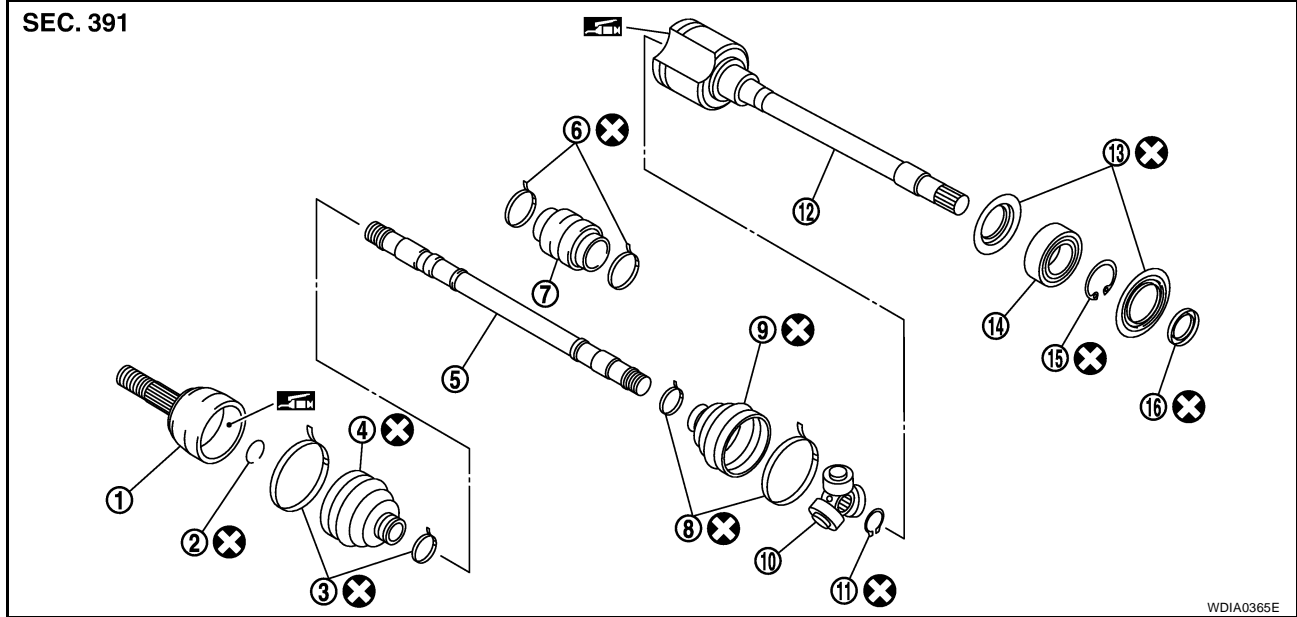

- | | | |
|-----------------------|---------------|-------------------------|
| 1. Joint sub-assembly | 2. Circlip | 3. Boot bands |
| 4. Boot | 5. Shaft | 6. Damper bands |
| 7. Damper | 8. Boot band | 9. Boot |
| 10. Spider assembly | 11. Snap ring | 12. Slide joint housing |
| 13. Dust shield | 14. Bearing | 15. Snap ring |
| 16. Dust shield | | |

DISASSEMBLY

Transaxle Side

1. Mount drive shaft in a vise.

CAUTION:

When mounting shaft in a vise, always use copper or aluminum plates between vise and shaft.

2. Remove boot bands and slide the boot back.
3. Put matching marks on slide joint housing and shaft, then pull out shaft from slide joint housing.
4. Put matching marks on spider assembly and shaft.

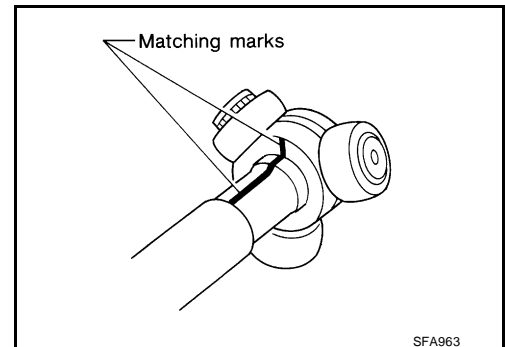

SFA963

FRONT DRIVE SHAFT

5. Remove snap ring using a suitable tool, then remove spider assembly from shaft.
6. Remove boot from shaft.
7. Clean the old grease off of the slide joint assembly.

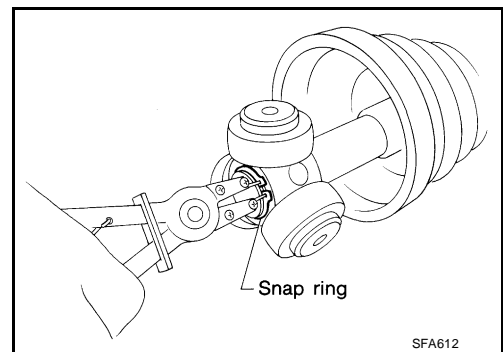

Wheel Side

1. Mount the front drive shaft in a vise.

CAUTION:

When mounting shaft in a vise, always use copper or aluminum plates between vise and shaft.

2. Remove boot bands and slide the boot back.
3. Screw a sliding hammer or suitable tool 30 mm (1.18 in) or more into threaded part of joint sub-assembly. Pull joint sub-assembly out of shaft.

CAUTION:

- Align sliding hammer or suitable tool and drive shaft then remove joint sub-assembly by pulling directly.
- If joint sub-assembly cannot be removed after five or more unsuccessful attempts, replace the entire drive shaft assembly.

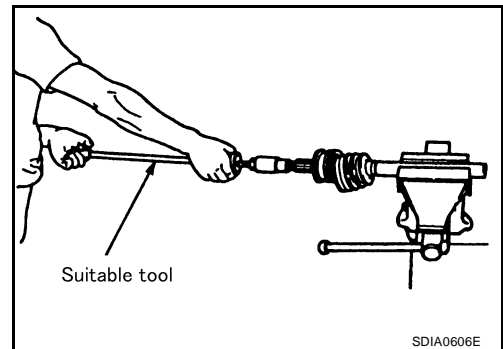

4. Remove circlip from shaft.
5. Remove boot from shaft.
6. While rotating ball cage, clean the old grease off of the joint sub-assembly.

Support Bearing

1. Remove dust shield from slide joint assembly using a suitable tool.

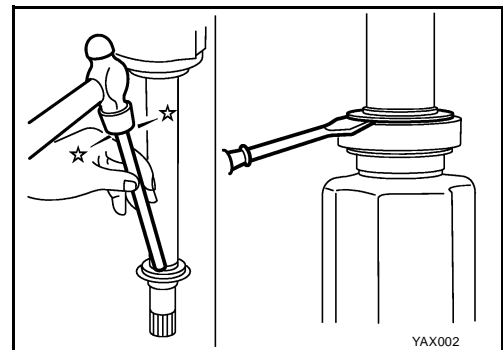

2. Remove dust shield, then remove snap ring using a suitable tool.

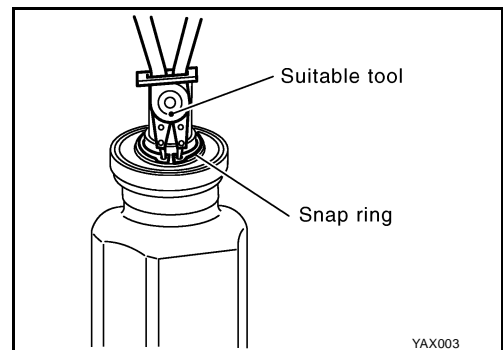

FRONT DRIVE SHAFT

3. Press support bearing assembly off slide joint assembly using a suitable tool.
4. Remove dust shield.

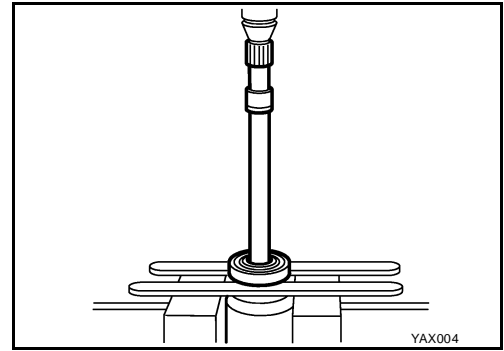

Damper

- Remove damper bands, then remove damper from shaft.

INSPECTION AFTER DISASSEMBLY

Shaft

Replace shaft if there is bending, cracking, or other damage.

Joint Sub-Assembly

- Make sure there is no rough rotation or unusual axial looseness.
- Make sure there is no foreign material inside joint sub-assembly.
- Check joint sub-assembly for compression scars, cracks or fractures.

CAUTION:

If there are any irregular conditions of joint sub-assembly components, replace the entire joint sub-assembly.

Slide Joint Housing and Spider Assembly

Make sure there are no compression scars, cracks, fractures or unusual wear of housing or spider roller contact surface.

CAUTION:

If there are any irregular conditions of the slide joint housing and spider assembly components, replace them as a set.

Support Bearing

Make sure wheel bearing rolls freely and is free from noise, cracks, pitting or wear.

Support Bearing Bracket

Check for bending, cracks, or damage.

Damper

Check damper for cracks or wear. Replace as necessary.

ASSEMBLY

Transaxle Side

1. Install new boot and new small boot band on shaft.

CAUTION:

- Do not reuse boot or boot band.
 - Cover drive shaft serration with tape to prevent damage to boot during installation.
2. Remove protective tape wound around serrated part of shaft.

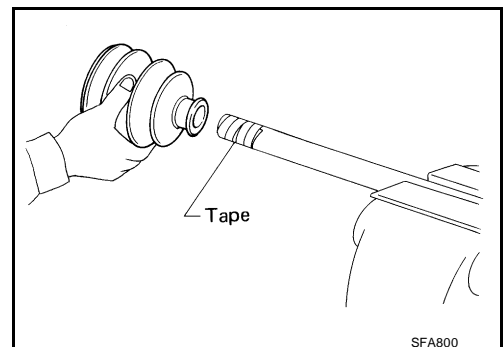

FRONT DRIVE SHAFT

3. Align matching mark on spider assembly with matching mark on shaft and install spider assembly with chamfer facing shaft.

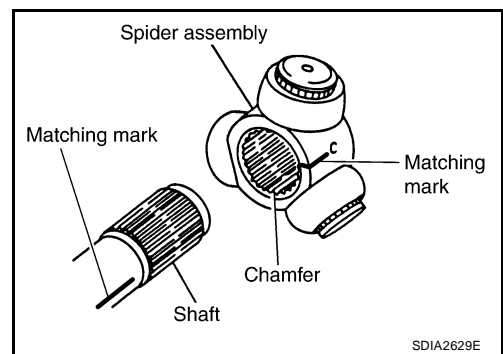

4. Install new snap ring using a suitable tool.

CAUTION:

Do not reuse snap ring.

5. Apply recommended grease (Genuine NISSAN Grease or equivalent) to spider assembly and sliding surface.
6. Install the slide joint housing onto the spider assembly and pack with the balance of recommended grease (Genuine NISSAN Grease or equivalent).

Grease amount : 130 – 140 g (4.6 – 4.9 oz)

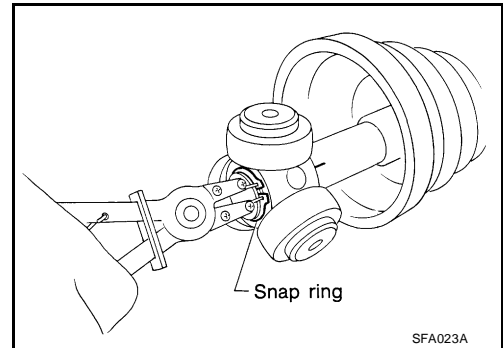

7. Install boot securely into grooves (indicated by * marks) as shown.

CAUTION:

If there is grease on boot mounting surfaces (indicated by * marks) of shaft and housing, boot may come off. Clean all grease from surfaces.

8. Make sure boot installation length "L" is the length specified below. Insert a flat-bladed screwdriver or similar tool into the large end of boot. Bleed air from boot to prevent boot deformation.

Boot installation length "L"

A/T models : 178 mm (7.01 in)

Except for A/T models : 168 mm (6.61 in)

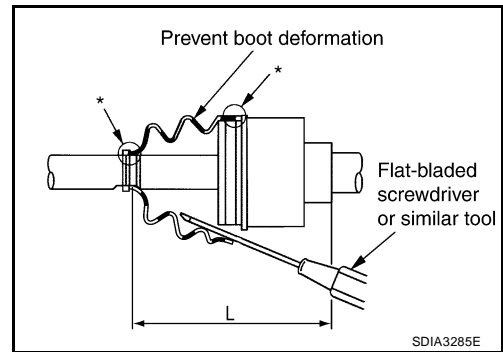

CAUTION:

- **Boot may break if boot installation length is outside the standard value.**
- **Be careful that screwdriver tip does not contact inside surface of boot.**

9. Secure large end of boot with new boot band.

1. Set boot band onto boot and insert first pawl on boot band into the first groove on opposite end of boot band.
2. Pull and tighten the boot band using suitable tool until both pawls of boot band are secured in the boot band grooves.

CAUTION:

Do not reuse boot band.

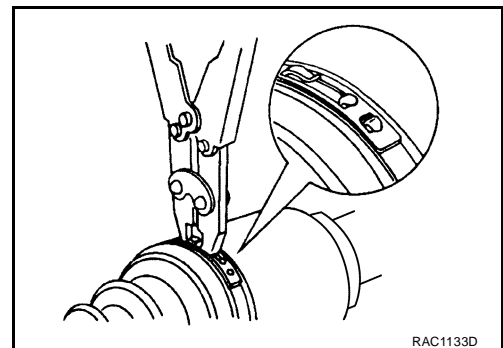

FRONT DRIVE SHAFT

10. Install new small boot band securely using Tool.

Tool number : KV40107300 (—)

CAUTION:

- Do not reuse boot band.
- Secure boot band so that dimension “M” meets specification as shown.

Dimension “M” : 1.0 – 4.0 mm (0.039 – 0.157 in)

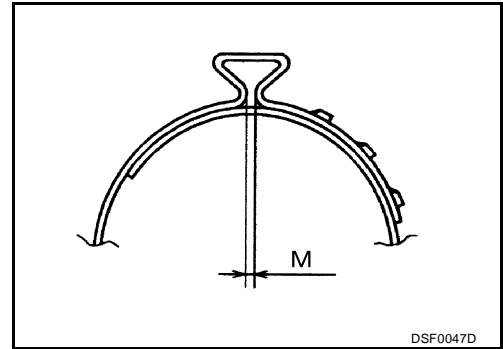

11. Rotate the slide joint and confirm that the boot position is correct. If boot position is not correct, remove the boot bands, reposition the boot and install new boot bands.

Wheel Side

1. Insert recommended grease (Genuine NISSAN Grease or equivalent) into joint sub-assembly serration hole until grease begins to ooze from ball groove and serration hole. After inserting grease, use a shop cloth to wipe off old grease that has oozed out.

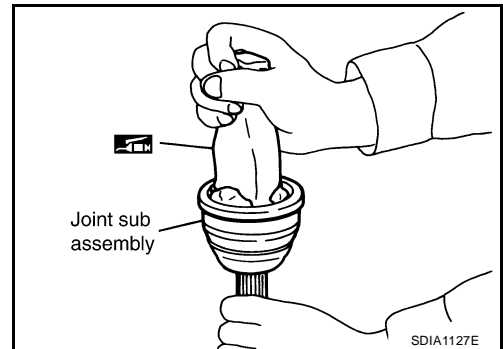

2. Cover serrated part of shaft with tape. Install new boot band and new boot to shaft.

CAUTION:

Do not reuse boot or boot band.

3. Remove protective tape wound around serrated part of shaft.

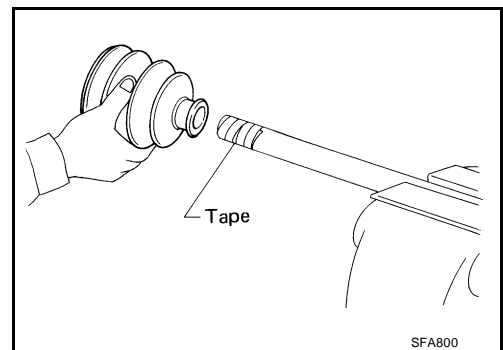

4. Attach new circlip to shaft. Thread nut onto end of joint sub-assembly and press fit using suitable tool.

CAUTION:

- Do not reuse circlip.
- Circlip must fit securely into shaft groove.

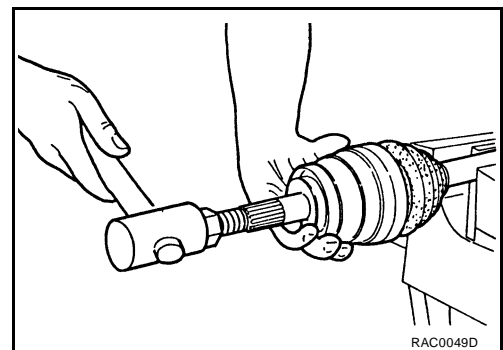

5. Insert the balance of new grease (Genuine NISSAN Grease or equivalent) listed below into housing from large end of boot.

Grease amount : 70 – 90 g (2.5 – 3.2 oz)

FRONT DRIVE SHAFT

- Install boot securely into grooves (indicated by * marks) as shown.

CAUTION:

If there is grease on boot mounting surfaces (indicated by * marks) of shaft and housing, boot may come off. Remove all grease from surfaces.

- Make sure boot installation length "L" is the specified length indicated below. Insert a flat-bladed screwdriver or similar tool into the large end of boot. Bleed air from boot to prevent boot deformation.

Boot installation length "L" : 142 mm (5.59 in)

CAUTION:

- Boot may break if boot installation length is outside the standard value.
- Be careful that screwdriver tip does not contact inside surface of boot.

- Install new large and small boot bands securely using Tool.

Tool number : KV40107300 (—)

CAUTION:

- Do not reuse boot bands.

- Secure boot band so that dimension "M" meets specification as shown.

Dimension "M" : 1.0 – 4.0 mm (0.039 – 0.157 in)

- Rotate the joint sub assembly and confirm that the boot position is correct. If boot position is not correct, remove the boot bands, reposition the boot and install new boot bands.

Support Bearing

- Install new dust shield on drive shaft

CAUTION:

Do not reuse dust shield.

- Press support bearing onto drive shaft.

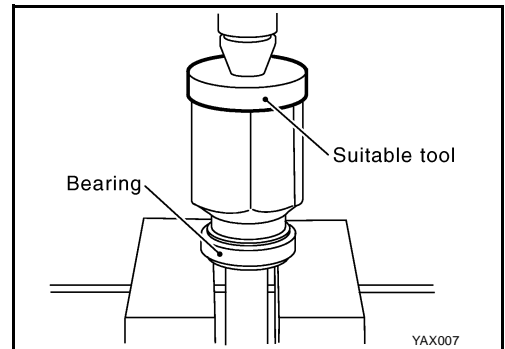
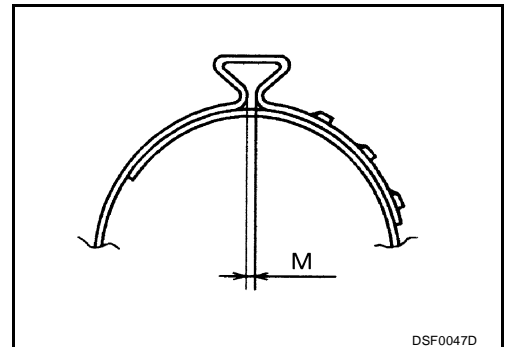
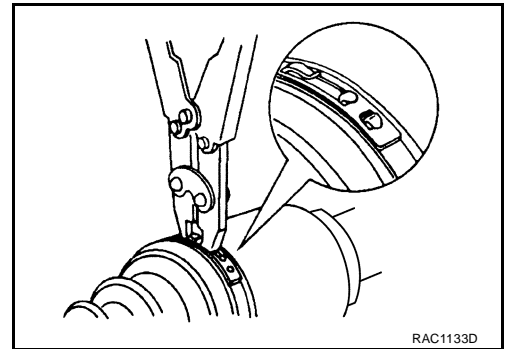
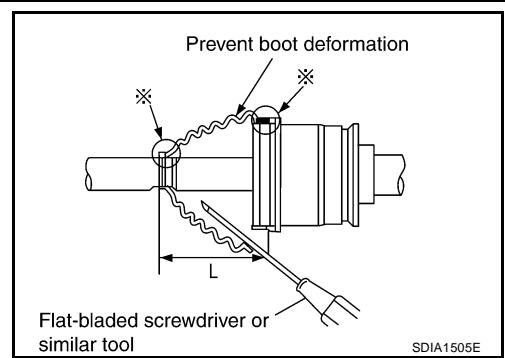

A
B
C
FAX
E
F
G
H
I
J
K
L
M

FRONT DRIVE SHAFT

3. Install new snap ring.

CAUTION:
Do not reuse snap ring.

4. Install new dust shield

CAUTION:
Do not reuse dust shield.

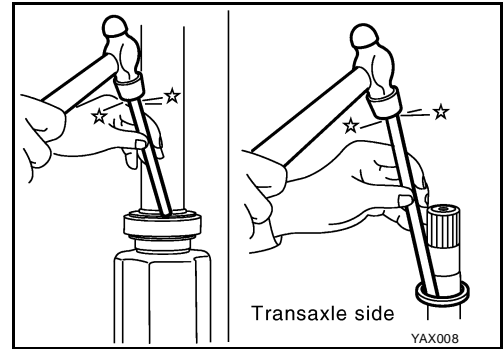

Damper

1. Secure damper with new damper bands.

"A"	Except for CVT models	: 230 – 236 mm (9.06 – 9.29 in)
	CVT models	: 225 – 231 mm (8.86 – 9.09 in)
"B"		: 70 mm (2.76 in)

CAUTION:
Do not reuse damper bands.

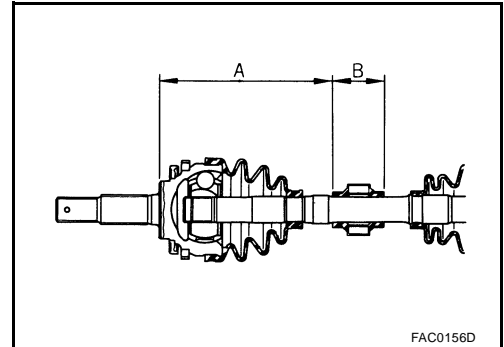

SERVICE DATA AND SPECIFICATIONS (SDS)

SERVICE DATA AND SPECIFICATIONS (SDS)

PFP:00030

Drive Shaft

EDS003QW

Joint type		Wheel side	Transaxle side
Grease quantity		70 - 90 g (2.5 - 3.2 oz)	130 - 140 g (4.6 - 4.9 oz)
Boots installed length	Left side	142 mm (5.59 in)	181.2 mm (7.13 in) (M/T models) 176 mm (6.93 in) (Except for M/T models)
	Right side		178 mm (7.01 in) (A/T models) 168 mm (6.61 in) (Except for A/T models)

Dynamic Damper

EDS003QX

Dimension A	Except for CVT models	230 - 236 mm (9.06 - 9.29 in)
	CVT models	225 - 231 mm (8.86 - 9.09 in)
Dimension B		70 mm (2.76 in)

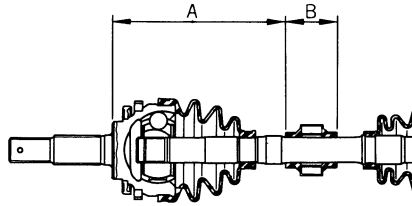

FAC0156D

SERVICE DATA AND SPECIFICATIONS (SDS)
