

SECTION **CL**
CLUTCH

A
B
CL
D
E
F
G
H
I
J
K
L
M

CONTENTS

PRECAUTIONS	2	CSC (CONCENTRIC SLAVE CYLINDER)	11
Precautions for Supplemental Restraint System (SRS) "AIR BAG" and "SEAT BELT PRE-TENSIONER"	2	Removal and Installation	11
Service Notice or Precautions	2	REMOVAL	11
PREPARATION	3	INSTALLATION	11
Special Service Tools	3	CLUTCH PIPING	12
Commercial Service Tools	3	Removal and Installation	12
NOISE, VIBRATION AND HARSHNESS (NVH)		REMOVAL	12
TROUBLESHOOTING	4	INSTALLATION	12
NVH Troubleshooting Chart	4	CLUTCH DISC, CLUTCH COVER AND FLYWHEEL..	13
CLUTCH PEDAL	5	Removal and Installation	13
On-vehicle Inspection and Adjustment	5	COMPONENTS	13
Removal and Installation	7	REMOVAL	13
COMPONENTS	7	INSPECTION AND ADJUSTMENT AFTER	
REMOVAL	7	REMOVAL	13
INSPECTION AFTER REMOVAL	7	INSTALLATION	14
INSTALLATION	7	SERVICE DATA AND SPECIFICATIONS (SDS)	16
CLUTCH FLUID	8	Clutch Control System	16
Air Bleeding Procedure	8	Clutch Pedal	16
CLUTCH MASTER CYLINDER	9	Clutch Disc	16
Removal and Installation	9	Clutch Cover	16
REMOVAL	9		
INSTALLATION	9		

PRECAUTIONS

PRECAUTIONS

PF0:00001

Precautions for Supplemental Restraint System (SRS) “AIR BAG” and “SEAT BELT PRE-TENSIONER”

ECS00GVW

The Supplemental Restraint System such as “AIR BAG” and “SEAT BELT PRE-TENSIONER”, used along with a front seat belt, helps to reduce the risk or severity of injury to the driver and front passenger for certain types of collision. This system includes seat belt switch inputs and dual stage front air bag modules. The SRS system uses the seat belt switches to determine the front air bag deployment, and may only deploy one front air bag, depending on the severity of a collision and whether the front occupants are belted or unbelted. Information necessary to service the system safely is included in the SRS and SB section of this Service Manual.

WARNING:

- To avoid rendering the SRS inoperative, which could increase the risk of personal injury or death in the event of a collision which would result in air bag inflation, all maintenance must be performed by an authorized NISSAN/INFINITI dealer.
- Improper maintenance, including incorrect removal and installation of the SRS, can lead to personal injury caused by unintentional activation of the system. For removal of Spiral Cable and Air Bag Module, see the SRS section.
- Do not use electrical test equipment on any circuit related to the SRS unless instructed to in this Service Manual. SRS wiring harnesses can be identified by yellow and/or orange harnesses or harness connectors.

Service Notice or Precautions

ECS00FST

- Use recommended brake fluid when adding fluid to the clutch reservoir tank. Refer to [MA-11, "RECOMMENDED FLUIDS AND LUBRICANTS"](#).
- Never reuse fluid drained from clutch system.
- Be careful not to splash brake fluid on painted areas.
- Use new brake fluid to clean or wash all parts of master cylinder and operating cylinder.
- Never use mineral oils such as gasoline or kerosene. It will ruin the rubber parts of the hydraulic system.
- If transaxle assembly is removed from the vehicle, always replace CSC (Concentric slave cylinder). Return CSC to original position to remove transaxle assembly. Dust on clutch disc sliding parts may damage CSC seal and may cause clutch fluid leakage.
- Do not disassemble clutch master cylinder and CSC.

WARNING:

After cleaning clutch disc, clean it with a dust collector. Do not use compressed air.

PREPARATION

PREPARATION

PF0:00002

Special Service Tools

ECS00FSU

The actual shapes of Kent-Moore tools may differ from those of special service tools illustrated here.

Tool number (Kent-Moore No.) Tool name	Description
ST20050240 (—) Diaphragm spring adjusting wrench	Adjusting unevenness of diaphragm spring of clutch cover
KV30101000 (—) Clutch aligning bar	Installing clutch cover and clutch disc a: 15.9 mm (0.626 in) dia. b: 19.8 mm (0.780 in) dia.

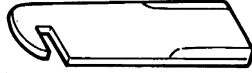

ZZA0508D

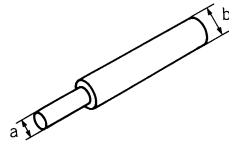

ZZA1178D

Commercial Service Tools

ECS00G57

Tool name	Description
Power tool	Loosening bolts and nuts

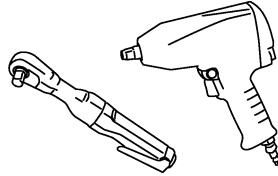

PBIC0190E

NOISE, VIBRATION AND HARSHNESS (NVH) TROUBLESHOOTING

NOISE, VIBRATION AND HARSHNESS (NVH) TROUBLESHOOTING

PF0:00003

NVH Troubleshooting Chart

ECS00FSV

Use the chart below to help you find the cause of the symptom. The numbers indicate the order of the inspection. If necessary, repair or replace these parts.

Reference page		CL-5	CL-8	EM-73	CL-11	CL-13										EM-103	
Symptom		CLUTCH PEDAL (Inspection and adjustment)	CLUTCH LINE (Air in line)	ENGINE MOUNTING (Loose)	CSC (Concentric slave cylinder) (Worn, dirty or damaged)	CLUTCH DISC (Out of true)	CLUTCH DISC (Runout is excessive)	CLUTCH DISC (Lining broken)	CLUTCH DISC (Dirty or burned)	CLUTCH DISC (Oily)	CLUTCH DISC (Worn out)	CLUTCH DISC (Hardened)	CLUTCH DISC (Lack of spline grease)	DIAPHRAGM SPRING (Damaged)	DIAPHRAGM SPRING (Out of tip alignment)	PRESSURE PLATE (Distortion)	FLYWHEEL (Distortion)
Symptom	Clutch grabs/chatters			1			2			2	2	2			2		
	Clutch pedal spongy		1														
	Clutch noisy				1												
	Clutch slips	1								2	2			3		4	5
	Clutch does not disengage	1	2			5	5	5	5	5			5	6	6	7	

CLUTCH PEDAL

PFP:46540

CLUTCH PEDAL

ECS00GVX

On-vehicle Inspection and Adjustment

1. Check to see if the master cylinder rod end floats freely. It should not be bound by the clutch pedal.
 - a. If the rod end is not free, check that the ASCD switch is not applying pressure to the clutch pedal causing the rod end to bind. To adjust, disconnect the ASCD switch electrical connector and turn the ASCD switch.
 - b. Connect the ASCD switch electrical connector.
 - c. Verify that the master cylinder rod end floats freely. It should not be bound by the clutch pedal.
 - d. If the rod end is still not free, remove the rod end and check for deformation or damage. Leave the rod end removed for step 2.
2. Check the clutch pedal stroke for free range of movement.

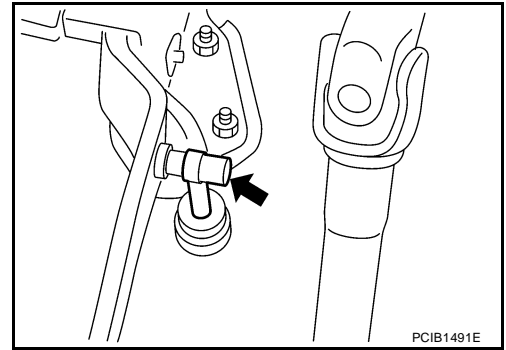

- a. With the master cylinder rod end removed, manually move the pedal up and down to determine if it moves freely.
 - b. If any sticking is noted, replace the clutch pedal assembly. Re-verify that the master cylinder rod end floats freely.
3. Adjust clutch interlock switch (1) position so that clearance between clutch pedal (2) and thread end of clutch interlock switch (1), with clutch pedal fully depressed, is within specification (C).

Clearance C : 0.74 - 1.96 mm (0.0291 - 0.0772 in)

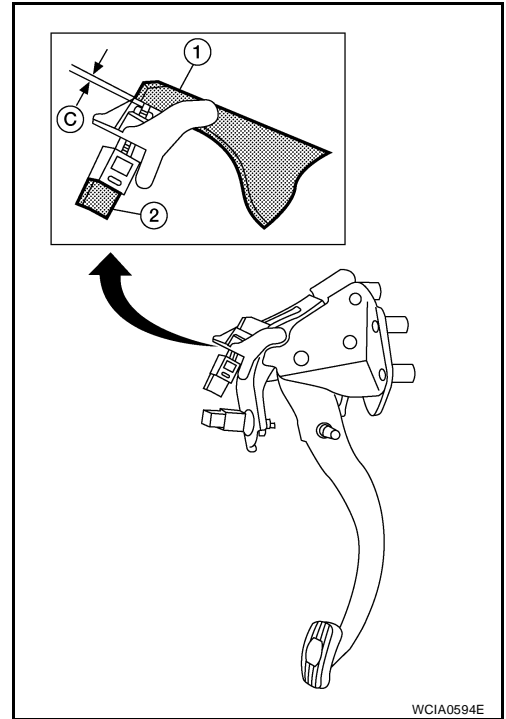

A
B
CL
D
E
F
G
H
I
J
K
L
M

CLUTCH PEDAL

4. Adjust ASCD clutch switch (1) position so that clearance between clutch pedal (2) and thread end of ASCD clutch switch (1), with clutch pedal fully released, is within specification (A).

Clearance A : 0.74 - 1.96 mm (0.0291 - 0.0772 in)

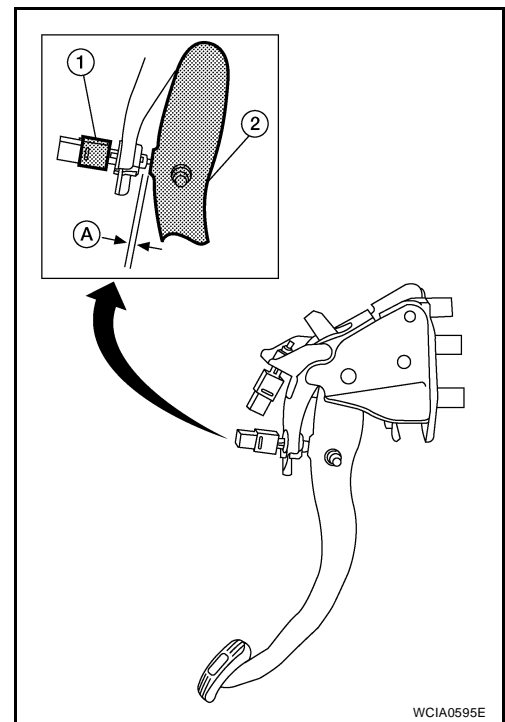

5. Check the clutch hydraulic system components (clutch master cylinder, clutch operating cylinder, clutch withdrawal lever and clutch release bearing) for sticking or binding.
 - a. If any sticking or binding is noted, repair or replace the related parts as necessary.
 - b. If any hydraulic system repair was necessary, bleed the clutch hydraulic system. Refer to [CL-8, "Air Bleeding Procedure"](#).

NOTE:

Do not use a vacuum assist or any other type of power bleeder on this system. Use of a vacuum assist or power bleeder will not purge all of the air from the system.

CLUTCH PEDAL

Removal and Installation COMPONENTS

ECS00FSX

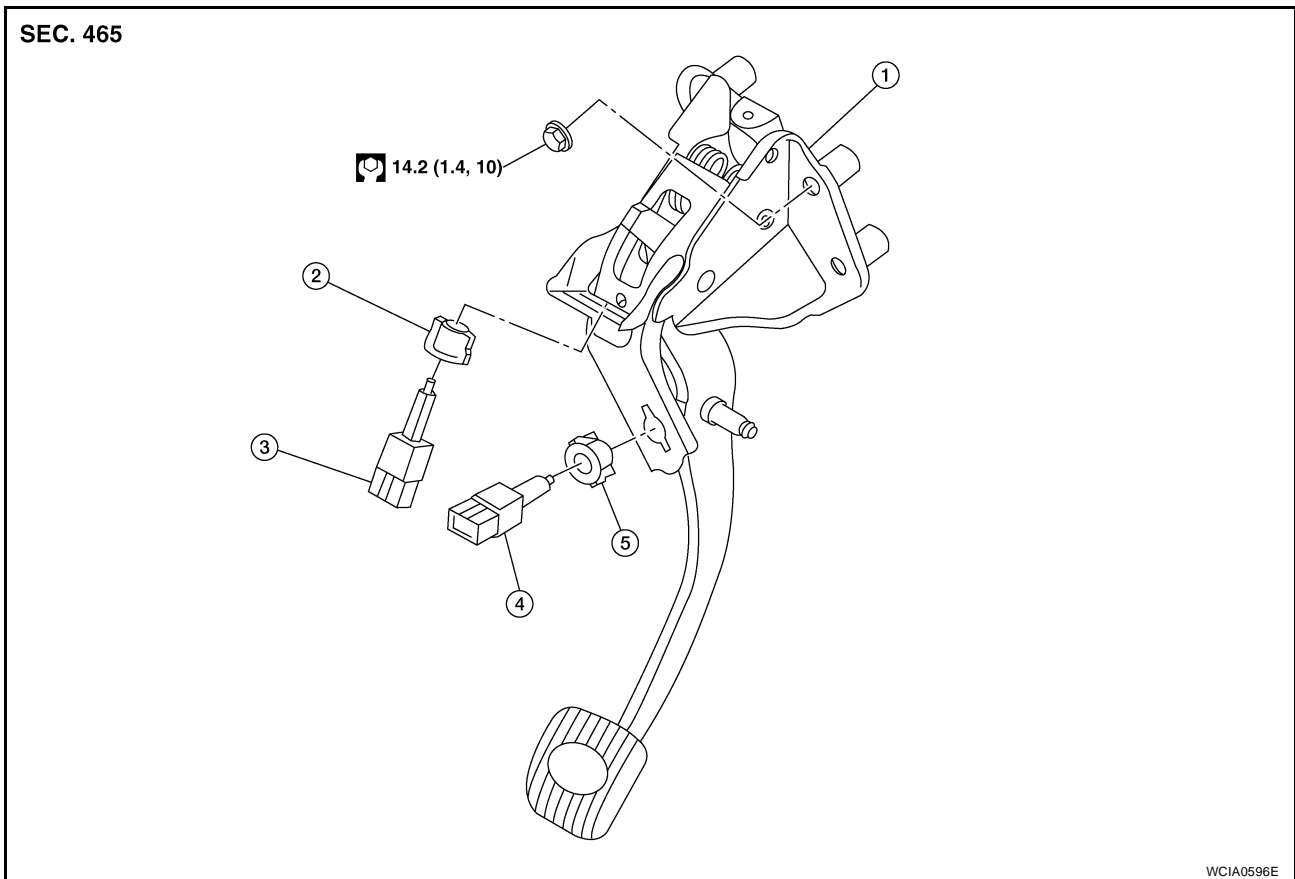

- | | | |
|--------------------------|-------------|----------------------------|
| 1. Clutch pedal assembly | 2. Lock nut | 3. Clutch interlock switch |
| 4. ASCD clutch switch | 5. Lock nut | |

REMOVAL

1. Remove instrument lower finisher. Refer to [IP-11, "Removal and Installation"](#).
2. Disconnect clutch interlock switch and ASCD clutch switch harness connectors.
3. Remove clutch switch harness clamp from clutch pedal assembly.
4. Disconnect master cylinder rod end from clutch pedal lever.
5. Remove clutch pedal assembly nuts, and then remove clutch pedal assembly.

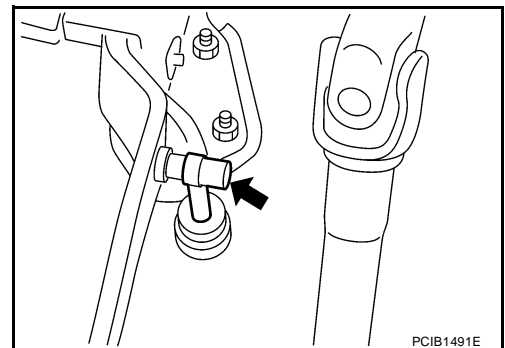

INSPECTION AFTER REMOVAL

Check clutch pedal for bend, damage or a cracked weld. If bend, damage or a cracked weld is found, replace clutch pedal assembly.

INSTALLATION

Installation is in the reverse order of removal.

- After installing the clutch switches, adjust the switch positions. Refer to [CL-5, "On-vehicle Inspection and Adjustment"](#).

A
B
CL
D
E
F
G
H
I
J
K
L
M

CLUTCH FLUID

PF0:00017

CLUTCH FLUID

Air Bleeding Procedure

ECS00FSY

NOTE:

Do not use a vacuum assist or any other type of power bleeder on this system. Use of a vacuum assist or power bleeder will not purge all the air from the system.

CAUTION:

- Carefully monitor fluid level in reservoir tank during bleeding operation.
- Keep painted surface of body and other parts free of clutch fluid. If it spills, wipe up immediately and wash the affected area with water.

- First bleed the air from the operating cylinder air bleed valve (1) and then from the bleed connector air bleed valve.

1. Connect a transparent vinyl tube and container to the air bleeder valve on the clutch operating cylinder.
2. Fill reservoir tank with new clutch fluid.
3. Depress and release the clutch pedal slowly and fully 15 times at an interval of 2 to 3 seconds.
4. With pedal depressed, continue the bleeding procedure.

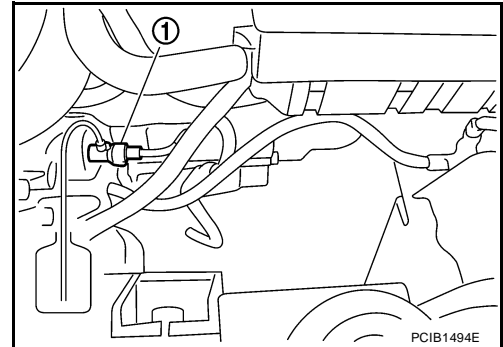

5. Push the lock pin (1) of the bleeding connector (2) into the locked position.

CAUTION:

Hold it to prevent releasing clutch tube from bleeding connector (2) when fluid pressure is applied in the tube.

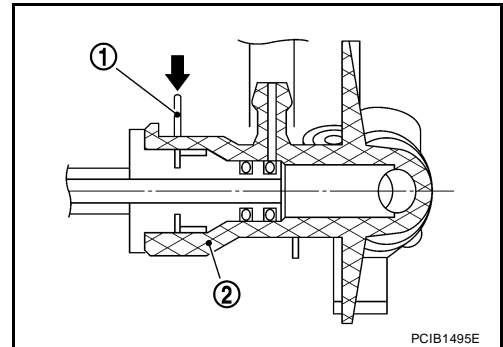

6. Slide clutch tube (1) in the direction of the arrow as shown, then bleed the air from the tube.

Dimension A : 5 mm (0.20 in)

7. Return clutch tube (1) and lock pin (2) to their original positions.
8. Release clutch pedal and wait for 5 seconds.
9. Repeat steps 2 to 8 until no bubbles are observed in the clutch fluid.

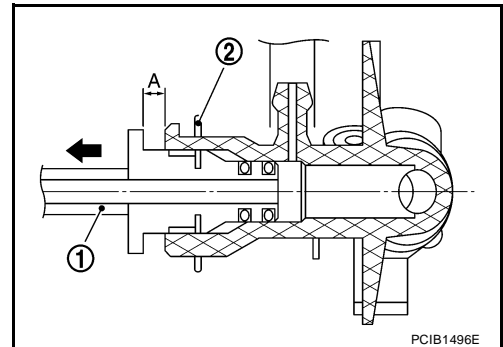

CLUTCH MASTER CYLINDER

CLUTCH MASTER CYLINDER

PFP:30610

Removal and Installation

ECS00FSZ

REMOVAL

1. Use one of the following methods to remove hose from master cylinder.
 - Drain clutch fluid from reservoir tank and remove hose.
 - Remove hose from master cylinder. Immediately plug hose and reservoir tank to prevent clutch fluid from dripping.

CAUTION:

Keep painted surface of the body and other parts free of clutch fluid. If it spills, wipe up immediately and wash the affected area with water.

2. Remove master cylinder rod end from clutch pedal assembly.

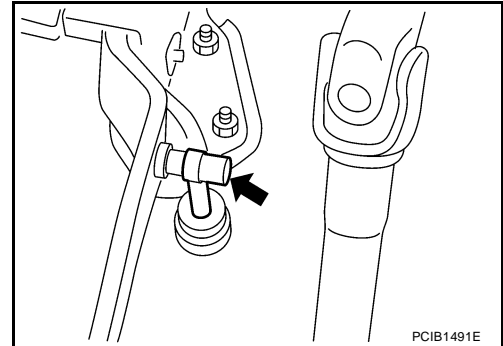

3. Remove lock pin (1) from connector of master cylinder (2) and separate clutch tube (3).

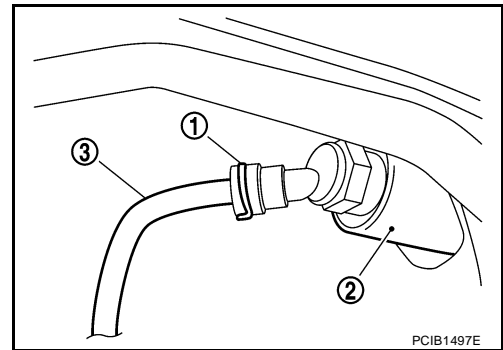

4. Rotate master cylinder clockwise by 45° and remove from the vehicle.

INSTALLATION

1. Tilt master cylinder clockwise by 45° and insert it in the mounting hole. Rotate counterclockwise to secure it. At this time, nipple is in the up position.
2. Install master cylinder rod end to clutch pedal.

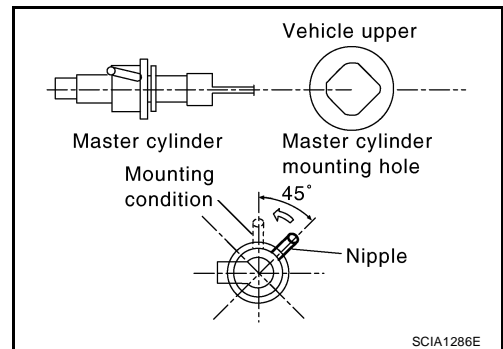

CLUTCH MASTER CYLINDER

3. Install clutch tube (1) fully into connector of master cylinder (2).
4. Install lock pin (3) fully into connector of master cylinder (2).
5. Fill with new clutch fluid and bleed air from the system. Refer to [CL-8, "CLUTCH FLUID"](#).
6. After completing this procedure, inspect and adjust the clutch pedal. Refer to [CL-5, "On-vehicle Inspection and Adjustment"](#).

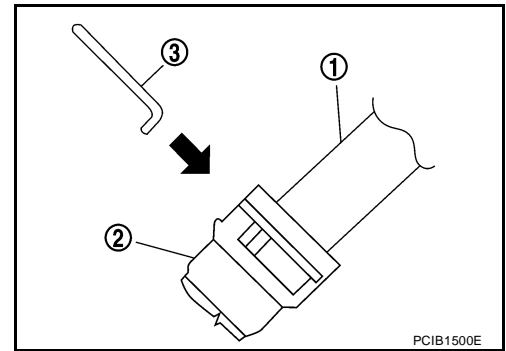

CSC (CONCENTRIC SLAVE CYLINDER)

CSC (CONCENTRIC SLAVE CYLINDER)

PFP:30500

Removal and Installation

ECS00FT0

CAUTION:

- If transaxle assembly is removed from the vehicle, always replace CSC (Concentric slave cylinder). Return CSC insert to original position to remove transaxle assembly. Dust on clutch disc sliding parts may damage CSC seal and may cause clutch fluid leakage.
- Keep painted surface of the body and other parts free of clutch fluid. If it spills, wipe up immediately and wash the affected area with water.

REMOVAL

1. Remove transaxle assembly. Refer to [MT-15, "Removal and Installation"](#).
2. Remove CSC bolts and the CSC from clutch housing.

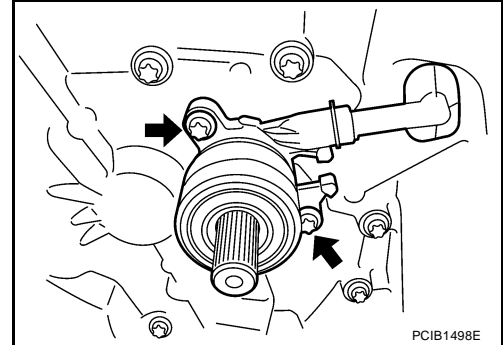

INSTALLATION

1. Install CSC to clutch housing and then tighten bolts to specification. Refer to [MT-17, "Case and Housing Components"](#).

CAUTION:

- Do not reuse CSC.
 - Do not insert and operate CSC because piston and stopper of CSC components may fall off.
2. Install transaxle assembly. Refer to [MT-15, "Removal and Installation"](#).
 3. Bleed the air from the clutch hydraulic system. Refer to [CL-8, "Air Bleeding Procedure"](#).

CLUTCH PIPING

PF3:30650

CLUTCH PIPING

Removal and Installation

ECS00FT1

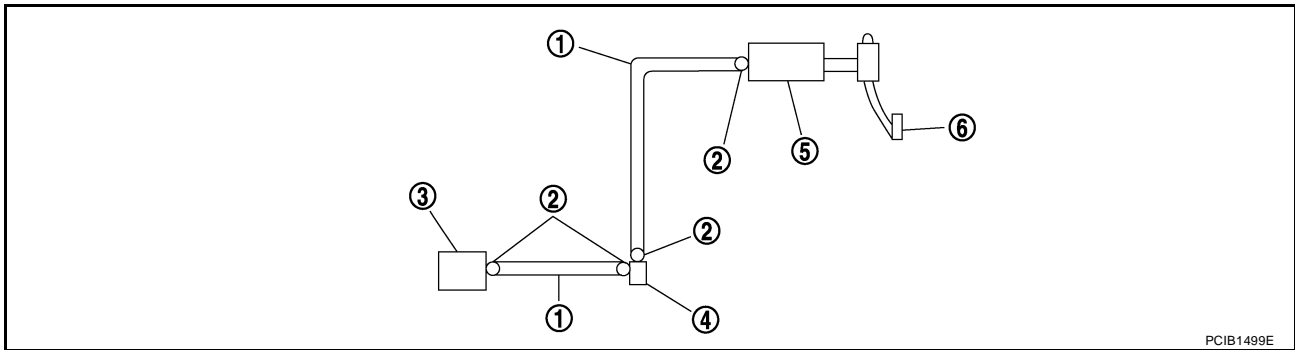

- | | | |
|------------------|--------------------|-----------------|
| 1. Clutch tube | 2. Lock pin | 3. CSC |
| 4. Clutch damper | 5. Master cylinder | 6. Clutch pedal |

Carefully observe the following steps during clutch tube removal and installation.

CAUTION:

Keep painted surface of the body and other parts free of clutch fluid. If it spills, wipe up immediately and wash the affected area with water.

REMOVAL

1. Remove lock pin (2) from clutch damper (3).
2. Remove clutch tube (1) from clutch damper (3).
3. Remove clutch damper (3) from bracket (4).

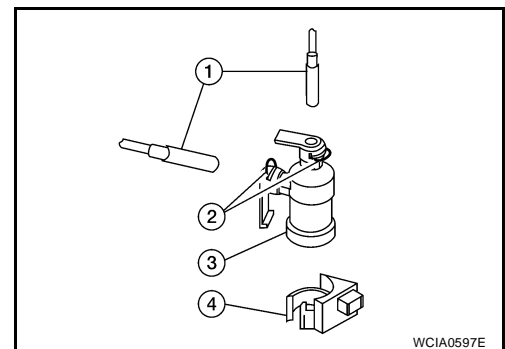

INSTALLATION

Installation is in the reverse order of removal.

- Make sure that all tubes are fully installed into connectors.
- Make sure that all connector lock pins are fully installed.
- After installation, bleed the air from the clutch hydraulic system. Refer to [CL-8, "Air Bleeding Procedure"](#).

CLUTCH DISC, CLUTCH COVER AND FLYWHEEL

- Use a suitable tool to measure the depth to clutch disc facing rivet heads. If it exceeds the allowable wear limit, replace clutch disc.

Wear limit of facing surface to rivet head : 0.3 mm (0.012 in)

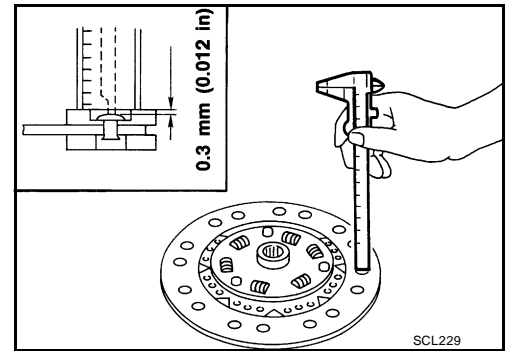

Clutch Cover

Check clutch cover installed on vehicle for unevenness of diaphragm spring toe height.

Uneven limit : 0.7 mm (0.028 in) or less

Tool number A : ST20050240 (—)

- If out of limit, adjust the height using Tool (A).
- Check clutch cover thrust ring for wear or breakage. If wear or breakage is found, replace clutch cover assembly.

NOTE:

- Worn thrust ring will generate a beating noise when tapped at the rivet with a suitable tool.
- Broken thrust ring will make a clinking sound when cover is shaken up and down.
- If a trace of burn or discoloration is found on the clutch cover pressure plate to clutch disc contact surface, repair the surface with sandpaper. If surface is damaged or distorted, replace the assembly.

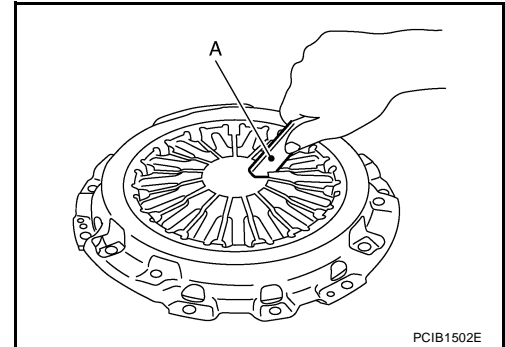

Flywheel Runout

- Check contact surface of flywheel for slight burns or discoloration. Repair flywheel with emery paper.
- Check the flywheel runout. Refer to [EM-103, "FLYWHEEL DEFLECTION \(M/T MODELS\)"](#).

CAUTION:

Measure flywheel outer face (not on knock pin and clutch cover mounting hole).

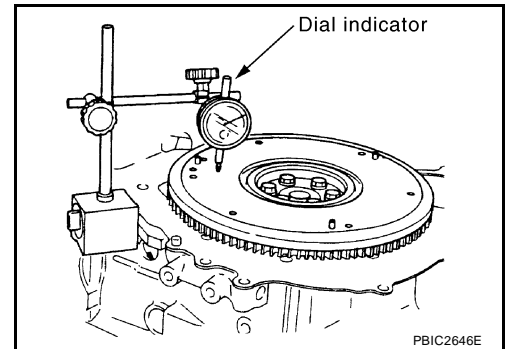

INSTALLATION

1. Clean clutch disc and input shaft splines to remove grease and dust caused by abrasion.
2. Apply recommended grease to clutch disc and input shaft splines.

CAUTION:

Be sure to apply grease to the points specified. Otherwise, noise, poor disengagement, or damage to the clutch may result. Excessive grease may cause slip or shudder. If it adheres to CSC seal, it will cause clutch fluid leakage. Wipe off excess grease.

3. Install clutch disc using tool.

Tool number : KV30101000 (—)

4. Install clutch cover. Pre-tighten clutch cover bolts.

CLUTCH DISC, CLUTCH COVER AND FLYWHEEL

5. Tighten clutch cover bolts evenly in two steps in the order shown. Refer to [CL-13, "COMPONENTS"](#).
6. Install transaxle assembly. Refer to [MT-15, "Removal and Installation"](#).

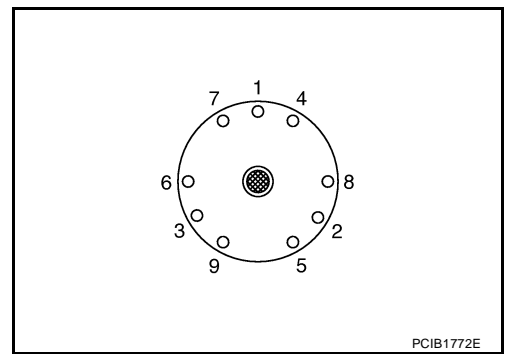

A

B

CL

D

E

F

G

H

I

J

K

L

M

SERVICE DATA AND SPECIFICATIONS (SDS)

SERVICE DATA AND SPECIFICATIONS (SDS)

PFP:00030

Clutch Control System

ECS00FT3

Type of clutch control	Hydraulic
------------------------	-----------

Clutch Pedal

ECS00FT4

Clearance "A" between clutch pedal and ASCD switch threaded end while clutch pedal is fully released.	0.74 - 1.96 mm (0.0291 - 0.0772 in)
Clearance "C" between clutch pedal and clutch interlock switch threaded end while clutch pedal is fully depressed.	0.74 - 1.96 mm (0.0291 - 0.0772 in)

Clutch Disc

ECS00FT5

Model	225
Facing size (outer dia. × inner dia. × thickness)	225 mm × 160 mm × 3.2 mm (8.86 in × 6.30 in × 0.126 in)
Thickness of disc assembly with load	7.2 - 7.6 mm (0.283 - 0.299 in) with 5,394 N (550 kg, 1,213 lb)
Runout limit/diameter of the area to be measured	1.0 mm (0.039 in) / 215 mm (8.46 in) dia.
Maximum spline backlash (at outer edge of disc)	1.0 mm (0.039 in)
Wear limit of facing surface to rivet head	0.3 mm (0.012 in)

Clutch Cover

ECS00FT6

Set-load	5,394 N (550 kg, 1,213 lb)
Diaphragm spring lever height	20 - 22 mm (0.79 - 0.87 in)
Uneven limit diaphragm spring toe height	0.7 mm (0.028 in) or less