

SECTION **AV**

AUDIO, VISUAL, NAVIGATION & TELEPHONE SYSTEM

CONTENTS

PRECAUTIONS	3	Satellite Radio Tuner (Factory Installed) Power and Ground Supply Circuit Inspection	25
Precautions for Supplemental Restraint System (SRS) "AIR BAG" and "SEAT BELT PRE-TENSIONER"	3	Satellite Radio Tuner (Factory Installed) Communication Circuit Inspection	26
PREPARATION	4	Satellite Radio Tuner (Factory Installed) Left Channel Audio Signal Circuit Inspection	28
Commercial Service Tool	4	Satellite Radio Tuner (Factory Installed) Right Channel Audio Signal Circuit Inspection	29
AUDIO	5	Steering Switch Check (With Bluetooth)	30
Component Parts Location	5	Sound Is Not Heard From Front Door Speaker (Base System)	32
System Description	5	Sound Is Not Heard From Rear Door Speaker (Base System)	34
BASE SYSTEM	5	Sound Is Not Heard From Front Door Speaker or Tweeter (Mid Level and Premium System)	36
MID LEVEL AND PREMIUM SYSTEM	5	Sound Is Not Heard From Rear Door Speaker (Mid Level and Premium System)	38
SPEED SENSITIVE VOLUME SYSTEM (MID LEVEL AND PREMIUM SYSTEM)	6	Sound Is Not Heard From Subwoofer (Premium System)	40
Schematic	7	Removal and Installation	43
MID LEVEL SYSTEM	7	AUDIO UNIT	43
PREMIUM SYSTEM	8	FRONT DOOR SPEAKER	43
Wiring Diagram — AUDIO —	9	REAR DOOR SPEAKER	43
BASE SYSTEM	9	TWEETER	43
MID LEVEL SYSTEM	10	SATELLITE TUNER MODULE	44
PREMIUM SYSTEM	12	SATELLITE TUNER ANTENNA	45
Audio Unit (Base System) Harness Connector Terminal Layout	16	STEERING WHEEL AUDIO CONTROL SWITCHES	46
Terminals and Reference Value for Audio Unit (Base System)	16	SUBWOOFER	47
Audio Unit (Mid Level and Premium System) Harness Connector Terminal Layout	17	AUDIO ANTENNA	48
Terminals and Reference Value for Audio Unit (Mid Level and Premium System)	17	Location of Antenna	48
Subwoofer Harness Connector Terminal Layout (Premium Audio System)	20	Removal and Installation of Roof Antenna	48
Terminals and Reference Value for Subwoofer (Premium Audio System)	20	REMOVAL	48
Satellite Radio Tuner Harness Connector Terminal Layout	21	INSTALLATION	48
Terminals and Reference Value for Satellite Radio Tuner	21	TELEPHONE	49
Trouble Diagnosis	23	Component Parts and Harness Connector Location	49
Noise Inspection	23	System Description	49
TYPE OF NOISE AND POSSIBLE CAUSE	24	BLUETOOTH® HANDS-FREE PHONE SYSTEM	49
Power Supply Circuit Inspection	24	Wiring Diagram — H/PHON —	52

A
B
C
D
E
F
G
H
I
J
AV
L
M

Bluetooth Control Unit Harness Connector Terminal Layout	54	Operate	59
Terminals and Reference Value for Bluetooth Control Unit	54	Voice Activated Control Function Does Not Operate..	60
Bluetooth Control Unit Self-Diagnosis Function	56	BLUETOOTH VOICE GUIDANCE IS HEARD	
BLUETOOTH CONTROL UNIT INITIALIZATION		WHEN PRESSING STEERING WHEEL AUDIO	
CHECKS	56	CONTROL SWITCH	60
SELF-DIAGNOSIS MODE	56	BLUETOOTH VOICE GUIDANCE IS NOT	
Workflow	57	HEARD WHEN PRESSING STEERING WHEEL	
Power Supply and Ground Circuit Check for Bluetooth Control Unit	57	AUDIO CONTROL SWITCH	61
Basic Inspection of Hands-Free Phone	58	Removal and Installation	63
Steering Wheel Audio Control Switch Does Not		BLUETOOTH CONTROL UNIT	63
		BLUETOOTH ANTENNA	64
		BLUETOOTH MICROPHONE	65

PRECAUTIONS

PRECAUTIONS

PF0:00001

Precautions for Supplemental Restraint System (SRS) “AIR BAG” and “SEAT BELT PRE-TENSIONER”

EKS00ICV

The Supplemental Restraint System such as “AIR BAG” and “SEAT BELT PRE-TENSIONER”, used along with a front seat belt, helps to reduce the risk or severity of injury to the driver and front passenger for certain types of collision. This system includes seat belt switch inputs and dual stage front air bag modules. The SRS system uses the seat belt switches to determine the front air bag deployment, and may only deploy one front air bag, depending on the severity of a collision and whether the front occupants are belted or unbelted. Information necessary to service the system safely is included in the SRS and SB section of this Service Manual.

WARNING:

- To avoid rendering the SRS inoperative, which could increase the risk of personal injury or death in the event of a collision which would result in air bag inflation, all maintenance must be performed by an authorized NISSAN/INFINITI dealer.
- Improper maintenance, including incorrect removal and installation of the SRS, can lead to personal injury caused by unintentional activation of the system. For removal of Spiral Cable and Air Bag Module, see the SRS section.
- Do not use electrical test equipment on any circuit related to the SRS unless instructed to in this Service Manual. SRS wiring harnesses can be identified by yellow and/or orange harnesses or harness connectors.

A
B
C
D
E
F
G
H
I
J
L
M

AV

PREPARATION

PREPARATION

PF0:00002

Commercial Service Tool

EKS0019D

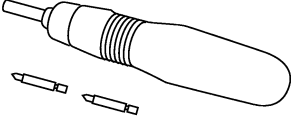
Tool name	Description
<p data-bbox="162 300 272 323">Power tool</p>  <p data-bbox="852 499 922 514">PBIC0191E</p>	<p data-bbox="1015 300 1266 323">Loosening bolts and nuts</p>

AUDIO

Component Parts Location

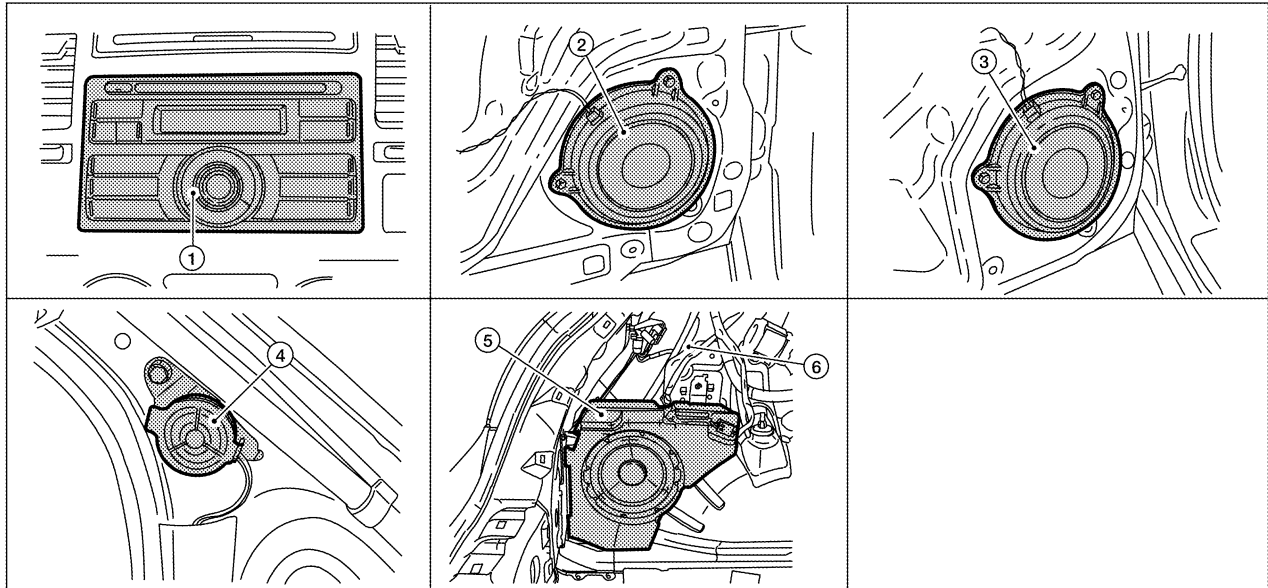

- | | | |
|--|--|--|
| 1. Audio unit M43, M44 and M45 | 2. Front door speaker LH D12, RH D112 | 3. Rear door speaker LH D207, RH D307 |
| 4. Tweeter LH M46, RH M47 (view with front pillar garnish removed) | 5. Subwoofer B29 (premium system) [view with luggage side lower finisher (LH) removed] | 6. Satellite radio tuner B30 and B31 (if equipped) |

WKIA542ZE

System Description

BASE SYSTEM

EKS001A5

Refer to Owner's Manual for audio system operating instructions.

Power is supplied at all times

- through 20A fuse (No. 27, located in the fuse and fusible link box)
- to audio unit terminal 19.

With the ignition switch in the ACC or ON position, power is supplied

- through 10A fuse (No. 20, located in the fuse and fusible link box)
- to audio unit terminal 7.

Ground is supplied through the case of the audio unit.

Then audio signals are supplied

- through audio unit terminals 2, 3, 4, 5, 11, 12, 13 and 14
- to terminals + and - of front door speaker LH and RH and
- to terminals + and - of rear door speaker LH and RH.

MID LEVEL AND PREMIUM SYSTEM

Refer to Owner's Manual for audio system operating instructions.

Power is supplied at all times

- through 20A fuse (No. 27, located in the fuse and fusible link box)
- to audio unit terminal 19 and
- to subwoofer terminal 1 (with premium system).

With the ignition switch in the ACC or ON position, power is supplied

- through 10A fuse (No. 20, located in the fuse and fusible link box)
- to audio unit terminal 7.

Ground is supplied through the case of the audio unit.

Ground is also supplied

- to audio unit terminal 21 (with premium system)

A

B

C

D

E

F

G

H

I

J

AV

L

M

AUDIO

- through body grounds M57 and M61 and
- to subwoofer terminal 3 (with premium system)
- through body grounds B7 and B19.

Then audio signals are supplied

- through audio unit terminals 2, 3, 4, 5, 11, 12, 13, and 14
- to terminals + and - of front door speaker LH and RH and
- to terminals + and - of tweeter LH and RH and
- to terminals + and - of rear door speaker LH and RH and
- to terminals 2 and 6 of subwoofer (with premium system).

Steering Wheel Audio Control Switches (with Bluetooth)

When one of steering wheel audio control switches is pushed, the resistance in steering switch circuit changes depending on which button is pushed.

Satellite Radio Tuner (Pre-wiring)

The satellite radio tuner pre-wiring allows connection of a satellite radio tuner.

Power is supplied at all times

- through 20A fuse (No. 27, located in the fuse and fusible link box)
- to satellite radio tuner pre-wiring terminal 32.

With the ignition switch in the ACC or ON position, power is supplied

- through 10A fuse (No. 20, located in the fuse and fusible link box)
- to satellite radio tuner pre-wiring terminal 36.

Then audio signals are supplied

- through satellite radio tuner pre-wiring terminals 21, 22, 23 and 24
- to audio unit terminals 41, 42, 43 and 44.

Satellite Radio Tuner (Factory Installed)

Power is supplied at all times

- through 20A fuse (No. 27, located in the fuse and fusible link box)
- to satellite radio tuner terminal 32.

With the ignition switch in the ACC or ON position, power is supplied

- through 10A fuse (No. 20, located in the fuse and fusible link box)
- to satellite radio tuner terminal 36.

Ground is supplied through the case of the satellite radio tuner.

Then audio signals are supplied

- through satellite radio tuner terminals 21, 22, 23 and 24
- to audio unit terminals 41, 42, 43 and 44.

Ground is supplied through the case of the satellite radio tuner.

SPEED SENSITIVE VOLUME SYSTEM (MID LEVEL AND PREMIUM SYSTEM)

Volume level of this system goes up and down automatically in proportion to the vehicle speed. The control level can be selected by the customer. Refer to Owner's Manual for operating instructions.

AUDIO

EKS0014C

Schematic MID LEVEL SYSTEM

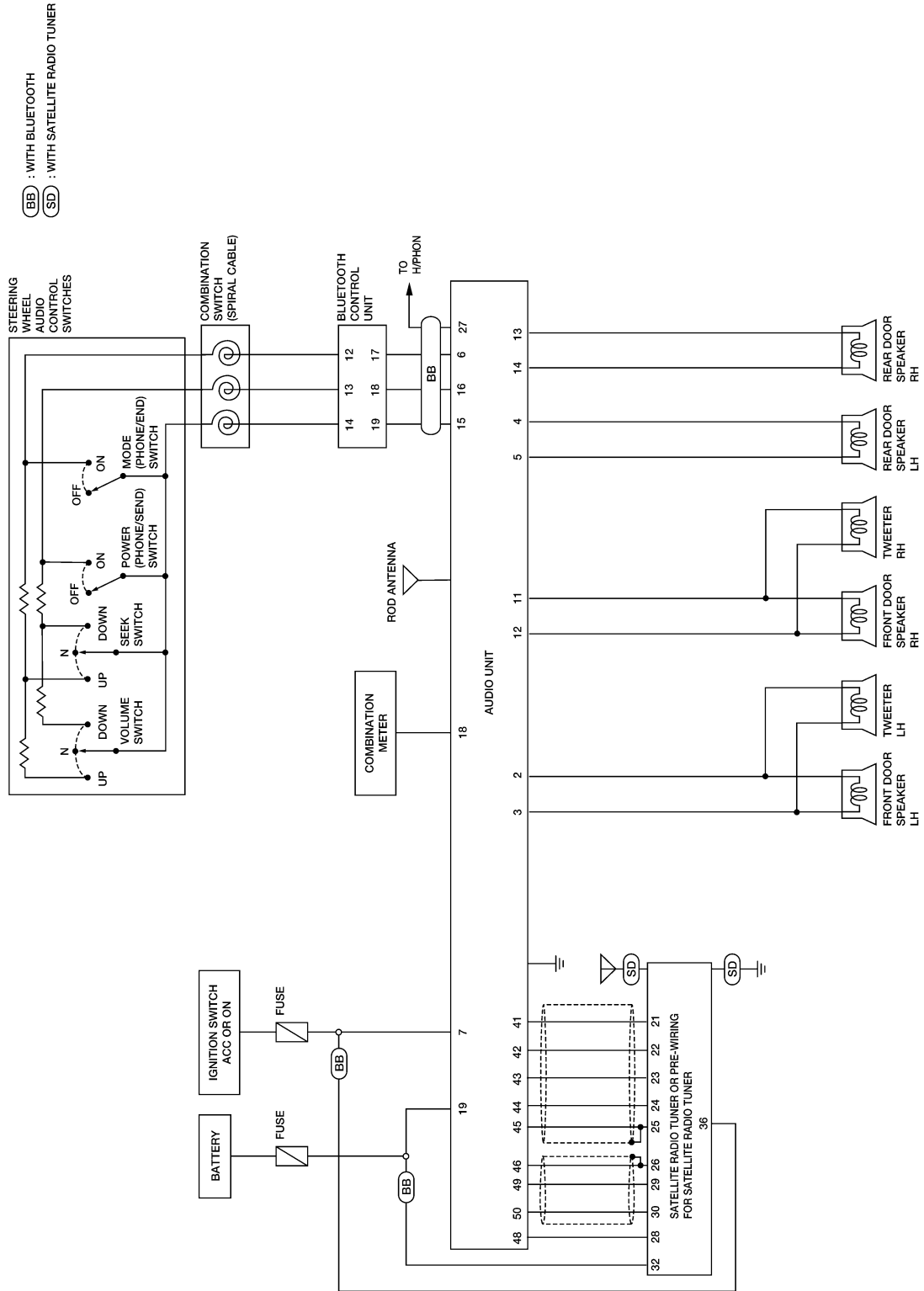

A
B
C
D
E
F
G
H
I
J
L
M

AV

AUDIO

PREMIUM SYSTEM

(SD) : WITH SATELLITE RADIO TUNER

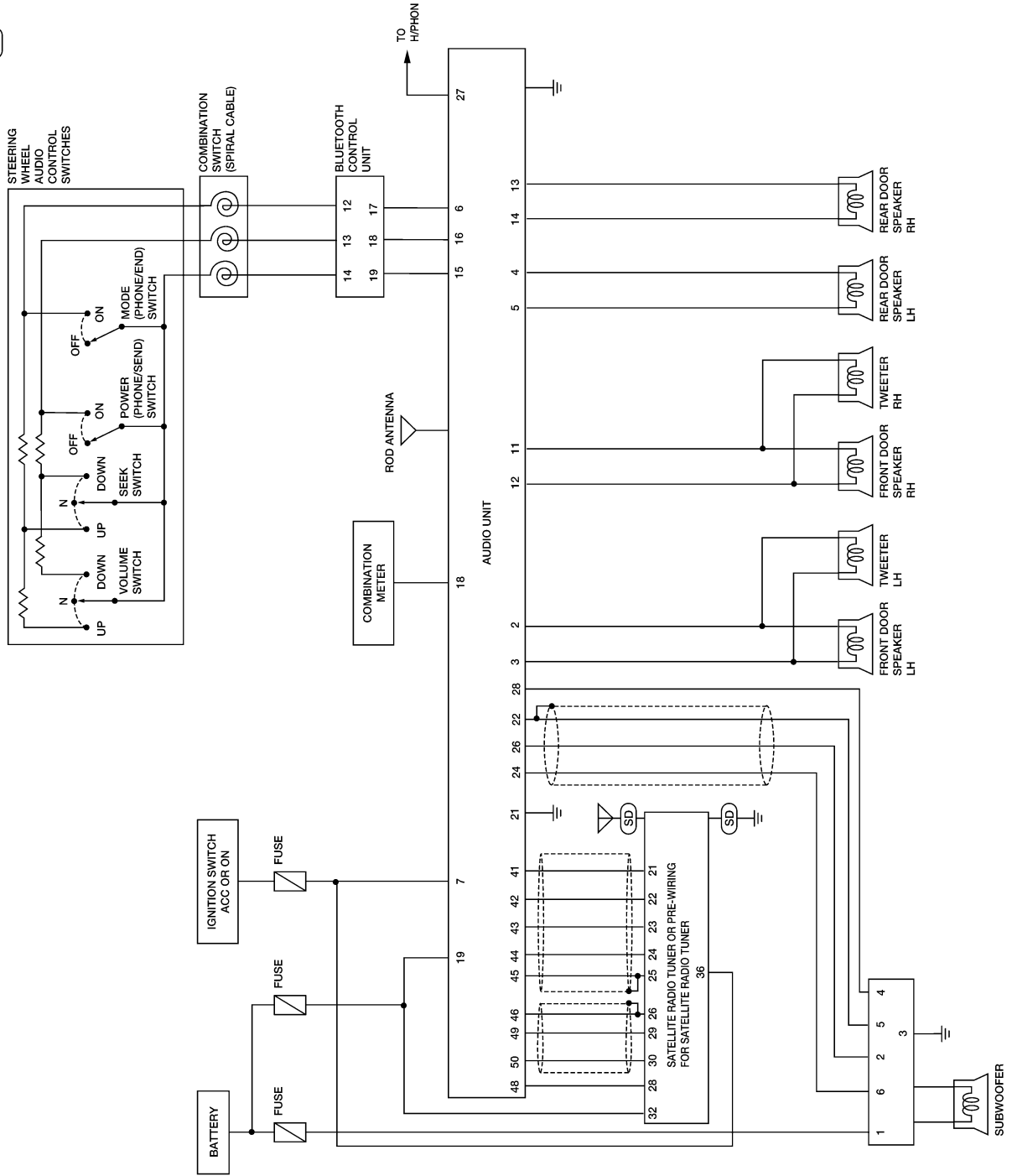

WKWA4983E

AUDIO

Wiring Diagram — AUDIO — BASE SYSTEM

EKS0014D

AV-AUDIO-01

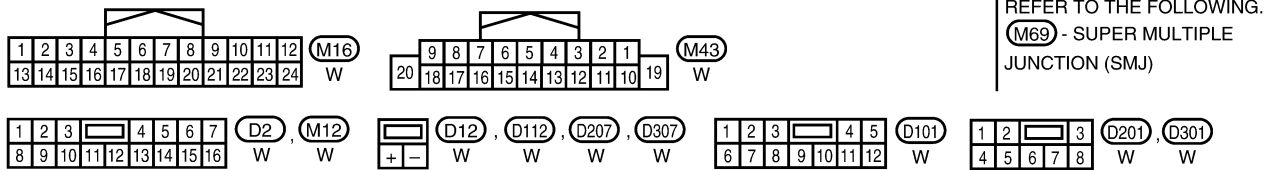
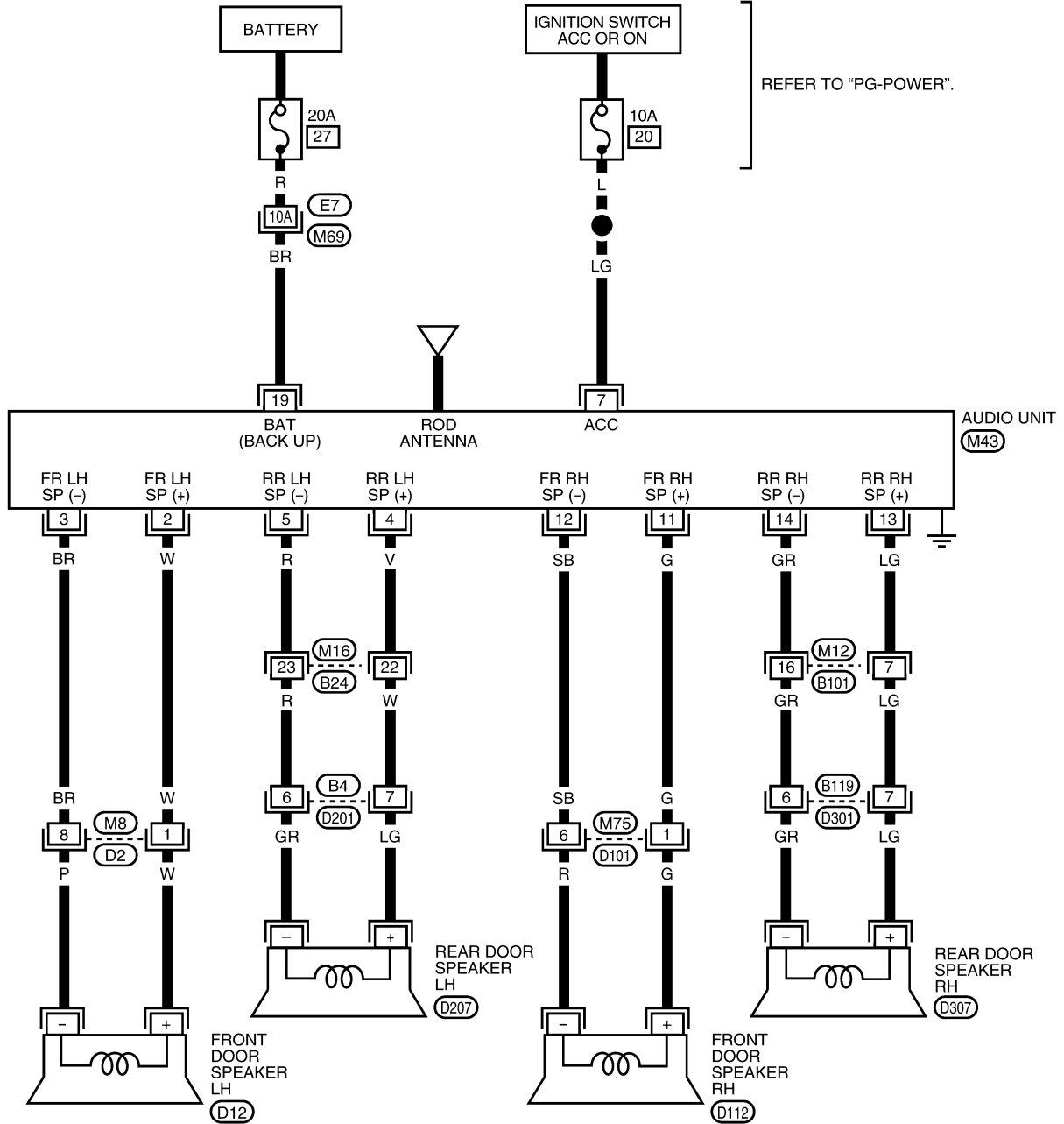

AUDIO

MID LEVEL SYSTEM

AV-AUDIO-02

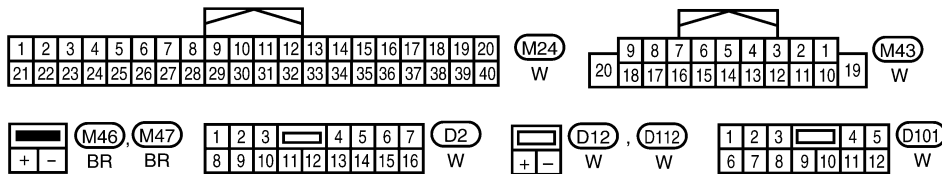
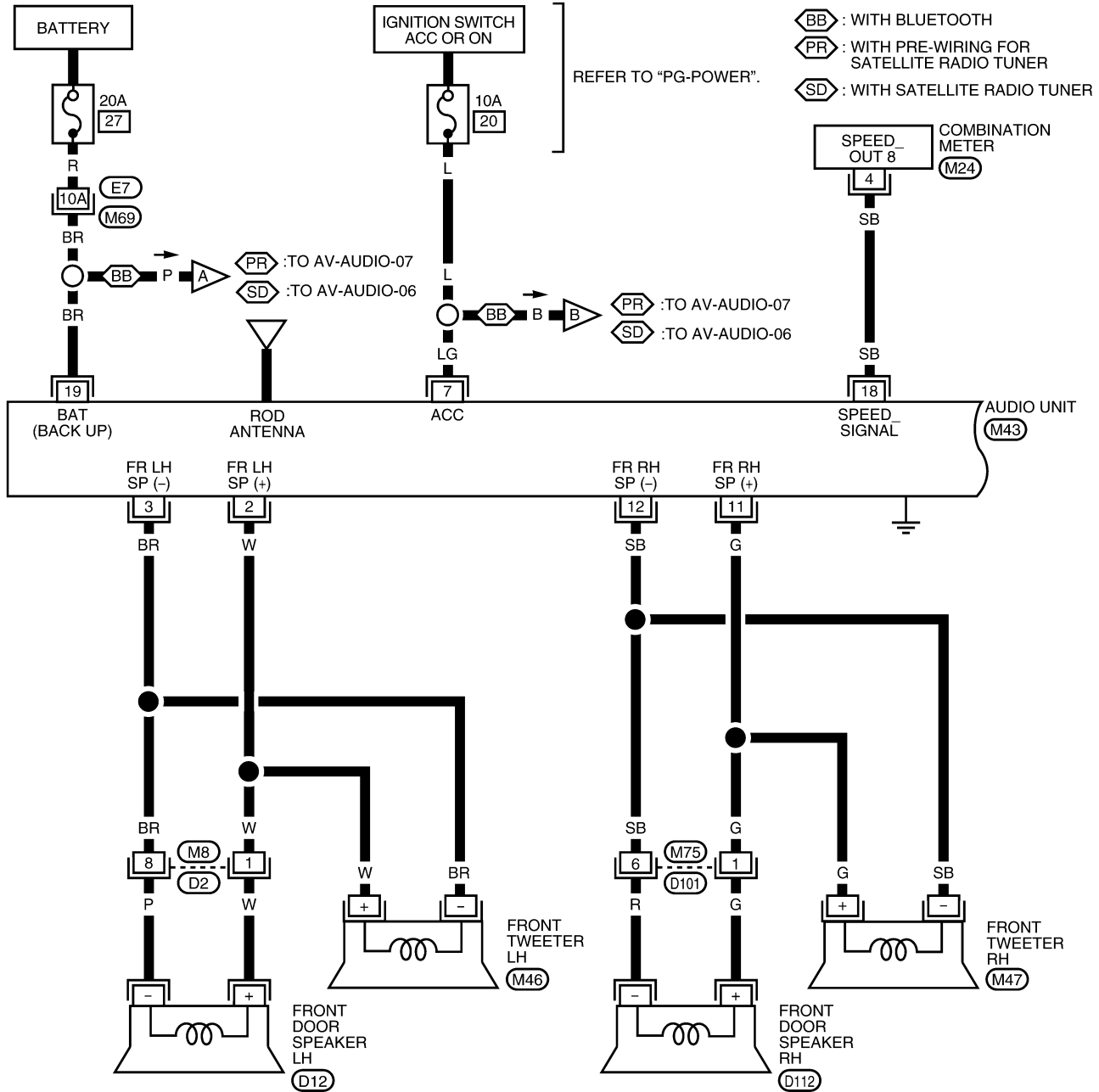

REFER TO THE FOLLOWING.
 (M69) - SUPER MULTIPLE JUNCTION (SMJ)

AUDIO

AV-AUDIO-03

BB : WITH BLUETOOTH

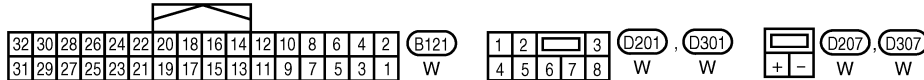
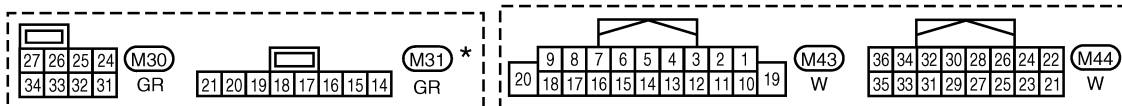
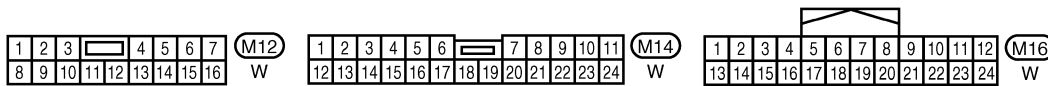
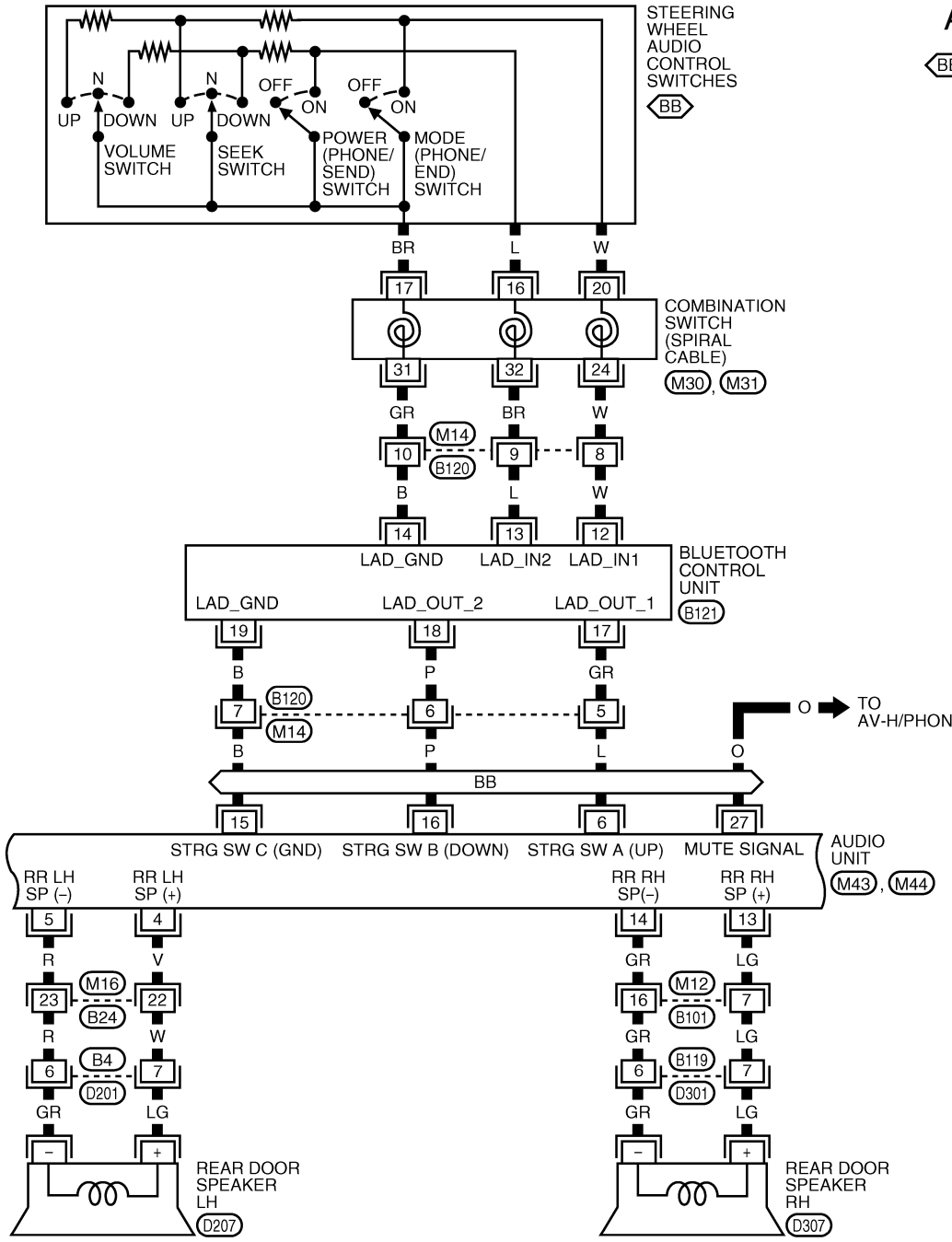

*: THIS CONNECTOR IS NOT SHOWN IN "HARNESS LAYOUT" OF PG SECTION.

WKWA4981E

AUDIO

PREMIUM SYSTEM

AV-AUDIO-04

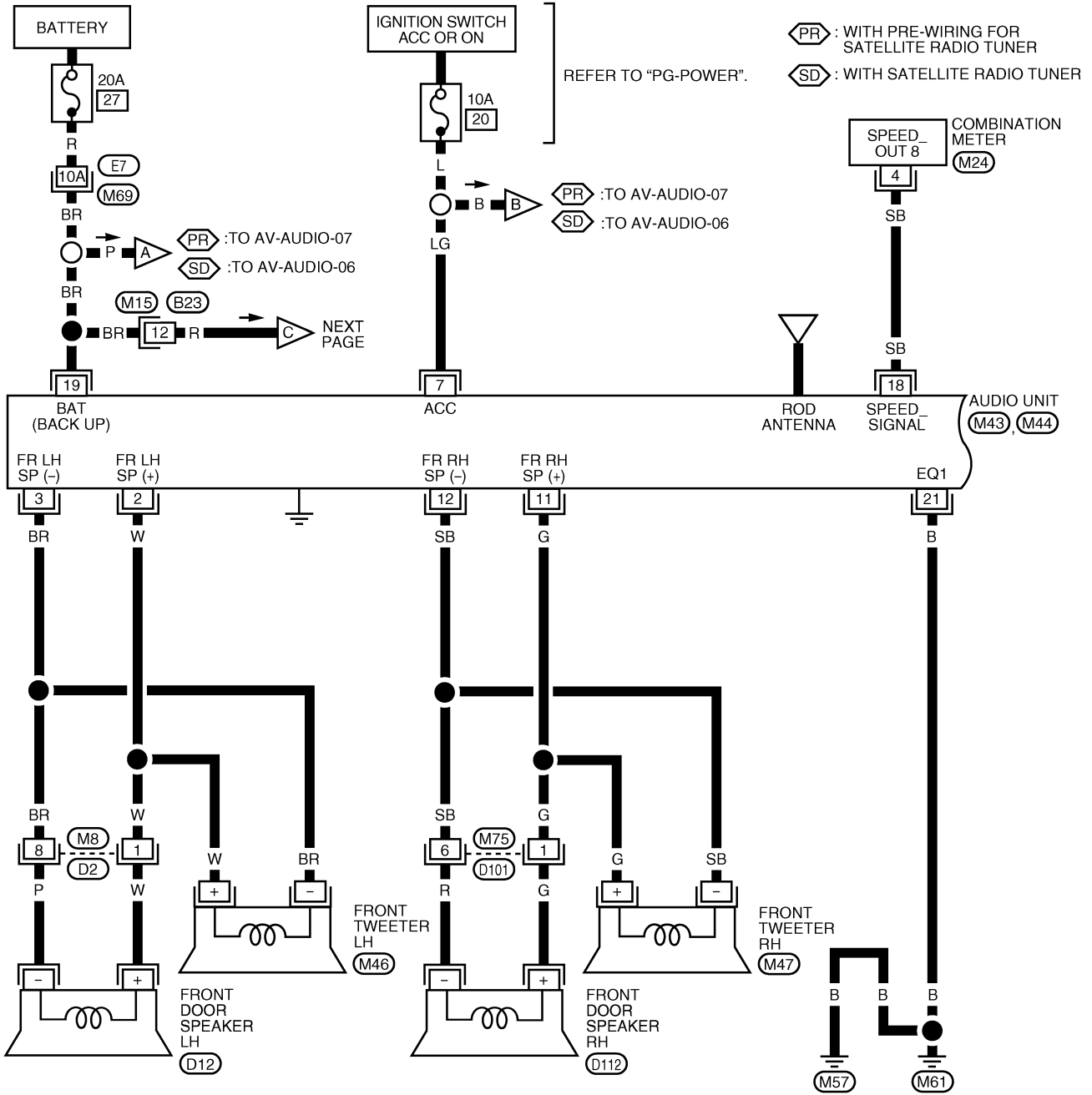

PR : WITH PRE-WIRING FOR SATELLITE RADIO TUNER
 SD : WITH SATELLITE RADIO TUNER

REFER TO "PG-POWER".

AUDIO UNIT (M43, M44)

REFER TO THE FOLLOWING.
 M69 - SUPER MULTIPLE JUNCTION (SMJ)

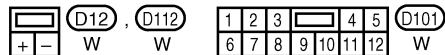
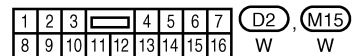
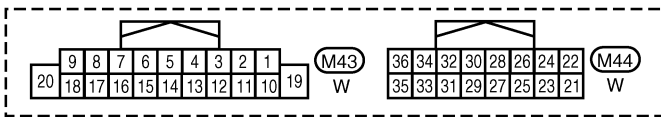
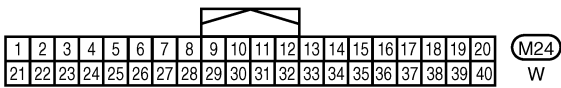

AUDIO

AV-AUDIO-05

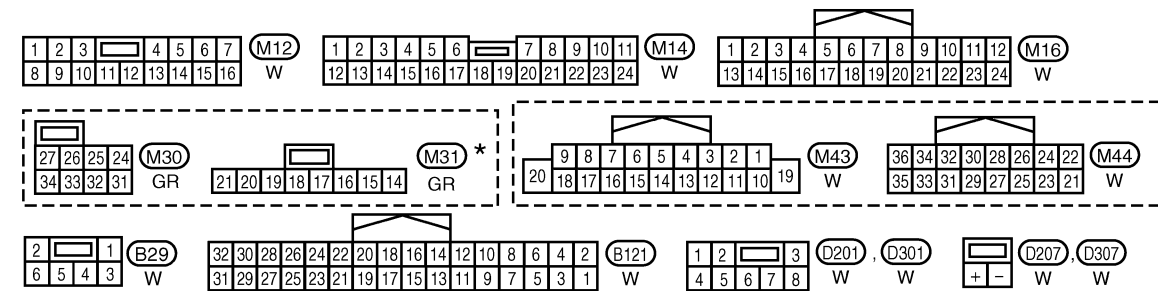
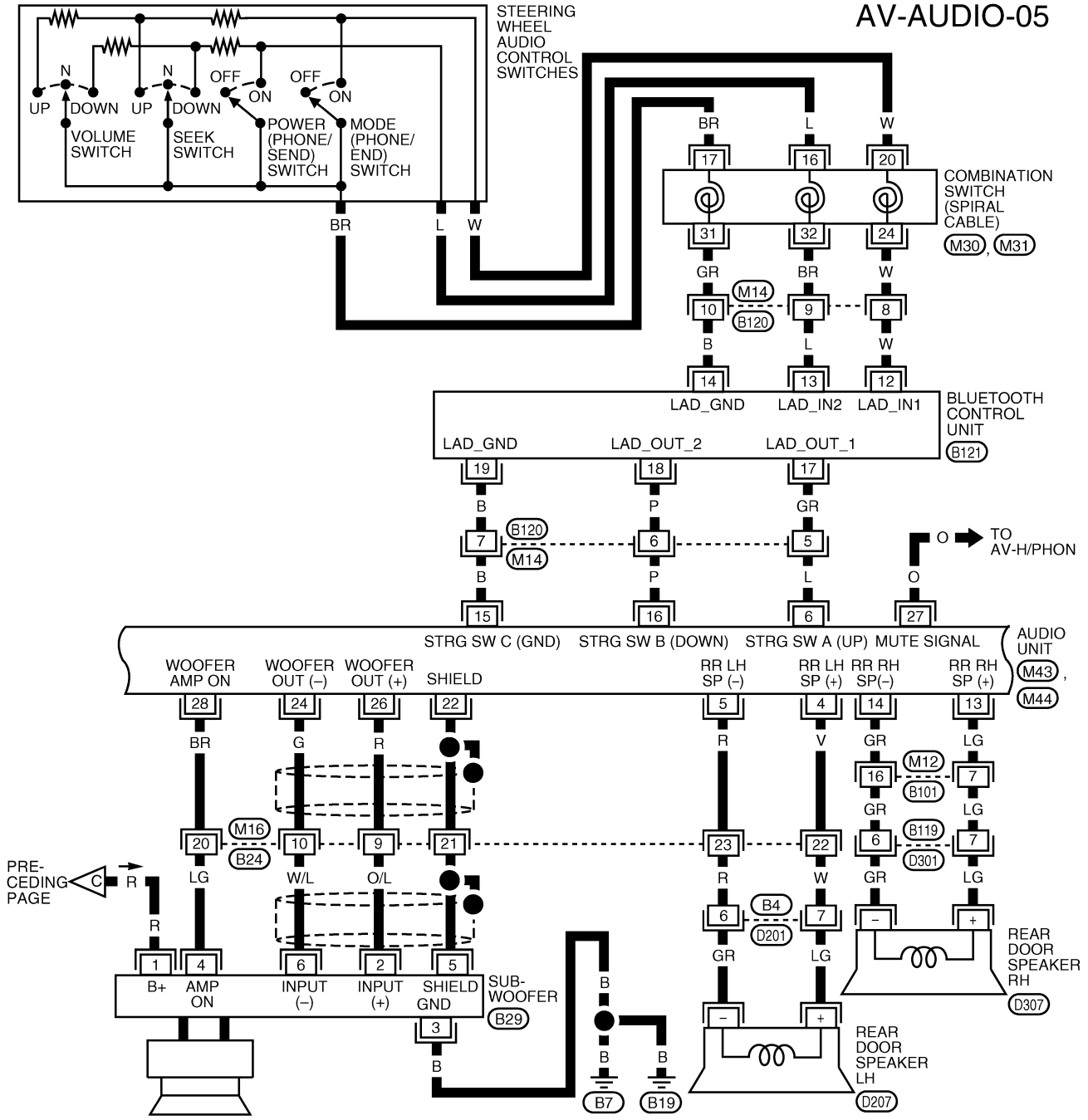

*: THIS CONNECTOR IS NOT SHOWN IN "HARNESS LAYOUT" OF PG SECTION.

WKWA4984E

AUDIO

AV-AUDIO-06

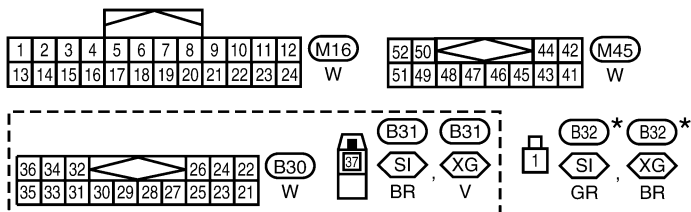
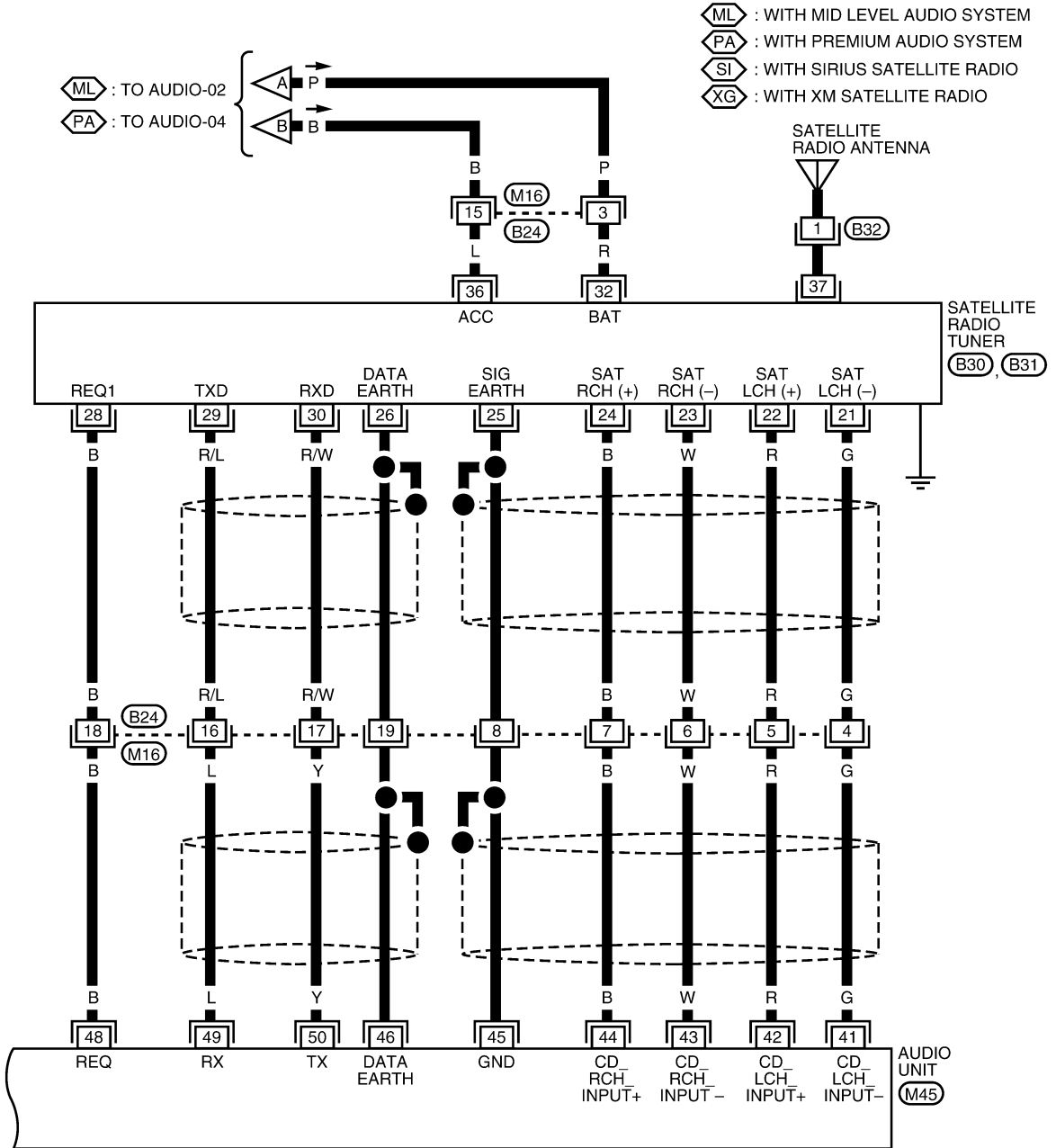

* : THIS CONNECTOR IS NOT SHOWN IN "HARNESS LAYOUT" OF PG SECTION.

WKWA4985E

AUDIO

AV-AUDIO-07

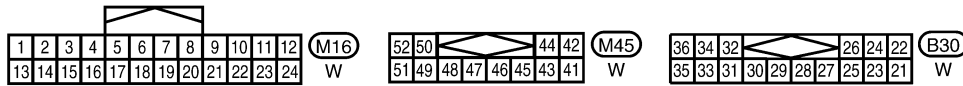
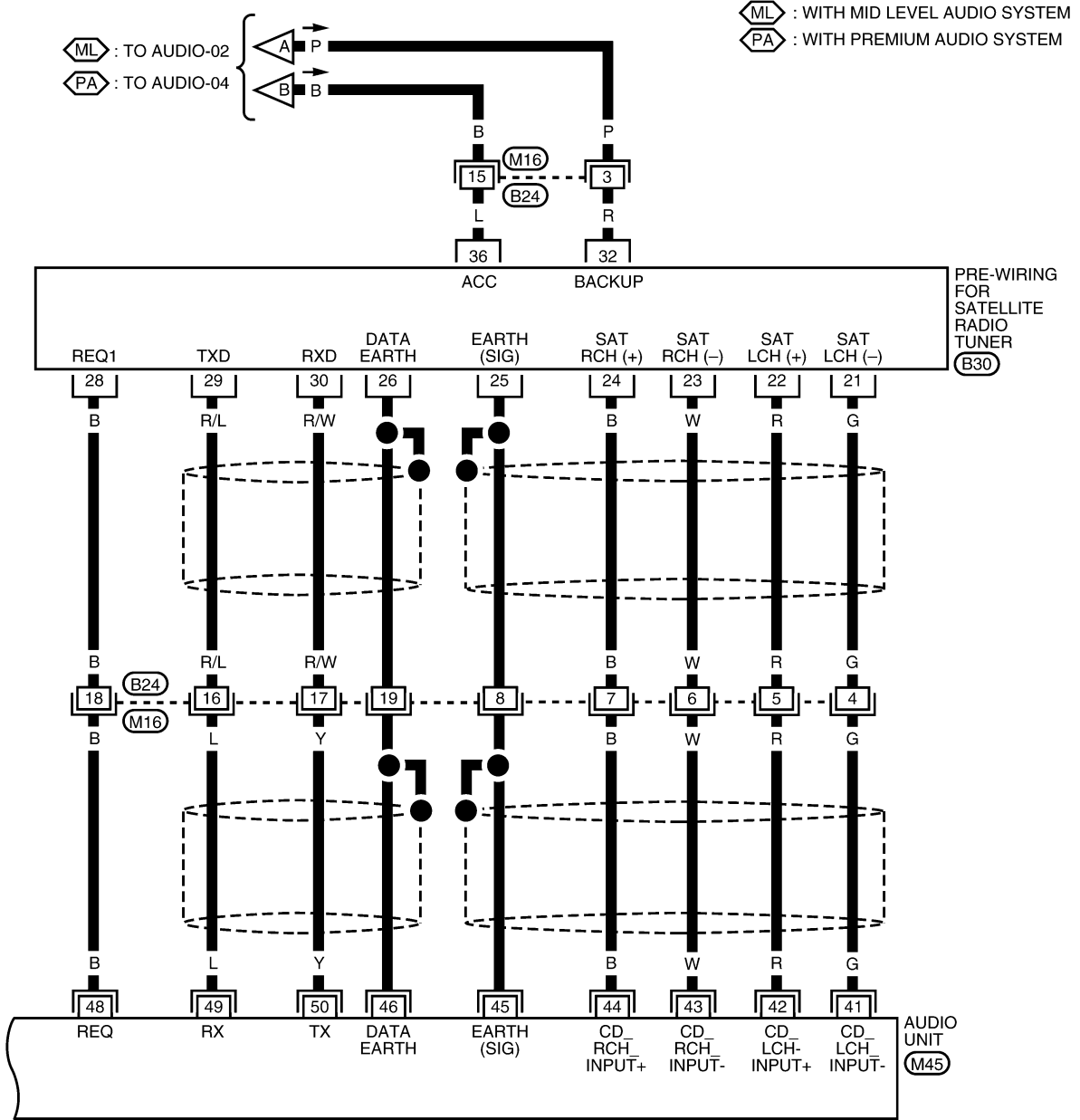

WKWA4986E

AUDIO

Audio Unit (Base System) Harness Connector Terminal Layout

EKS001A0

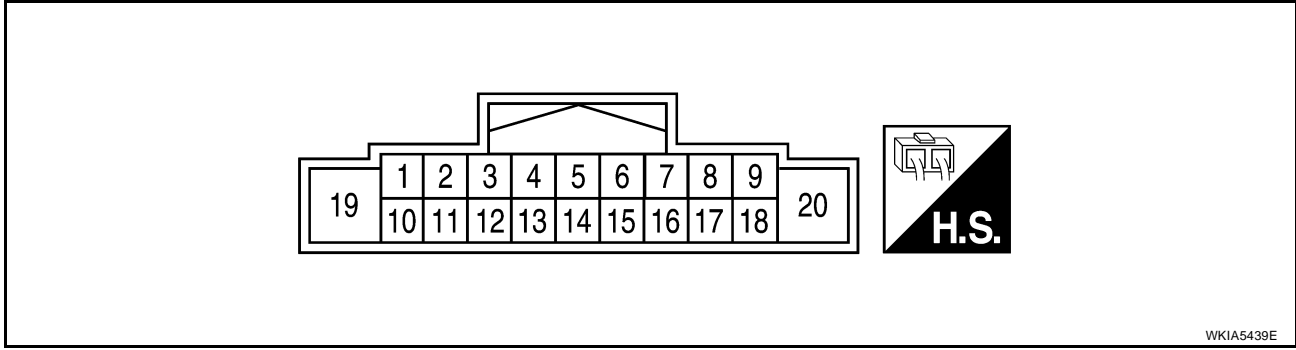

Terminals and Reference Value for Audio Unit (Base System)

EKS0014E

Terminal (Wire color)		Item	Signal input/ output	Condition		Reference value (Approx.)
+	-			Ignition switch	Operation	
2 (W)	3 (BR)	Audio signal front LH	Output	ON	Receive audio signal	<p style="text-align: right;">SKIB3609E</p>
4 (V)	5 (R)	Audio signal rear LH	Output	ON	Receive audio signal	<p style="text-align: right;">SKIB3609E</p>
7 (LG)	Ground	ACC power supply	Input	ACC	-	Battery voltage
11 (G)	12 (SB)	Audio signal front RH	Output	ON	Receive audio signal	<p style="text-align: right;">SKIB3609E</p>
13 (LG)	14 (GR)	Audio signal rear RH	Output	ON	Receive audio signal	<p style="text-align: right;">SKIB3609E</p>
19 (BR)	Ground	Battery power supply	Input	OFF	-	Battery voltage

AUDIO

Audio Unit (Mid Level and Premium System) Harness Connector Terminal Lay-out

EKS0019N

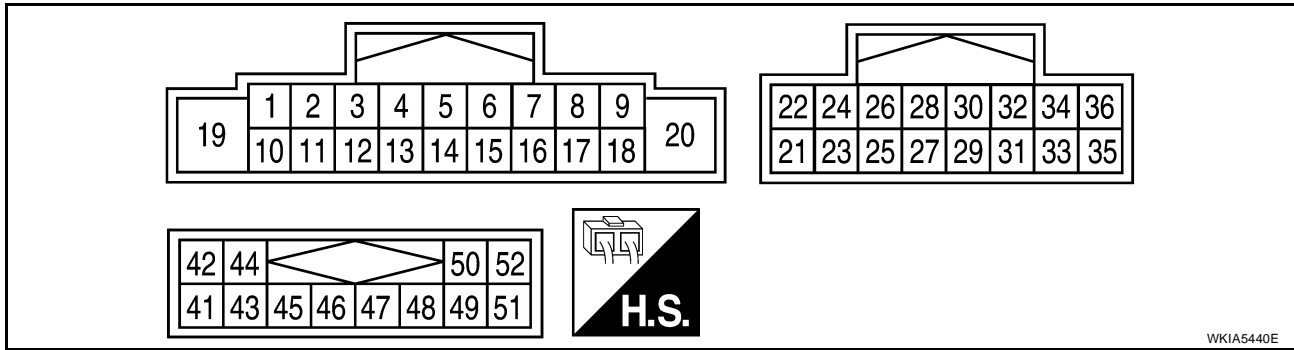

WKIA5440E

Terminals and Reference Value for Audio Unit (Mid Level and Premium System)

EKS0019O

Terminal (Wire color)		Item	Signal input/ output	Condition		Reference value (Approx.)	Example of symp- tom
+	-			Ignition switch	Operation		
2 (W)	3 (BR)	Audio sound signal front LH	Output	ON	Receive audio signal	 SKIA0177E	No sound from front door speaker LH or tweeter LH.
4 (V)	5 (R)	Audio sound signal rear LH	Output	ON	Receive audio signal	 SKIA0177E	No sound from rear door speaker LH or subwoofer LH.
6 (L)*2	Ground	Remote control A	Input	ON	Press Phone/ End switch	0V	Steering wheel audio controls do not function
					Press SEEK UP switch	1.7V	
					Press VOL UP switch	3.3V	
					Except for above	5.0V	
7 (LG)	Ground	ACC signal	Input	ON	Ignition switch ACC or ON	Battery voltage	System does not work properly.
11 (G)	12 (SB)	Audio sound signal front RH	Output	ON	Receive audio signal	 SKIA0177E	No sound from front door speaker RH or tweeter RH.

AUDIO

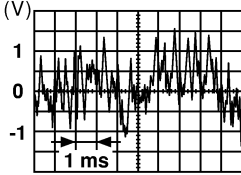
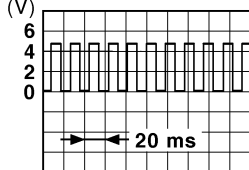
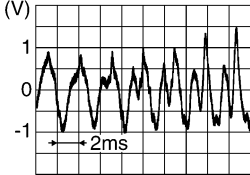
Terminal (Wire color)		Item	Signal input/ output	Condition		Reference value (Approx.)	Example of symp- tom
+	-			Ignition switch	Operation		
13 (LG)	14 (GR)	Audio sound signal rear RH	Output	ON	Receive audio signal	 <small>SKIA0177E</small>	No sound from rear door speaker RH or subwoofer RH.
15 (B)*2	-	Remote control ground	Input	-	-	-	Steering wheel audio controls do not function
16 (P)*2	Ground	Remote control B	Input	ON	Press Phone/ Send switch	0V	Steering wheel audio controls do not function
					Press SEEK DOWN switch	1.7V	
					Press VOL DOWN switch	3.3V	
					Except for above	5.0V	
18 (SB)	Ground	Vehicle speed sig- nal (8- pulse)	Input	ON	When vehicle speed is approx. 40 km/h (25 MPH)	 <small>PKIC0643E</small>	Speed sensitive volume is inopera- tive.
19 (BR)	Ground	Battery power	Input	-	-	Battery voltage	Subwoofer will not work properly.
21 (B)*2	Ground	EQ selec- tion	-	ON	-	0V (with mid level) 12V (with premium)	Wrong EQ will cause sub woofer to be inoperative
22*1	-	Shield	-	-	-	-	-
26 (R)*1	24 (G)	Audio sig- nal sub- woofer	Input	-	-	Audio signal	Subwoofer will not work properly.
28 (BR)*1	Ground	Subwoofer amp. ON signal	Output	ON	-	12V	Subwoofer will not work properly.
27 (O)*2	-	Bluetooth ON	Output	ON	Audio unit sends power signal to Blue- tooth control unit	-	Mute inoperative
31 (LG)*2	33 (V)*2	Audio out	Output	ACC/ ON	Audio unit receives audio signal from Bluetooth con- trol unit	 <small>SKIB3609E</small>	Bluetooth can not be heard.
35*2	-	Shield	-	-	-	-	-

AUDIO

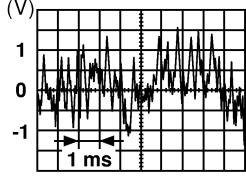
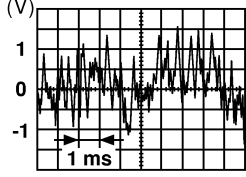
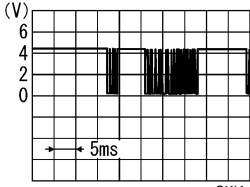
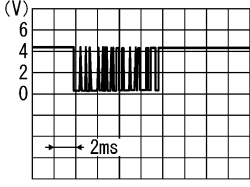
Terminal (Wire color)		Item	Signal input/ output	Condition		Reference value (Approx.)	Example of symp- tom
+	-			Ignition switch	Operation		
42 (R)	41 (G)	Audio left channel sound sig- nal from sat- ellite radio tuner	Input	ON	Receive audio signal	 SKIA0177E	No sound from satellite radio tuner left chan- nel.
44 (B)	43 (W)	Audio right channel sound sig- nal from sat- ellite radio tuner	Input	ON	Receive audio signal	 SKIA0177E	No sound from satellite radio tuner right chan- nel.
45	-	Shield ground (audio sig- nal)	-	-	-	0V	-
46	-	Shield ground (data)	-	-	-	0V	-
48 (B)	Ground	Satellite radio tuner request to audio unit	Input	ON	Turn audio unit ON	5V	Satellite radio tuner does not operate properly.
49 (L)	Ground	Audio RX	Input	ON	Operate audio volume	 SKIA4403E	Satellite radio tuner audio infor- mation does not display properly.
50 (Y)	Ground	Audio TX	Output	ON	Operate audio volume	 SKIA4402E	Satellite radio tuner audio infor- mation does not display properly.

*1: With premium system

*2: With Bluetooth

A
B
C
D
E
F
G
H
I
J
L
M

AV

AUDIO

Subwoofer Harness Connector Terminal Layout (Premium Audio System)

EKS001AT

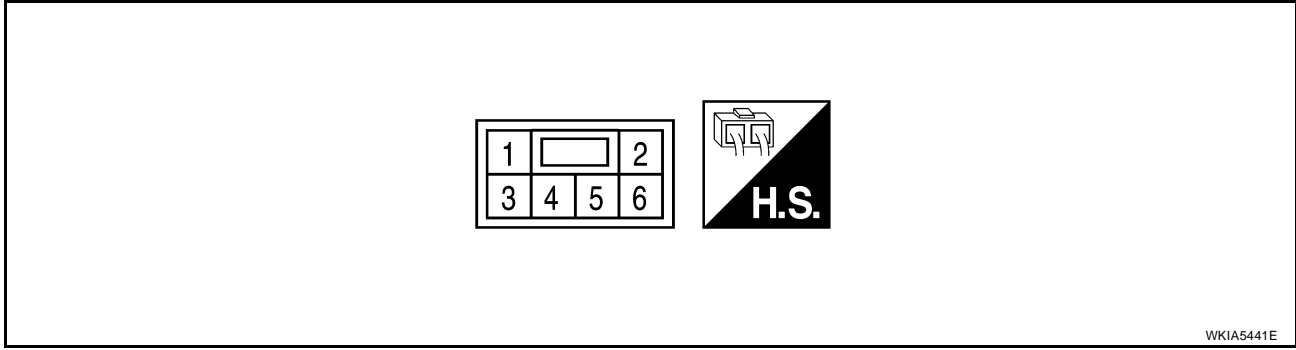

WKIA5441E

Terminals and Reference Value for Subwoofer (Premium Audio System)

EKS001AU

Terminal (Wire color)		Item	Signal input/ output	Condition		Reference value (Approx.)
+	-			Ignition switch	Operation	
1 (R)	Ground	Battery power supply	Input	OFF	-	Battery voltage
2 (O/L)	6 (W/L)	Audio signal sub- woofer	Input	ON	Receive audio signal	
3 (B)	Ground	Ground	-	ON	-	0 V
4 (LG)	Ground	Subwoofer amp. ON signal	Input	ON	-	Battery voltage
5	-	Shield	-	-	-	-

SKIB3609E

AUDIO

Satellite Radio Tuner Harness Connector Terminal Layout

EKS0019R

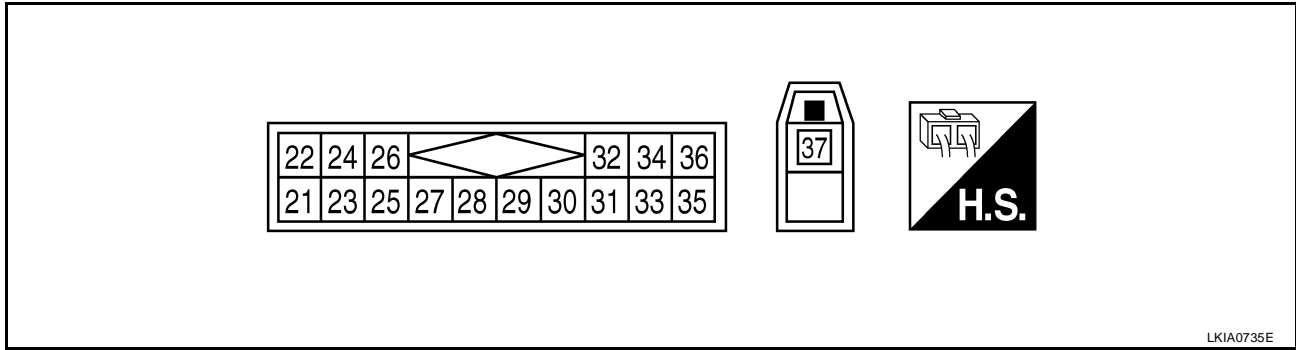

LKIA0735E

Terminals and Reference Value for Satellite Radio Tuner

EKS0019S

Terminal (Wire color)		Item	Signal input/ output	Condition		Voltage (Approx.)
+	-			Ignition switch	Operation	
22 (R)	21 (G)	Audio signal LH	Output	ON	Receive audio signal.	 SKIB3609E
24 (B)	23 (W)	Audio signal RH	Output	ON	Receive audio signal.	 SKIB3609E
25	-	Shield	-	-	-	-
26	-	Data ground	-	ON	-	0V
28 (B)	Ground	REQ1 (SAT-AUDIO)	Output	ON	Set to the satellite radio mode	 SKIB3825E
29 (R/L)	Ground	Communication signal (SAT-AUDIO)	Output	ON	Set to the satellite radio mode	 SKIB3824E
30 (R/W)	Ground	Communication signal (AUDIO-SAT)	Input	ON	Set to the satellite radio mode	 SKIB3826E

AUDIO

Terminal (Wire color)		Item	Signal input/ output	Condition		Voltage (Approx.)
+	-			Ignition switch	Operation	
32 (R)	Ground	Battery power supply	Input	OFF	-	Battery voltage
36 (L)		ACC power supply		ACC		
37	-	Antenna signal		-	-	-

AUDIO

EKS0014F

Trouble Diagnosis

NOTE:

The subwoofer (premium system) may be inoperative if the audio unit harness connectors have not been connected in the proper sequence (when the battery remains connected). The proper sequence is to connect M44 and M45 first followed by M43 last. If the subwoofer is inoperative, be sure to check this condition. Refer to [AV-40, "Sound Is Not Heard From Subwoofer \(Premium System\)"](#).

- The majority of the audio malfunctions are the result of outside causes (damaged CD, electromagnetic interference, etc.). Check the symptoms below to diagnose the malfunction.
- The vehicle itself can be a source of noise if noise prevention parts or electrical equipment is malfunctioning. Check if noise is caused and/or changed by engine speed, ignition switch turned to each position, and operation of each piece of electrical equipment, and then determine the cause.

Symptom	Check item
Audio system does not work properly.	<ul style="list-style-type: none">● Audio unit power supply circuit. Refer to AV-24, "Power Supply Circuit Inspection".● Audio unit. Refer to AV-23, "Trouble Diagnosis".
No sound can be heard from all speakers.	Audio unit. Refer to AV-23, "Trouble Diagnosis" .
No sound can be heard from one or several speakers.	<ul style="list-style-type: none">● Open or short in audio signal circuit between audio unit and front speaker. Refer to AV-32, "Sound Is Not Heard From Front Door Speaker (Base System)" or AV-36, "Sound Is Not Heard From Front Door Speaker or Tweeter (Mid Level and Premium System)".● Front speaker. Refer to AV-32, "Sound Is Not Heard From Front Door Speaker (Base System)" or AV-36, "Sound Is Not Heard From Front Door Speaker or Tweeter (Mid Level and Premium System)".● Open or short in audio signal circuit between audio unit and rear speaker. Refer to AV-34, "Sound Is Not Heard From Rear Door Speaker (Base System)" or AV-38, "Sound Is Not Heard From Rear Door Speaker (Mid Level and Premium System)".● Rear speaker. Refer to AV-34, "Sound Is Not Heard From Rear Door Speaker (Base System)" or AV-38, "Sound Is Not Heard From Rear Door Speaker (Mid Level and Premium System)".● Tweeter (mid level and premium system) AV-36, "Sound Is Not Heard From Front Door Speaker or Tweeter (Mid Level and Premium System)" or AV-38, "Sound Is Not Heard From Rear Door Speaker (Mid Level and Premium System)".● Subwoofer (premium system). Refer to AV-40, "Sound Is Not Heard From Subwoofer (Premium System)".● Audio unit. Refer to AV-24, "Power Supply Circuit Inspection".
No sound can be heard from radio or noise is heard.	<ul style="list-style-type: none">● Antenna feeder. Refer to AV-48, "AUDIO ANTENNA".● Antenna. Refer to AV-48, "AUDIO ANTENNA".● Audio unit. Refer to AV-24, "Power Supply Circuit Inspection".

NOTE:

Noise resulting from variations in field strength, such as fading noise and multi-path noise, or external noise from trains and other sources. It is not a malfunction.

- Fading noise: This noise occurs because of variations in the field strength in a narrow range due to mountains or buildings blocking the signal.
- Multi-path noise: This noise results from the waves sent directly from the broadcast station arriving at the antenna at a different time from the waves that reflect off of mountains or buildings.

Noise Inspection

EKS0019T

The vehicle itself can be a source of noise if noise prevention parts or electrical equipment is malfunctioning. Check if noise is caused and/or changed by engine speed, ignition switch turned to each position, and operation of each piece of electrical equipment, and determine the cause.

AUDIO

NOTE:

The source of the noise can be found easily by listening to the noise while removing the fuses of electrical components, one by one.

TYPE OF NOISE AND POSSIBLE CAUSE

	Occurrence condition	Possible cause
Occurs only when engine is ON.	A continuous growling noise occurs. The speed of the noise varies with changes in the engine speed.	Ignition components
	A whistling noise occurs while the engine speed is high. A booming noise occurs while the engine is running and the lighting switch is ON.	Generator
Noise only occurs when various electrical components are operating.	A cracking or snapping sound occurs with the operation of various switches.	Relay malfunction, radio malfunction
	The noise occurs when various motors are operating.	<ul style="list-style-type: none"> ● Motor case ground ● Motor
The noise occurs constantly, not just under certain conditions.		<ul style="list-style-type: none"> ● Rear defogger coil malfunction ● Open circuit in printed heater
A cracking or snapping sound occurs while the vehicle is being driven, especially when it is vibrating excessively.		<ul style="list-style-type: none"> ● Ground wire of body parts. ● Ground due to improper part installation ● Wiring connections or a short circuit

Power Supply Circuit Inspection

EKS0019U

1. CHECK FUSE

Check that the following fuses of the subwoofer (premium system) and audio unit are not blown.

Unit	Terminals	Signal name	Fuse No.
Audio unit	19	Battery power	27
	7	Ignition switch ACC or ON	20
Subwoofer (with premium audio)	1	Ignition switch ACC or ON	27

OK or NG

OK >> GO TO 2.

NG >> If fuse is blown, be sure to eliminate cause of blown fuse before installing new fuse. Refer to [PG-4, "POWER SUPPLY ROUTING CIRCUIT"](#).

2. AUDIO UNIT POWER SUPPLY CIRCUIT CHECK

1. Disconnect audio unit connector.
2. Check voltage between the audio unit and ground.

Unit	Terminal No.		OFF	ACC	ON
	(+)				
	Connector	Terminal			
Audio unit	M43	19	Ground	Battery voltage	Battery voltage
		7	Ground	0V	Battery voltage

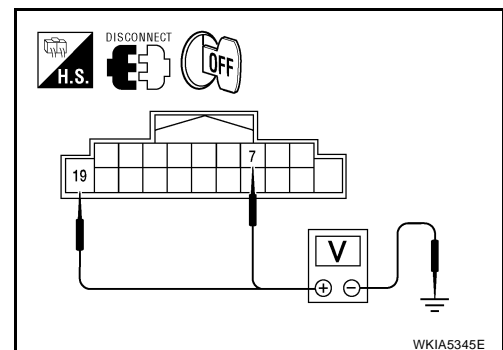

OK or NG

OK >> With premium system, GO TO 3.

NG >> ● Check connector housings for disconnected or loose terminals.

- Repair harness or connector.

AUDIO

3. SUBWOOFER (PREMIUM SYSTEM) POWER SUPPLY CIRCUIT CHECK

1. Disconnect subwoofer connector.
2. Check voltage between subwoofer (premium system) and ground.

Unit	Terminal No.			OFF	ACC	ON
	(+)		(-)			
	Connector	Terminal				
Sub-woofer	B29	1	Ground	0V	Battery voltage	Battery voltage

OK or NG

- OK >> GO TO 4.
 NG >> ● Check connector housings for disconnected or loose terminals.
 ● Repair harness or connector.

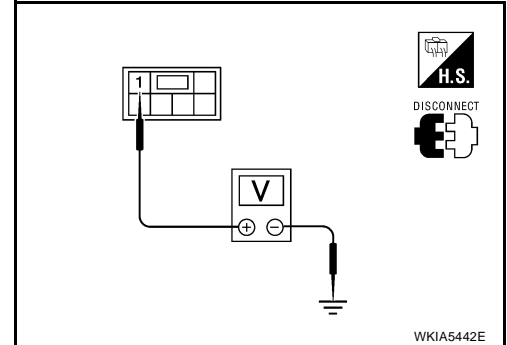

4. GROUND CIRCUIT CHECK

Check continuity between subwoofer (premium system) harness connector B29 terminal 3 and ground.

Continuity should exist.

OK or NG

- OK >> Inspection End.
 NG >> ● Check connector housings for disconnected or loose terminals.
 ● Repair harness or connector.

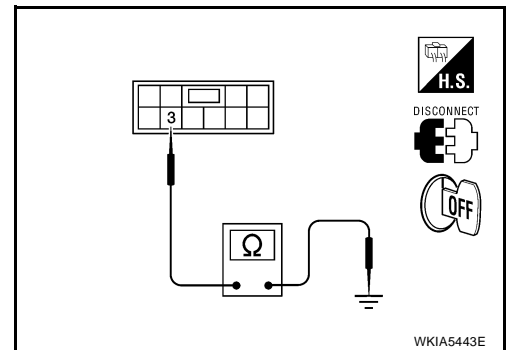

Satellite Radio Tuner (Factory Installed) Power and Ground Supply Circuit Inspection

EKS0019V

1. CHECK FUSES

Check that the following fuses are not blown.

Unit	Terminals	Signal name	Fuse No.
Satellite radio tuner (factory installed)	32	Battery power	27
	36	Ignition switch ACC or ON	20

OK or NG

- OK >> GO TO 2.
 NG >> If fuse is blown, be sure to eliminate cause of blown fuse before installing new fuse. Refer to [PG-4, "POWER SUPPLY ROUTING CIRCUIT"](#).

AUDIO

2. POWER SUPPLY CIRCUIT CHECK

1. Turn ignition switch OFF.
2. Disconnect satellite radio tuner (factory installed) connector B30.
3. Check voltage between the satellite radio tuner (factory installed) and ground.

Unit	Terminal No.		OFF	ACC	ON	
	(+)					(-)
	Connector	Terminal				
Satellite radio tuner (factory installed)	B30	32	Battery voltage	Battery voltage	Battery voltage	
		36	0V	Battery voltage	Battery voltage	

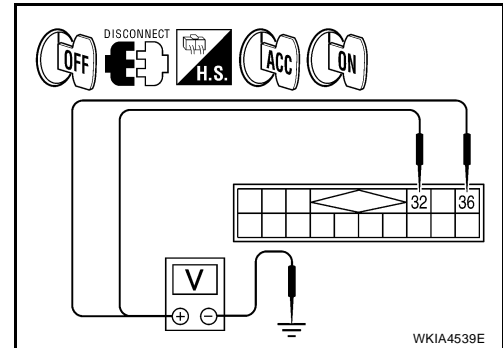

OK or NG

- OK >> GO TO 3.
 NG >> ● Check connector housings for disconnected or loose terminals.
 ● Repair harness or connector.

3. GROUND CIRCUIT CHECK

1. Turn ignition switch OFF.
2. Inspect satellite radio tuner (factory installed) case ground.
3. Disconnect satellite radio tuner (factory installed) connector B30 (A) and audio unit connector M45 (B).
4. Check continuity between satellite radio tuner (factory installed) and audio unit.

Terminals				Continuity
Satellite radio tuner		Audio unit		
Connector	Terminal	Connector	Terminal	
A: B30	25	B: M45	45	Yes
	26		46	

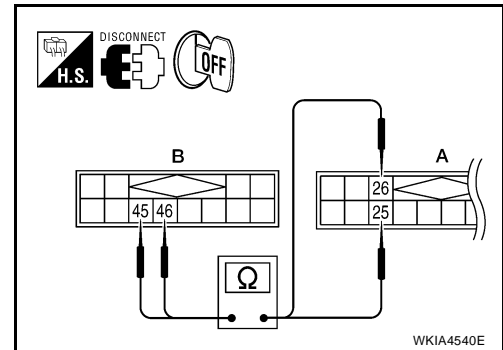

OK or NG

- OK >> Inspection End.
 NG >> ● Check connector housings for disconnected or loose terminals.
 ● Repair harness, connector or satellite radio tuner (factory installed) case ground.

Satellite Radio Tuner (Factory Installed) Communication Circuit Inspection

EKS0019W

1. CHECK HARNESS - 1

1. Turn ignition switch OFF.
2. Disconnect satellite radio tuner (factory installed) connector B30 and audio unit connector M45.
3. Check continuity between satellite radio tuner (factory installed) harness connector B30 (A) terminal 28 and audio unit harness connector M45 (B) terminal 48

Continuity should exist.

4. Check continuity between satellite radio tuner (factory installed) harness connector B30 (A) terminal 28 and ground.

Continuity should not exist.

OK or NG

- OK >> GO TO 2.
 NG >> Repair harness or connector.

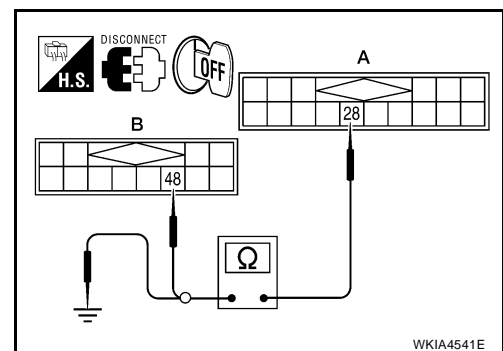

AUDIO

2. CHECK HARNESS - 2

1. Check continuity between satellite radio tuner (factory installed) harness connector B30 (A) terminal 29 and audio unit harness connector M45 (B) terminal 49

Continuity should exist.

2. Check continuity between satellite radio tuner (factory installed) harness connector B30 (A) terminal 29 and ground.

Continuity should not exist.

OK or NG

- OK >> GO TO 3.
- NG >> Repair harness or connector.

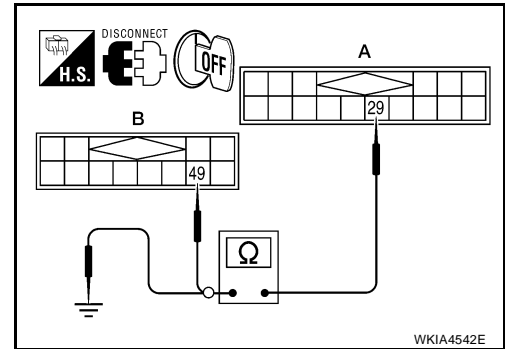

3. CHECK HARNESS - 3

1. Check continuity between satellite radio tuner (factory installed) harness connector B30 (A) terminal 30 and audio unit harness connector M45 (B) terminal 50

Continuity should exist.

2. Check continuity between satellite radio tuner (factory installed) harness connector B30 (A) terminal 30 and ground.

Continuity should not exist.

OK or NG

- OK >> GO TO 4.
- NG >> Repair harness or connector.

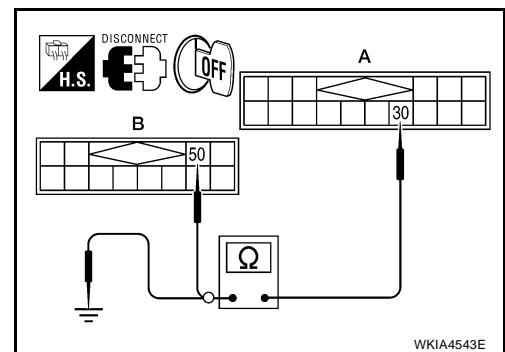

4. CHECK REQ1 SIGNAL

1. Connect satellite radio tuner (factory installed) connector and audio unit connector.
2. Turn ignition switch to ACC
3. Check signal between satellite radio tuner (factory installed) harness connector B30 terminal 28 and ground with CONSULT-II or oscilloscope.

28 - Ground : Refer to [AV-21, "Terminals and Reference Value for Satellite Radio Tuner"](#) .

OK or NG

- OK >> GO TO 5.
- NG >> Replace audio unit. Refer to [AV-43, "AUDIO UNIT"](#) .

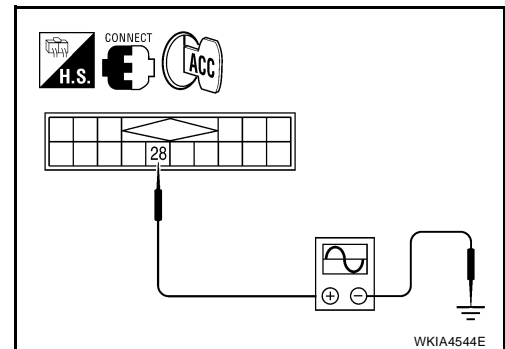

5. CHECK TXD SIGNAL

Check signal between satellite radio tuner (factory installed) harness connector B30 terminal 29 and ground with CONSULT-II or oscilloscope.

29 - Ground : Refer to [AV-21, "Terminals and Reference Value for Satellite Radio Tuner"](#) .

OK or NG

- OK >> GO TO 6.
- NG >> Replace audio unit. Refer to [AV-43, "AUDIO UNIT"](#) .

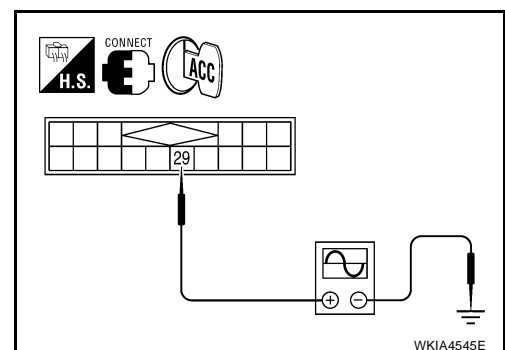

AUDIO

6. CHECK RXD SIGNAL

Check signal between satellite radio tuner (factory installed) harness connector B30 terminal 30 and ground with CONSULT-II or oscilloscope.

30 - Ground : Refer to [AV-21, "Terminals and Reference Value for Satellite Radio Tuner"](#) .

OK or NG

OK >> Replace satellite radio tuner. Refer to [AV-44, "SATELLITE TUNER MODULE"](#) .

NG >> Replace audio unit. Refer to [AV-43, "AUDIO UNIT"](#) .

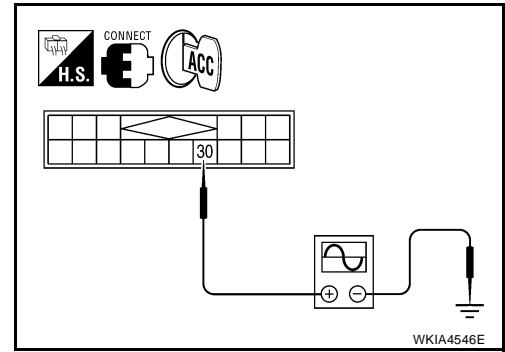

Satellite Radio Tuner (Factory Installed) Left Channel Audio Signal Inspection

EKS0019X

1. CHECK HARNESS

1. Turn ignition switch OFF.
2. Disconnect satellite radio tuner (factory installed) connector B30 (A) and audio unit connector M45 (B).
3. Check continuity between satellite radio tuner (factory installed) and audio unit.

Terminals				Continuity
Satellite radio tuner		Audio unit		
Connector	Terminal	Connector	Terminal	
A: B30	21	B: M45	41	Yes
	22		42	

4. Check continuity between satellite radio tuner (factory installed) and ground.

Terminals				Continuity
Satellite radio tuner		—		
Connector	Terminal			
A: B30	21	Ground		No
	22			

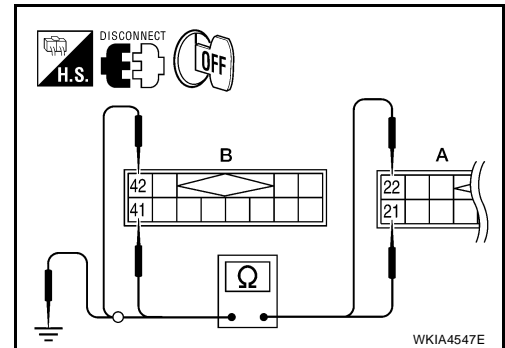

OK or NG

OK >> GO TO 2.

NG >> Repair harness or connector.

2. CHECK LEFT CHANNEL AUDIO SIGNAL

1. Connect satellite radio tuner (factory installed) and audio unit.
2. Turn ignition switch ON.
3. Check signal between satellite radio tuner (factory installed) connector B30 terminals 21 and 22 with CONSULT-II or oscilloscope.

21 - 22 : Refer to [AV-21, "Terminals and Reference Value for Satellite Radio Tuner"](#) .

OK or NG

OK >> Replace audio unit. Refer to [AV-43, "AUDIO UNIT"](#) .

NG >> Replace satellite radio tuner. Refer to [AV-44, "SATELLITE TUNER MODULE"](#) .

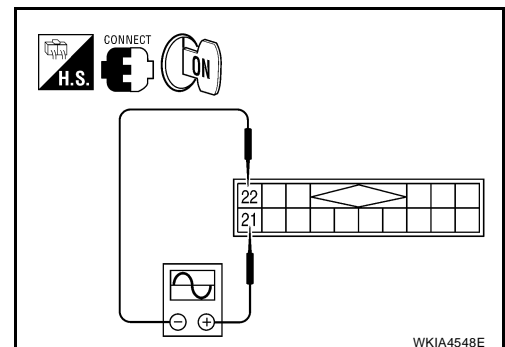

AUDIO

Satellite Radio Tuner (Factory Installed) Right Channel Audio Signal Circuit Inspection

EKS0019Y

1. CHECK HARNESS

1. Turn ignition switch OFF.
2. Disconnect satellite radio tuner (factory installed) connector B30 (A) and audio unit connector M45 (B).
3. Check continuity between satellite radio tuner (factory installed) and audio unit.

Terminals				Continuity
Satellite radio tuner		Audio unit		
Connector	Terminal	Connector	Terminal	
A: B30	23	B: M45	43	Yes
	24		44	

4. Check continuity between satellite radio tuner (factory installed) and ground.

Terminals				Continuity
Satellite radio tuner		—		
Connector	Terminal			
A: B30	23	Ground		No
	24			

OK or NG

- OK >> GO TO 2.
 NG >> Repair harness or connector.

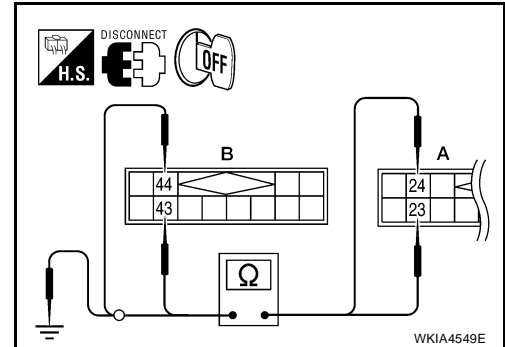

2. CHECK RIGHT CHANNEL AUDIO SIGNAL

1. Connect satellite radio tuner (factory installed) and audio unit.
2. Turn ignition switch ON.
3. Check signal between satellite radio tuner (factory installed) connector B30 terminals 23 and 24 with CONSULT-II or oscilloscope.

23 - 24

: Refer to [AV-21, "Terminals and Reference Value for Satellite Radio Tuner"](#) .

OK or NG

- OK >> Replace audio unit. Refer to [AV-43, "AUDIO UNIT"](#) .
 NG >> Replace satellite radio tuner. Refer to [AV-44, "SATELLITE TUNER MODULE"](#) .

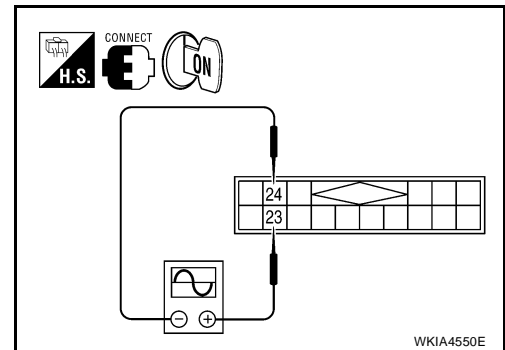

AUDIO

EKS0019Z

Steering Switch Check (With Bluetooth)

1. CHECK HARNESS

1. Turn ignition switch OFF.
2. Disconnect Bluetooth control unit connector and spiral cable connector M30.
3. Check continuity between Bluetooth control unit (A) connector B121 terminals 12, 14, and 13 and spiral cable (B) connector M30 terminals 24, 31, and 32.

Terminals				Continuity
A		B		
Connector	Terminal	Connector	Terminal	
B121	12	M30	24	Yes
	13		32	
	14		31	

4. Check continuity between Bluetooth control unit and ground.

Terminals			Continuity
(+)		(-)	
Connector	Terminal		
B121	12	Ground	No
	13		
	14		

OK or NG

OK >> GO TO 3.

NG >> Repair harness.

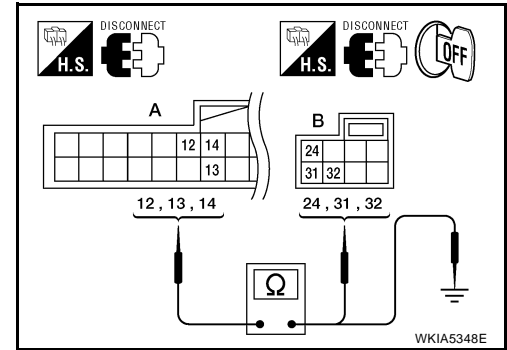

2. CHECK HARNESS

1. Disconnect audio unit connector.
2. Check continuity between audio unit (A) connector M43 terminals 6, 15, and 16 and Bluetooth control unit (B) connector B121 terminals 17, 19, and 18.

Terminals				Continuity
(A)		(B)		
Connector	Terminal	Connector	Terminal	
M43	6	B121	17	Yes
	15		19	
	16		18	

OK or NG

OK >> GO TO 4.

NG >> Repair harness.

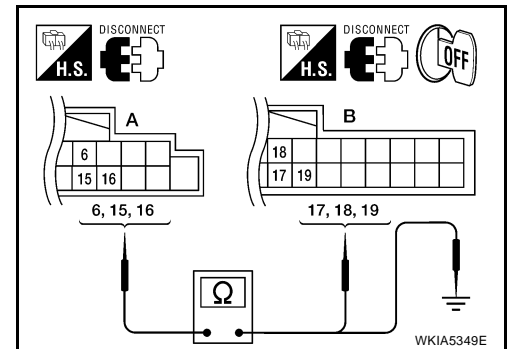

AUDIO

3. SPIRAL CABLE CHECK

1. Disconnect spiral cable connector M102.
2. Check continuity between spiral cable terminals.

16 - 32 : Continuity should exist.
17 - 31 : Continuity should exist.
20 - 24 : Continuity should exist.

OK or NG

OK >> GO TO 4.

NG >> Replace spiral cable. Refer to [SRS-44, "Removal and Installation"](#) .

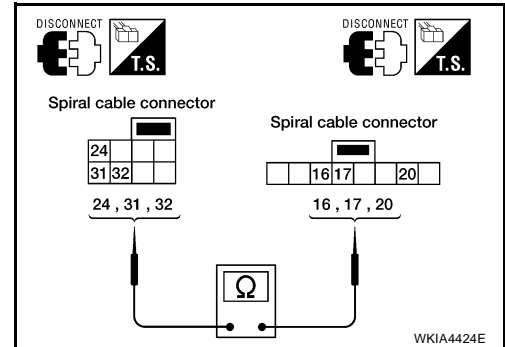

4. CHECK STEERING SWITCH RESISTANCE

Check resistance between spiral cable connector M102 terminals.

Terminal	Signal name	Condition	Resistance (Ω) (Approx.)	
16	17	Seek (down)	Depress Seek down switch.	165
		Phone/Send	Depress Phone/Send switch.	0
		Volume (down)	Depress volume down switch.	487
20	17	Seek (up)	Depress Seek up switch.	165
		Phone/End	Depress Phone/End switch.	0
		Volume (up)	Depress volume up switch.	487

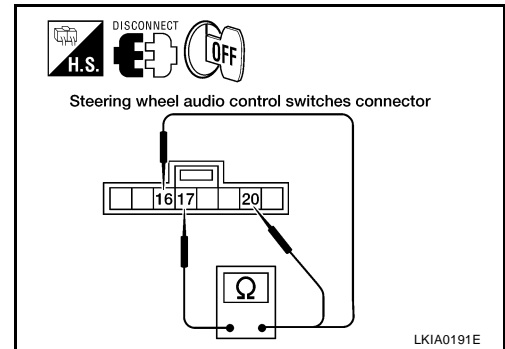

OK or NG

OK >> Inspection End.

NG >> Replace steering switch. Refer to [AV-46, "STEERING WHEEL AUDIO CONTROL SWITCHES"](#) .

AUDIO

EKS001A0

Sound Is Not Heard From Front Door Speaker (Base System)

1. HARNESS CHECK

1. Disconnect audio unit connector and front door speaker connector (LH or RH).
2. Check continuity between audio unit connector M43 (A) terminal and suspect speaker connector (B) terminal.

Terminals				Continuity
A		B		
Connector	Terminal	Connector	Terminal	
M43	2	D12	+	Yes
	3		-	
	11	D112	+	
	12		-	

3. Check continuity between audio unit connector M43 terminal and ground.

Terminals			Continuity
Audio unit		—	
Connector	Terminal		
M43	2	Ground	No
	3		
	11		
	12		

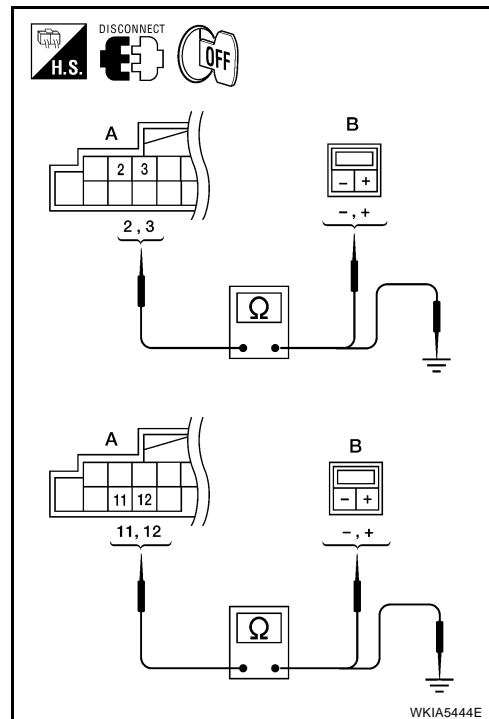

OK or NG

- OK >> GO TO 2.
- NG >> ● Check connector housings for disconnected or loose terminals.
 ● Repair harness or connector.

AUDIO

2. FRONT SPEAKER SIGNAL CHECK

1. Connect audio unit connector and suspect speaker connector.
2. Turn ignition switch to ACC.
3. Push "POWER" switch.
4. Check the signal between audio unit harness connector terminals with CONSULT-II or oscilloscope.

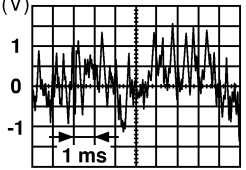
Terminals				Condi- tion	Reference signal
(+)		(-)			
Con- nec- tor	Termi- nal	Con- nec- tor	Termi- nal		
M43	2	M43	3	Receive audio signal	
	11		12		

SKIA0177E

OK or NG

- OK >> Replace speaker. Refer to [AV-43, "FRONT DOOR SPEAKER"](#) or [AV-43, "TWEETER"](#) .
- NG >> Replace audio unit. Refer to [AV-43, "AUDIO UNIT"](#) .

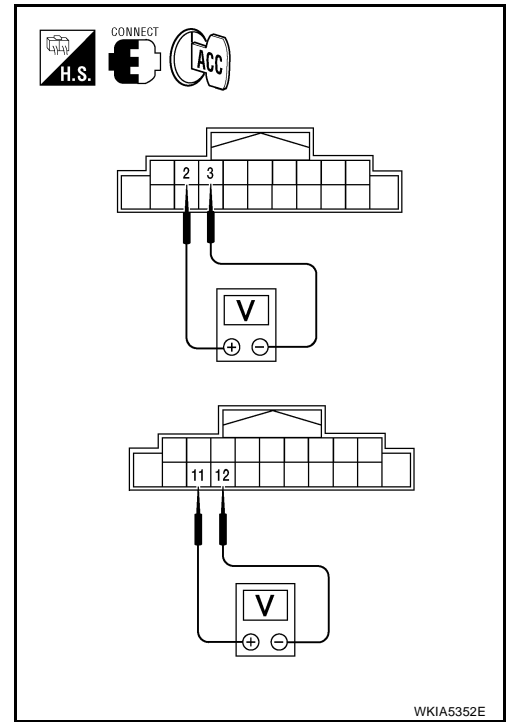

WKIA5352E

A
B
C
D
E
F
G
H
I
J
L
M

AV

AUDIO

EKS001A1

Sound Is Not Heard From Rear Door Speaker (Base System)

1. HARNESS CHECK

1. Disconnect audio unit connector and rear door speaker connector.
2. Check continuity between audio unit (A) connector terminal and rear door speaker (B) connector terminal.

Terminals				Continuity
A		B		
Connector	Terminal	Connector	Terminal	
M43	5	D207	-	Yes
	4		+	
	14	D307	-	
	13		+	

3. Check continuity between audio unit harness connector terminal and ground.

Terminals				Continuity
Audio unit		—		
Connector	Terminal			
M43	5	Ground		No
	4			
	14			
	13			

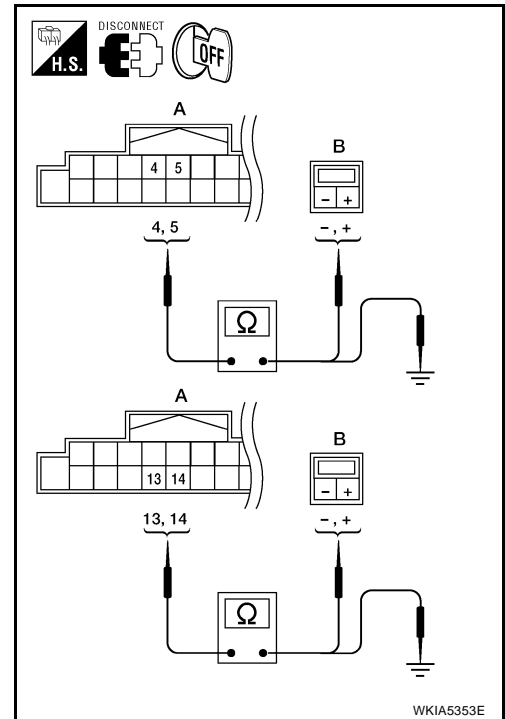

OK or NG

- OK >> GO TO 2.
 NG >> ● Check connector housings for disconnected or loose terminals.
 ● Repair harness or connector.

AUDIO

2. REAR SPEAKER SIGNAL CHECK

1. Connect audio unit connector and rear speaker connector.
2. Turn ignition switch to ACC.
3. Push "POWER" switch.
4. Check the signal between audio unit harness connector terminals with CONSULT-II or oscilloscope.

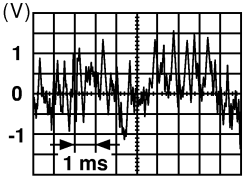
Terminals				Condition	Reference signal
(+)		(-)			
Con- nector	Termi- nal	Con- nector	Termi- nal		
M43	4	M43	5	Receive audio signal	
	13		14		

SKIA0177E

OK or NG

- OK >> Replace speaker. Refer to [AV-43, "REAR DOOR SPEAKER"](#) .
- NG >> Replace audio unit. Refer to [AV-43, "AUDIO UNIT"](#) .

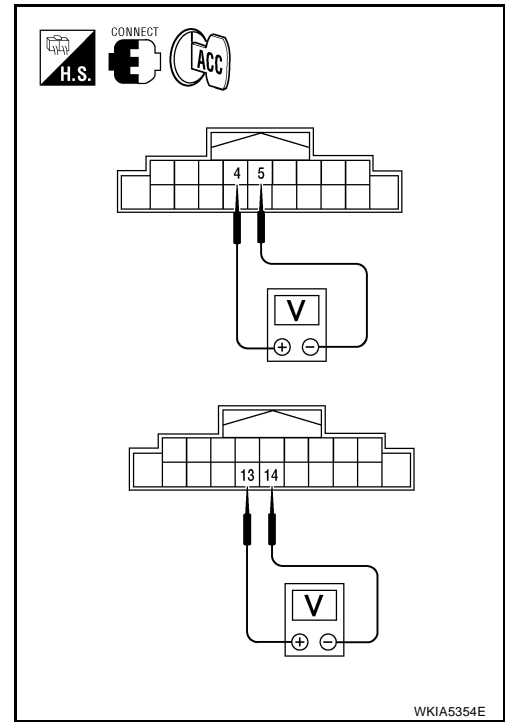

WKIA5354E

A
B
C
D
E
F
G
H
I
J
L
M

AV

AUDIO

EKS00IA2

Sound Is Not Heard From Front Door Speaker or Tweeter (Mid Level and Premium System)

1. HARNESS CHECK

1. Disconnect audio unit connector and front door speaker and tweeter connector (LH or RH).
2. Check continuity between audio unit harness connector terminal and front door speaker and tweeter harness connector terminal.

Terminals				Continuity
Audio unit.		Speaker or tweeter		
Connector	Terminal	Connector	Terminal	
M43	2	M46	+	Yes
	3		-	
	11	M47	+	
	12		-	
	2	D12	+	
	3		-	
	11	D112	+	
	12		-	

3. Check continuity between audio unit harness connector terminal and ground.

Terminals				Continuity
Audio unit		—		
Connector	Terminal			
M43	2	Ground		No
	3			
	11			
	12			

OK or NG

OK >> GO TO 2.

NG >> ● Check connector housings for disconnected or loose terminals.

- Repair harness or connector.

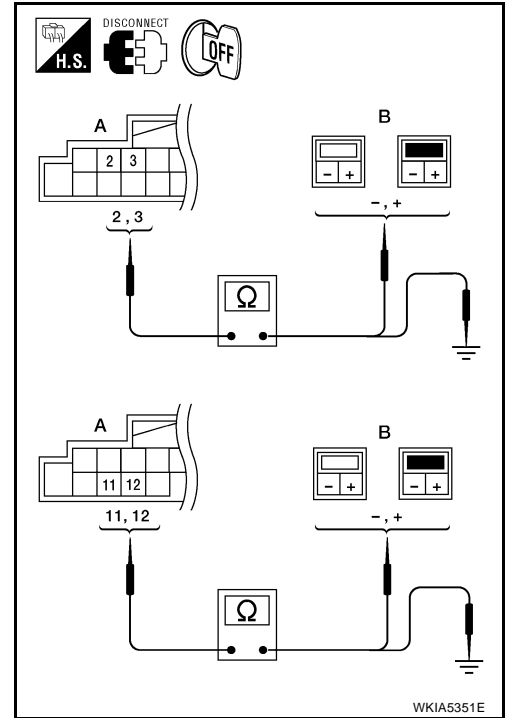

AUDIO

2. FRONT SPEAKER SIGNAL CHECK

1. Connect audio unit connector, front door speaker connector and tweeter connector.
2. Turn ignition switch to ACC.
3. Push "POWER" switch.
4. Check the signal between audio unit connector terminals with CONSULT-II or oscilloscope.

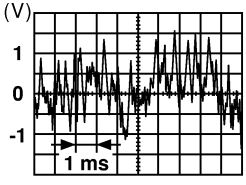
Terminals				Condi- tion	Reference signal
(+)		(-)			
Con- nector	Termi- nal	Con- nector	Termi- nal		
M51	2	M51	3	Receive audio signal	
	11		12		

SKIA0177E

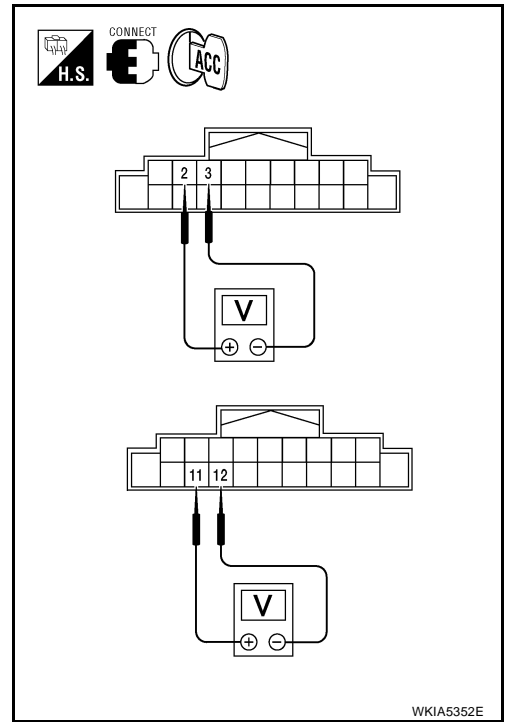

OK or NG

- OK >> Replace front speaker. Refer to [AV-43, "FRONT DOOR SPEAKER"](#) .
- NG >> Replace audio unit. Refer to [AV-43, "AUDIO UNIT"](#) .

A
B
C
D
E
F
G
H
I
J
L
M

AV

AUDIO

Sound Is Not Heard From Rear Door Speaker (Mid Level and Premium System)

EKS00IA3

1. HARNESS CHECK

1. Disconnect audio unit connector and rear door speaker connector.
2. Check continuity between audio unit harness connector terminal and speaker harness connector terminal.

Terminals				Continuity
Audio unit		Speaker		
Connector	Terminal	Connector	Terminal	
M43	4	D207	+	Yes
	5		-	
	13	D307	+	
	14		-	

3. Check continuity between audio unit harness connector terminal and ground.

Terminals			Continuity
Audio unit		—	
Connector	Terminal		
M43	4	Ground	No
	5		
	13		
	14		

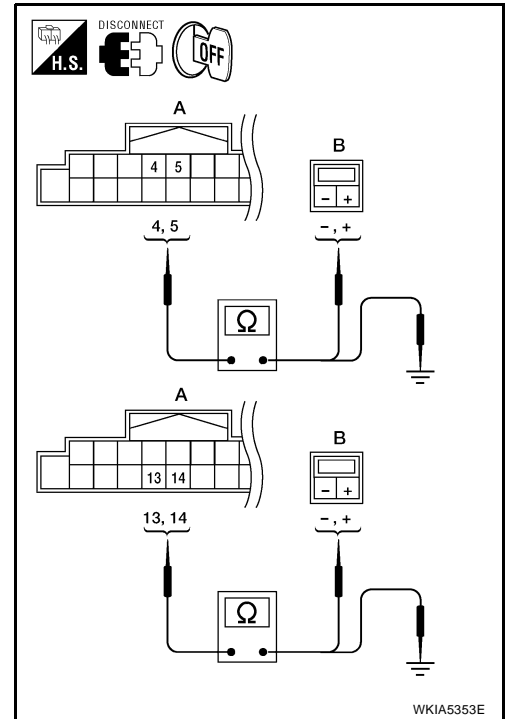

OK or NG

- OK >> GO TO 2.
 NG >> ● Check connector housings for disconnected or loose terminals.
 ● Repair harness or connector.

AUDIO

2. REAR SPEAKER SIGNAL CHECK

1. Connect audio unit connector and rear door speaker connector.
2. Turn ignition switch to ACC.
3. Push "POWER" switch.
4. Check the signal between audio unit harness connector terminals with CONSULT-II or oscilloscope.

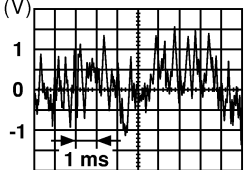
Terminals				Condi- tion	Reference signal
(+)		(-)			
Con- nec- tor	Termi- nal	Con- nec- tor	Termi- nal		
M43	5	M43	4	Receive audio signal	
	14		13		

SKIA0177E

OK or NG

- OK >> Replace speaker. Refer to [AV-43, "REAR DOOR SPEAKER"](#) .
- NG >> Replace audio unit. Refer to [AV-43, "AUDIO UNIT"](#) .

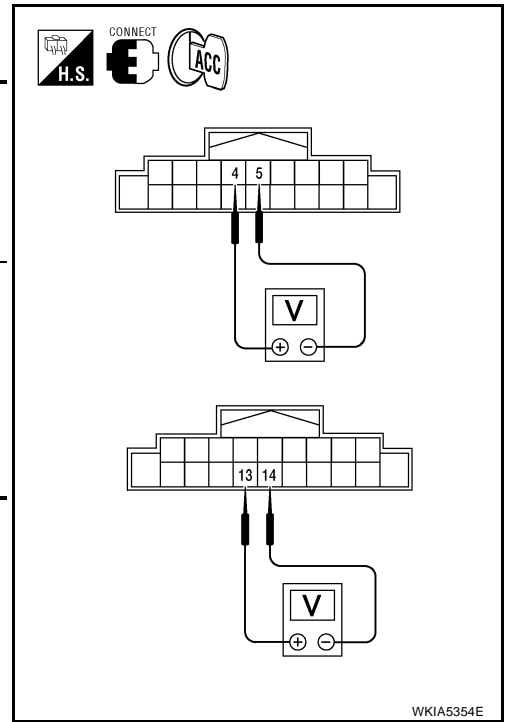

WKIA5354E

A
B
C
D
E
F
G
H
I
J
L
M

AV

AUDIO

EKS001A4

Sound Is Not Heard From Subwoofer (Premium System)

1. CHECK FUSE

Check that the following fuse is not blown.

Unit	Terminals	Signal name	Fuse No.
Subwoofer	1	Battery power	27

OK or NG

OK >> GO TO 2.

NG >> If fuse is blown, be sure to eliminate cause of blown fuse before installing new fuse. Refer to [PG-4, "POWER SUPPLY ROUTING CIRCUIT"](#).

2. EQ SETTING CHECK

1. Ensure that subwoofer amp. connector B29 and audio unit harness connectors M43, M44 and M45 are securely connected.
2. Turn the ignition switch to the ACC position.
3. Press the "AUDIO", "AUX", and "TUNE DOWN" switches simultaneously, the current EQ Setting will be displayed.

Is "Woofers On" displayed?

YES >> GO TO 3.

NO >> Disconnect all audio unit harness connectors and wait for 2 minutes in order to reset the audio unit. Reconnect audio unit connectors M44 and M45 first followed by M43 last. Repeat Steps 1 through 3 to confirm that "Woofers On" is now displayed.

3. POWER SUPPLY CIRCUIT CHECK

1. Turn ignition switch OFF.
2. Disconnect subwoofer connector.
3. Check voltage between the subwoofer and ground.

Unit	Terminal No.			OFF	ACC	ON
	(+)		(-)			
	Connector	Terminal				
Subwoofer	B29	1	Ground	Battery voltage	Battery voltage	Battery voltage

OK or NG

OK >> GO TO 4.

NG >> ● Check connector housings for disconnected or loose terminals.

- Repair harness or connector.

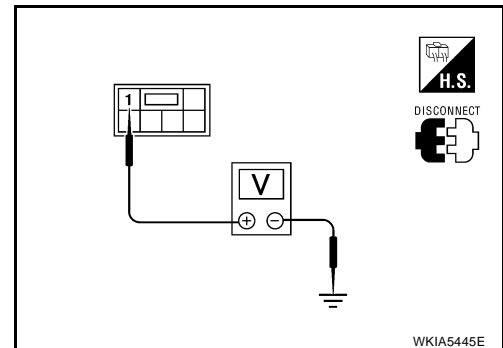

4. GROUND CIRCUIT CHECK

1. Turn ignition switch OFF.
2. Check continuity between subwoofer harness connector B29 terminal 3 and ground.

Continuity should exist.

OK or NG

OK >> GO TO 5.

NG >> ● Check connector housings for disconnected or loose terminals.

- Repair harness or connector.

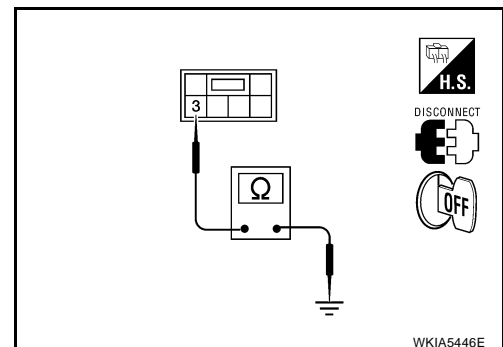

AUDIO

5. CHECK SUBWOOFER ON SIGNAL

1. Turn ignition switch to ACC.
2. Operate system and check voltage between subwoofer harness connector B29 terminal 4 and ground.

Voltage : Approx. 11.3V

OK or NG

- OK >> GO TO 6.
 NG >> ● Check connector housings for disconnected or loose terminals.
 ● Repair harness or connector.

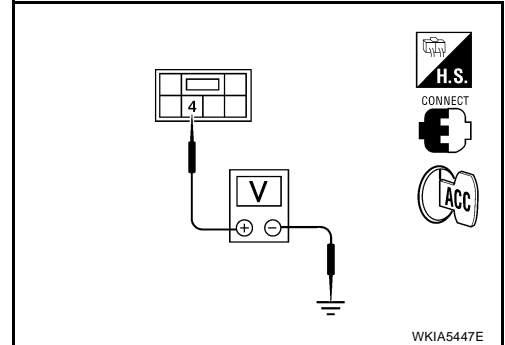

6. HARNESS CHECK

1. Turn ignition switch OFF.
2. Disconnect audio unit connector and subwoofer connectors.
3. Check continuity between audio unit harness connector terminal and subwoofer harness connector terminal.

Terminals				Continuity
Audio unit		Subwoofer		
Connector	Terminal	Connector	Terminal	
M44	24	B29	6	Yes
	26		2	

4. Check continuity between audio unit harness connector terminal and ground.

Terminals			Continuity
Audio unit		—	
Connector	Terminal		
M44	24	Ground	No
	26		

OK or NG

- OK >> GO TO 7.
 NG >> ● Check connector housings for disconnected or loose terminals.
 ● Repair harness or connector.

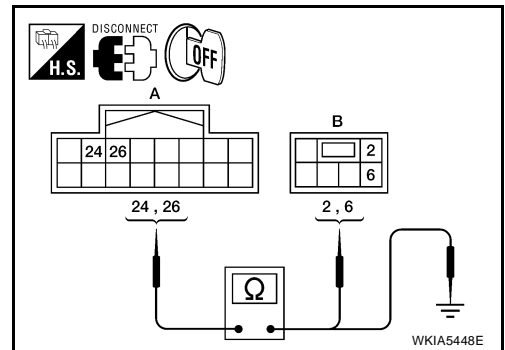

A
B
C
D
E
F
G
H
I
J
L
M

AV

AUDIO

7. SUBWOOFER SIGNAL CHECK

1. Connect audio unit connector and subwoofer connector.
2. Turn ignition switch to ACC.
3. Check the signal between audio unit harness connector terminals with CONSULT-II or oscilloscope.

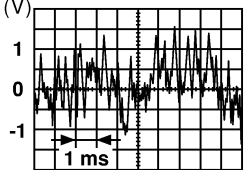
Terminals				Condi- tion	Reference signal
(+)		(-)			
Con- nec- tor	Ter- minal	Con- nec- tor	Ter- minal		
M44	26	M44	24	Receive audio signal	

SKIA0177E

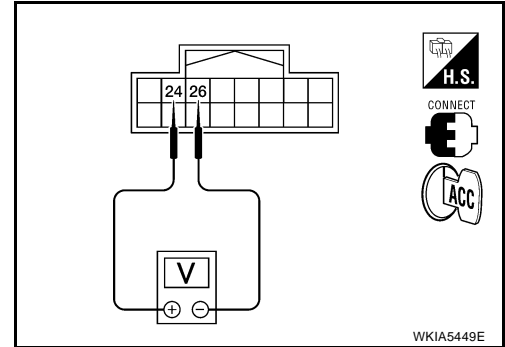

OK or NG

- OK >> Replace subwoofer. Refer to [AV-47, "SUBWOOFER"](#) .
- NG >> Replace audio unit. Refer to [AV-43, "AUDIO UNIT"](#) .

AUDIO

Removal and Installation

AUDIO UNIT

EKS0014G

Removal

1. Remove cluster lid C. Refer to [IP-10, "INSTRUMENT PANEL ASSEMBLY"](#).
2. Remove the audio unit screws (A), disconnect the connectors and remove the audio unit (1).
3. Remove the audio unit bracket.

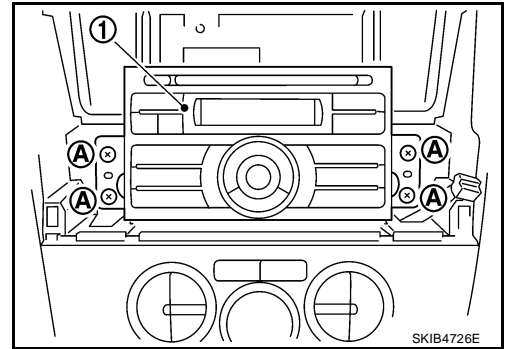

Installation

Installation is in the reverse order of removal.

FRONT DOOR SPEAKER

Removal

1. Remove the front door finisher. Refer to [EI-27, "DOOR FINISHER"](#).
2. Remove the front door speaker screws (A), disconnect the connector and remove the front door speaker (1).

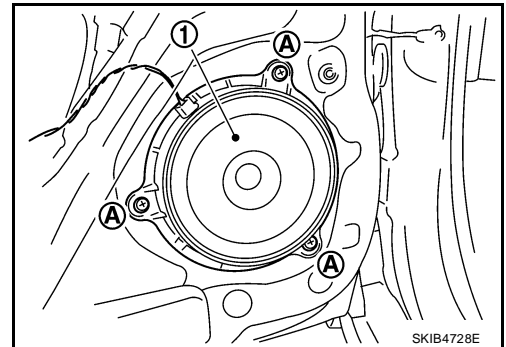

Installation

Installation is in the reverse order of removal.

REAR DOOR SPEAKER

Removal

1. Remove the rear door finisher. Refer to [EI-27, "DOOR FINISHER"](#).
2. Remove the rear door finisher screws (A), disconnect the connector and remove the rear door speaker (1).

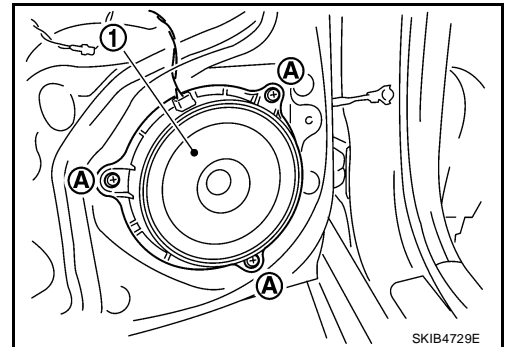

Installation

Installation is in the reverse order of removal.

TWEETER

Removal

1. Remove the front pillar garnish. Refer to [EI-32, "BODY SIDE TRIM"](#).

A
B
C
D
E
F
G
H
I
J

AV

L
M

AUDIO

2. Remove the tweeter screw (A), disconnect the connector and remove the tweeter (1).

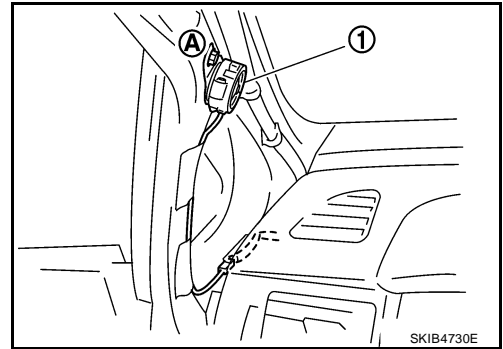

Installation

Installation is in the reverse order of removal.

SATELLITE TUNER MODULE

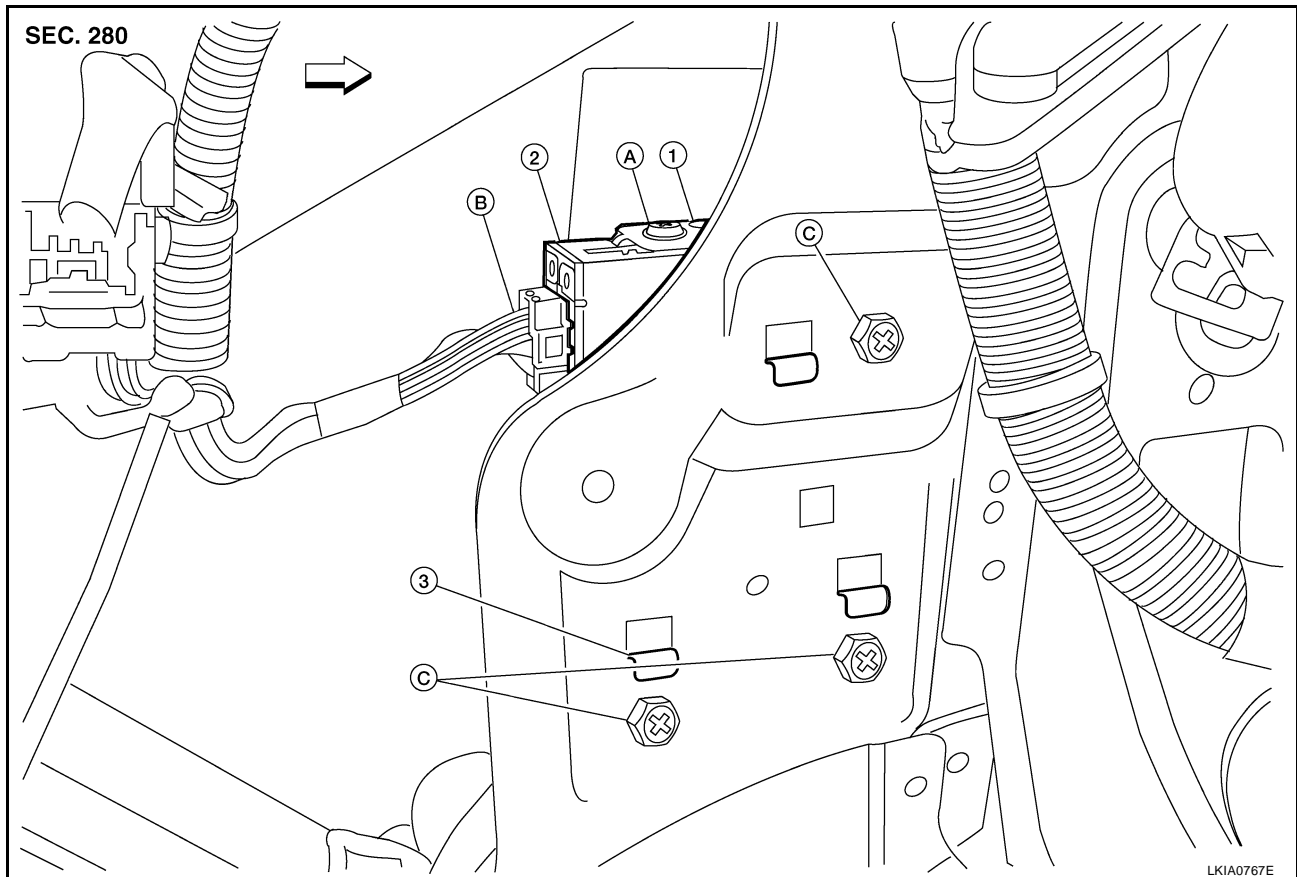

- | | | |
|--------------------|---------------------------|--------------------|
| 1. Bracket (upper) | 2. Satellite tuner module | 3. Bracket (lower) |
| A. Screws | B. Connector | C. Bolts |
| ⇒ Front | | |

Removal

1. Remove the luggage side lower finisher (LH). Refer to [EI-42, "LUGGAGE FLOOR TRIM"](#).
2. Remove the subwoofer. Refer to [AV-47, "SUBWOOFER"](#).
3. Remove the satellite module bolts.
4. Disconnect the connector and remove the satellite tuner module.

AUDIO

5. If necessary, remove the upper bracket (2) and the lower bracket (1).

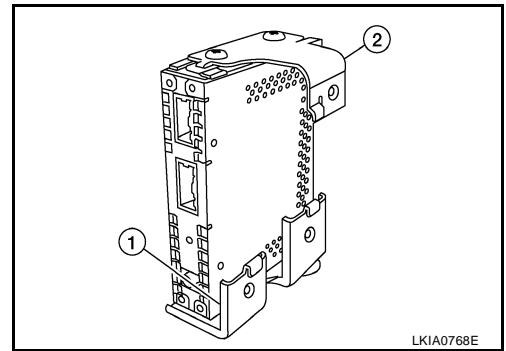

Installation

Installation is in the reverse order of removal.

SATELLITE TUNER ANTENNA

Removal

1. Lower the headlining. Refer to [EI-39, "HEADLINING"](#).
2. Disconnect the satellite tuner antenna connectors.
3. Remove the satellite tuner antenna nut and remove the satellite tuner antenna from the roof.

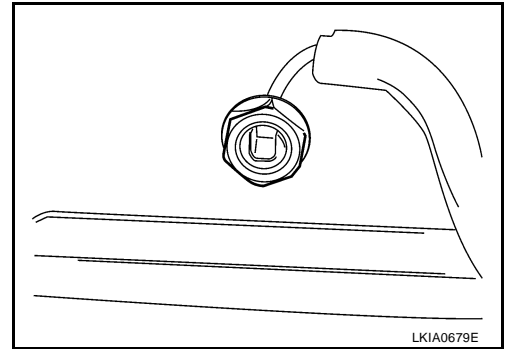

Installation

Installation is in the reverse order of removal.

A
B
C
D
E
F
G
H
I
J
AV
L
M

AUDIO

STEERING WHEEL AUDIO CONTROL SWITCHES

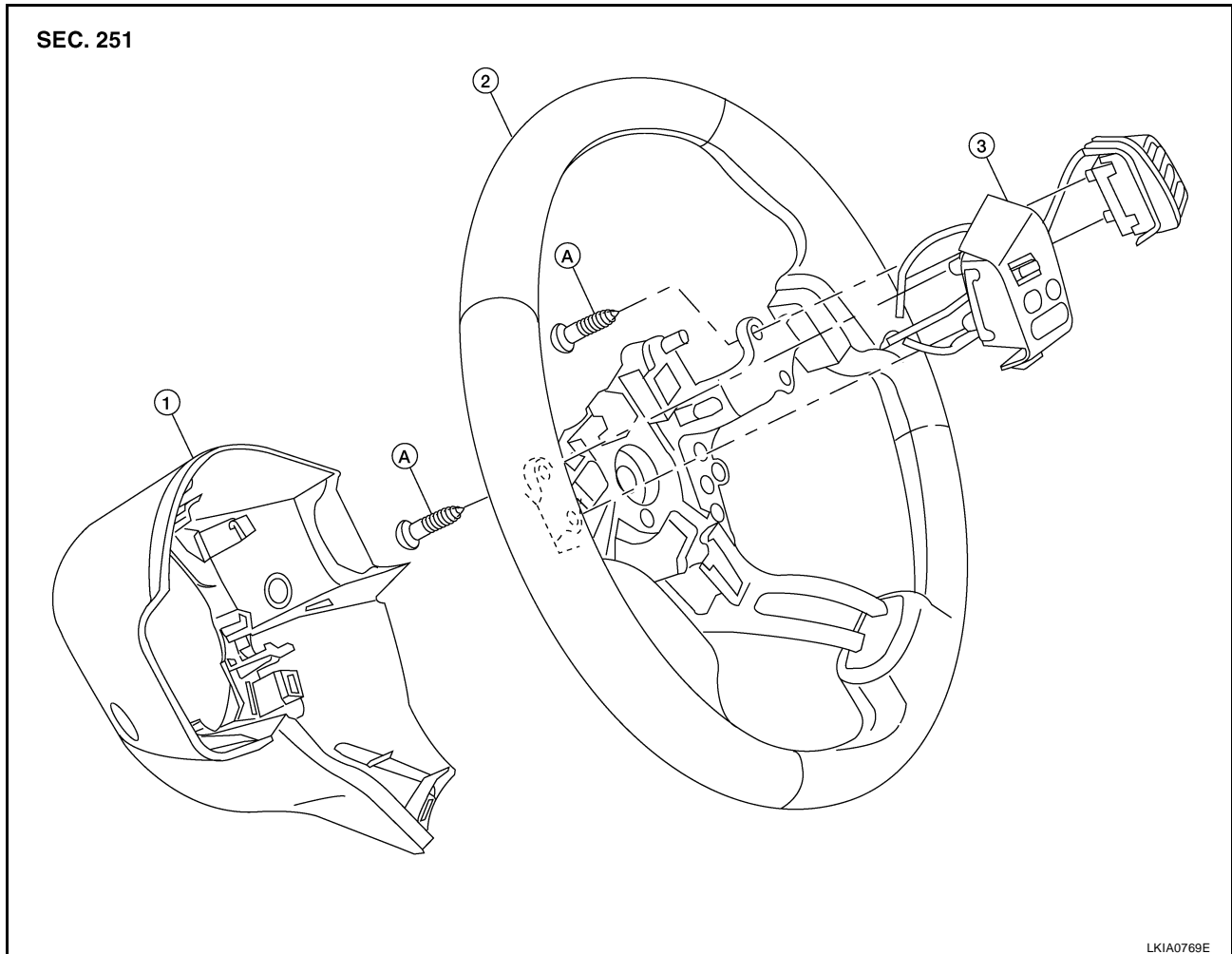

LKIA0769E

1. Steering wheel finisher cover

2. Steering wheel

3. Steering wheel audio control switches

A. Screws

Removal

1. Remove the driver air bag module. Refer to [SRS-41, "DRIVER AIR BAG MODULE"](#) .
2. Remove the steering wheel.
3. Remove the steering wheel finisher cover.
4. Remove the screws and the steering wheel audio control switches.

Installation

Installation is in the reverse order of removal.

AUDIO

SUBWOOFER

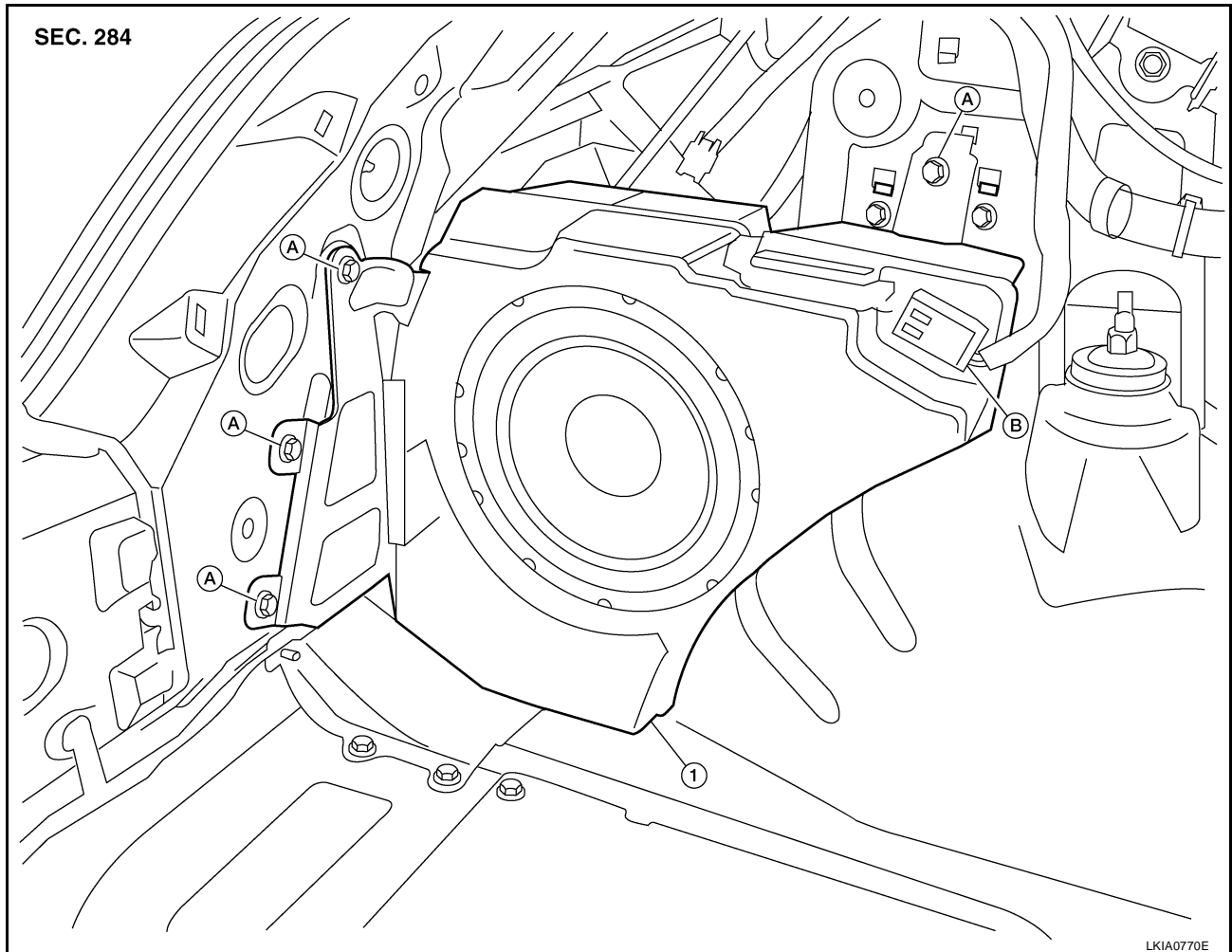

1. Subwoofer

A. Subwoofer bolts

B. Connector

Removal

1. Remove the luggage side lower finisher (LH). Refer to [EI-42, "LUGGAGE FLOOR TRIM"](#).
2. Remove the subwoofer bolts.
3. Disconnect the connector and remove the subwoofer.

Installation

Installation is in the reverse order of removal.

A
B
C
D
E
F
G
H
I
J

AV

L

M

AUDIO ANTENNA

AUDIO ANTENNA

PFP:28200

Location of Antenna

EKS0014K

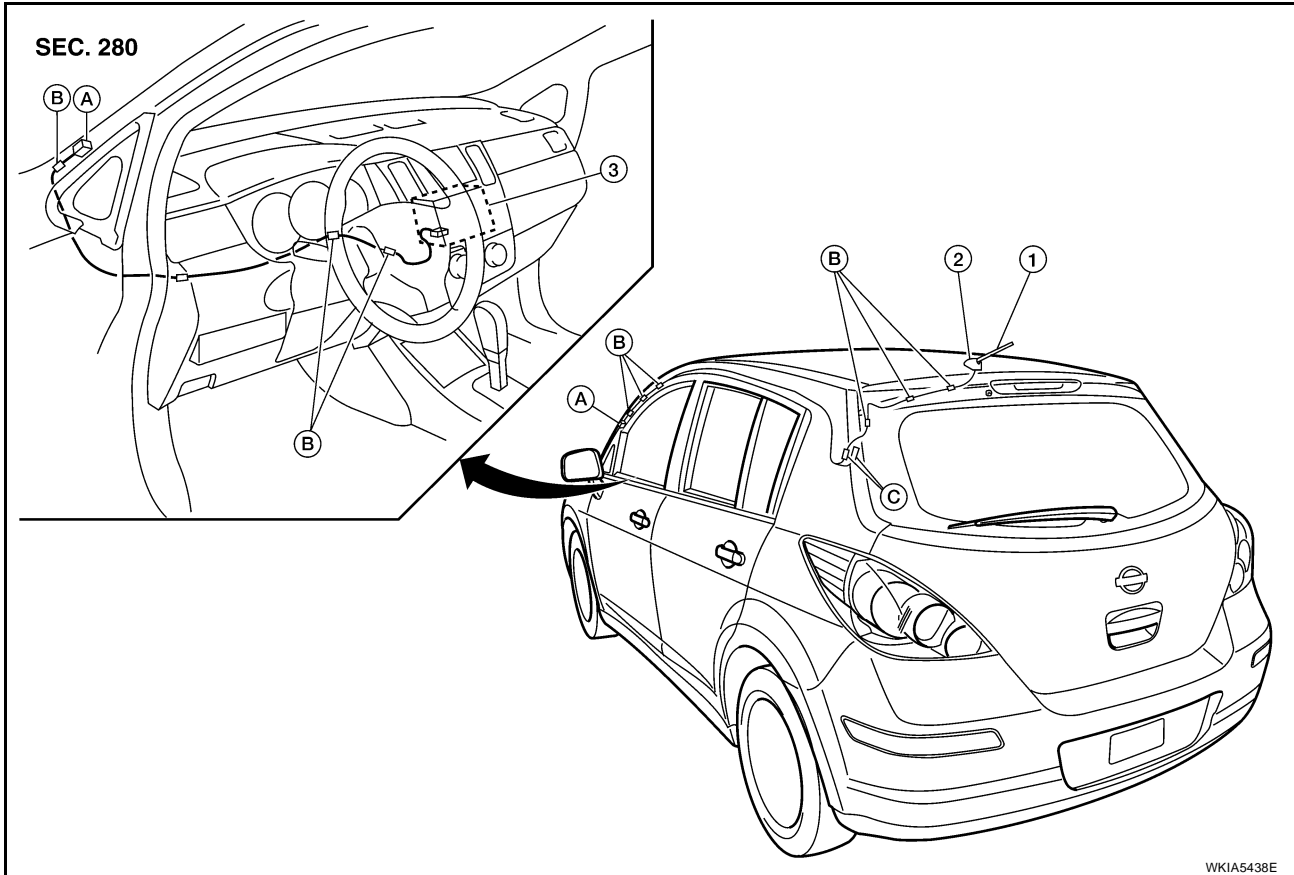

- | | | |
|------------------------------------|----------------------|------------------------------------|
| 1. Roof antenna | 2. Roof antenna base | 3. Audio unit |
| A. Audio antenna harness connector | B. Harness clips | C. Roof antenna harness connectors |

Removal and Installation of Roof Antenna

REMOVAL

EKS0014L

1. Remove the luggage side upper finisher (LH). Refer to [EI-42, "LUGGAGE FLOOR TRIM"](#) .
2. Remove rear assist grip (LH). Refer to [EI-39, "HEADLINING"](#) .
3. Remove three clips of headlining (rear side). Pull down headlining (rear side) and obtain space for work between vehicle and headlining.
4. Disconnect the roof antenna harness connectors.
5. Remove nut (A) and clips (B).
6. Remove the roof antenna.

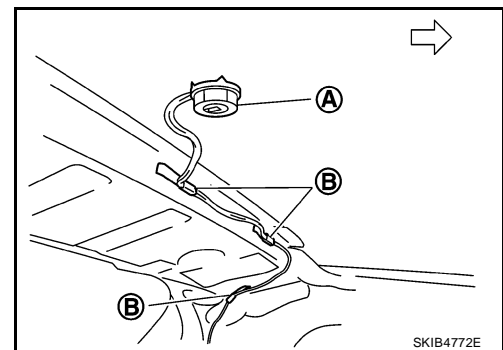

INSTALLATION

Installation is in the reverse order of removal.

TELEPHONE

PFP:28342

Component Parts and Harness Connector Location

EKS0019E

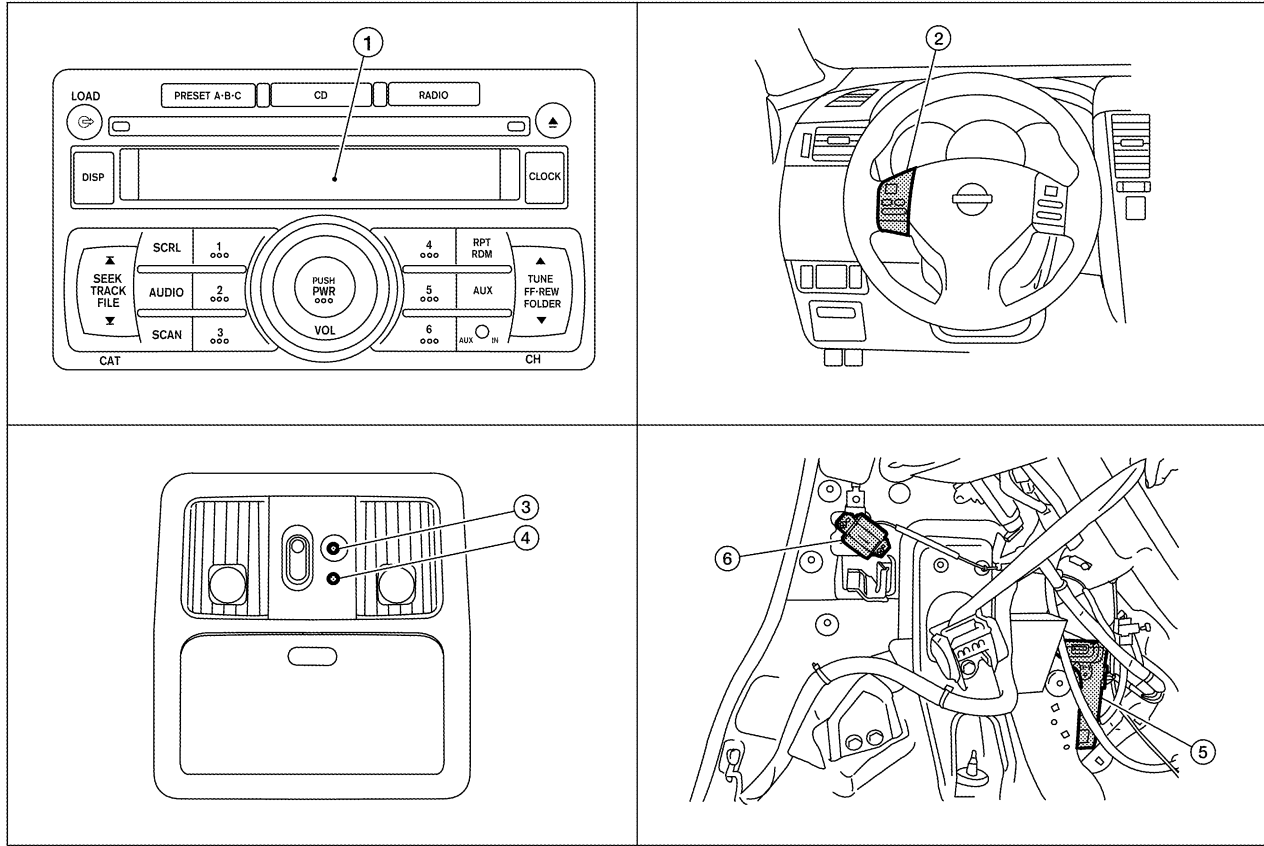

- | | | |
|--------------------------------|---|-----------------------------|
| 1. Audio unit M43, M44 and M45 | 2. Steering wheel audio control switches | 3. Bluetooth microphone R15 |
| 4. Bluetooth ON indicator R15 | 5. Bluetooth control unit B121, B122 [view with luggage side lower finisher (RH) removed] | 6. Bluetooth antenna |

System Description
BLUETOOTH® HANDS-FREE PHONE SYSTEM

EKS0019F

Refer to the Owner's Manual for Bluetooth telephone system operating instructions.

NOTE:

Cellular telephones must have their wireless connection set up (paired) before using the Bluetooth telephone system.

Bluetooth telephone system allows users who have a Bluetooth cellular telephone to make a wireless connection between their cellular telephone and the Bluetooth control unit. Hands-free cellular telephone calls can be sent and received. Personal memos can be created using the NISSAN Voice Recognition system. Some Bluetooth cellular telephones may not be recognized by the Bluetooth control unit. When a cellular telephone or the Bluetooth control unit is replaced, the telephone must be paired with the Bluetooth control unit. Different cellular telephones may have different pairing procedures. Refer to the cellular telephone operating manual.

A
B
C
D
E
F
G
H
I
J
AV

L
M

TELEPHONE

Bluetooth Telephone System Diagram

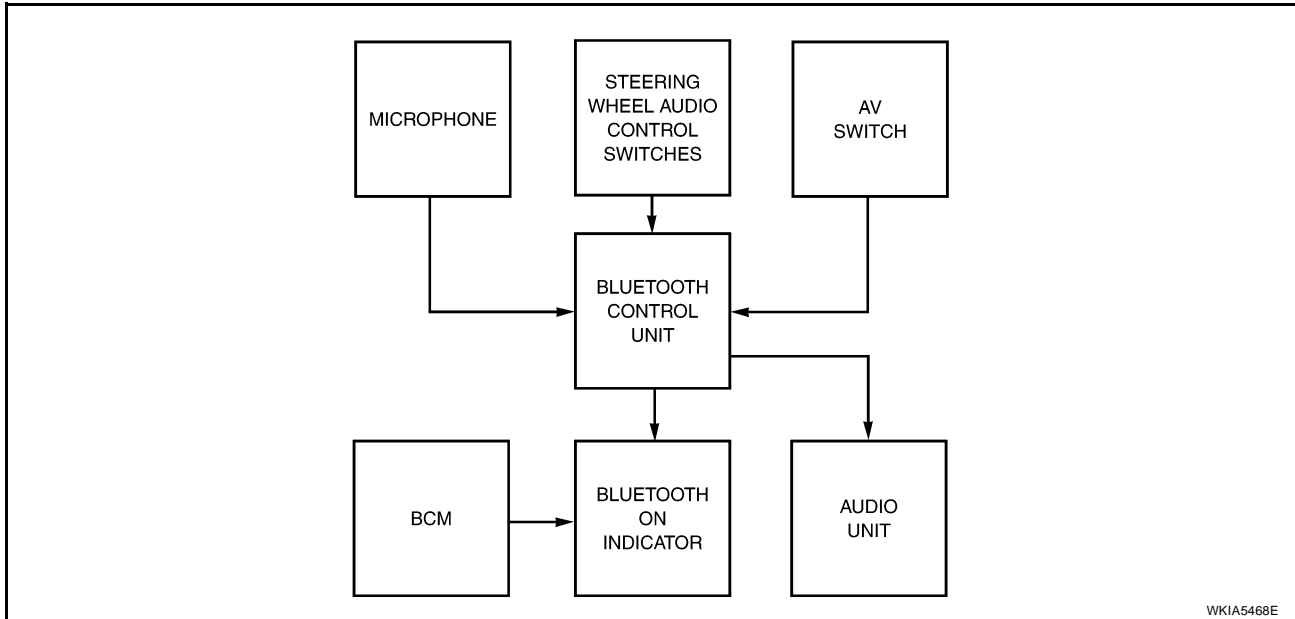

Bluetooth Control Unit

When the ignition switch is turned to ACC or ON, the Bluetooth control unit will power up. During power up, the Bluetooth control unit is initialized and performs various self checks. Initialization may take up to 10 seconds. During this time the Bluetooth ON indicator will flash until initialization is complete. If a phone is present in the vehicle and paired with the Bluetooth control unit, NISSAN Voice Recognition will then become active and the Bluetooth ON indicator will remain on. Bluetooth telephone functions can be turned off using the NISSAN Voice Recognition system.

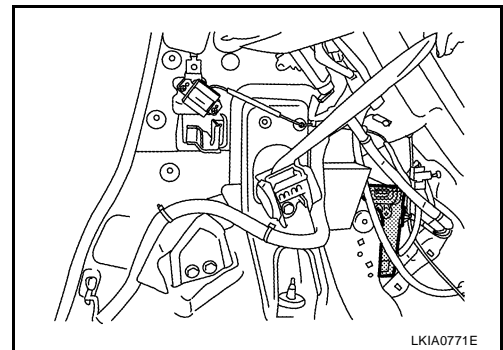

BCM

The BCM supplies power for the Bluetooth ON indicator (view with glove box removed).

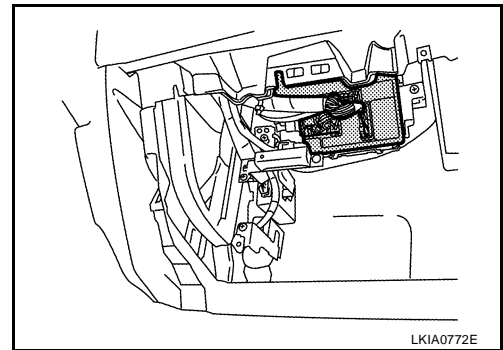

Steering Wheel Audio Control Switches

When buttons on the steering wheel audio control switch are pushed, the resistance in steering wheel audio control switch circuit changes depending on which button is pushed. The Bluetooth control module uses this signal to perform various functions while navigating through the voice recognition system.

The following functions can be performed using the steering wheel audio control switch:

- Initiate Self Diagnosis of the Bluetooth telephone system
- Start a voice recognition session
- Answer and end telephone calls
- Adjust the volume of calls

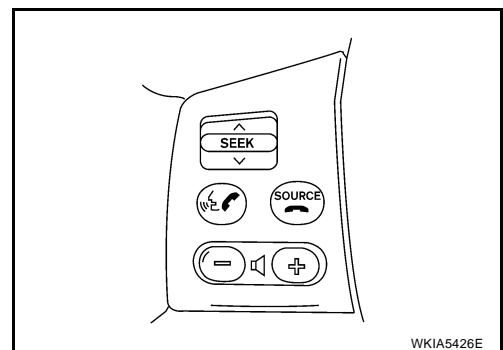

TELEPHONE

- Record memos

Volume Switch

Call volume can be adjusted using the Audio unit volume switch.

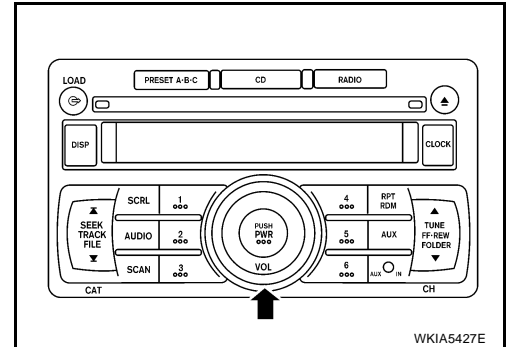

Bluetooth Microphone

The Bluetooth microphone is located in the roof console assembly. The Bluetooth microphone sends a signal to the Bluetooth control unit. The Bluetooth microphone can be actively tested during self-diagnosis.

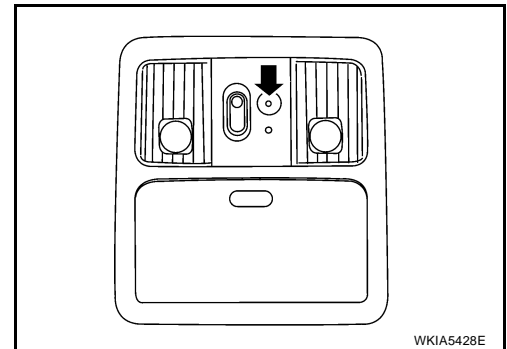

Bluetooth ON Indicator

The Bluetooth ON indicator is located in the overhead console. The indicator will flash during power up while the Bluetooth control unit is initializing. This process may take up to 10 seconds. If a phone is present in the vehicle and paired with the Bluetooth control unit, the indicator will remain on to indicate that the system is ready for voice commands. The indicator flashes during self-diagnosis.

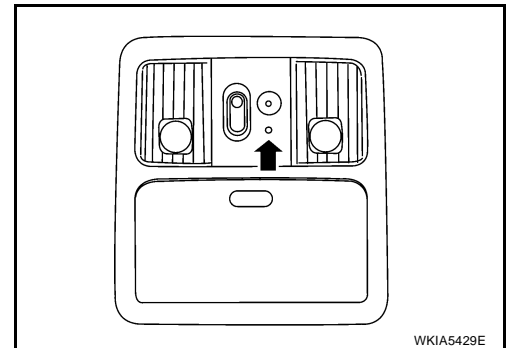

Audio Unit

The audio unit receives signals from the Bluetooth control unit and sends audio signals to the speakers.

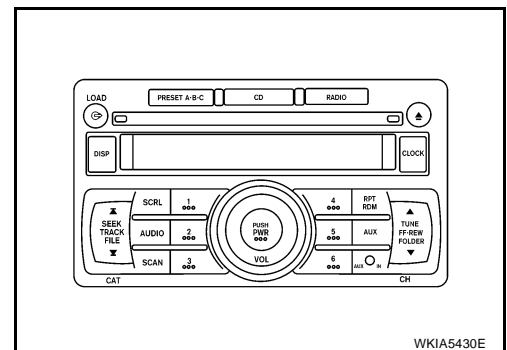

A
B
C
D
E
F
G
H
I
J
AV
L
M

TELEPHONE

Wiring Diagram — H/PHON —

EKS0019G

AV-H/PHON-01

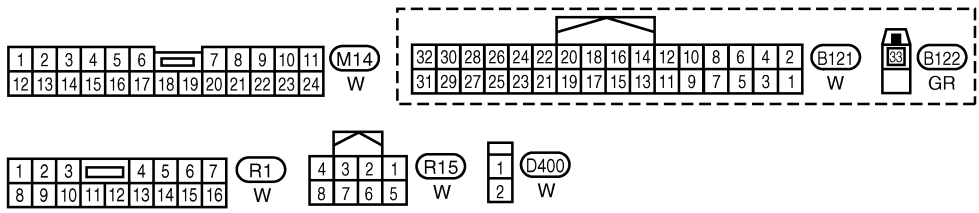
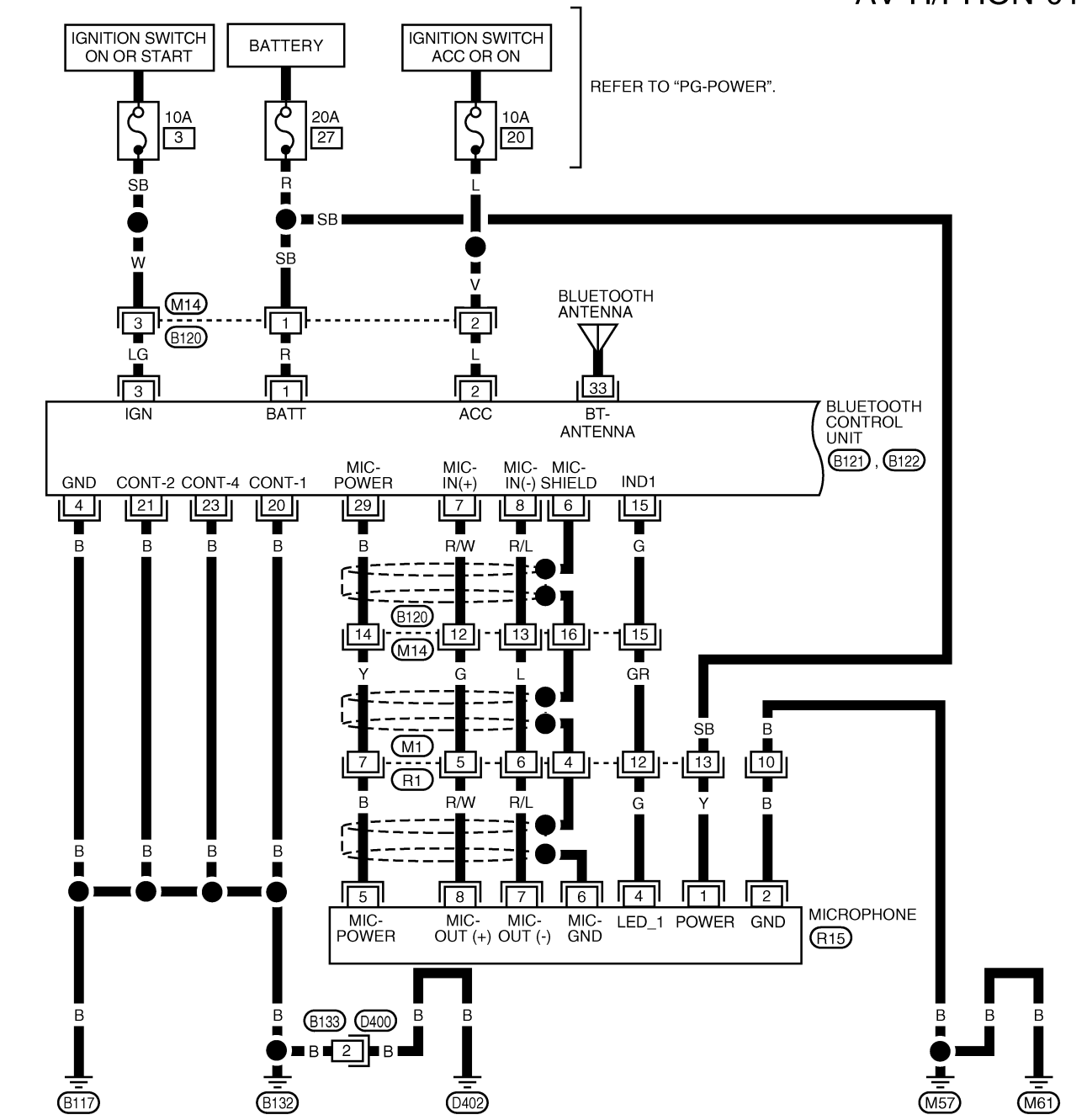

WKWA4987E

TELEPHONE

AV-H/PHON-02

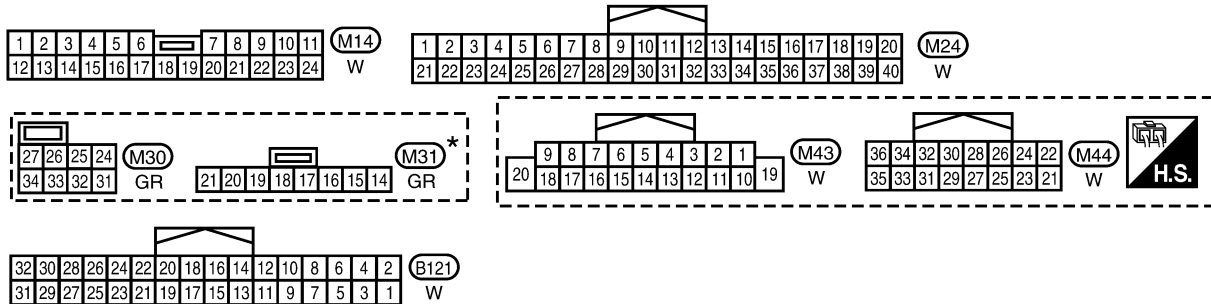
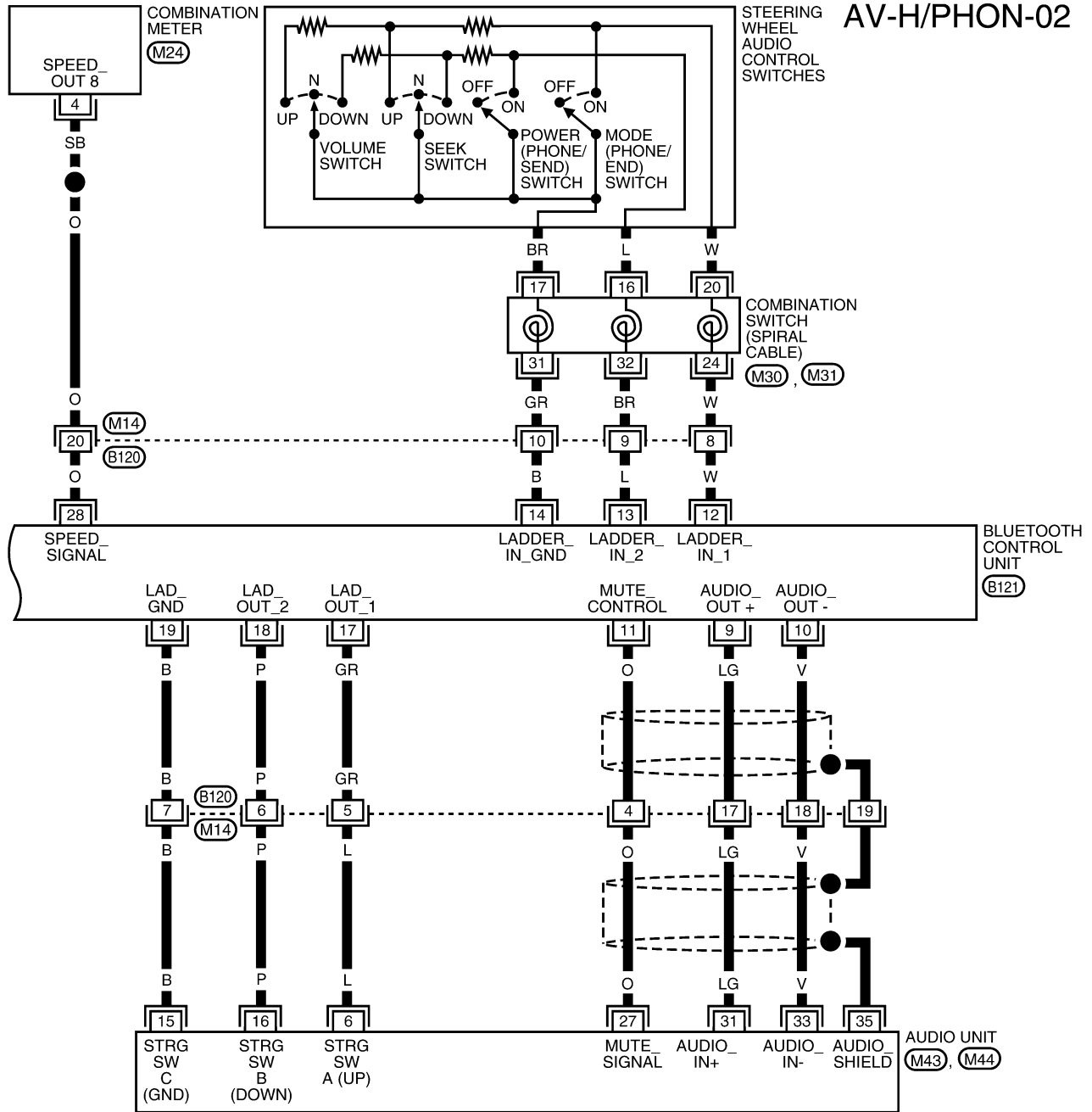

*: THIS CONNECTOR IS NOT SHOWN IN "HARNESS LAYOUT" OF PG SECTION.

WKWA4988E

TELEPHONE

Bluetooth Control Unit Harness Connector Terminal Layout

EKS0019H

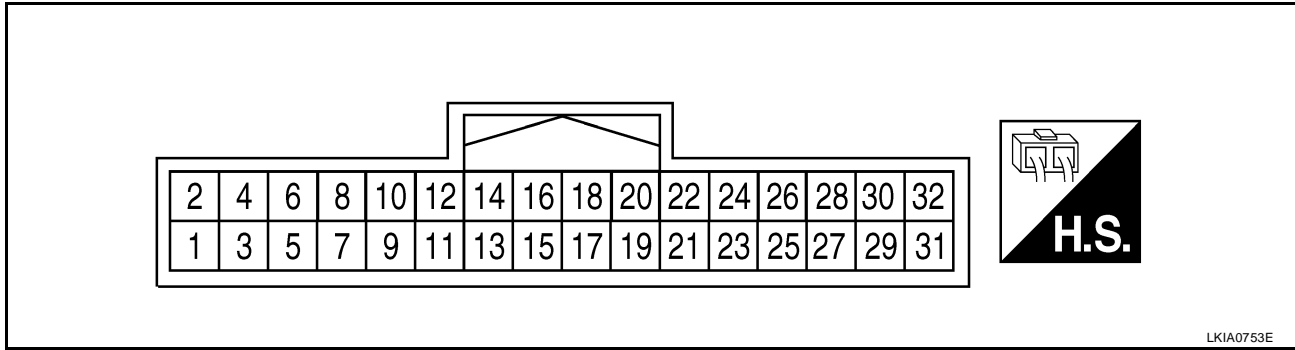

Terminals and Reference Value for Bluetooth Control Unit

EKS0019I

Terminal (Wire color)		Item	Signal input/output	Condition		Reference value (Approx.)	Example of symptom
+	-			Ignition switch	Operation		
1 (R)	Ground	Battery power	Input	-	-	Battery voltage	System does not work properly.
2 (L)	Ground	ACC power	Input	ACC/ON	-	Battery voltage	System does not work properly.
3 (LG)	Ground	IGN power	Input	ON/START	-	Battery voltage	System does not work properly.
4 (B)	-	Ground	-	-	-	-	-
6	-	Shield	-	-	-	-	-
7 (R/W)	8 (R/L)	Mic-in signal	Input	-	-	-	Bluetooth Microphone inoperative.
9 (LG)	10 (V)	Audio out	Output	ACC/ON	Bluetooth control unit sends audio signal	 SKIB3609E	Audio can not be heard.
11(O)	-	Mute	Output	-	-	5V	Mute inoperative.
12 (W)	Ground	Remote control switch 1	Input	ACC/ON	Press MODE switch	0V	Steering wheel audio control switches do not function.
					Press SEEK UP switch	0.75V	
					Press VOL UP switch	2V	
					Except for above	5V	
13 (L)	Ground	Remote control switch 2	Input	ACC/ON	Press POWER switch	0V	Steering wheel audio control switches do not function.
					Press SEEK DOWN switch	0.75V	
					Press VOL DOWN switch	2V	
					Except for above	5V	
14 (B)	-	Remote control ground	Input	-	-	-	Steering wheel audio control switches do not function.

TELEPHONE

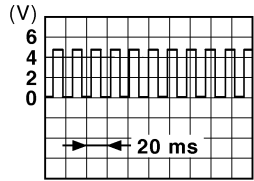
Terminal (Wire color)		Item	Signal input/ output	Condition		Reference value (Approx.)	Example of symptom
+	-			Ignition switch	Operation		
15 (G)	Ground	Bluetooth ON indica- tor LED	Output	-	Bluetooth control unit initialized and paired with phone	Battery voltage	Bluetooth ON indica- tor inoperative.
17 (GR)	Ground	Audio unit switch 1	Output	ACC/ ON	Press Phone/End switch	0V	Steering wheel audio controls do not func- tion.
					Press SEEK UP switch	0.75V	
					Press VOL UP switch	2V	
					Except for above	5V	
18 (P)	Ground	Audio unit switch 2	Output	ACC/ ON	Press Phone/ Send switch	0V	Steering wheel audio controls do not func- tion.
					Press SEEK DOWN switch	0.75V	
					Press VOL DOWN switch	2V	
					Except for above	5V	
19 (B)	Ground	Audio unit switch ground	Output	-	-	-	Steering wheel audio controls do not func- tion.
20 (B)	-	Cont-1	-	-	-	-	-
21 (B)	-	Cont-2	-	-	-	-	-
23 (B)	-	Cont-4	-	-	-	-	-
28 (O)	Ground	Vehicle speed sig- nal (8- pulse)	Input	ON	When vehicle speed is approx. 40 km/h (25 MPH)	 <p style="text-align: right; font-size: small;">PKIC0643E</p>	Speed sensitive vol- ume is inoperative.
29 (B)	Ground	Bluetooth Microphone power	Output	-	-	5V	Bluetooth Micro- phone inoperative.
33	-	Bluetooth antenna sig- nal	Input	-	-	-	-

A
B
C
D
E
F
G
H
I
J
L
M

AV

Bluetooth Control Unit Self-Diagnosis Function

The Bluetooth control unit has two diagnostic checks. The first diagnostic check is performed automatically every ignition cycle during control unit initialization. The second diagnostic check is performed by the technician using the steering wheel audio control switches prior to trouble diagnosis.

BLUETOOTH CONTROL UNIT INITIALIZATION CHECKS

- Internal control unit failure
- Bluetooth antenna connection open or shorted
- Steering wheel audio control switches (SEND/END) stuck closed
- Vehicle speed pulse count
- Bluetooth Microphone connection test (with playback to operator)
- Bluetooth inquiry check

SELF-DIAGNOSIS MODE

1. Turn ignition switch to ACC or ON.
2. Wait for the Bluetooth system to complete initialization and the Bluetooth ON indicator to stop flashing. This may take up to 10 seconds.
3. Press and hold the steering wheel audio control switch SEND button for at least 5 seconds. The Bluetooth system will begin to play a verbal prompt.

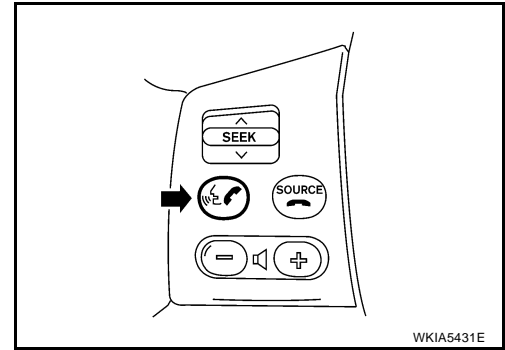

4. While the prompt is playing, momentarily press both the steering wheel audio control switches SEND and END buttons simultaneously. The Bluetooth system will sound a 5 second beep.
5. While the beep is sounding, momentarily press both the steering wheel audio control switches SEND and END buttons simultaneously again.
6. The Bluetooth system has now entered into the diagnostic mode. Results of the diagnostic checks will be verbalized to the technician and the Bluetooth ON indicator will flash. Refer to [AV-57, "Workflow"](#).
7. If there are no failure records to report, the speed pulse count will be reported next.
8. After the speed pulse count is reported, an interactive Bluetooth microphone test will be performed. Follow the voice prompt. If the Bluetooth microphone test fails refer to [AV-57, "Workflow"](#).
9. Self-diagnosis mode is complete when the voice prompt says "All diagnostic functions completed". A short beep is heard.

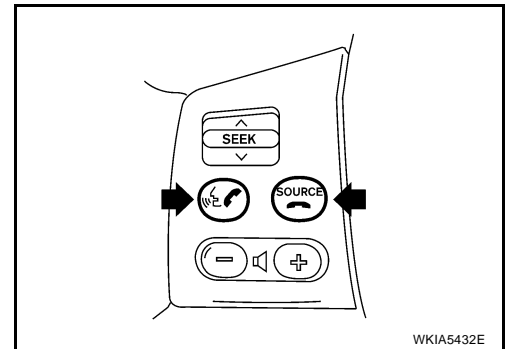

TELEPHONE

Workflow

EKS0019K

Flashing Pattern (Bluetooth ON indicator)	Failure Message	Action
1	"Internal failure"	Replace Bluetooth control unit. Refer to AV-63, "BLUETOOTH CONTROL UNIT" .
2	"Bluetooth antenna open"	1. Inspect harness connection.
3	"Bluetooth antenna shorted"	2. Replace Bluetooth antenna. Refer to AV-63, "BLUETOOTH CONTROL UNIT" .
4	"Phone/Send for the Hands Free Phone System is stuck"	Check steering wheel audio control switches. Refer to AV-30, "Steering Switch Check (With Bluetooth)" .
5	"Phone/End for the Hands Free Phone System is stuck"	
-	"Bluetooth Microphone test" (failed interactive test)	1. Inspect harness between Bluetooth control unit and Bluetooth microphone. 2. Replace Bluetooth microphone. Refer to AV-65, "BLUETOOTH MICROPHONE" .

Power Supply and Ground Circuit Check for Bluetooth Control Unit

EKS0019L

1. CHECK FUSES

Make sure the following fuses for the Bluetooth control unit are not blown.

Connector	Terminals		Ignition Switch	Fuse No.
	Terminal			
B121	1		All positions	27
	2		ACC/ON	20
	3		ON/START	3

OK or NG

OK >> GO TO 2.

NG >> If fuse is blown, be sure to eliminate cause of malfunction before installing new fuse. Refer to [PG-4, "POWER SUPPLY ROUTING CIRCUIT"](#).

2. CHECK POWER SUPPLY CIRCUIT

- Disconnect Bluetooth control unit connector B121.
- Check voltage between connector terminals and ground as follows.

Terminals		(-)	Ignition switch position		
(+)	Terminal		OFF	ACC	ON
B121	1	Ground	Battery voltage	Battery voltage	Battery voltage
	2		0V	Battery voltage	Battery voltage
	3		0V	0V	Battery voltage

OK or NG

OK >> GO TO 3.

NG >> Check harness for open between Bluetooth control unit and fuse.

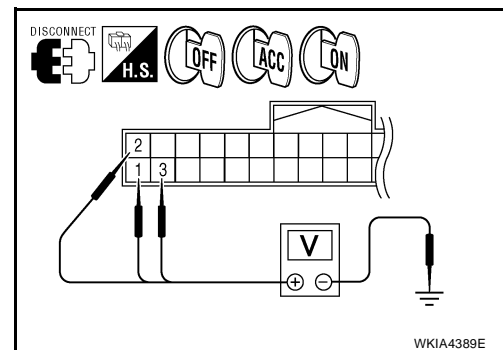

WKIA4389E

TELEPHONE

3. CHECK GROUND CIRCUITS

1. Turn ignition switch OFF.
2. Check continuity between the following Bluetooth control unit terminals and ground.

Terminals			Continuity
Connector	Terminal	—	
B121	4	Ground	Yes
	20		
	21		
	23		

OK or NG

- OK >> Inspection End.
NG >> Repair or replace harness.

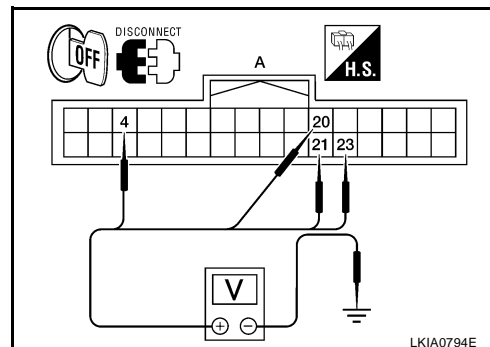

Basic Inspection of Hands-Free Phone

EKS001B8

1. CHECK INDICATOR OPERATION

1. Turn ignition switch ACC.
2. Check that the indicator is blinking.

OK or NG

- OK >> GO TO 2
NG >> GO TO 3

2. CHECK STEERING WHEEL AUDIO CONTROL SWITCH OPERATION

1. Press the SEND switch.
2. Check the indicator is blinking.

OK or NG

- OK >> INSPECTION END
NG >> Check steering wheel audio control switch circuit.

3. CHECK BLUETOOTH INDICATOR OUTPUT VOLTAGE

1. Disconnect Bluetooth microphone connector.
2. Check voltage between Bluetooth microphone connector R15 terminal 4 and ground.

4 - Ground : Approx. 12 V

OK or NO

- OK >> Replace Bluetooth indicator. Refer to [AV-65, "BLUE-TOOTH MICROPHONE"](#) .
NG >> GO TO 4.

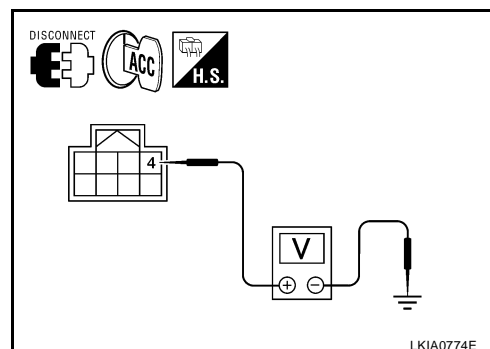

TELEPHONE

4. CHECK BLUETOOTH INDICATOR CIRCUIT

1. Turn ignition switch OFF.
2. Disconnect Bluetooth control unit connector B121 and Bluetooth microphone connector R15.
3. Check continuity between Bluetooth control unit connector B121 (A) terminal 15 and Bluetooth microphone connector R15 (B) terminal 4.

15 - 4 : Continuity should exist

OK or NO

- OK >> Replace Bluetooth control unit. Refer to [AV-63, "BLUETOOTH CONTROL UNIT"](#).
- NG >> Repair or replace harness.

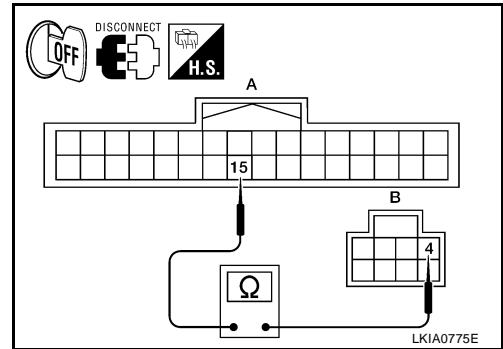

Steering Wheel Audio Control Switch Does Not Operate

EKS001B9

1. CHECK STEERING WHEEL AUDIO CONTROL SWITCH RESISTANCE

1. Turn ignition switch OFF.
2. Disconnect steering wheel audio control switch connector.
3. Check steering wheel audio control switch. Refer to [AV-30, "Steering Switch Check \(With Bluetooth\)"](#).

OK or NG

- OK >> GO TO 2.
- NG >> Replace steering wheel audio control switch. [AV-46, "STEERING WHEEL AUDIO CONTROL SWITCHES"](#).

2. CHECK AUDIO UNIT

1. Turn ignition switch ON.
2. Check voltage between audio unit harness connector M43 terminals 6, 16 and ground.

6 - Ground : Approx. 5 V

16 - Ground : Approx. 5 V

OK or NG

- OK >> Replace audio unit. Refer to [AV-43, "AUDIO UNIT"](#).
- NG >> GO TO 5.

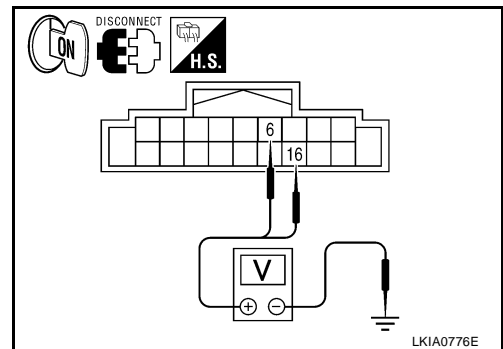

3. CHECK BLUETOOTH CONTROL UNIT

1. Turn ignition switch ON.
2. Check voltage between Bluetooth control unit harness connector B121 terminals 17, 18 and ground.

17 - Ground : Approx. 5 V

18 - Ground : Approx. 5 V

OK or NG

- OK >> Repair or replace harness.
- NG >> Replace Bluetooth control unit. [AV-63, "BLUETOOTH CONTROL UNIT"](#).

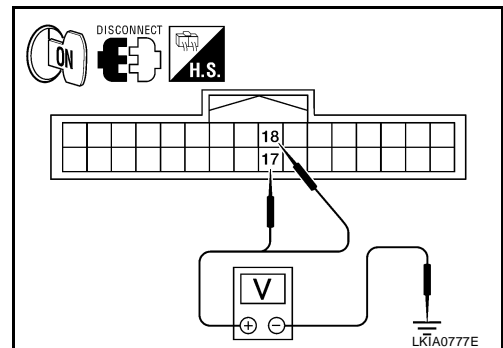

TELEPHONE

EKS001BA

Voice Activated Control Function Does Not Operate

NOTE:

Even under the normal condition, Bluetooth voice guidance may not occur when pressing steering wheel audio control switch.

BLUETOOTH VOICE GUIDANCE IS HEARD WHEN PRESSING STEERING WHEEL AUDIO CONTROL SWITCH

1. CHECK HARNESS BETWEEN BLUETOOTH CONTROL UNIT AND BLUETOOTH MICROPHONE

1. Turn ignition switch OFF.
2. Disconnect Bluetooth control unit connector and Bluetooth microphone connector.
3. Check continuity between Bluetooth control unit connector B121 (A) and Bluetooth microphone connector R15 (B).

Terminals				Continuity
Connector	Terminal	Connector	Terminal	
A: B121	6	B: R15	6	Yes
	7		8	
	8		7	
	29		5	

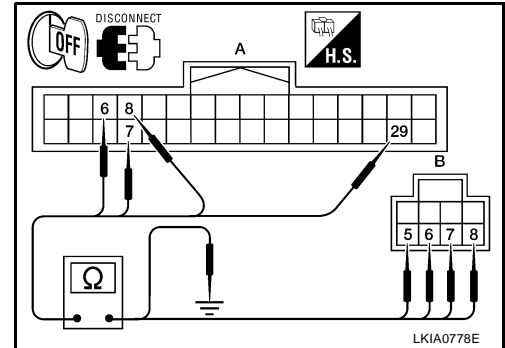

4. Check continuity between Bluetooth control unit harness connector B121 and ground.

Terminals			Continuity
Connector	Terminal	—	
A: B121	7	Ground	No
	8		
	29		

OK or NG

OK >> GO TO 2.

NG >> Repair harness or connector.

2. CHECK BLUETOOTH MICROPHONE POWER SUPPLY

1. Connect Bluetooth control unit connector and Bluetooth microphone connector.
2. Turn ignition switch ON.
3. Check voltage between Bluetooth microphone connector R15 terminal 5 and ground.

5 - Ground : Approx. 5 V

YES or NO

YES >> GO TO 3.

NO >> Replace Bluetooth control unit. Refer to [AV-63, "BLUETOOTH CONTROL UNIT"](#).

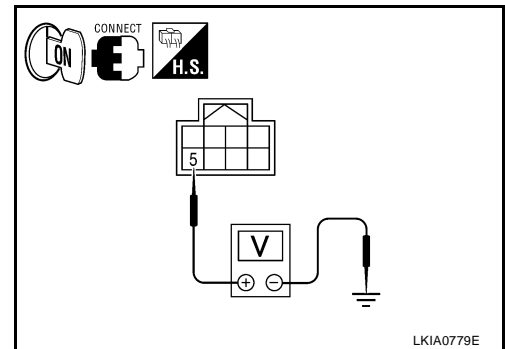

TELEPHONE

3. CHECK MIC. SIGNAL

1. Check signal between Bluetooth control unit harness connector B121 terminals 7 and 8.

When giving a voice

7 – 8:

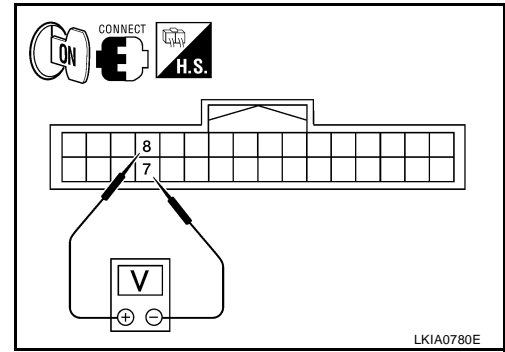
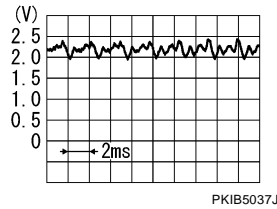

OK or NG

- OK >> Replace Bluetooth control unit. Refer to [AV-63, "BLUETOOTH CONTROL UNIT"](#).
- NG >> Replace Bluetooth microphone. Refer to [AV-65, "BLUETOOTH MICROPHONE"](#).

BLUETOOTH VOICE GUIDANCE IS NOT HEARD WHEN PRESSING STEERING WHEEL AUDIO CONTROL SWITCH

1. CHECK STEERING WHEEL AUDIO CONTROL SWITCH CIRCUIT

Refer to [AV-30, "Steering Switch Check \(With Bluetooth\)"](#).

OK or NG

- OK >> GO TO 2.
- NG >> Replace applicable parts.

2. CHECK BLUETOOTH VOICE SIGNAL CIRCUIT

1. Turn ignition switch OFF.
2. Disconnect Bluetooth control unit connector and audio unit connector.
3. Check continuity between Bluetooth control unit harness connector B121 (A) and audio unit harness connector M44 (B).

Terminals				Continuity
Connector	Terminal	Connector	Terminal	
A: B121	9	B: M44	31	Yes
	10		33	
	11		27	

4. Check continuity between Bluetooth control unit harness connector B121 (A) and ground.

Terminals			Continuity
Connector	Terminal	—	
A: B121	9	Ground	No
	10		
	11		

OK or NG

- OK >> GO TO 3.
- NG >> Repair harness or connector.

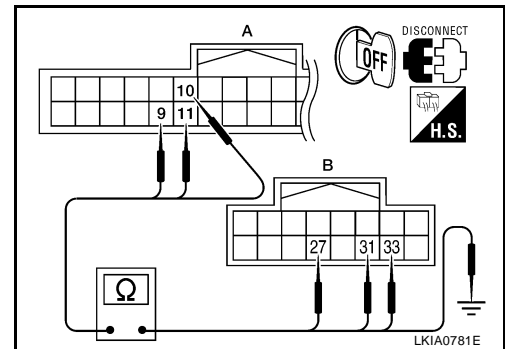

TELEPHONE

3. CHECK MUTE SIGNAL

1. Connect Bluetooth control unit connector and audio unit connector.
2. Turn ignition switch ON.
3. Check voltage between Bluetooth control unit connector B121 terminal 11 and ground.

11 - Ground : Approx. 5 V

OK or NG

OK >> GO TO 4.

NG >> Replace audio unit. Refer to [AV-43, "AUDIO UNIT"](#) .

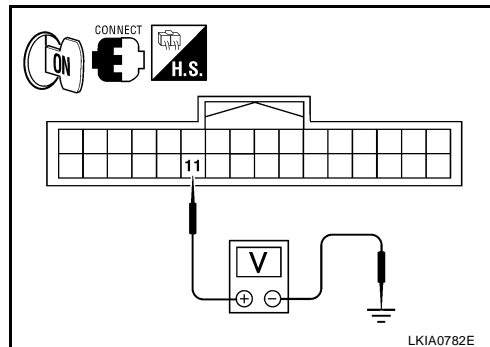

4. CHECK BLUETOOTH VOICE SIGNAL

1. Check signal between Bluetooth control unit harness connector B121 terminals 9 and 10.

When giving a voice

9 – 10:

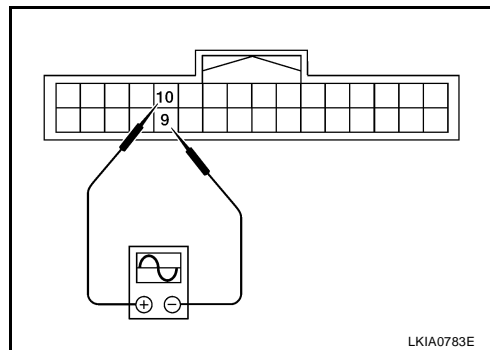
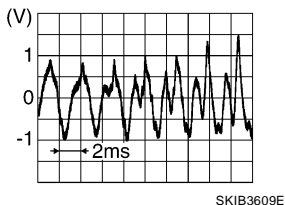

OK or NG

OK >> Replace audio unit. Refer to [AV-43, "AUDIO UNIT"](#) .

NG >> Replace Bluetooth control unit. Refer to [AV-63, "BLUETOOTH CONTROL UNIT"](#) .

TELEPHONE

Removal and Installation BLUETOOTH CONTROL UNIT

EKS0019M

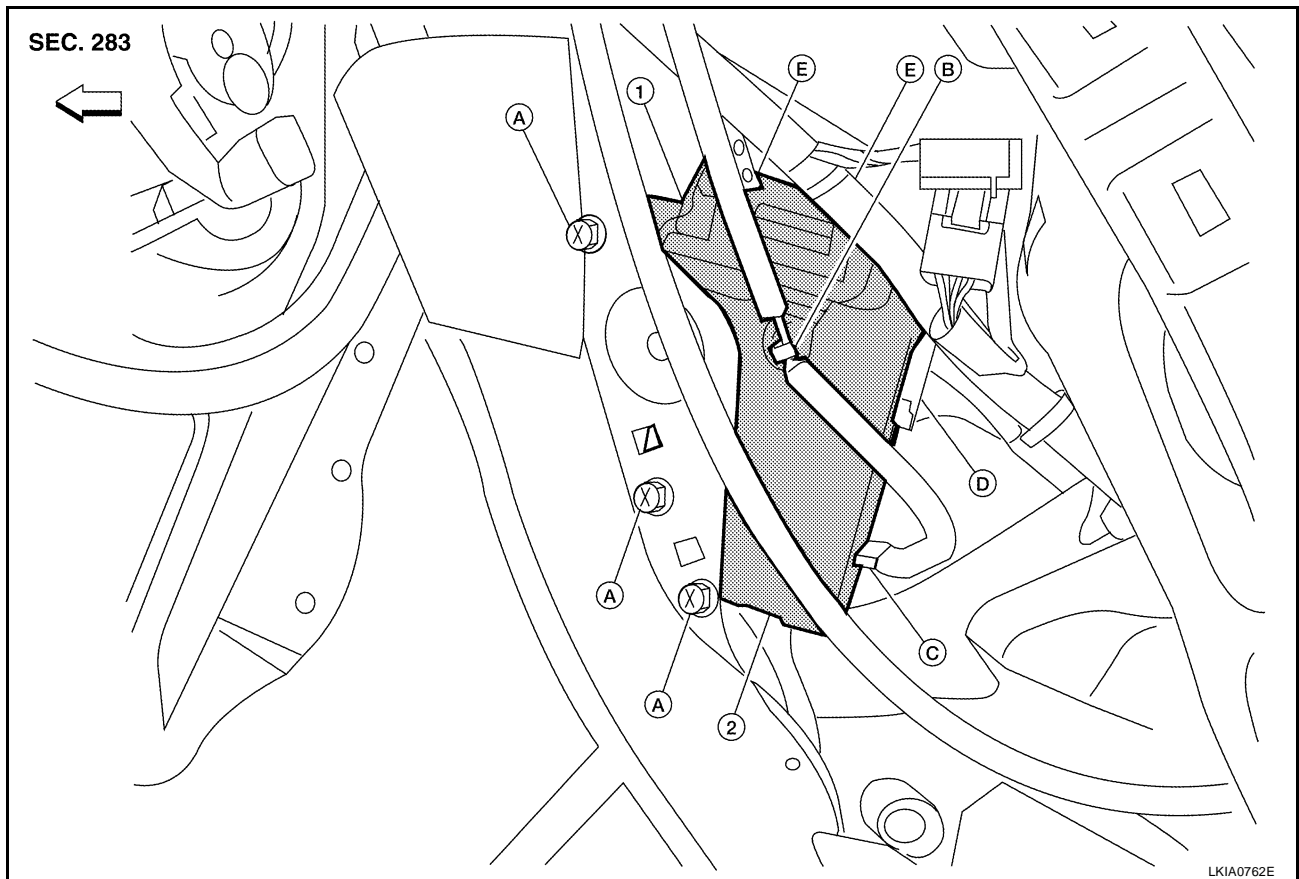

- | | | |
|-----------------------------------|--|-------------------------------------|
| 1. Bluetooth control unit bracket | 2. Bluetooth control unit | A. Bolt |
| B. Harness clip | C. Bluetooth antenna harness connector | D. Bluetooth control unit connector |
| E. screw | ← Front | |

Removal

1. Remove luggage side lower finish (RH). Refer to [EI-42, "Removal and Installation"](#).
2. Disconnect Bluetooth antenna harness clip.
3. Disconnect Bluetooth antenna harness connector.
4. Disconnect Bluetooth control unit harness connector.
5. Remove Bluetooth control unit upper and lower bracket bolts.
6. Unhook the Bluetooth control unit upper and lower brackets and remove Bluetooth control unit.
7. Remove Bluetooth control unit bracket screws and remove the upper and lower brackets from unit.

Installation

Installation is in the reverse order of removal.

A
B
C
D
E
F
G
H
I
J

AV

L
M

TELEPHONE

BLUETOOTH ANTENNA

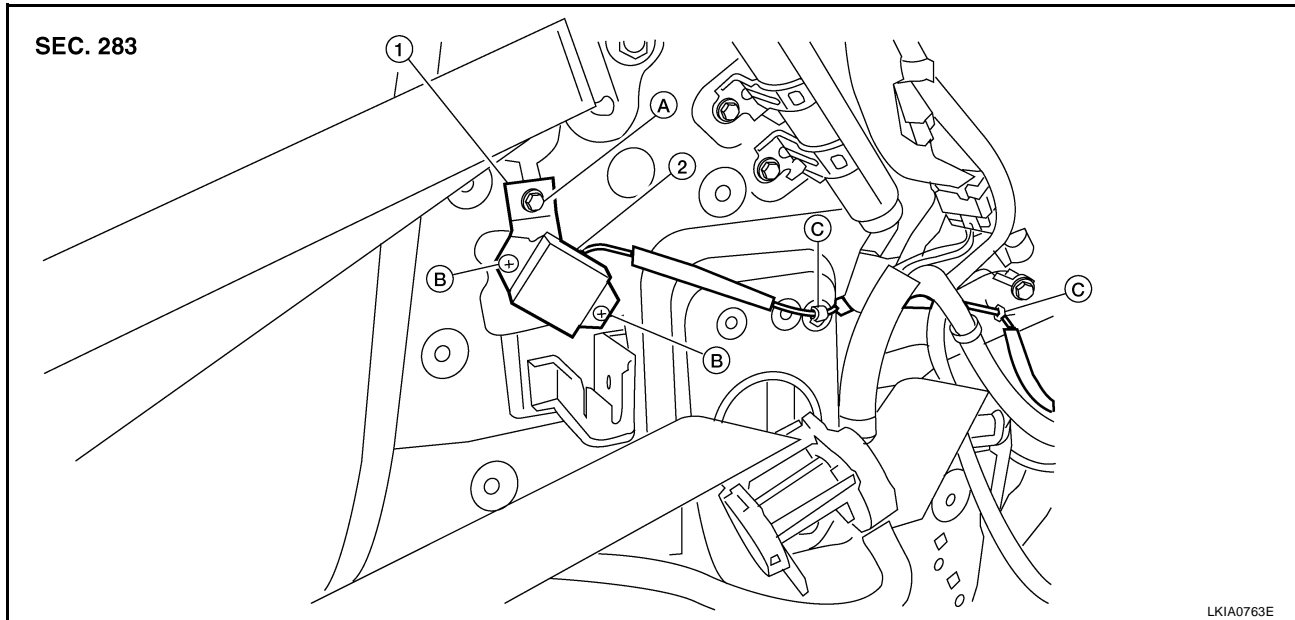

- | | | |
|------------------------------|----------------------|---------|
| 1. Bluetooth antenna bracket | 2. Bluetooth antenna | A. Bolt |
| B. Screws | C. Harness clips | |

Removal

1. Remove luggage side lower finisher (RH). Refer to [EI-42, "Removal and Installation"](#) .
2. Disconnect the Bluetooth harness clips.
3. Disconnect the Bluetooth antenna connector.
4. Remove the Bluetooth antenna bolt and remove antenna.
5. Remove screws and remove bracket.

Installation

Installation is in the reverse order of removal.

TELEPHONE

BLUETOOTH MICROPHONE

Removal

1. Remove over-head console assembly, roof finisher. Refer to [EI-39, "HEADLINING"](#) .
2. Remove the Bluetooth microphone.

Installation

Installation is in the reverse order of removal.

A

B

C

D

E

F

G

H

I

J

AV

L

M

TELEPHONE
