

SECTION **PWO**  
POWER OUTLET

A  
B  
C  
D  
E  
F  
G  
H  
I  
J  
K  
L  
N  
O  
P

CONTENTS

<b>PRECAUTION</b> .....	2	Wiring Diagram .....	3
<b>POWER SOCKET</b> .....	2	<b>ON-VEHICLE REPAIR</b> .....	6
Precaution for Supplemental Restraint System (SRS) "AIR BAG" and "SEAT BELT PRE-TENSIONER" .....	2	<b>POWER SOCKET</b> .....	6
<b>COMPONENT DIAGNOSIS</b> .....	3	Front Power Socket RH (For Cigarette Lighter), Console Power Socket, Front Power Socket (Center Arm Rest) .....	6
<b>POWER SOCKET</b> .....	3	Front Power Socket LH, Rear Power Socket (Cargo Bed) .....	6

PWO

## POWER SOCKET

< PRECAUTION >

### PRECAUTION

#### POWER SOCKET

#### Precaution for Supplemental Restraint System (SRS) "AIR BAG" and "SEAT BELT PRE-TENSIONER"

INFOID:000000001505549

The Supplemental Restraint System such as "AIR BAG" and "SEAT BELT PRE-TENSIONER", used along with a front seat belt, helps to reduce the risk or severity of injury to the driver and front passenger for certain types of collision. This system includes seat belt switch inputs and dual stage front air bag modules. The SRS system uses the seat belt switches to determine the front air bag deployment, and may only deploy one front air bag, depending on the severity of a collision and whether the front occupants are belted or unbelted. Information necessary to service the system safely is included in the SR and SB section of this Service Manual.

**WARNING:**

- To avoid rendering the SRS inoperative, which could increase the risk of personal injury or death in the event of a collision which would result in air bag inflation, all maintenance must be performed by an authorized NISSAN/INFINITI dealer.
- Improper maintenance, including incorrect removal and installation of the SRS, can lead to personal injury caused by unintentional activation of the system. For removal of Spiral Cable and Air Bag Module, see the SR section.
- Do not use electrical test equipment on any circuit related to the SRS unless instructed to in this Service Manual. SRS wiring harnesses can be identified by yellow and/or orange harnesses or harness connectors.

# POWER SOCKET

< COMPONENT DIAGNOSIS >

## COMPONENT DIAGNOSIS

### POWER SOCKET

#### Wiring Diagram

INFOID:000000001663767

POWER SOCKET

CF : WITH FRONT CENTER CONSOLE  
FB : WITH FRONT BENCH SEAT

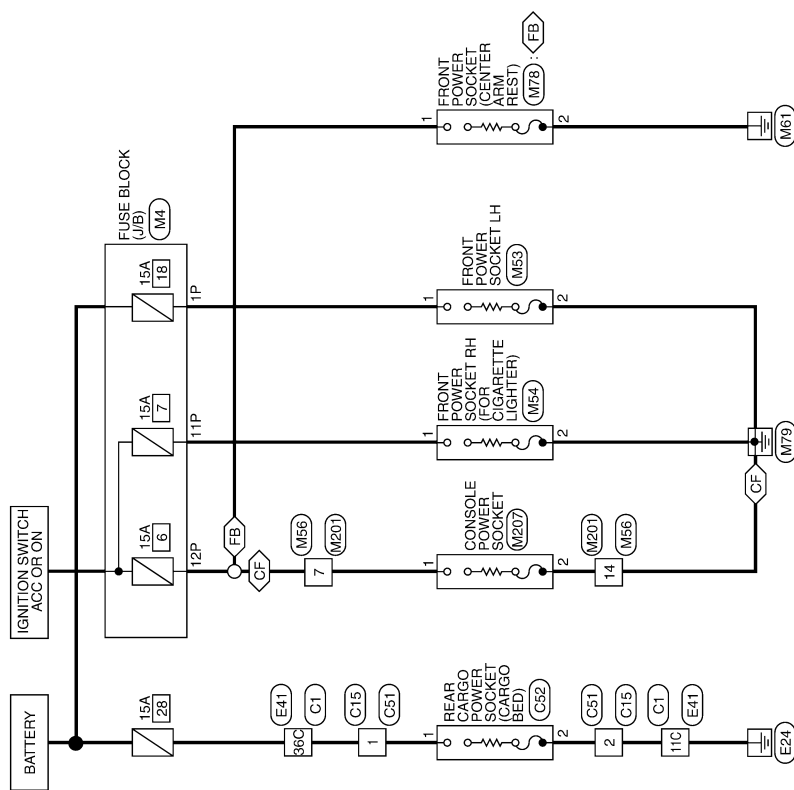

A  
B  
C  
D  
E  
F  
G  
H  
I  
J  
K  
L  
PWO  
N  
O  
P

# POWER SOCKET

## < COMPONENT DIAGNOSIS >

### POWER SOCKET CONNECTORS

Connector No.	M4
Connector Name	FUSE BLOCK (J/B)
Connector Color	WHITE



Terminal No.	Color of Wire	Signal Name
1P	G	-
11P	G/W	-
12P	L/W	-

Connector No.	M53
Connector Name	FRONT POWER SOCKET LH
Connector Color	BLACK



Terminal No.	Color of Wire	Signal Name
1	G	-
2	B	-

Connector No.	M54
Connector Name	FRONT POWER SOCKET RH (FOR CIGARETTE LIGHTER)
Connector Color	BLACK



Terminal No.	Color of Wire	Signal Name
1	G/W	-
2	B	-

Connector No.	M56
Connector Name	WIRE TO WIRE
Connector Color	WHITE

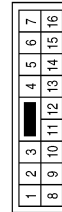

Terminal No.	Color of Wire	Signal Name
7	L/W	-
14	B	-

Connector No.	M78
Connector Name	FRONT POWER SOCKET (CENTER ARM REST)
Connector Color	WHITE



Terminal No.	Color of Wire	Signal Name
1	L/W	-
2	B	-

Connector No.	M201
Connector Name	WIRE TO WIRE
Connector Color	WHITE

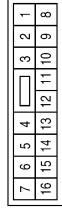

Terminal No.	Color of Wire	Signal Name
7	L/W	-
14	B	-

# POWER SOCKET

< COMPONENT DIAGNOSIS >

Connector No.	M207
Connector Name	CONSOLE POWER SOCKET
Connector Color	BLACK



Terminal No.	Color of Wire	Signal Name
1	L/W	-
2	B	-

Connector No.	E41
Connector Name	WIRE TO WIRE
Connector Color	GRAY

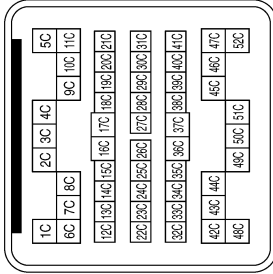

Terminal No.	Color of Wire	Signal Name
11C	B	-
36C	Y	-

Connector No.	C1
Connector Name	WIRE TO WIRE
Connector Color	GRAY

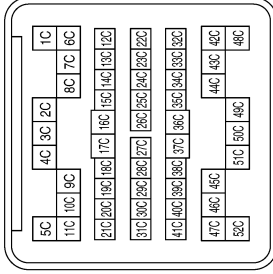

Terminal No.	Color of Wire	Signal Name
11C	B	-
36C	Y	-

Connector No.	C15
Connector Name	WIRE TO WIRE
Connector Color	BROWN



Terminal No.	Color of Wire	Signal Name
1	Y	-
2	B	-

Connector No.	C51
Connector Name	WIRE TO WIRE
Connector Color	WHITE

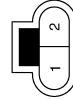

Terminal No.	Color of Wire	Signal Name
1	Y	-
2	B	-

Connector No.	C52
Connector Name	REAR CARGO POWER SOCKET (CARGO BED)
Connector Color	BROWN



Terminal No.	Color of Wire	Signal Name
1	Y	-
2	B	-

ALMIA0284GB

# POWER SOCKET

< ON-VEHICLE REPAIR >

## ON-VEHICLE REPAIR

### POWER SOCKET

Front Power Socket RH (For Cigarette Lighter), Console Power Socket, Front Power Socket (Center Arm Rest)

INFOID:000000001505551

#### REMOVAL AND INSTALLATION

##### Removal

1. Remove inner socket (1) from the ring (2) while pressing the hook (B) on the ring out from square hole (A).
2. Disconnect power socket connector.
3. Remove ring from power socket finisher while pressing pawls.

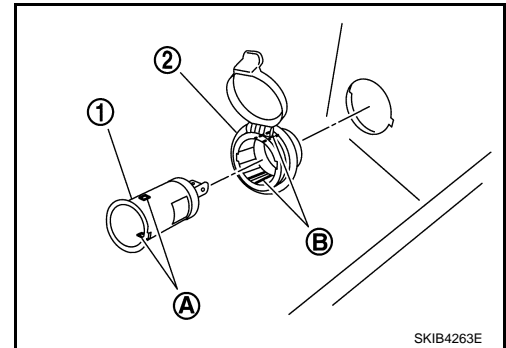

##### Installation

Installation is in the reverse order of removal.

##### **CAUTION:**

**Align notches of inner socket and ring, and socket finisher when installing.**

Front Power Socket LH, Rear Power Socket (Cargo Bed)

INFOID:000000001505550

#### REMOVAL AND INSTALLATION

##### Removal

1. Disconnect the battery negative terminal.
2. Remove inner socket (1) from the ring (2) while pressing the hook (B) on the ring out from square hole (A).  
**NOTE:**  
Rear Power Socket (Cargo Bed) requires riveted finisher removal from bed prior to socket removal.
3. Disconnect power socket connector.
4. Remove ring from power socket finisher while pressing pawls.

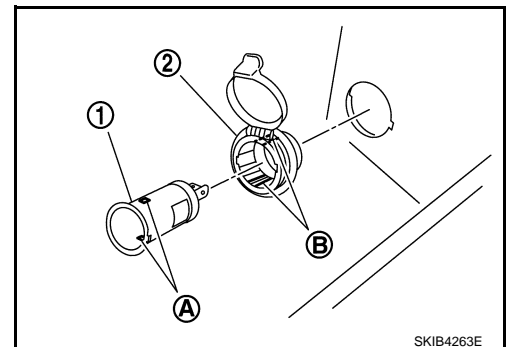

##### Installation

Installation is in the reverse order of removal.

##### **CAUTION:**

**Align notches of inner socket and ring, and socket finisher when installing.**