

SECTION **SRS**

SUPPLEMENTAL RESTRAINT SYSTEM (SRS)

A
B
C
D
E
F
G
H
I
J
K
L
M

CONTENTS

<p>PRECAUTIONS 3</p> <p> Precautions for Supplemental Restraint System (SRS) "AIR BAG" and "SEAT BELT PRE-TENSIONER" 3</p> <p> Precautions for SRS "AIR BAG" and "SEAT BELT PRE-TENSIONER" Service 3</p> <p> Occupant Classification System Precaution 3</p> <p>PREPARATION 4</p> <p> Special Service Tools 4</p> <p>SUPPLEMENTAL RESTRAINT SYSTEM (SRS) 5</p> <p> SRS Configuration 5</p> <p> Driver Air Bag Module 6</p> <p> Front Passenger Air Bag Module 6</p> <p> Front Side Air Bag 6</p> <p> Side Curtain Air Bag 6</p> <p> Front Seat Belt Pre-tensioner with Load Limiter 7</p> <p> Occupant Classification System (OCS) 7</p> <p> Direct-connect SRS Component Connectors 7</p> <p>TROUBLE DIAGNOSIS 9</p> <p> Trouble Diagnosis Introduction 9</p> <p> DIAGNOSIS FUNCTION 9</p> <p> HOW TO PERFORM TROUBLE DIAGNOSES FOR QUICK AND ACCURATE REPAIR 9</p> <p> WORK FLOW 10</p> <p> SRS Components Parts Location 11</p> <p> Schematic 12</p> <p> Wiring Diagram — SRS — 13</p> <p> CONSULT-II Function (AIR BAG) 19</p> <p> CONSULT-II Function 19</p> <p> HOW TO CHANGE SELF-DIAGNOSIS MODE WITH CONSULT-II 19</p> <p> HOW TO ERASE SELF-DIAGNOSIS RESULTS.. 20</p> <p> Self-Diagnosis Function (Without CONSULT-II) 20</p> <p> HOW TO CHANGE SELF-DIAGNOSIS MODE.. 21</p> <p> HOW TO ERASE SELF-DIAGNOSIS RESULTS.. 21</p> <p> SRS Operation Check 21</p> <p> DIAGNOSTIC PROCEDURE 1 21</p> <p> Trouble Diagnosis With CONSULT-II 23</p> <p> DIAGNOSTIC PROCEDURE 2 23</p>	<p> DIAGNOSTIC PROCEDURE 3 27</p> <p> DIAGNOSTIC PROCEDURE 4 28</p> <p> DIAGNOSTIC PROCEDURE 5 28</p> <p> Trouble Diagnosis Without CONSULT-II 30</p> <p> DIAGNOSTIC PROCEDURE 6 30</p> <p> WARNING LAMP FLASH CODE CHART 31</p> <p> Trouble Diagnosis: "AIR BAG" Warning Lamp Does Not Turn Off 35</p> <p> DIAGNOSTIC PROCEDURE 7 35</p> <p> Trouble Diagnosis: "AIR BAG" Warning Lamp Does Not Turn On 36</p> <p> DIAGNOSTIC PROCEDURE 8 36</p> <p>DRIVER AIR BAG MODULE 37</p> <p> Removal and Installation 37</p> <p> REMOVAL 37</p> <p> INSTALLATION 38</p> <p>SPIRAL CABLE 39</p> <p> Removal and Installation 39</p> <p> REMOVAL 39</p> <p> INSTALLATION 40</p> <p>FRONT PASSENGER AIR BAG MODULE 41</p> <p> Removal and Installation 41</p> <p> REMOVAL 41</p> <p> INSTALLATION 41</p> <p> WIRING HARNESS MODIFICATION 42</p> <p>SIDE CURTAIN AIR BAG MODULE 44</p> <p> Removal and Installation 44</p> <p> REMOVAL 44</p> <p> INSTALLATION 44</p> <p>CRASH ZONE SENSOR 46</p> <p> Removal and Installation 46</p> <p> REMOVAL 46</p> <p> INSTALLATION 46</p> <p>SIDE AIR BAG (SATELLITE) SENSOR 47</p> <p> Removal and Installation 47</p> <p> REMOVAL 47</p> <p> INSTALLATION 47</p> <p>FRONT SEAT BELT PRE-TENSIONER 48</p> <p> Removal and Installation 48</p>
--	---

SRS

DIAGNOSIS SENSOR UNIT	49	SRS INSPECTION (FOR FRONTAL COLLISION)	51
Removal and Installation	49	For Side and Rollover Collision	52
REMOVAL	49	WHEN SRS IS ACTIVATED IN THE SIDE OR	
INSTALLATION	49	ROLLOVER COLLISION	52
ECU DISCRIMINATED NO.	49	WHEN SRS IS NOT ACTIVATED IN THE SIDE	
OCCUPANT CLASSIFICATION SYSTEM CONTROL UNIT	50	OR ROLLOVER COLLISION	52
Removal and Installation	50	SRS INSPECTION (FOR SIDE AND ROLLOVER	
COLLISION DIAGNOSIS	51	COLLISION)	53
For Frontal Collision	51		

PRECAUTIONS

PRECAUTIONS

PFP:00001

Precautions for Supplemental Restraint System (SRS) “AIR BAG” and “SEAT BELT PRE-TENSIONER”

EHS0023J

The Supplemental Restraint System such as “AIR BAG” and “SEAT BELT PRE-TENSIONER”, used along with a front seat belt, helps to reduce the risk or severity of injury to the driver and front passenger for certain types of collision. This system includes seat belt switch inputs and dual stage front air bag modules. The SRS system uses the seat belt switches to determine the front air bag deployment, and may only deploy one front air bag, depending on the severity of a collision and whether the front occupants are belted or unbelted. Information necessary to service the system safely is included in the SRS and SB section of this Service Manual.

WARNING:

- To avoid rendering the SRS inoperative, which could increase the risk of personal injury or death in the event of a collision which would result in air bag inflation, all maintenance must be performed by an authorized NISSAN/INFINITI dealer.
- Improper maintenance, including incorrect removal and installation of the SRS, can lead to personal injury caused by unintentional activation of the system. For removal of Spiral Cable and Air Bag Module, see the SRS section.
- Do not use electrical test equipment on any circuit related to the SRS unless instructed to in this Service Manual. SRS wiring harnesses can be identified by yellow and/or orange harnesses or harness connectors.

Precautions for SRS “AIR BAG” and “SEAT BELT PRE-TENSIONER” Service

EHS0023K

- Do not use electrical test equipment to check SRS circuits unless instructed to in this Service Manual.
- Before servicing the SRS, turn ignition switch OFF, disconnect both battery cables and wait at least 3 minutes.
For approximately 3 minutes after the cables are removed, it is still possible for the air bags and seat belt pre-tensioners to deploy. Therefore, do not work on any SRS connectors or wires until at least 3 minutes have passed.
- The air bag diagnosis sensor unit must always be installed with the arrow mark “←” pointing toward the front of the vehicle for proper operation. Also check air bag diagnosis sensor unit for cracks, deformities or rust before installation and replace as required.
- The spiral cable must be aligned with the neutral position since its rotations are limited. Do not attempt to turn steering wheel or column after removal of steering gear.
- Handle air bag module carefully. Always place driver and front passenger air bag modules with the pad side facing upward and seat mounted front side air bag module standing with the stud bolt side facing down.
- Conduct self-diagnosis to check entire SRS for proper function after replacing any components.
- After air bag inflates, the front instrument panel assembly should be replaced if damaged.

Occupant Classification System Precaution

EHS0023L

Replace occupant classification system control unit and passenger front seat cushion as an assembly.

A
B
C
D
E
F
G
I
J
K
L
M

SRS

PREPARATION

PREPARATION

PFP:00002

Special Service Tools

EHS0023M

The actual shapes of Kent-Moore tools may differ from those of special service tools illustrated here.

Tool number (Kent-Moore No.) Tool name	Description
<p>— (J-42057-UPD) Air bag key set Part of kit (J-42057)</p> <div data-bbox="625 472 876 577" data-label="Image">Five cylindrical air bag keys are shown in a row. From left to right, they are labeled with the numbers 65, 71, 72, 76, and 121. Each key has a textured top surface with a central opening.</div> <p data-bbox="852 604 901 630">LRS210</p>	Removing and installing air bag lock

SUPPLEMENTAL RESTRAINT SYSTEM (SRS)

SUPPLEMENTAL RESTRAINT SYSTEM (SRS)

PF2:28556

SRS Configuration

EHS0023N

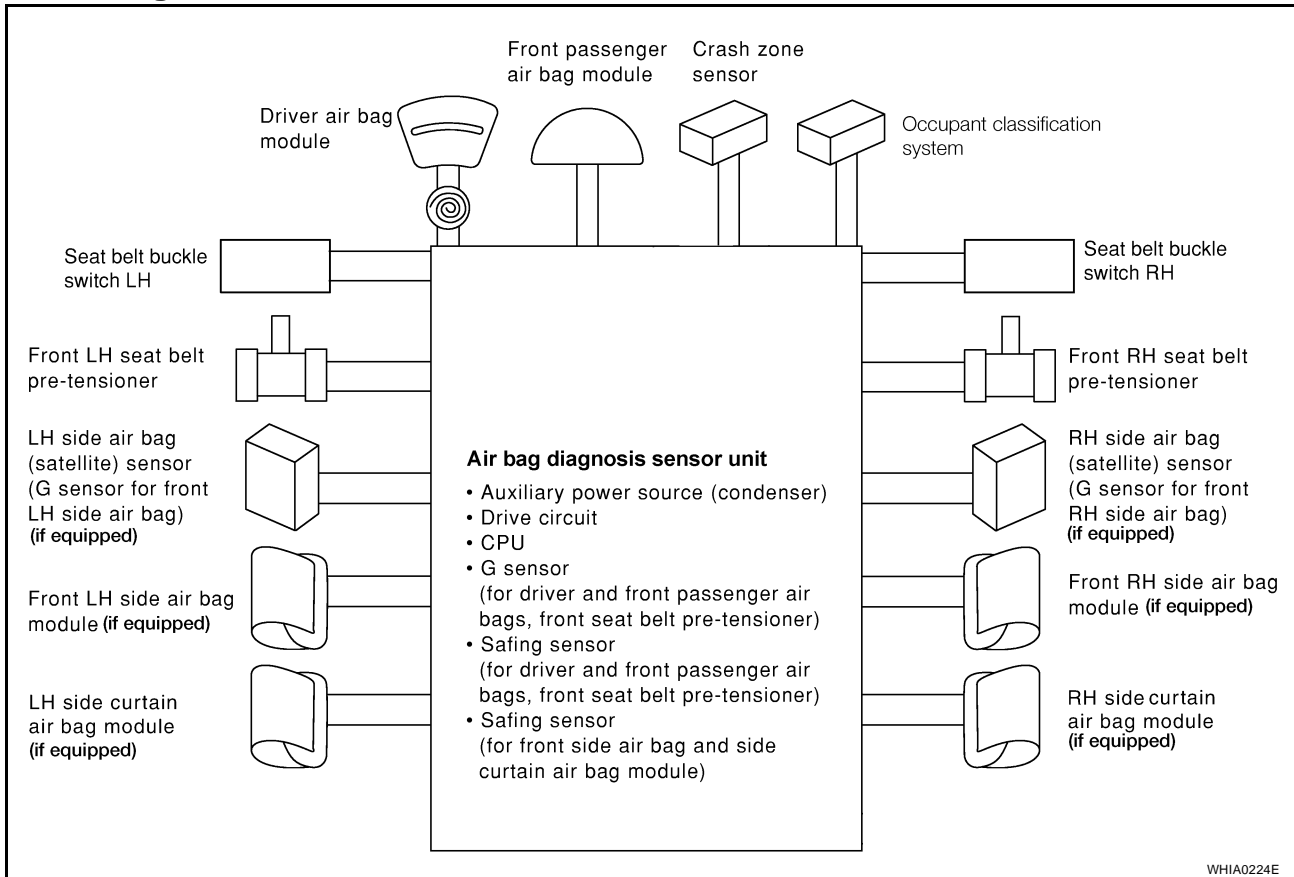

The air bag deploys if the air bag diagnosis sensor unit is activated while the ignition switch is in the ON or START position.

The collision modes for which supplemental restraint systems are activated are different among the SRS systems. For example, the driver air bag module, front passenger air bag module and front seat belt pre-tensioners are activated in a frontal collision but not in a side collision.

SRS configurations for some collision modes are as follows:

SRS configuration	Frontal collision	Left side collision	Right side collision	Rollover
Driver air bag module	×	—	—	—
Front passenger air bag module	×	—	—	—
Front LH seat belt pre-tensioner	×	—	—	×
Front RH seat belt pre-tensioner	×	—	—	×
Front LH side air bag module (if equipped)	—	×	—	—
Front RH side air bag module (if equipped)	—	—	×	—
LH side curtain air bag module (if equipped)	—	×	—	×
RH side curtain air bag module (if equipped)	—	—	×	×

SUPPLEMENTAL RESTRAINT SYSTEM (SRS)

Driver Air Bag Module

EHS00230

The driver air bag module is dual stage and located in the steering wheel assembly. It operates with the SRS system in a frontal collision exceeding a specified level.

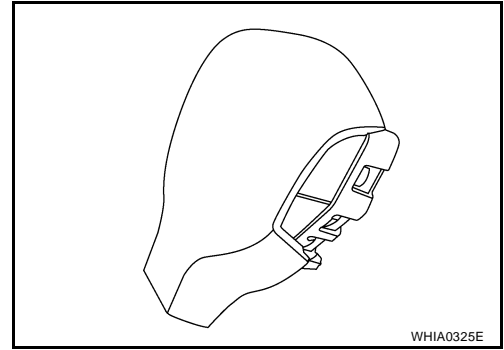

Front Passenger Air Bag Module

EHS0023P

The front passenger air bag module is located behind the instrument panel assembly. It operates with the SRS system in a frontal collision exceeding a specified level. Refer to [SRS-7, "Occupant Classification System \(OCS\)"](#) for more information.

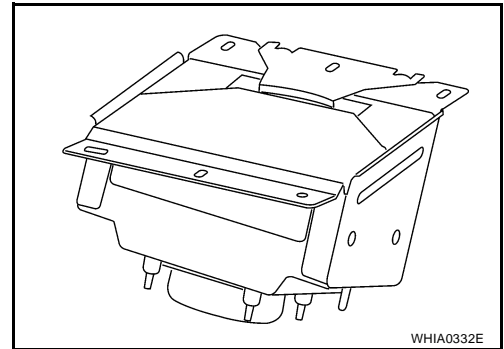

Front Side Air Bag

EHS0023Q

Front side air bag modules are built into the front seatback assemblies. Vehicles with side air bags are equipped with labels as shown.

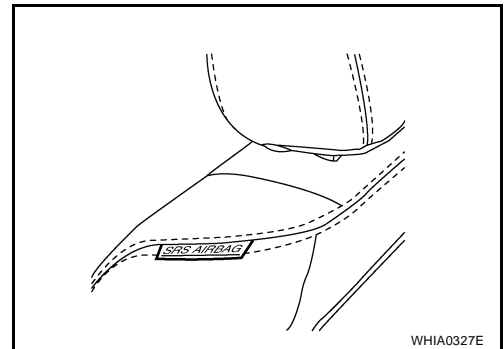

Side Curtain Air Bag

EHS0023R

Side curtain air bag modules are located above the vehicle headlining. Vehicles with side curtain air bags are equipped with labels as shown.



SUPPLEMENTAL RESTRAINT SYSTEM (SRS)

Front Seat Belt Pre-tensioner with Load Limiter

EHS0023S

The seat belt pre-tensioner system with load limiter is installed for both the driver's seat and the front passenger's seat. It operates simultaneously with the SRS air bag system in the event of a frontal collision with an impact exceeding a specified level.

When the frontal collision with an impact exceeding a specified level occurs, seat belt slack resulting from clothing or other factors is immediately taken up by the pre-tensioner. Vehicle passengers are securely restrained.

When passengers in a vehicle are thrown forward in a collision and the restraining force of the seat belt exceeds a specified level, the load limiter permits the specified extension of the seat belt by the twisting of the ELR shaft, and a relaxation of the chest-area seat belt web tension while maintaining force.

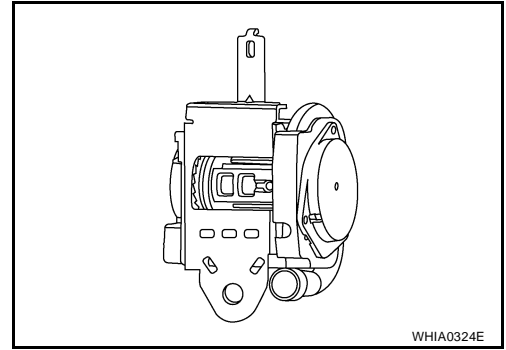

Occupant Classification System (OCS)

EHS0023T

The occupant classification system (OCS) identifies different size occupants, out of position occupants, and detects if child seat is present in the front passenger seat. The OCS receives inputs from the occupant classification sensor (located inside the passenger seat cushion assembly) and belt tension sensor (part of the passenger front seat belt assembly and located at the belt anchor location). Depending on classification of the passenger, the OCS sends a signal to the air bag diagnosis sensor unit. The air bag diagnosis sensor unit uses this signal and the seat belt buckle switch RH signal to determine deployment or non deployment of the passenger front air bag in the event of a collision. Depending on the signals received, the air bag diagnosis sensor unit can disable the passenger front air bag completely.

NOTE:

In case of customer concern, CONSULT-II can be used to confirm the passenger air bag status (readiness).

Passenger Air Bag Status Conditions

Front Passenger Seat (Condition)	PASS AIR BAG OFF Indicator (Status)	Passenger Air Bag Status (Readiness)	CONSULT-II Display
Seat occupied	OFF	Active (enabled)	ON
Seat occupied ^{NOTE}	ON	Deactivated (disabled)	OFF
Seat empty	OFF	Deactivated (disabled)	OFF

NOTE:

Passenger does not meet Occupant Classification System specifications for passenger air bag activation.

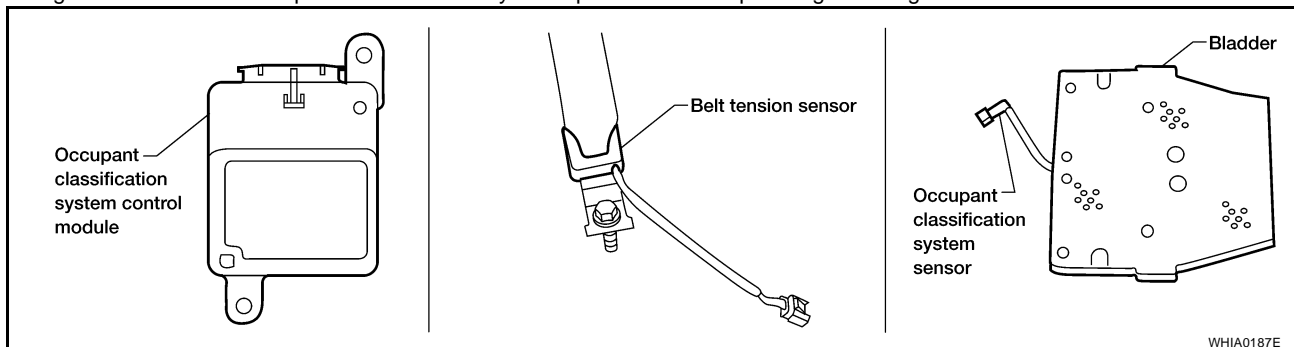

Direct-connect SRS Component Connectors

EHS0023U

The following SRS components use direct-connect style harness connectors.

- Driver front air bag module
- Passenger front air bag module
- LH side curtain air bag module
- RH side curtain air bag module
- Front LH seat belt pre-tensioner
- Front RH seat belt pre-tensioner

Always pull up to release locking tab prior to removing connector from SRS component.

SUPPLEMENTAL RESTRAINT SYSTEM (SRS)

Always push down to lock locking tab after installing connector to SRS component. When locked, the black locking tab is level with the connector housing.

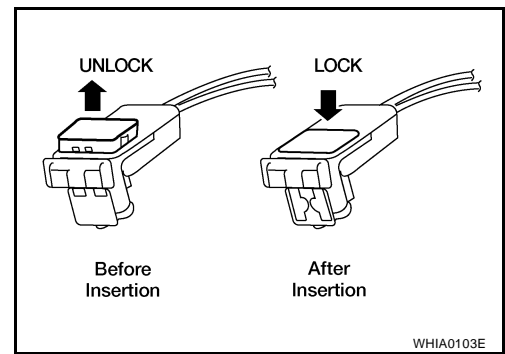

TROUBLE DIAGNOSIS

PFP:00004

TROUBLE DIAGNOSIS

Trouble Diagnosis Introduction

EHS0023V

CAUTION:

- Do not use electrical test equipment on any circuit related to the SRS unless instructed to do so in this Service Manual. SRS wiring harnesses can be identified by yellow and/or orange harness connectors.
- Do not attempt to repair, splice or modify SRS wiring harnesses. If a harness is damaged, replace it with a new one.
- Keep ground connections clean.

DIAGNOSIS FUNCTION

The SRS self-diagnosis results can be read by using "AIR BAG" warning lamp and/or CONSULT-II.

The User mode is exclusively prepared for the customer (driver). This mode warns the driver of a system malfunction through the operation of the "AIR BAG" warning lamp.

The Diagnosis mode allows the technician to locate and inspect the malfunctioning part.

The mode applications for the "AIR BAG" warning lamp and CONSULT-II are as follows:

	User mode	Diagnosis mode	Display type
"AIR BAG" warning lamp	X	X	ON-OFF operation
CONSULT-II	—	X	Monitoring

HOW TO PERFORM TROUBLE DIAGNOSES FOR QUICK AND ACCURATE REPAIR

A good understanding of the malfunction conditions can make troubleshooting faster and more accurate.

In general, each customer feels differently about a malfunction. It is important to fully understand the symptoms or conditions for a customer complaint.

Information From Customer

WHAT - Vehicle model

WHEN - Date, Frequencies

WHERE - Road conditions

HOW - Operating conditions, Symptoms

Preliminary Check

Check that the following parts are in good order.

- Battery (Refer to [SC-4, "How to Handle Battery"](#) .)
- Fuse (Refer to [SRS-13, "Wiring Diagram — SRS —"](#) .)
- System component-to-harness connections

A

B

C

D

E

F

G

SRS

I

J

K

L

M

TROUBLE DIAGNOSIS

WORK FLOW

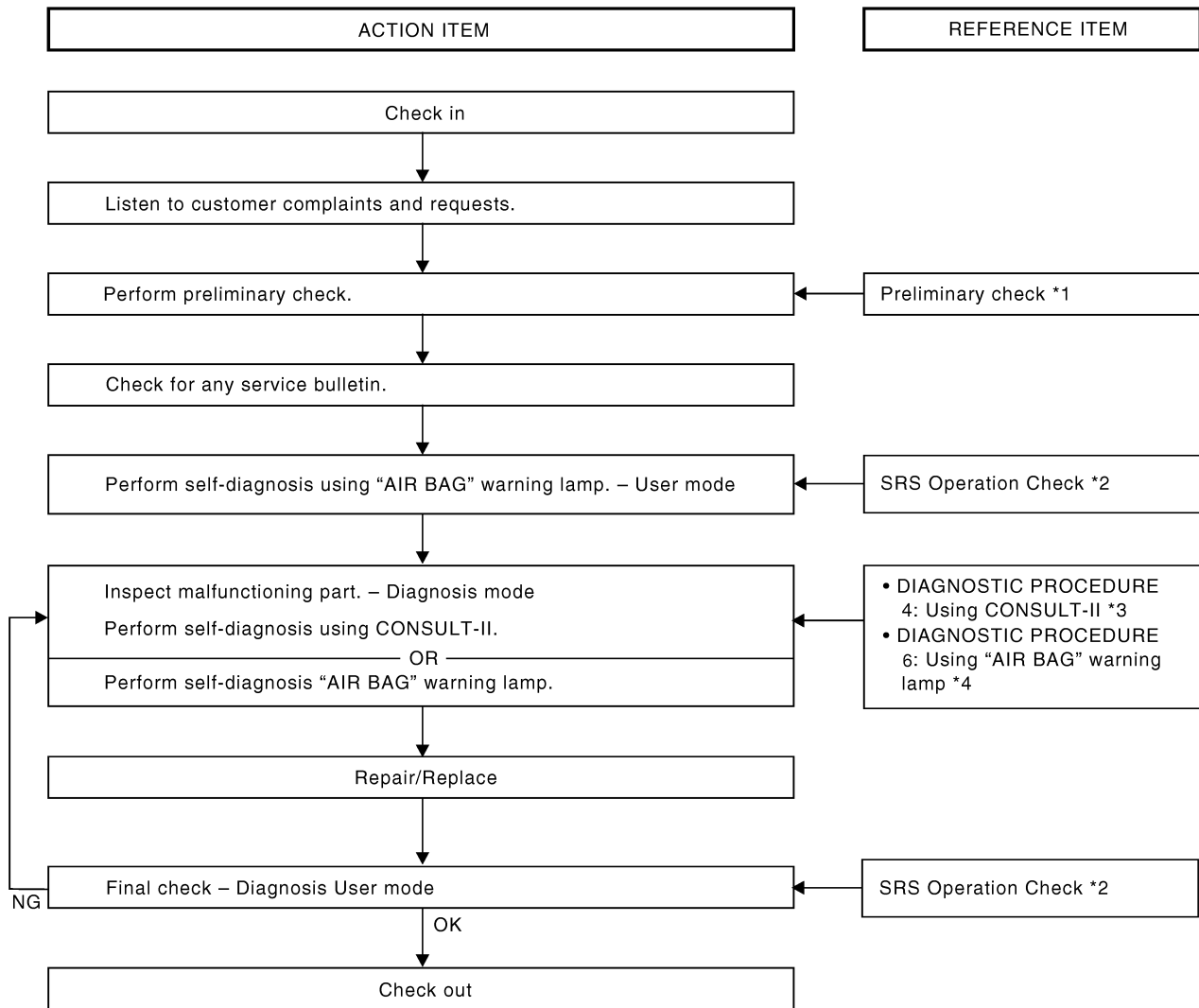

WHIA0098E

*1: [SRS-9](#)

*2: [SRS-21](#)

*3: [SRS-28](#)

*4: [SRS-30](#)

TROUBLE DIAGNOSIS

SRS Components Parts Location

EHS0023W

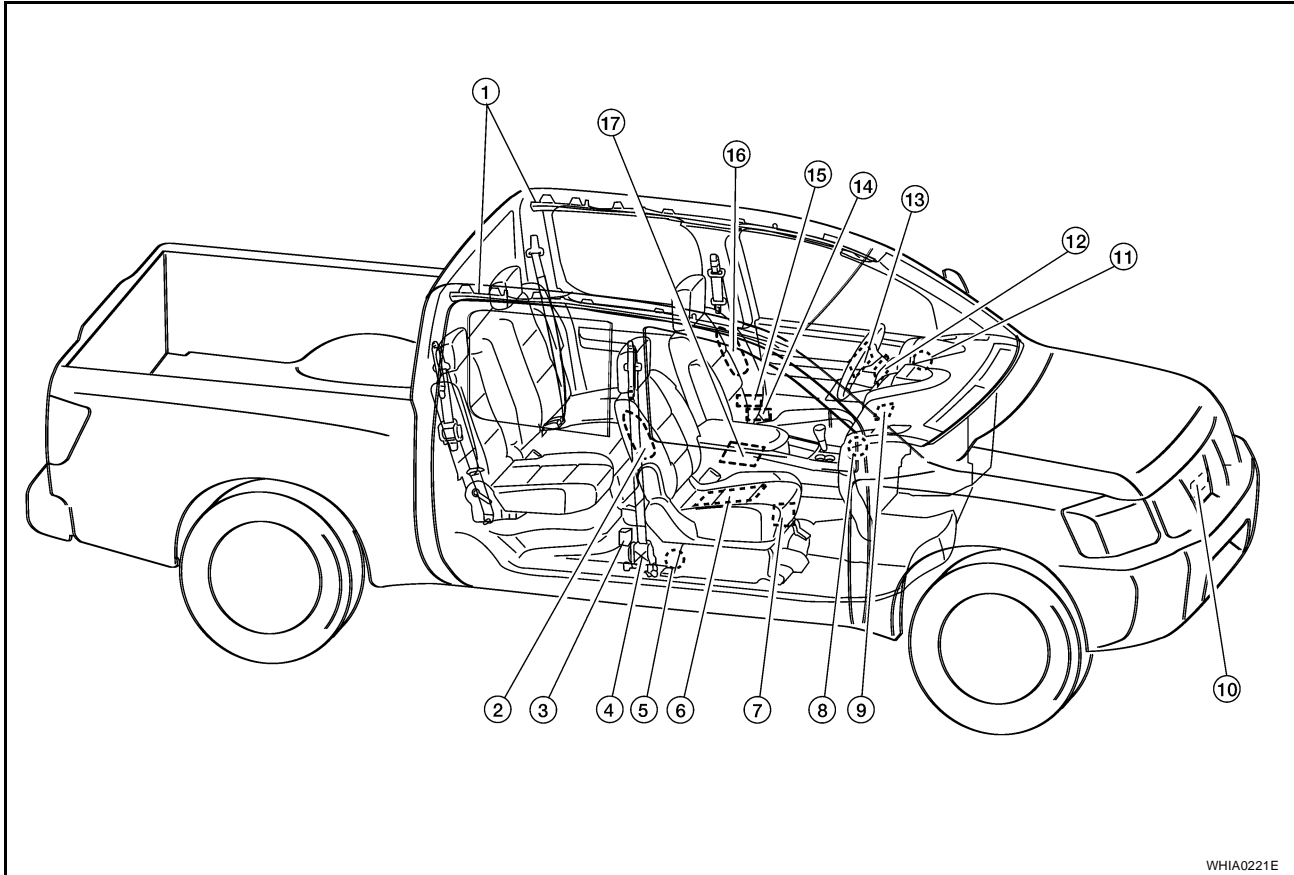

WHIA0221E

- | | | |
|--|---|--|
| 1. Side curtain air bag modules (If equipped) | 2. Front RH side air bag module (If equipped) | 3. RH side air bag (satellite) sensor (If equipped) |
| 4. Front RH seatbelt pre-tensioner | 5. Belt tension sensor | 6. Occupant classification system sensor |
| 7. Occupant classification system control unit | 8. Front passenger air bag off indicator | 9. Front passenger air bag module |
| 10. Crash zone sensor | 11. Air bag warning lamp | 12. Spiral cable |
| 13. Driver air bag module | 14. Front LH seatbelt pre-tensioner | 15. LH side air bag (satellite) sensor (If equipped) |
| 16. Front LH side air bag module (If equipped) | 17. Air bag diagnosis sensor unit | |

A
B
C
D
E
F
G
SRS
I
J
K
L
M

TROUBLE DIAGNOSIS

Schematic

EHS0023X

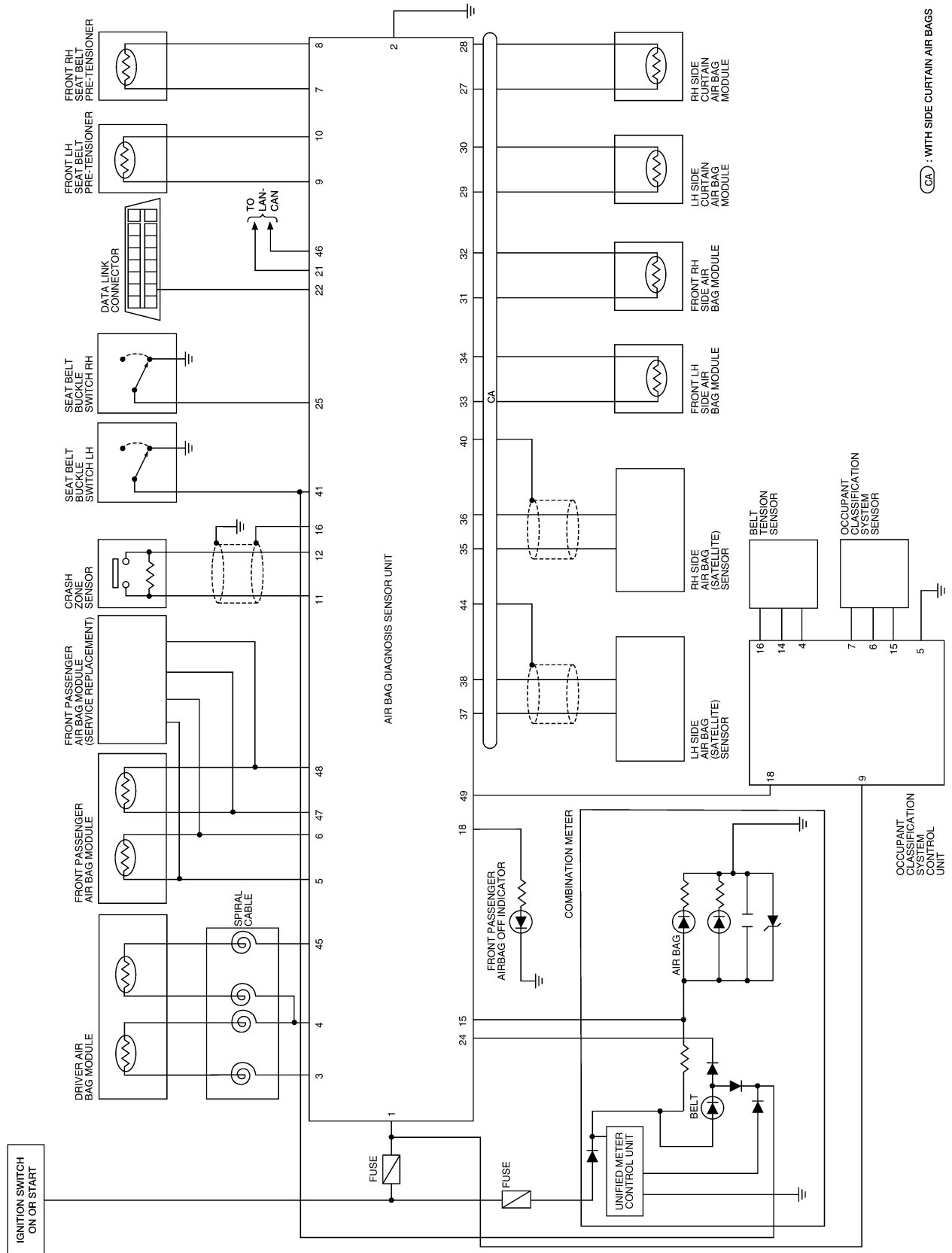

WHWA0214E

TROUBLE DIAGNOSIS

Wiring Diagram — SRS —

EHS0023Y

SRS-SRS-01

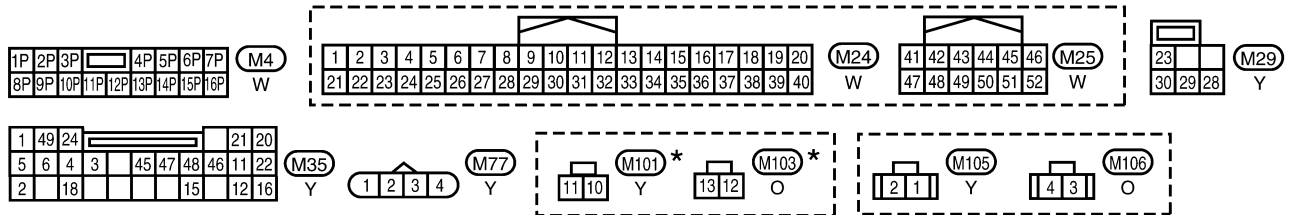
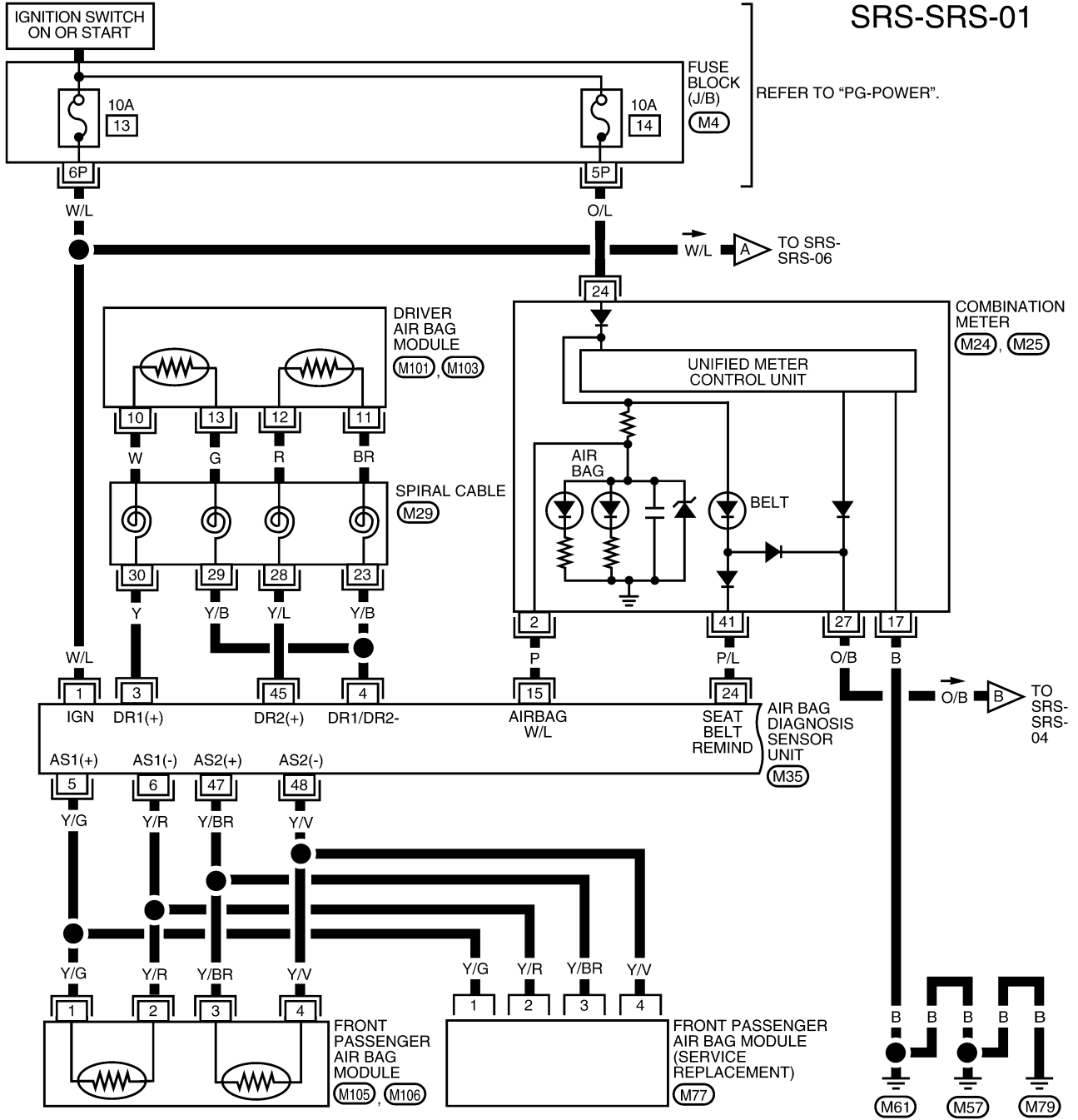

* : THIS CONNECTOR IS NOT SHOWN IN "HARNESS LAYOUT" OF PG SECTION.

WHWA0310E

TROUBLE DIAGNOSIS

SRS-SRS-02

— : DATA LINE

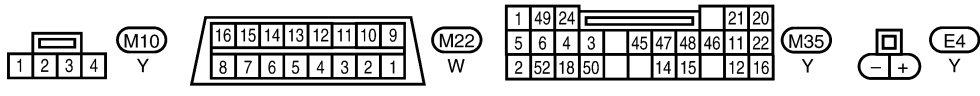
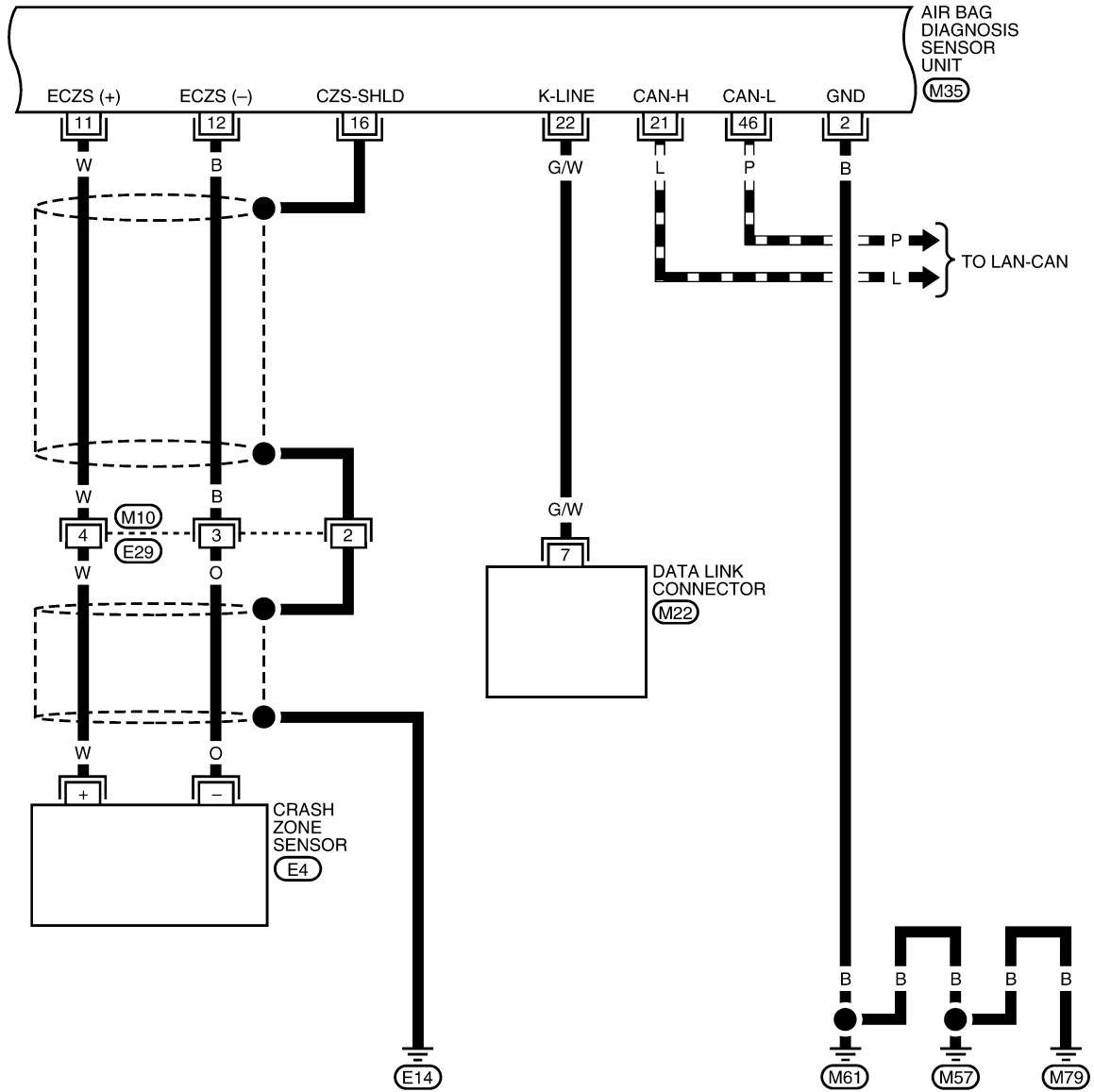

WHWA0216E

TROUBLE DIAGNOSIS

SRS-SRS-03

CA : WITH SIDE CURTAIN
AIR BAGS

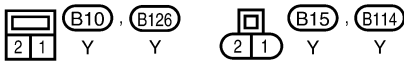
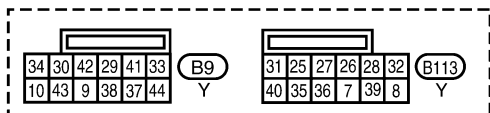
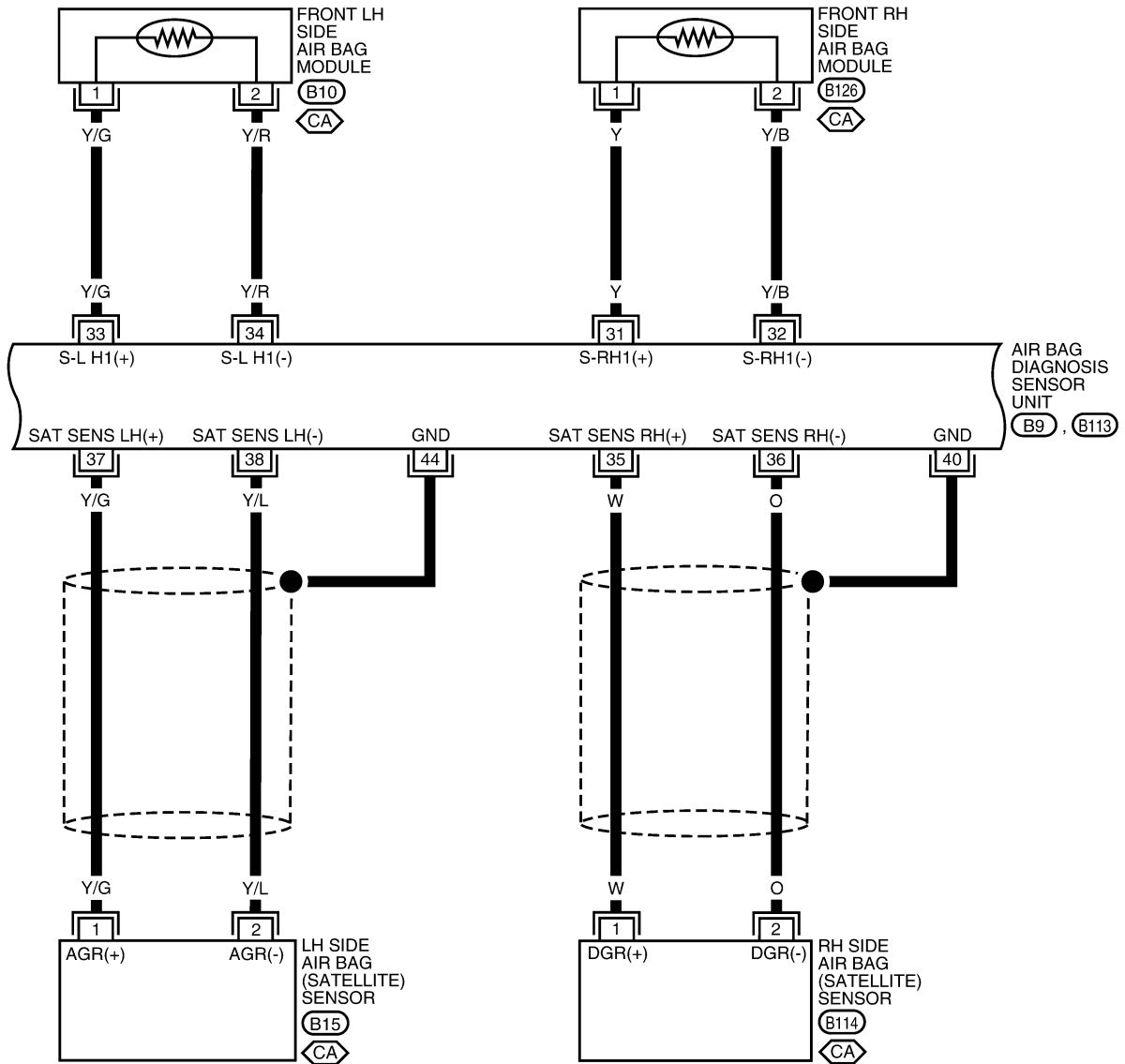

WHWA0217E

TROUBLE DIAGNOSIS

SRS-SRS-04

CA : WITH SIDE CURTAIN AIR BAGS

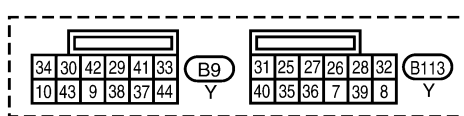
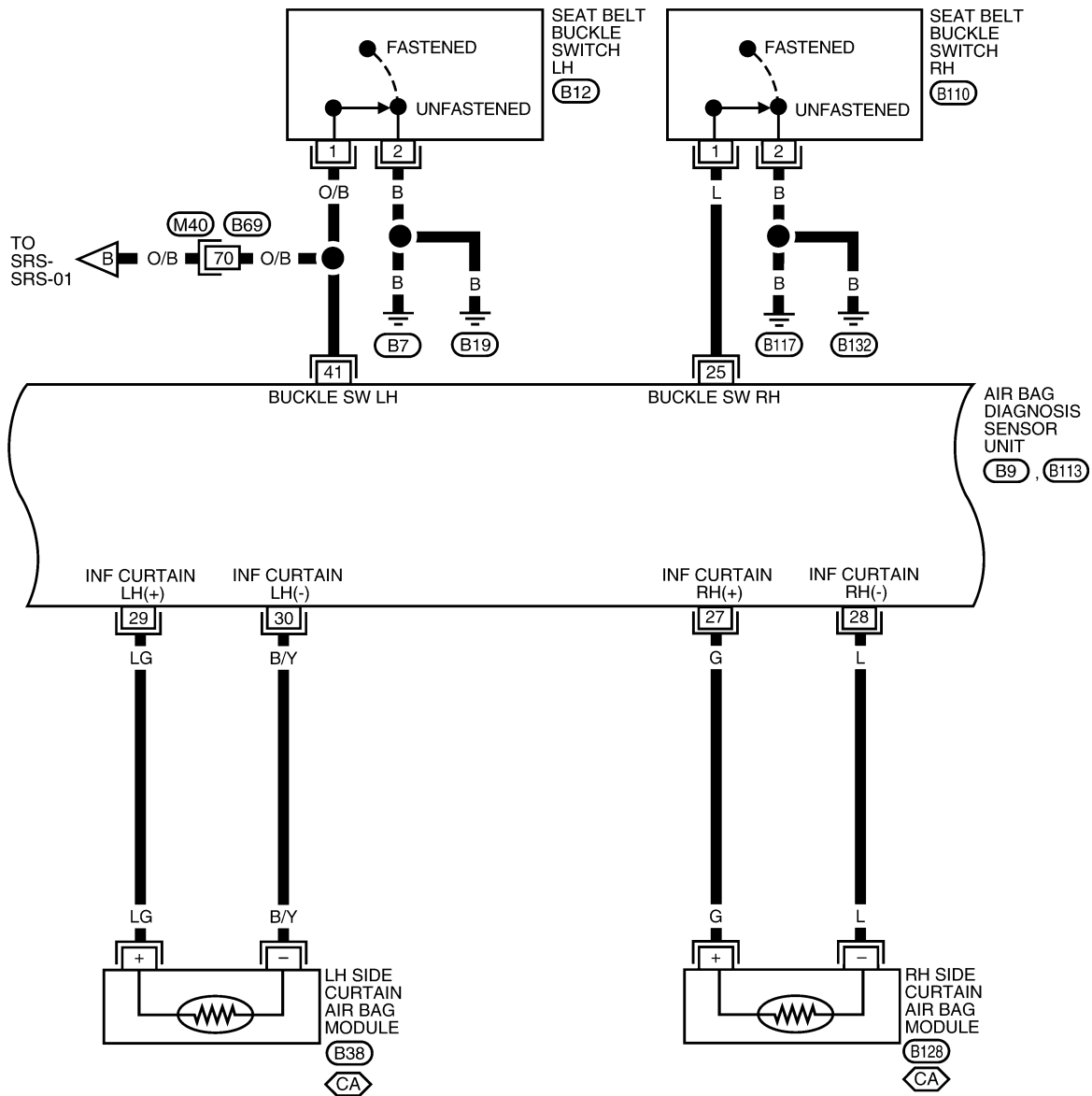

REFER TO THE FOLLOWING.
 M40 - SUPER MULTIPLE JUNCTION (SMJ)

WHWA0218E

TROUBLE DIAGNOSIS

SRS-SRS-05

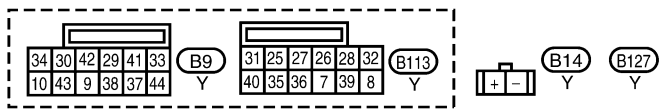
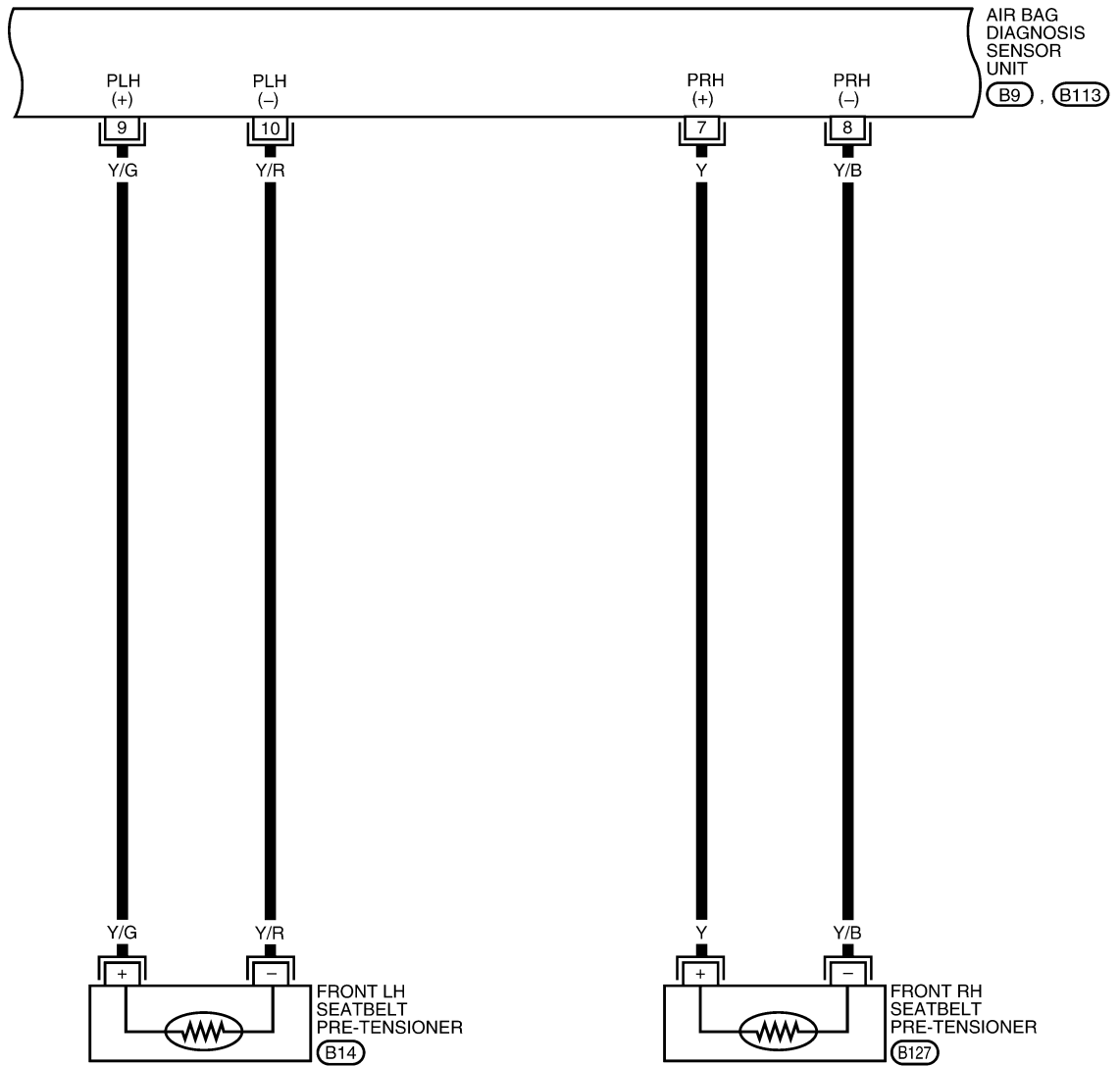

WHWA0125E

TROUBLE DIAGNOSIS

SRS-SRS-06

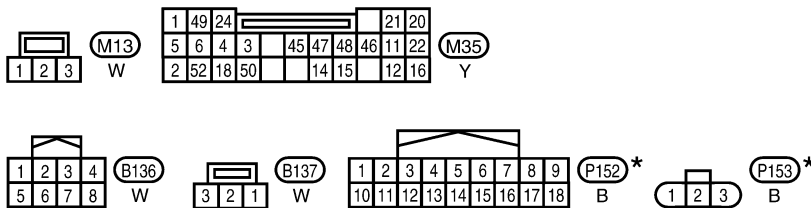
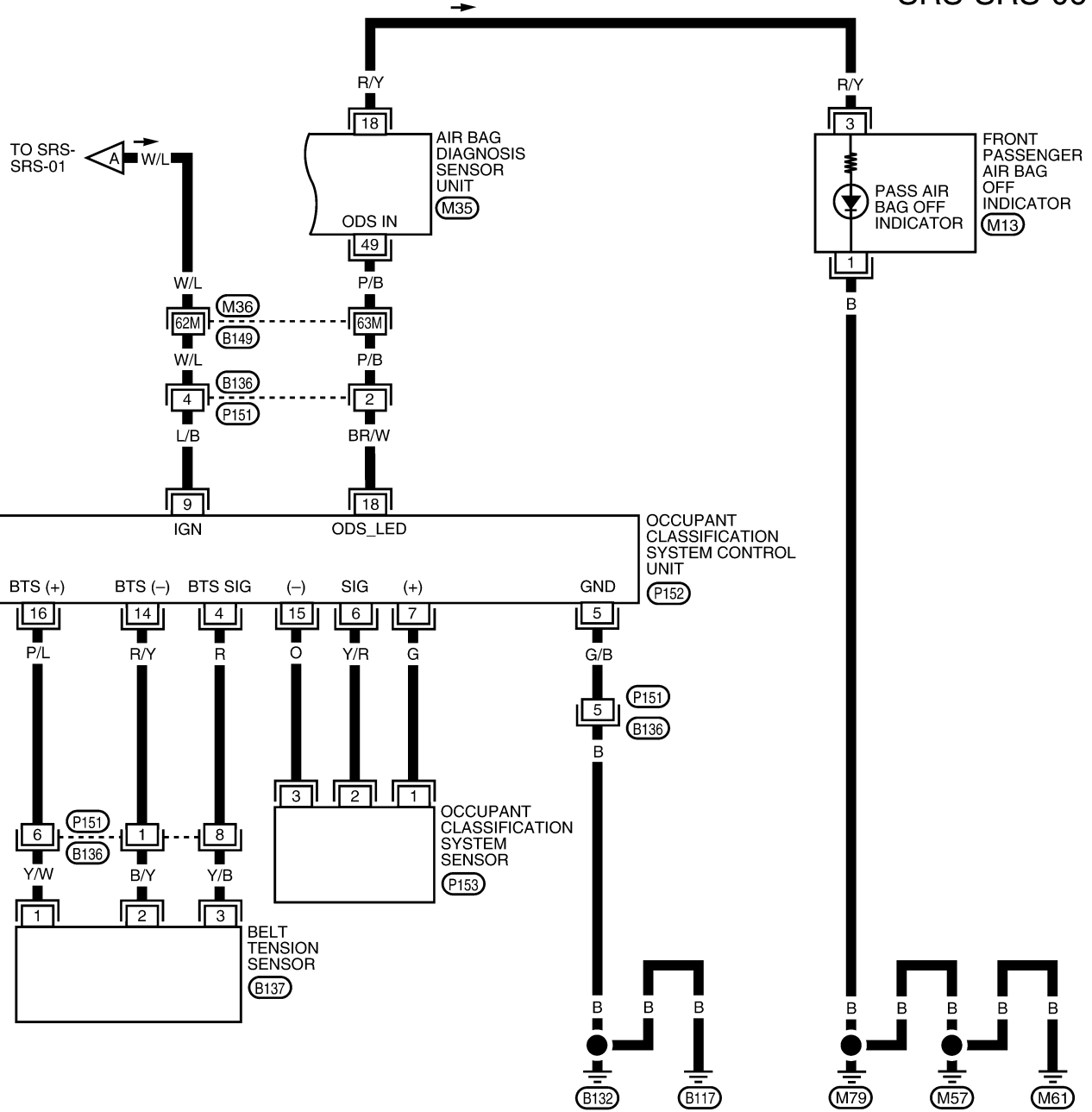

REFER TO THE FOLLOWING.
 (M36) - SUPER MULTIPLE JUNCTION (SMJ)

*: THIS CONNECTOR IS NOT SHOWN IN "HARNESS LAYOUT" OF PG SECTION.

WHWA0307E

TROUBLE DIAGNOSIS

CONSULT-II Function (AIR BAG)

EHS0023Z

CONSULT-II can display each diagnostic item using the diagnostic test modes shown following.

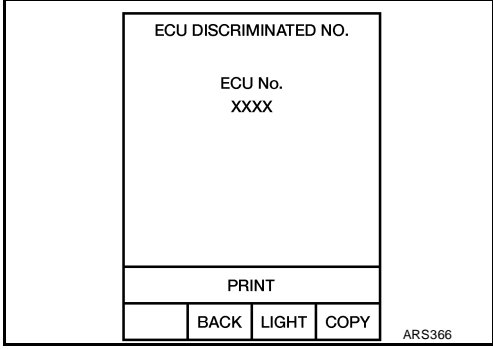
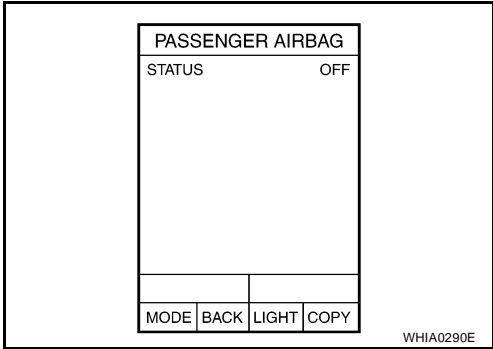
AIR BAG diagnostic mode	Description
SELF-DIAG [CURRENT]	A current Self-diagnosis result (also indicated by the number of warning lamp flashes in the Diagnosis mode) is displayed on the CONSULT-II screen in real time. This refers to a malfunctioning part requiring repairs.
SELF-DIAG [PAST]	Diagnosis results previously stored in the memory are displayed on the CONSULT-II screen. The stored results will remain until memory erasing is executed.
TROUBLE DIAG RECORD	With TROUBLE DIAG RECORD, diagnosis results previously erased by a reset operation can be displayed on the CONSULT-II screen.
ECU DISCRIMINATED NO.	<p>The air bag diagnosis sensor unit for each vehicle model is assigned with its own, individual classification number. This number will be displayed on the CONSULT-II screen, as shown. When replacing the air bag diagnosis sensor unit, refer to the part number for the compatibility. After installation, replacement with a correct unit can be checked by confirming this classification number on the CONSULT-II screen.</p> <p>The air bag diagnosis sensor unit discriminated numbers assigned are F647 with front side and side curtain air bag modules and F646 without front side and side curtain air bag modules.</p> 
PASSENGER AIR BAG	<p>The STATUS (readiness) of the front passenger air bag module is displayed. The STATUS displayed (ON/OFF) depends on the signals supplied to the occupant classification system control module and air bag diagnosis sensor unit. Refer to SRS-7, "Occupant Classification System (OCS)" for more information.</p> 

A
B
C
D
E
F
G
SRS
I
J
K
L
M

CONSULT-II Function

EHS00240

Ⓟ HOW TO CHANGE SELF-DIAGNOSIS MODE WITH CONSULT-II

From User Mode to Diagnosis Mode

After selecting "AIR BAG" on the "SELECT SYSTEM" screen, User mode automatically changes to Diagnosis mode.

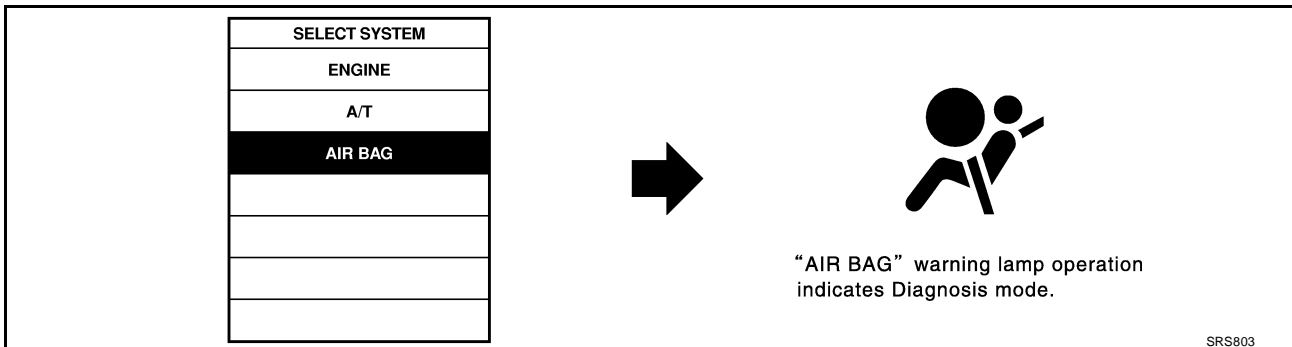

From Diagnosis Mode to User Mode

To return to User mode from Diagnosis mode, touch "BACK" key of CONSULT-II until "SELECT SYSTEM" appears, Diagnosis mode automatically changes to User mode.

TROUBLE DIAGNOSIS

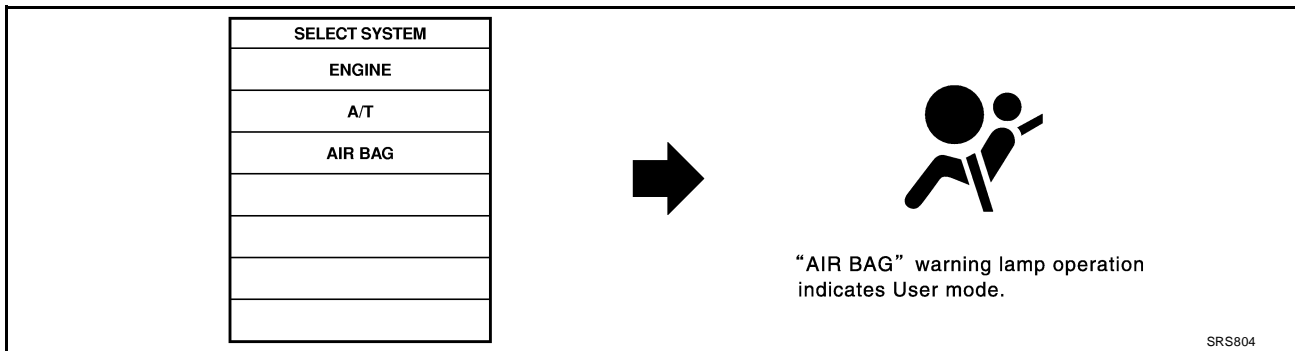

SRS804

HOW TO ERASE SELF-DIAGNOSIS RESULTS

- "SELF-DIAG [CURRENT]"

A current self-diagnosis result is displayed on the CONSULT-II screen in real time.

After the malfunction is repaired completely, no malfunction is detected on "SELF-DIAG [CURRENT]".

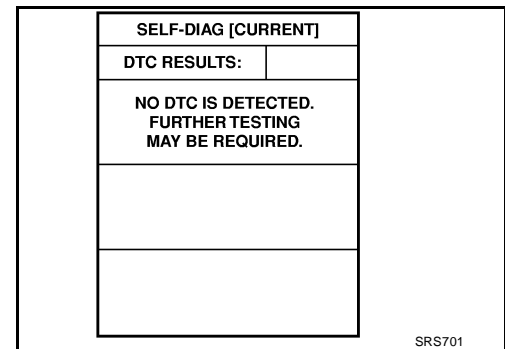

SRS701

- "SELF-DIAG [PAST]"

Return to the "SELF-DIAG [CURRENT]" CONSULT-II screen by touching "BACK" key of CONSULT-II and select "SELF-DIAG [PAST]" in SELECT DIAG MODE. Touch "ERASE" in "SELF-DIAG [PAST]" mode.

NOTE:

If the memory of the malfunction in "SELF-DIAG [PAST]" is not erased, the User mode will continue to show the system malfunction by the operation of the warning lamp even if the malfunction is repaired completely.

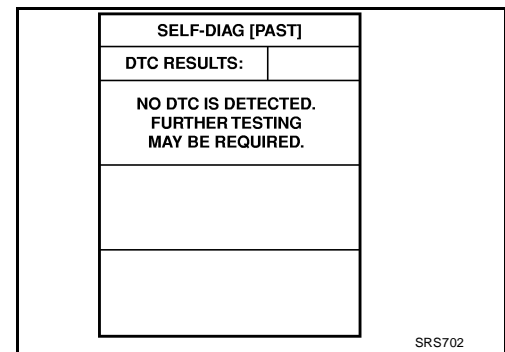

SRS702

- "TROUBLE DIAG RECORD"

The memory of "TROUBLE DIAG RECORD" cannot be erased.

Self-Diagnosis Function (Without CONSULT-II)

EHS00241

- The reading of these results is accomplished using one of two modes — "User mode" and "Diagnosis mode".
- After a malfunction is repaired, turn the ignition switch OFF for at least one second, then back ON. Diagnosis mode returns to the User mode. At that time, the self-diagnostic result is cleared.

TROUBLE DIAGNOSIS

HOW TO CHANGE SELF-DIAGNOSIS MODE

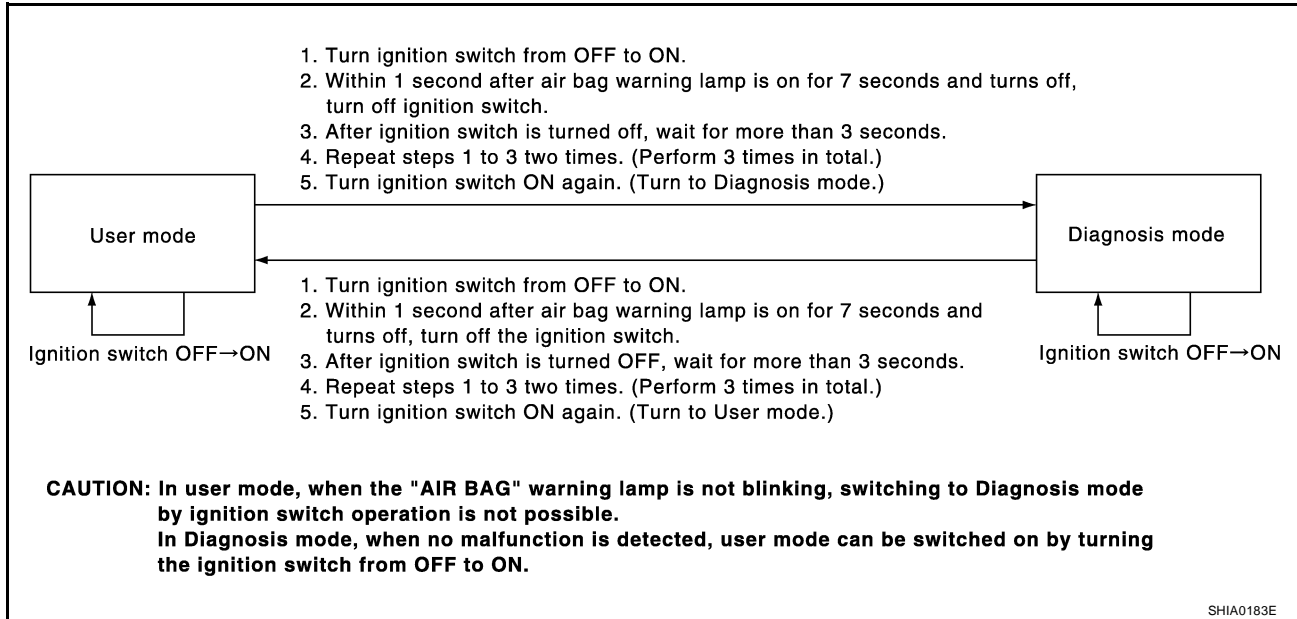

HOW TO ERASE SELF-DIAGNOSIS RESULTS

After a malfunction is repaired, turn the ignition switch OFF for at least one second, then back ON. Diagnosis mode returns to the User mode. At that time, the self-diagnostic result is cleared.

SRS Operation Check DIAGNOSTIC PROCEDURE 1

EHS00242

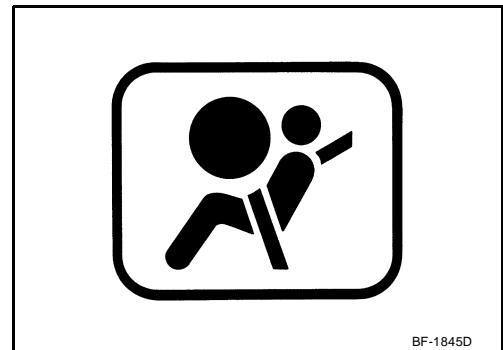

Checking SRS Operation Using "AIR BAG" Warning Lamp—User Mode

1. Turn the ignition switch from OFF to ON, and check that the air bag warning lamp blinks.
2. Compare the SRS air bag warning lamp blinking pattern with the examples.

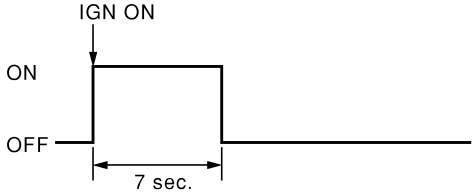
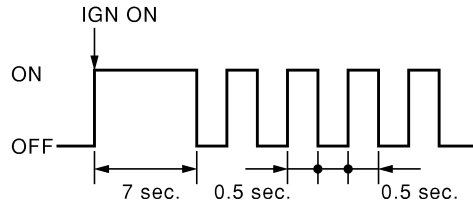
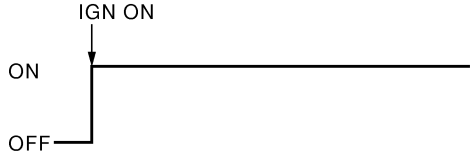

TROUBLE DIAGNOSIS

Warning lamp examples

"AIR BAG" warning lamp operation-User mode-	SRS condition	Reference item
 <p style="text-align: right; font-size: small;">SHIA0011E</p>	<ul style="list-style-type: none"> ● No malfunction is detected. ● No further action is necessary. 	—
 <p style="text-align: right; font-size: small;">SHIA0012E</p>	<p>The system is malfunctioning and needs to be repaired as indicated.</p>	<p>Go to SRS-23, "DIAGNOSTIC PROCEDURE 2" with CONSULT-II or SRS-30, "DIAGNOSTIC PROCEDURE 6" without CONSULT-II.</p>
 <p style="text-align: right; font-size: small;">SHIA0013E</p>	<ul style="list-style-type: none"> ● Air bag is deployed. ● Seat belt pre-tensioner is deployed. 	<p>Go to SRS-51, "COLLISION DIAGNOSIS" .</p>
 <p style="text-align: right; font-size: small;">SHIA0014E</p>	<ul style="list-style-type: none"> ● Air bag diagnosis sensor unit is malfunctioning. ● Air bag power supply circuit is malfunctioning. ● SRS air bag warning lamp circuit is malfunctioning. 	<p>Go to SRS-35, "Trouble Diagnosis: "AIR BAG" Warning Lamp Does Not Turn Off" .</p>

TROUBLE DIAGNOSIS

EHS00243

Trouble Diagnosis With CONSULT-II DIAGNOSTIC PROCEDURE 2

Refer to [GI-38, "CONSULT-II Start Procedure"](#) .
Diagnostic code is displayed on "SELF-DIAG [CURRENT]".

SELF-DIAG [CURRENT]
DTC RESULTS
DRIVER AIRBAG MODULE [OPEN] [B1049]

WHIA0151E

If no malfunction is detected on "SELF-DIAG [CURRENT]", but malfunction is detected in "SRS Operation Check", the following cases may exist:

- "SELF-DIAG [PAST]" memory might not be erased.
- The SRS system malfunctions intermittently.

Refer to [SRS-28, "DIAGNOSTIC PROCEDURE 4"](#)

SELF-DIAG [CURRENT]
DTC RESULTS:
NO DTC IS DETECTED. FURTHER TESTING MAY BE REQUIRED.

SRS701

A
B
C
D
E
F
G
SRS

CONSULT-II Diagnostic Code Chart

Diagnostic item	Explanation	Repair order Recheck SRS at each replacement
NO DTC IS DETECTED	Malfunction is indicated by the "AIR BAG" warning lamp in User mode.	Low battery voltage (Less than 9V)
		"SELF-DIAG [PAST]" memory might not be erased.
		Intermittent malfunction has been detected in the past.
	No malfunction is detected in User mode.	—
DRIVER AIRBAG MODULE [OPEN] [B1049] or [B1054]	Driver air bag module circuit is open (including the spiral cable).	1. Visually check the wiring harness connection. 2. Replace the harness if it has visible damage.
DRIVER AIRBAG MODULE [VB-SHORT] [B1050] or [B1055]	Driver air bag module circuit is shorted to some power supply circuit (including the spiral cable).	3. Replace driver air bag module. 4. Replace the spiral cable.
DRIVER AIRBAG MODULE [GND-SHORT] [B1051] or [B1056]	Driver air bag module circuit is shorted to ground (including the spiral cable).	5. Replace the air bag diagnosis sensor unit. 6. Replace the related harness.
DRIVER AIRBAG MODULE [SHORT] [B1052] or [B1057]	Driver air bag module circuits are shorted to each other.	

I
J
K
L
M

TROUBLE DIAGNOSIS

Diagnostic item	Explanation	Repair order Recheck SRS at each replacement
ASSIST A/B MODULE [OPEN] [B1065] or [B1070]	Front passenger air bag module circuit is open.	<ol style="list-style-type: none"> 1. Visually check the wiring harness connection. 2. Replace the harness if it has visible damage. 3. Replace front passenger air bag module. 4. Replace the air bag diagnosis sensor unit. 5. Replace the related harness.
ASSIST A/B MODULE [VB-SHORT] [B1066] or [B1071]	Front passenger air bag module circuit is shorted to some power supply circuit.	
ASSIST A/B MODULE [GND-SHORT] [B1067] or [B1072]	Front passenger air bag module circuit is shorted to ground.	
ASSIST A/B MODULE [SHORT] [B1068] or [B1073]	Front passenger air bag module circuits are shorted to each other.	
CRASH ZONE SEN [UNIT FAIL] [B1033] or [B1034] CRASH ZONE SEN [COMM FAIL] [B1035]	Crash zone sensor	<ol style="list-style-type: none"> 1. Visually check the wiring harness connection. 2. Replace the harness if it has visible damage. 3. Replace the crash zone sensor. 4. Replace the air bag diagnosis sensor unit. 5. Replace the related harness.
SIDE MODULE LH [OPEN] [B1134]	Front LH side air bag module circuit is open.	<ol style="list-style-type: none"> 1. Visually check the wiring harness connection. 2. Replace the harness if it has visible damage. 3. Replace front LH seat back assembly (front LH side air bag module). 4. Replace the air bag diagnosis sensor unit. 5. Replace the related harness.
SIDE MODULE LH [VB-SHORT] [B1135]	Front LH side air bag module circuit is shorted to some power supply circuit.	
SIDE MODULE LH [GND-SHORT] [B1136]	Front LH side air bag module circuit is shorted to ground.	
SIDE MODULE LH [SHORT] [B1137]	Front LH side air bag module circuits are shorted to each other.	
SIDE MODULE RH [OPEN] [B1129]	Front RH side air bag module circuit is open.	<ol style="list-style-type: none"> 1. Visually check the wiring harness connection. 2. Replace the harness if it has visible damage. 3. Replace front RH seat back assembly (front RH side air bag module). 4. Replace the air bag diagnosis sensor unit. 5. Replace the related harness.
SIDE MODULE RH [VB-SHORT] [B1130]	Front RH side air bag module circuit is shorted to some power supply circuit.	
SIDE MODULE RH [GND-SHORT] [B1131]	Front RH side air bag module circuit is shorted to ground.	
SIDE MODULE RH [SHORT] [B1132]	Front RH side air bag module circuits are shorted to each other.	
SATELLITE SENS LH [UNIT FAIL] [B1118] or [B1119] SATELLITE SENS LH [COMM FAIL] [B1120]	LH side air bag (satellite) sensor	<ol style="list-style-type: none"> 1. Visually check the wiring harness connection. 2. Replace the harness if it has visible damage. 3. Replace the LH side air bag (satellite) sensor. 4. Replace the air bag diagnosis sensor unit. 5. Replace the related harness.

TROUBLE DIAGNOSIS

Diagnostic item	Explanation	Repair order Recheck SRS at each replacement	
SATELLITE SENS RH [UNIT FAIL] [B1113] or [B1114] SATELLITE SENS RH [COMM FAIL] [B1115]	RH side air bag (satellite) sensor	<ol style="list-style-type: none"> 1. Visually check the wiring harness connection. 2. Replace the harness if it has visible damage. 3. Replace the RH side air bag (satellite) sensor. 4. Replace the air bag diagnosis sensor unit. 5. Replace the related harness. 	A B C
PRE-TEN FRONT LH [OPEN] [B1086]	The circuit for front LH seat belt pre-tensioner is open.	<ol style="list-style-type: none"> 1. Visually check the wiring harness connections. 2. Replace the harness if it has visible damage. 	D
PRE-TEN FRONT LH [VB-SHORT] [B1087]	The circuit for front LH seat belt pre-tensioner is shorted to some power supply circuit.	<ol style="list-style-type: none"> 3. Replace front LH seat belt pre-tensioner. 	E
PRE-TEN FRONT LH [GND-SHORT] [B1088]	The circuit for front LH seat belt pre-tensioner is shorted to ground.	<ol style="list-style-type: none"> 4. Replace the air bag diagnosis sensor unit. 	F
PRE-TEN FRONT LH [SHORT] [B1089]	The circuits for the front LH seat belt pre-tensioner are shorted to each other.	<ol style="list-style-type: none"> 5. Replace the related harness. 	G
PRE-TEN FRONT RH [OPEN] [B1081]	The circuit for front RH seat belt pre-tensioner is open.	<ol style="list-style-type: none"> 1. Visually check the wiring harness connections. 	SRS
PRE-TEN FRONT RH [VB-SHORT] [B1082]	The circuit for front RH seat belt pre-tensioner is shorted to some power supply circuit.	<ol style="list-style-type: none"> 2. Replace the harness if it has visible damage. 	I
PRE-TEN FRONT RH [GND-SHORT] [B1083]	The circuit for front RH seat belt pre-tensioner is shorted to ground.	<ol style="list-style-type: none"> 3. Replace front RH seat belt pre-tensioner. 	J
PRE-TEN FRONT RH [SHORT] [B1084]	The circuits for the front RH seat belt pre-tensioner are shorted to each other.	<ol style="list-style-type: none"> 4. Replace the air bag diagnosis sensor unit. 5. Replace the related harness. 	K
CURTAIN MODULE LH [OPEN] [B1150]	The LH side rear curtain air bag module circuit is open.	<ol style="list-style-type: none"> 1. Visually check the wiring harness connection. 	L
CURTAIN MODULE LH [VB-SHORT] [B1151]	The LH side rear curtain air bag module circuit is shorted to some power supply circuits.	<ol style="list-style-type: none"> 2. Replace the harness if it has visible damage. 	M
CURTAIN MODULE LH [GND-SHORT] [B1152]	The LH side rear curtain air bag module circuit is shorted to ground.	<ol style="list-style-type: none"> 3. Replace LH side curtain air bag module. 	
CURTAIN MODULE LH [SHORT] [B1153]	The circuits for the LH side rear curtain air bag module are shorted to each other.	<ol style="list-style-type: none"> 4. Replace the air bag diagnosis sensor unit. 5. Replace the related harness. 	

TROUBLE DIAGNOSIS

Diagnostic item	Explanation	Repair order Recheck SRS at each replacement
CURTAIN MODULE RH [OPEN] [B1145]	The RH side rear curtain air bag module circuit is open.	<ol style="list-style-type: none"> 1. Visually check the wiring harness connection. 2. Replace the harness if it has visible damage. 3. Replace RH side curtain air bag module. 4. Replace the air bag diagnosis sensor unit. 5. Replace the related harness.
CURTAIN MODULE RH [VB-SHORT] [B1146]	The RH side rear curtain air bag module circuit is shorted to some power supply circuits.	
CURTAIN MODULE RH [GND-SHORT] [B1147]	The RH side rear curtain air bag module circuit is shorted to ground.	
CURTAIN MODULE RH [SHORT] [B1148]	The circuits for the RH side rear curtain air bag module are shorted to each other.	
CONTROL UNIT [B1XXX]	Air bag diagnosis sensor unit is malfunctioning.	<ol style="list-style-type: none"> 1. Visually check the wiring harness connection. 2. Replace the air bag diagnosis sensor unit.
OCCUPANT SENS C/U [UNIT FAIL] [B1017], [B1020] or [B1021]	Occupant classification system is malfunctioning.	<ol style="list-style-type: none"> 1. Replace RH front seat cushion/ occupant classification system control unit assembly.
OCCUPANT SENS C/U [COMM FAIL] [B1022]	Communication between the occupant classification system control unit and air bag diagnosis sensor unit is interrupted.	<ol style="list-style-type: none"> 1. Visually check the wiring harness connection. 2. Replace the harness if it has visible damage. 3. Replace RH front seat cushion/ occupant classification system control unit assembly. 4. Replace the air bag diagnosis sensor unit. 5. Replace the related harness.
OCCUPANT SENS [UNIT FAIL] [B1018]	Occupant classification sensor is malfunctioning.	<ol style="list-style-type: none"> 1. Replace RH front seat cushion/ occupant classification system control unit assembly.
BELT TENSION SENS [UNIT FAIL] [B1019]	Belt tension sensor is malfunctioning.	<ol style="list-style-type: none"> 1. Visually check the wiring harness connection. 2. Replace the harness if it has visible damage. 3. Replace RH front seat belt assembly. 4. Replace RH front seat cushion/ occupant classification system control unit assembly. 5. Replace the related harness.
PASS A/B INDCTR CKT [B1023]	Front passenger air bag off indicator is malfunctioning.	<ol style="list-style-type: none"> 1. Visually check the wiring harness connection. 2. Replace the harness if it has visible damage. 3. Replace front passenger air bag off indicator. 4. Replace the air bag diagnosis sensor unit. 5. Replace the related harness.

TROUBLE DIAGNOSIS

Diagnostic item	Explanation	Repair order Recheck SRS at each replacement
FRONTAL COLLISION DETECTION [B1209]	Driver and front passenger air bag modules are deployed.	1. Refer to SRS-51, "COLLISION DIAGNOSIS" .
SIDE COLLISION DETECTION [B1210]	Side or curtain air bag modules are deployed (with side air bags only).	
ROLLOVER DETECTION [B1211]	Curtain air bag module and seat belt pre-tensioner are deployed.	

NOTE:

Follow the procedures in numerical order when repairing malfunctioning parts. Confirm whether malfunction is eliminated using air bag warning lamp or CONSULT-II each time repair is finished. If malfunction is still observed, proceed to the next step. When malfunction is eliminated, further repair work is not required.

DIAGNOSTIC PROCEDURE 3

Final Check of SRS Using CONSULT-II—Diagnosis Mode

Refer to [GI-38, "CONSULT-II Start Procedure"](#) .

- If no DTC is detected on "SELF-DIAG [CURRENT]", repair of SRS is completed. Go to step 2.
If any DTC is detected on "SELF-DIAG [CURRENT]", the malfunctioning part has not been repaired completely or another malfunctioning part is being detected. Go to [SRS-23, "DIAGNOSTIC PROCEDURE 2"](#) .

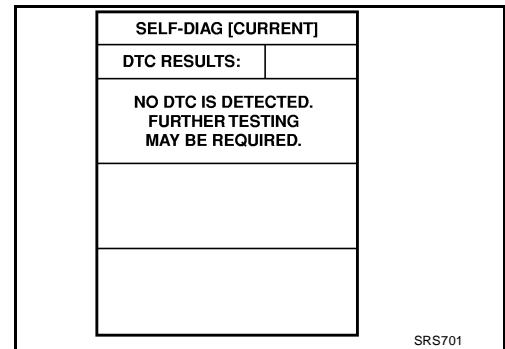

- Touch "ERASE".

NOTE:

Touch "ERASE" to clear the memory of the malfunction ("SELF-DIAG [PAST]").

If the memory of the malfunction in "SELF-DIAG [PAST]" is not erased, the User mode shows the system malfunction by the operation of the warning lamp even if the malfunction is repaired completely.

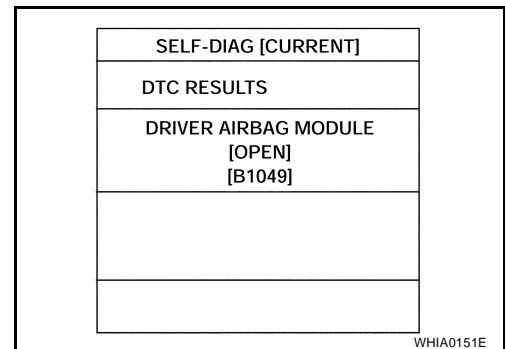

- Touch "BACK" key of CONSULT-II to "SELECT DIAG MODE" screen. Touch "SELF-DIAG [PAST]".

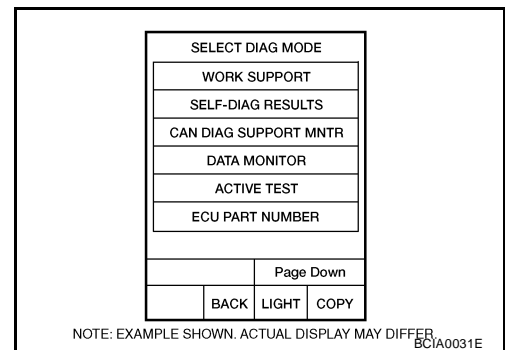

A
B
C
D
E
F
G
I
J
K
L
M

SRS

TROUBLE DIAGNOSIS

4. Check that no malfunction is detected on "SELF-DIAG [PAST]".
5. Touch "BACK" key of CONSULT-II until "SELECT SYSTEM" appears in order to return to User mode from Diagnosis mode.
6. Turn ignition switch OFF then turn off and disconnect CONSULT-II.
7. Go to [SRS-21, "DIAGNOSTIC PROCEDURE 1"](#) .

SELF-DIAG [PAST]	
DTC RESULTS:	
NO DTC IS DETECTED. FURTHER TESTING MAY BE REQUIRED.	

SRS702

DIAGNOSTIC PROCEDURE 4

Check SRS Repair History

1. CONSIDER POSSIBILITY THAT SELF-DIAGNOSTIC RESULT WAS NOT ERASED AFTER REPAIR

Check repair history of the SRS.

Have any previous repairs been made to the SRS?

- Yes >> Self-diagnostic result "SELF-DIAG [PAST]" (previously stored in the memory) might not be erased after repair. Go to [SRS-27, "DIAGNOSTIC PROCEDURE 3"](#) .
- No >> Go to [SRS-23, "DIAGNOSTIC PROCEDURE 2"](#) .

DIAGNOSTIC PROCEDURE 5

Check SRS Intermittent Malfunction Using CONSULT-II—Diagnosis Mode

Refer to [GI-38, "CONSULT-II Start Procedure"](#) .

1. If diagnostic codes are displayed on "SELF-DIAG [PAST]", go to step 4.

SELF-DIAG [PAST]	
DTC RESULTS	
DRIVER AIRBAG MODULE [OPEN] [B1049]	

WHIA0152E

If no malfunction is detected on "SELF-DIAG [PAST]", touch "BACK" and go back to "SELECT DIAG MODE".

SELF-DIAG [PAST]	
DTC RESULTS:	
NO DTC IS DETECTED. FURTHER TESTING MAY BE REQUIRED.	

SRS702

TROUBLE DIAGNOSIS

2. Touch "TROUBLE DIAG RECORD".

NOTE:

With "TROUBLE DIAG RECORD", diagnosis results previously erased by a reset operation can be displayed.

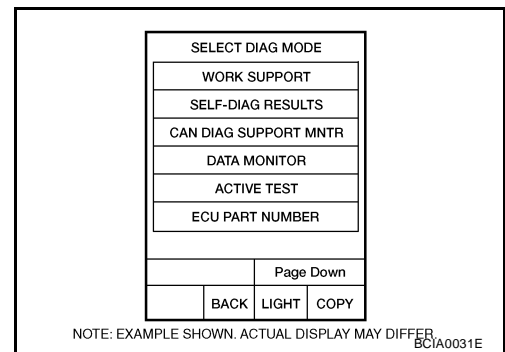

3. Diagnostic code is displayed on "TROUBLE DIAG RECORD".
4. Touch "PRINT".
5. Compare diagnostic codes to [SRS-23, "CONSULT-II Diagnostic Code Chart"](#) .
6. Touch "BACK" key of CONSULT-II until "SELECT SYSTEM" appears.
7. Turn ignition switch OFF, then turn off and disconnect CONSULT-II, and both battery cables.
8. Repair the system as outlined by the "Repair order" in "Intermittent Malfunction Diagnostic Code Chart", that corresponds to the self-diagnostic result. For replacement procedure of component parts, refer to the Removal and Installation procedure for the appropriate component.
9. Go to [SRS-27, "DIAGNOSTIC PROCEDURE 3"](#) , for final checking.

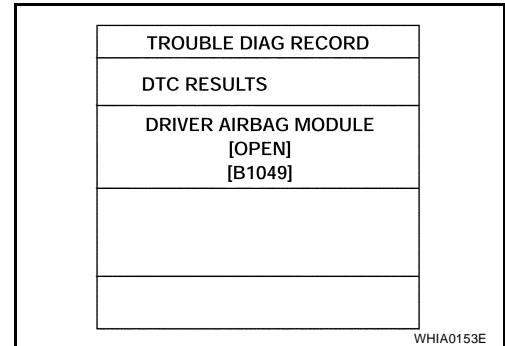

A
B
C
D
E
F
G
I
J
K
L
M

SRS

TROUBLE DIAGNOSIS

Trouble Diagnosis Without CONSULT-II

EHS00244

DIAGNOSTIC PROCEDURE 6

Inspect SRS Malfunction Using "AIR BAG" Warning Lamp—Diagnosis Mode

NOTE:

SRS will not enter Diagnosis mode if no malfunction is detected in User mode.

1. Turn ignition switch ON.
2. After "AIR BAG" warning lamp lights for 7 seconds, turn ignition switch OFF within 1 second.
3. Wait more than 3 seconds.
4. Repeat steps 1 to 3 two more times (3 times total).
5. Turn ignition switch ON.

SRS is now in Diagnosis mode.

"AIR BAG" warning lamp operates in Diagnosis mode as follows:

TROUBLE DIAGNOSIS

WARNING LAMP FLASH CODE CHART

<Diagnosis results (previously stored in the memory) might not be erased after repair or intermittent malfunctions have been detected in the past.>

Flash pattern	Repair order
<p>a through b are repeated.</p>	<p>1. Go to DIAGNOSTIC PROCEDURES 2 and 3.</p>

SHIA0026E

<Driver air bag module>	
Flash pattern	Repair order
<p>a through d are repeated. d: Two flashes indicate malfunctioning driver air bag module circuits.</p>	<ol style="list-style-type: none"> 1. Visually check the wiring harness connection. 2. Replace the harness if it has visible damage. 3. Replace the spiral cable. 4. Replace driver air bag module. 5. Replace the air bag diagnosis sensor unit. 6. Replace the related harness.

WHIA0260E

<Air bag diagnosis sensor unit>	
Flash pattern	Repair order
<p>a through d are repeated. d: Seven flashes indicate malfunctioning diagnosis sensor unit circuit.</p>	<ol style="list-style-type: none"> 1. Visually check the wiring harness connections. 2. Replace the harness if it has visible damage. 3. Replace the air bag diagnosis sensor unit. 4. Replace the related harness.

WHIA0198E

<Front passenger air bag module>	
Flash pattern	Repair order
<p>a through d are repeated. d: Eight flashes indicate malfunctioning front passenger air bag module circuit.</p>	<ol style="list-style-type: none"> 1. Visually check the wiring harness connection. 2. Replace the harness if it has visible damage. 3. Replace front passenger air bag module. 4. Replace the air bag diagnosis sensor unit. 5. Replace the related harness.

WHIA0261E

TROUBLE DIAGNOSIS

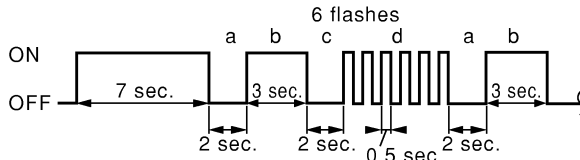
<Crash zone sensor>	
Flash pattern	Repair order
<p>a through d are repeated. d: Six flashes indicate malfunctioning crash zone sensor circuit.</p> 	<ol style="list-style-type: none"> 1. Visually check the wiring harness connection. 2. Replace the harness if it has visible damage. 3. Replace the crash zone sensor. 4. Replace the air bag diagnosis sensor unit. 5. Replace the related harness.

WHIA0200E

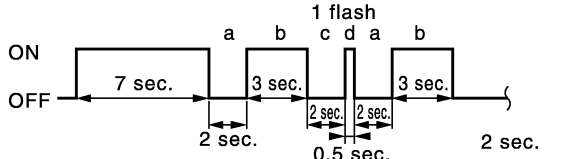
<Front RH seat belt pre-tensioner>	
Flash pattern	Repair order
<p>a through d are repeated. d: One flash indicates malfunctioning front RH seat belt pre-tensioner circuit.</p> 	<ol style="list-style-type: none"> 1. Visually check the wiring harness connections. 2. Replace the harness if it has visible damage. 3. Replace front RH seat belt pre-tensioner. 4. Replace the air bag diagnosis sensor unit. 5. Replace the related harness.

WHIA0262E

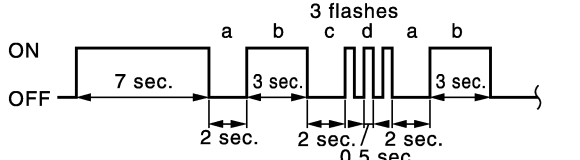
<Front LH seat belt pre-tensioner>	
Flash pattern	Repair order
<p>a through d are repeated. d: Three flashes indicate malfunctioning front LH seat belt pre-tensioner circuit.</p> 	<ol style="list-style-type: none"> 1. Visually check the wiring harness connections. 2. Replace the harness if it has visible damage. 3. Replace front LH seat belt pre-tensioner. 4. Replace the air bag diagnosis sensor unit. 5. Replace the related harness.

WHIA0263E

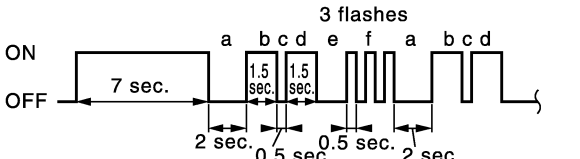
<RH side air bag (Satellite) sensor>	
Flash pattern	Repair order
<p>a through f are repeated. f: Three flashes indicate malfunctioning RH side air bag (Satellite) sensor circuit.</p> 	<ol style="list-style-type: none"> 1. Visually check the wiring harness connection. 2. Replace the harness if it has visible damage. 3. Replace the RH side air bag (Satellite) sensor. 4. Replace the air bag diagnosis sensor unit. 5. Replace the related harness.

WHIA0203E

TROUBLE DIAGNOSIS

<LH side air bag (Satellite) sensor>	
Flash pattern	Repair order
<p>a through f are repeated. f: Four flashes indicate malfunctioning LH side air bag (Satellite) sensor.</p>	<ol style="list-style-type: none"> 1. Visually check the wiring harness connection. 2. Replace the harness if it has visible damage. 3. Replace the LH side air bag (Satellite) sensor. 4. Replace the air bag diagnosis sensor unit. 5. Replace the related harness.

WHIA0204E

<Front RH side air bag module>	
Flash pattern	Repair order
<p>a through f are repeated. f: One flash indicate malfunctioning front RH side air bag module circuit.</p>	<ol style="list-style-type: none"> 1. Visually check the wiring harness connection. 2. Replace the harness if it has visible damage. 3. Replace front RH seat back assembly. 4. Replace the air bag diagnosis sensor unit. 5. Replace the related harness.

WHIA0264E

<Front LH side air bag module>	
Flash pattern	Repair order
<p>a through f are repeated. f: Two flashes indicate malfunctioning front LH side air bag module circuit.</p>	<ol style="list-style-type: none"> 1. Visually check the wiring harness connection. 2. Replace the harness if it has visible damage. 3. Replace front LH seat back assembly. 4. Replace the air bag diagnosis sensor unit. 5. Replace the related harness.

WHIA0265E

<RH side curtain air bag module>	
Flash pattern	Repair order
<p>a through f are repeated. f: Five flashes indicate malfunctioning RH side curtain air bag module circuit.</p>	<ol style="list-style-type: none"> 1. Visually check the wiring harness connection. 2. Replace the harness if it has visible damage. 3. Replace RH side curtain air bag module. 4. Replace the air bag diagnosis sensor unit. 5. Replace the related harness.

WHIA0266E

A
B
C
D
E
F
G

SRS

I
J
K
L
M

TROUBLE DIAGNOSIS

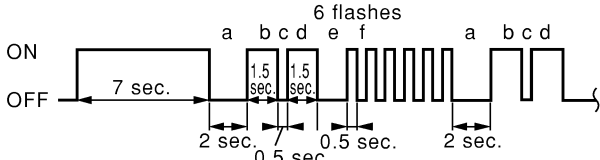
<LH side curtain air bag module>	
Flash pattern	Repair order
<p>a through f are repeated. f: Six flashes indicate malfunctioning LH side curtain air bag module circuit.</p> 	<ol style="list-style-type: none"> 1. Visually check the wiring harness connection. 2. Replace the harness if it has visible damage. 3. Replace LH side curtain air bag module. 4. Replace the air bag diagnosis sensor unit. 5. Replace the related harness.

WHIA0267E

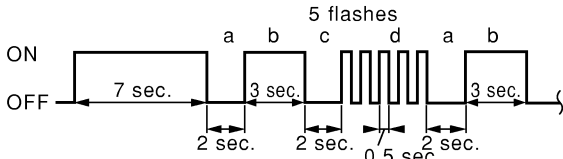
<Occupant classification system>	
Flash pattern	Repair order
<p>a through d are repeated. d: Five flashes indicate malfunctioning occupant classification system control unit.</p> 	<ol style="list-style-type: none"> 1. Visually check the wiring harness connection. 2. Replace the harness if it has visible damage. 3. Replace the RH front seat cushion occupant classification system control unit assembly. 4. Replace the air bag diagnosis sensor unit.

WHIA0211E

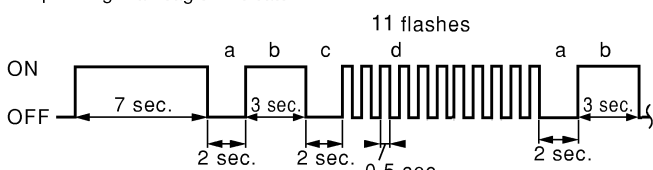
<Front passenger air bag off indicator>	
Flash pattern	Repair order
<p>a through d are repeated. d: Eleven flashes indicate malfunctioning front passenger air bag off indicator.</p> 	<ol style="list-style-type: none"> 1. Visually check the wiring harness connection. 2. Replace the harness if it has visible damage. 3. Replace front passenger air bag off indicator. 4. Replace the air bag diagnosis sensor unit. 5. Replace the related harness.

WHIA0212E

TROUBLE DIAGNOSIS

EHS00245

Trouble Diagnosis: "AIR BAG" Warning Lamp Does Not Turn Off DIAGNOSTIC PROCEDURE 7

1. CHECK CONDITION OF AIR BAG MODULE

Inspect for any deployed air bag modules or seat belt pre-tensioners.

Are any air bag modules or seat belt pre-tensioners deployed?

- YES >> Refer to [SRS-51, "COLLISION DIAGNOSIS"](#) .
- NO >> GO TO 2.

2. CHECK THE AIR BAG FUSE

Check 10A fuse [No. 13, located in the fuse block (J/B)].

Refer to [PG-4, "POWER SUPPLY ROUTING CIRCUIT"](#) .

OK or NG

- OK >> GO TO 4.
- NG >> GO TO 3.

3. CHECK AIR BAG FUSE AGAIN

Replace 10A fuse [No. 13, located in the fuse block (J/B)] and turn ignition switch ON.

Does the fuse blow again?

- YES >> Repair harness.
- NO >> Inspection End.

4. CHECK AIR BAG DIAGNOSIS SENSOR UNIT



Connect CONSULT-II and CONSULT-II CONVERTER and touch "START".

Is "AIR BAG" displayed on CONSULT-II?

- YES >> GO TO 5.
- NO >> Visually inspect the air bag diagnosis sensor unit harness connections. If the connections are OK, replace the air bag diagnosis sensor unit. Refer to [SRS-49, "Removal and Installation"](#) .

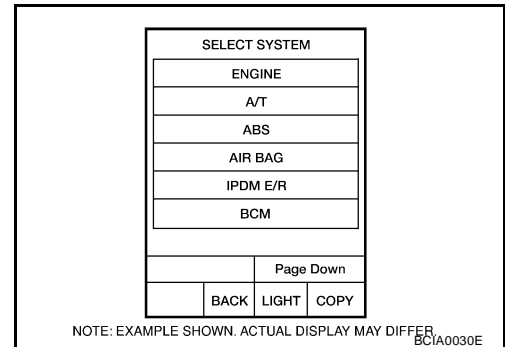

5. CHECK HARNESS CONNECTION

Check for loose connections between the combination meter and the air bag diagnosis sensor unit.

OK or NG

- OK >> Replace air bag diagnosis sensor unit. Refer to [SRS-49, "Removal and Installation"](#) .
- NG >> Properly connect the combination meter and air bag diagnosis sensor unit harness connectors. If "AIR BAG" warning lamp still does not turn off, replace the wiring harness.

TROUBLE DIAGNOSIS

Trouble Diagnosis: "AIR BAG" Warning Lamp Does Not Turn On DIAGNOSTIC PROCEDURE 8

EHS0024I

1. CHECK METER FUSE

Check the 10A fuse [No. 14, located in the fuse block (J/B)] .
Refer to [PG-4, "POWER SUPPLY ROUTING CIRCUIT"](#) .

OK or NG

OK >> GO TO 3.
NG >> GO TO 2.

2. REPLACE METER FUSE AND CHECK AGAIN

Replace 10A fuse [No. 14, located in the fuse block (J/B)] and turn ignition switch ON.

Does the fuse blow again?

Yes >> Replace harness.
No >> Inspection End.

3. CHECK HARNESS CONNECTIONS BETWEEN AIR BAG DIAGNOSIS SENSOR UNIT AND COMBINATION METER

Inspect the harness and connectors between the air bag diagnosis sensor unit and the combination meter.

Do the harness or connectors have any visible damage?

Yes >> Replace harness.
No >> GO TO 4.

4. CHECK COMBINATION METER

Disconnect the air bag diagnosis sensor unit harness connectors and turn ignition switch ON.

Does "AIR BAG" warning lamp turn on?

Yes >> Replace the air bag diagnosis sensor unit. Refer to [SRS-49, "Removal and Installation"](#) .
No >> Replace the combination meter. Refer to [IP-13, "COMBINATION METER"](#) .

DRIVER AIR BAG MODULE

- Replace the air bag module if it has been dropped or sustained an impact.
- Do not allow oil, grease or water to come in contact with the air bag module.



INSTALLATION

Installation is in the reverse order of removal.

- If driver air bag module is being replaced due to deployment, spiral cable must also be replaced. Refer to [SRS-39, "SPIRAL CABLE"](#) .
- For removal/installation of the direct-connect SRS connectors, refer to [SRS-7, "Direct-connect SRS Component Connectors"](#) .
- After the work is completed, perform self-diagnosis to check that no malfunction is detected. Refer to [SRS-21, "SRS Operation Check"](#) .

SPIRAL CABLE

PF2:25554

SPIRAL CABLE

Removal and Installation

EHS00248

SEC. 240•253•484•487

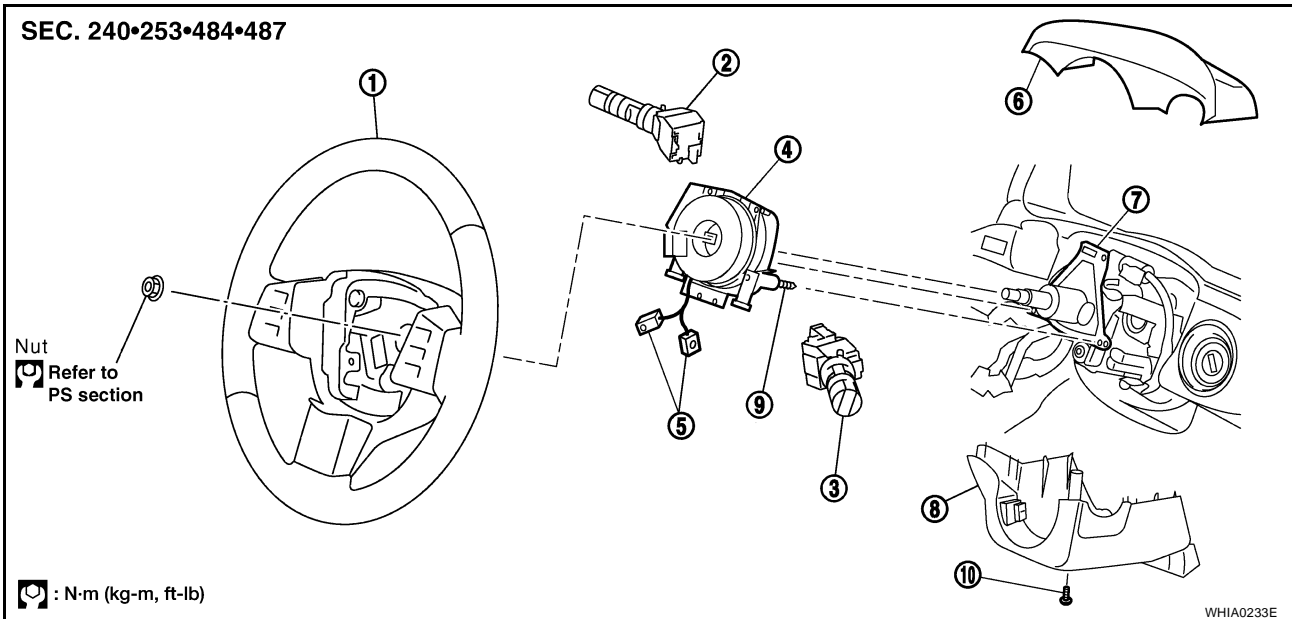

- | | | |
|--------------------|------------------------------------|----------------------------|
| 1. Steering wheel | 2. Lighting and turn signal switch | 3. Wiper and washer switch |
| 4. Spiral cable | 5. Driver air bag module connector | 6. Column cover upper |
| 7. Column assembly | 8. Column cover lower | 9. Screw (Do not remove) |
| 10. Screw | | |

REMOVAL

CAUTION:

- Before servicing the SRS, turn ignition switch OFF, disconnect both battery cables and wait at least 3 minutes.
 - When servicing the SRS, do not work from directly in front of air bag module.
1. Set the front wheels in the straight-ahead position.
 2. Remove driver air bag module. Refer to [SRS-37, "Removal and Installation"](#).
 3. Remove the steering wheel center nut.
 4. Disconnect the steering wheel switch/ horn connector from the spiral cable.
 5. Remove the steering wheel. Refer to [PS-7, "STEERING WHEEL"](#).
 6. Remove the column cover upper and lower.
 7. Remove wiper washer switch connector, then pinch the tabs at wiper and washer switch base and slide switch away from steering column to remove.

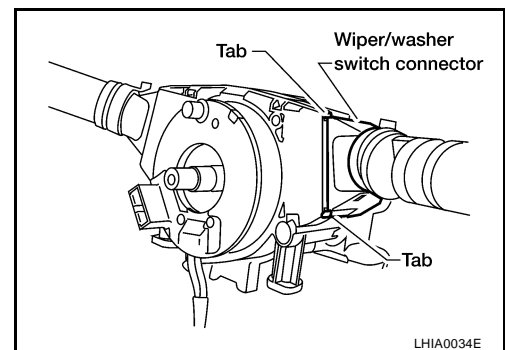

SPIRAL CABLE

8. While pressing tabs, pull lighting and turn signal switch toward driver door and disconnect from base.

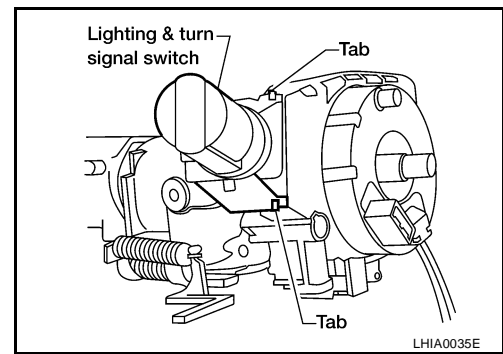

9. Remove the screws, release the clip, and remove the spiral cable.

CAUTION:

- Do not disassemble spiral cable.
- Do not apply lubricant to the spiral cable.

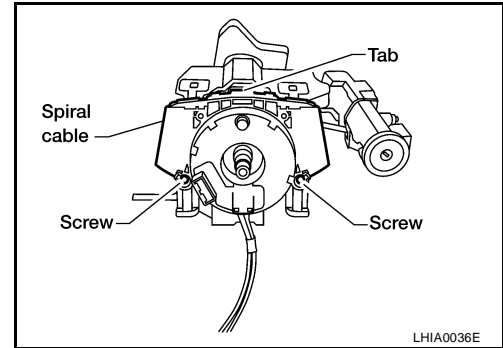

10. Remove the spiral cable connectors.

CAUTION:

With the steering linkage disconnected, the spiral cable may snap by turning the steering wheel beyond the limited number of turns. The spiral cable can be turned counterclockwise about 2.5 turns from the neutral position.

INSTALLATION

Installation is in the reverse order of removal.

- Align spiral cable correctly when installing steering wheel. Make sure that the spiral cable is in the neutral position. The neutral position is detected by turning left 2.5 revolutions from the right end position and ending with the knob at the top.
- If equipped with VDC, refer to [BRC-137, "Adjustment of Steering Angle Sensor Neutral Position"](#) for steering angle sensor adjustment.
- After the work is completed, perform self-diagnosis to make sure no malfunction is detected. Refer to [SRS-21, "SRS Operation Check"](#) .

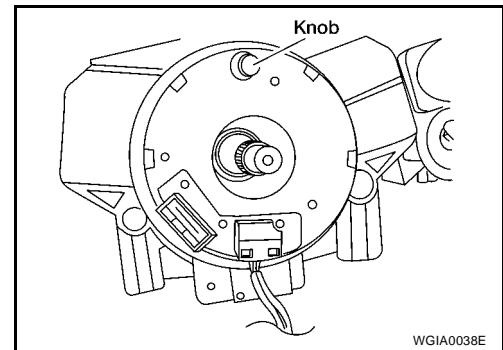

CAUTION:

- The spiral cable may snap due to steering operation if the cable is not installed in the correct position.
- With the steering linkage disconnected, the cable may snap by turning the steering wheel beyond the limited number of turns. The spiral cable can be turned counterclockwise about 2.5 turns from the neutral position.

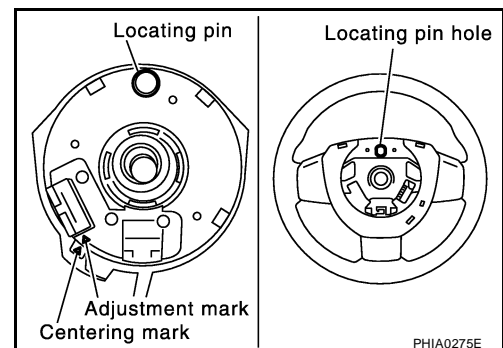

FRONT PASSENGER AIR BAG MODULE

PFM:K8515

FRONT PASSENGER AIR BAG MODULE

Removal and Installation

EHS00249

The passenger air bag module originally installed in the vehicle uses direct-connect style harness connectors. Service replacement passenger air bag modules use tab-locking style harness connectors. If the passenger air bag module is replaced or if the direct-connect harness connectors are damaged, the vehicle wiring harness must be modified to allow connection of the service replacement passenger air bag module. Refer to [SRS-42, "WIRING HARNESS MODIFICATION"](#) for wiring harness modification procedure.

REMOVAL

CAUTION:

- Do not attempt to repair or replace damaged direct-connect front passenger air bag module connectors. If a direct-connect harness connector is damaged, the front passenger air bag must be replaced and the wiring harness modified.
 - Before servicing SRS, turn the ignition switch off, disconnect both battery cables and wait at least 3 minutes.
 - Always work from the side of or under front passenger air bag module.
1. Remove the glove box. Refer to [IP-14, "LOWER INSTRUMENT PANEL RH AND GLOVE BOX"](#).
 2. Remove 2 nuts (through glove box opening) retaining front passenger air bag module to instrument panel crossmember.
 3. Disconnect the air bag module electrical connectors.
 - For removal/installation of the direct-connect SRS connectors, refer to [SRS-7, "Direct-connect SRS Component Connectors"](#).
 4. Remove the instrument panel assembly from the vehicle. Refer to [IP-10, "INSTRUMENT PANEL"](#).
 5. Remove front passenger air bag module nuts and remove air bag module from the instrument panel assembly.

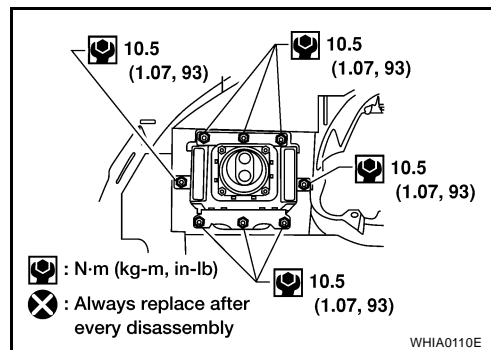

CAUTION:

- When servicing the SRS, do not work from directly in front of air bag module.
 - Always place front passenger air bag module with caution label side facing upward.
 - Do not insert any foreign objects (screwdriver, etc.) into air bag module or harness connectors.
 - Do not disassemble air bag module.
 - Do not use old nuts after removal; replace with new nuts.
 - Do not expose the front passenger air bag module to temperatures exceeding 90°C (194°F).
-
- Replace the air bag module if it has been dropped or sustained an impact.
 - Do not allow oil, grease or water to come in contact with the air bag module.
 - For removal/installation of the direct-connect SRS connectors, refer to [SRS-7, "Direct-connect SRS Component Connectors"](#).

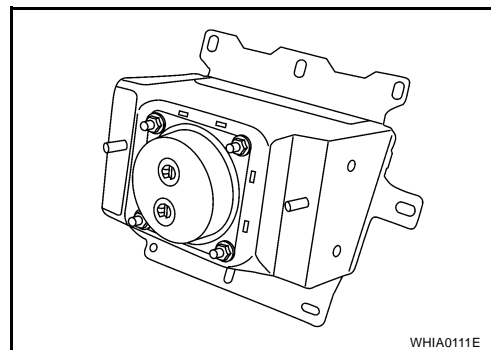

INSTALLATION

Original Passenger Air Bag Module

To install, reverse the removal procedure.

FRONT PASSENGER AIR BAG MODULE

- For removal/installation of the direct-connect SRS connectors, refer to [SRS-7, "Direct-connect SRS Component Connectors"](#) .

CAUTION:

- Always work from the side of or under front passenger air bag module.
- After the work is completed, perform self-diagnosis to check that no malfunction is detected. Refer to [SRS-21, "SRS Operation Check"](#) .

Service Replacement Passenger Air Bag Module

1. Install the front passenger air bag module to the instrument panel pad assembly.

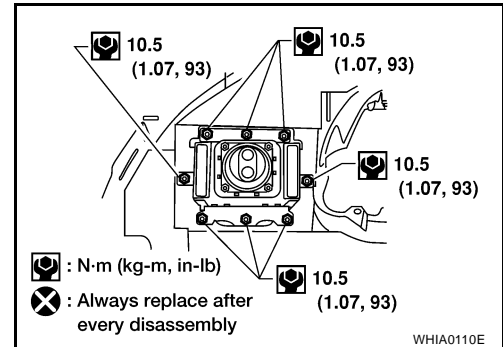

2. Install the instrument panel assembly. Refer to [IP-10, "INSTRUMENT PANEL"](#) .
3. Connect the front passenger air bag module harness connector to yellow 4-pin service replacement air bag connector and fasten connector to mounting bracket.

CAUTION:

- Always work from the side of or under front passenger air bag module.
- After the work is completed, perform self-diagnosis to check that no malfunction is detected. Refer to [SRS-21, "SRS Operation Check"](#) .

WIRING HARNESS MODIFICATION

The passenger air bag module originally installed in the vehicle uses direct-connect style harness connectors. Service replacement passenger air bag modules use tab-locking style harness connectors. If the passenger air bag module is replaced or if the direct-connect harness connectors are damaged, the vehicle wiring harness must be modified to allow connection of the service replacement passenger air bag module.

NOTE:

The wiring harness modification is to be performed only if the vehicle is equipped with the original passenger air bag which uses direct-connect harness connectors. If the passenger air bag is to be replaced in a vehicle that has already had the service replacement passenger air bag installed, the wiring harness modification is not required.

CAUTION:

- Do not attempt to repair or replace damaged direct-connect front passenger air bag module connectors. If a direct-connect harness connector is damaged, the front passenger air bag must be replaced and the wiring harness modified.
 - Before servicing SRS, turn the ignition switch off, disconnect both battery cables and wait at least 3 minutes.
 - Always work from the side of or under front passenger air bag module.
 - After the work is completed, perform self-diagnosis to check that no malfunction is detected. Refer to [SRS-21, "SRS Operation Check"](#) .
1. Locate the yellow and orange direct-connect passenger air bag module harness connectors.
 2. Use wire cutters to cut back both previously used direct-connect passenger air bag module harness connectors from the vehicle wiring harness approximately 50 mm (1.9 in) from the connectors.
 3. Remove approximately 150 mm (5.9 in) of the vehicle harness covering from the cut end.

FRONT PASSENGER AIR BAG MODULE

- Slide a piece of dual-wall heat shrink tubing (provided in the passenger air bag service kit) onto each wire of the previously used vehicle wiring harness.

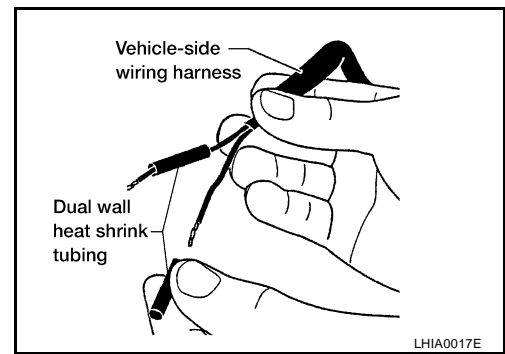

- Fold each wire back and insert into the end of the heat shrink tubing so that the end of the wire is approximately centered in the heat shrink tubing.

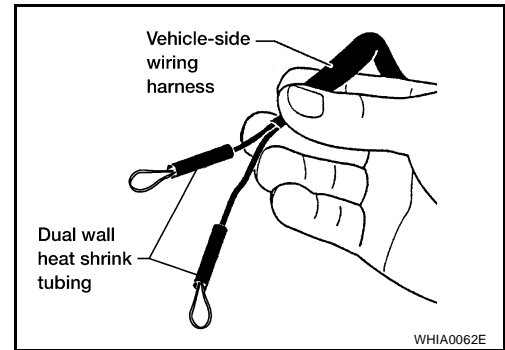

- Use a heat gun to shrink the heat shrink tubing and seal the wire.
- Use electrical tape to secure the modified circuits to the outside of the wiring harness.
- Locate the front passenger air bag service replacement connector that is taped back to the main harness. Unwrap the tape to access the yellow service replacement connector and remove the dust cover from the connector.

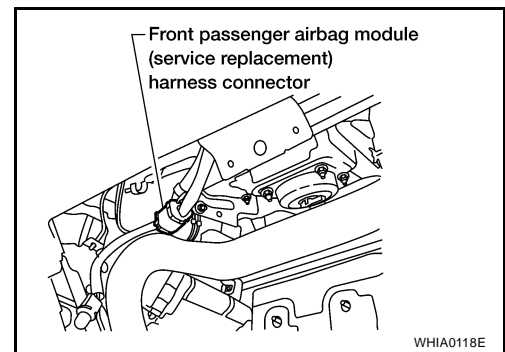

A
B
C
D
E
F
G
SRS
I
J
K
L
M

SIDE CURTAIN AIR BAG MODULE

SIDE CURTAIN AIR BAG MODULE

PPF:985P0

Removal and Installation

EHS0024A

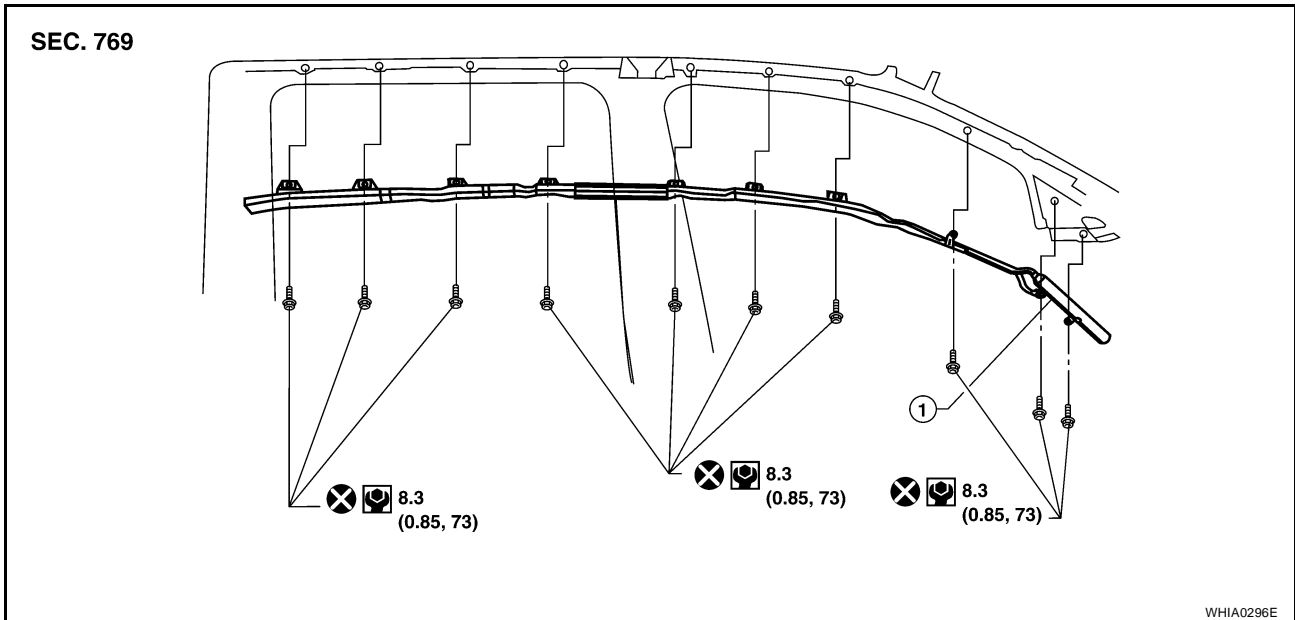

1. Side curtain air bag module connector

REMOVAL

CAUTION:

- Do not attempt to repair or replace damaged direct-connect SRS component connectors. If a direct-connect harness connector is damaged, the harness must be replaced.
 - Before servicing the SRS, turn the ignition switch off, disconnect both battery cables and wait at least 3 minutes.
 - When servicing the SRS, do not work from directly in front of air bag module.
1. Remove headlining. Refer to [EI-43, "Removal and Installation"](#).
 2. Disconnect side curtain air bag module connector.
 - For removal/installation of the direct-connect SRS connectors, refer to [SRS-7, "Direct-connect SRS Component Connectors"](#).
 3. Remove the bolts in order starting at the front or rear, and remove the side curtain air bag module.

CAUTION:

- When servicing the SRS, do not work from directly in front of air bag module.
- Do not insert any foreign objects (screwdriver, etc.) into air bag module or harness connectors.
- Do not disassemble air bag module.
- Do not expose the air bag module to temperatures exceeding 90°C (194°F).
- Replace side curtain air bag module if it has been dropped or sustained an impact.
- Do not allow oil, grease or water to come in contact with the air bag module.



INSTALLATION

Installation is in the reverse order of removal.

SIDE CURTAIN AIR BAG MODULE

- For removal/installation of the direct-connect SRS connectors, refer to [SRS-7, "Direct-connect SRS Component Connectors"](#) .
- After replacement of side curtain air bag module, perform self-diagnosis to check that no malfunction is detected. Refer to [SRS-21, "SRS Operation Check"](#) .

A

B

C

D

E

F

G

SRS

I

J

K

L

M

CRASH ZONE SENSOR

PFP:98531

EHS0024B

CRASH ZONE SENSOR

Removal and Installation REMOVAL

CAUTION:

- Before servicing the SRS, turn the ignition switch off, disconnect both battery cables and wait at least 3 minutes.
1. Remove front grille. Refer to [EI-20, "Removal and Installation"](#).
 2. Disconnect the crash zone sensor harness connector.
 3. Remove crash zone sensor nuts.

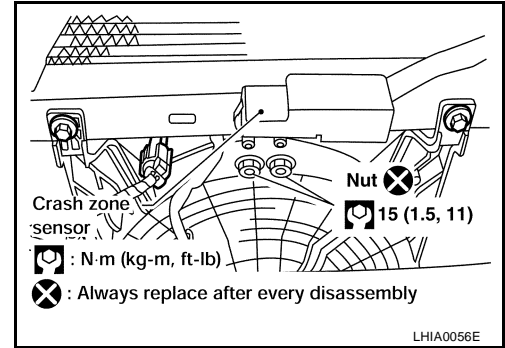

CAUTION:

- Replace crash zone sensor if it has been dropped or sustained an impact.
- Do not disassemble crash zone sensor.

INSTALLATION

Installation is in the reverse order of removal.

- After the work is complete, perform self-diagnosis to check that no malfunction is detected. Refer to [SRS-21, "SRS Operation Check"](#).

SIDE AIR BAG (SATELLITE) SENSOR

PFP:98830

SIDE AIR BAG (SATELLITE) SENSOR

Removal and Installation REMOVAL

EHS0024C

CAUTION:

- Before servicing the SRS, turn the ignition switch off, disconnect both battery cables and wait at least 3 minutes.
- 1. Remove seat belt pre-tensioner. Refer to [SB-3, "Removal and Installation of Front Seat Belt"](#) .
- 2. Remove side air bag (satellite) sensor nuts.
- 3. Disconnect the side air bag (satellite) sensor harness connector.

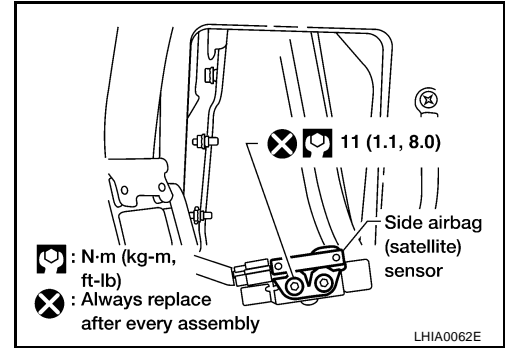

CAUTION:

- Do not use old nuts after removal; replace with new nuts.
- Check side air bag (satellite) sensor to ensure it is free of deformities, dents, cracks or rust. If it shows any visible signs of damage, replace it with new one.
- Do not disassemble side air bag (satellite) sensor.
- Replace side air bag (satellite) sensor if it has been dropped or sustained an impact.

INSTALLATION

Installation is in the reverse order of removal.

- After the work is completed, perform self-diagnosis to check that no malfunction is detected. Refer to [SRS-21, "SRS Operation Check"](#) .

A
B
C
D
E
F
G
I
J
K
L
M

SRS

FRONT SEAT BELT PRE-TENSIONER

FRONT SEAT BELT PRE-TENSIONER

PFP:86884

Removal and Installation

EHS0024D

For removal and installation procedures, refer to [SB-3, "Removal and Installation of Front Seat Belt"](#) .

DIAGNOSIS SENSOR UNIT

PFP:28556

EHS0024E

DIAGNOSIS SENSOR UNIT

Removal and Installation REMOVAL

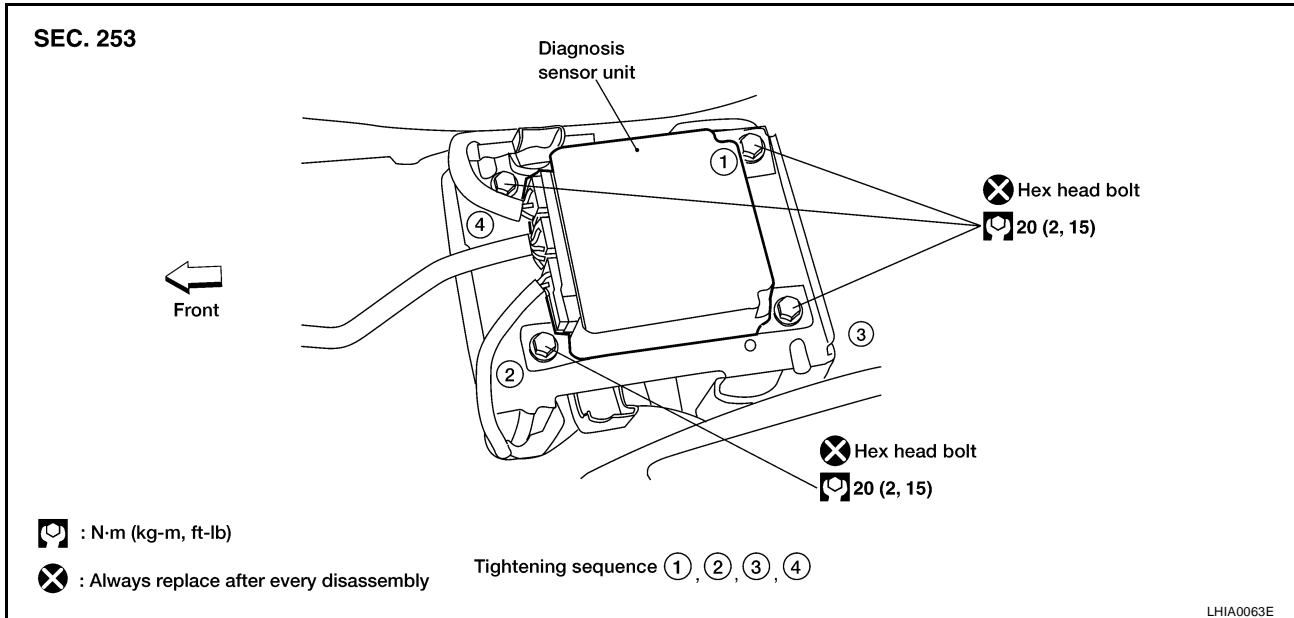

CAUTION:

- **Before servicing the SRS, turn the ignition switch off, disconnect both battery cables and wait at least 3 minutes.**
- 1. Disconnect the harness connectors for each air bag module and seat belt pre-tensioner.
- 2. Remove center console. Refer to [IP-14, "CENTER CONSOLE"](#) .
- 3. Disconnect diagnosis sensor unit harness connectors.
- 4. Remove bolts from the diagnosis sensor unit.

CAUTION:

- **Do not use old bolts; replace with new bolts.**
- **Check diagnosis sensor unit bracket to ensure it is free of deformities, dents, cracks or rust. If it shows any visible signs of damage, replace with new one.**
- **Replace diagnosis sensor unit if it has been dropped or sustained an impact.**

INSTALLATION

Installation is in the reverse order of removal.

- After the work is completed, perform self-diagnosis to check that no malfunction is detected. Refer to [SRS-21, "SRS Operation Check"](#) .

CAUTION:

- **The diagnosis sensor unit must always be installed with the arrow mark "←" pointing toward the front of the vehicle for proper operation.**

ECU DISCRIMINATED NO.

After replacing the diagnosis sensor unit, confirm that the diagnosis sensor unit identification is correct for the vehicle as equipped. Refer to [SRS-19, "CONSULT-II Function"](#) .

A
B
C
D
E
F
G

SRS

I
J
K
L
M

OCCUPANT CLASSIFICATION SYSTEM CONTROL UNIT

OCCUPANT CLASSIFICATION SYSTEM CONTROL UNIT

PF9:98852

Removal and Installation

EHS0024F

The occupant classification system control unit, occupant classification (pressure) sensor, and bladder are an integral part of the front passenger seat cushion and are replaced as an assembly. Refer to [SE-90, "REMOVAL"](#) to remove the seat, and [SE-92, "SEAT CUSHION TRIM AND PAD"](#) to replace the seat cushion.

COLLISION DIAGNOSIS

PFP:00015

EHS0024G

COLLISION DIAGNOSIS

For Frontal Collision

Check the SRS components using the following table.

- After the work is completed, perform self-diagnosis to check that no malfunction is detected. Refer to [SRS-21, "SRS Operation Check"](#).

SRS INSPECTION (FOR FRONTAL COLLISION)

Part	SRS is activated	SRS is NOT activated
Driver air bag module	If the driver air bag has deployed: REPLACE Install with new fasteners.	If the driver air bag has NOT been activated: 1. Remove driver air bag module. Check harness cover and connectors for damage, terminals for deformities, and harness for binding. 2. Install driver air bag module into the steering wheel to check fit and alignment with the wheel. 3. If no damage is found, reinstall with new fasteners. 4. If damaged— REPLACE . Install driver air bag modules with new fasteners.
Front passenger air bag module	If the front passenger air bag has deployed: REPLACE Install with new fasteners.	If the front passenger air bag has NOT been activated: 1. Remove front passenger air bag module. Check harness cover and connectors for damage, terminals for deformities, and harness for binding. 2. Install front passenger air bag module into the instrument panel to check fit with the instrument panel. 3. If no damage is found, reinstall with new fasteners. 4. If damaged— REPLACE . Install front passenger air bag modules with new fasteners.
Crash zone sensor	If any of the front air bags or seat belt pre-tensioners* have been activated: REPLACE the crash zone sensor and bracket with new fasteners. *: Confirm seat belt pre-tensioner activation using CONSULT-II only.	If the front air bags or seat belt pre-tensioners have NOT been activated: 1. Remove the crash zone sensor. Check harness connectors for damage, terminals for deformities, and harness for binding. 2. Check for visible signs of damage (dents, cracks, deformation) of the crash zone sensor and bracket. 3. Install the crash zone sensor to check fit. 4. If no damage is found, reinstall with new fasteners. 5. If damaged— REPLACE the crash zone sensor and bracket with new fasteners.
Seat belt pre-tensioner assemblies (All applicable locations: buckle, reel, lap outer)	If either the driver or passenger seat belt pre-tensioner* has been activated: REPLACE all seat belt pre-tensioner assemblies with new fasteners. *: Confirm seat belt pre-tensioner activation using CONSULT-II only.	If the pre-tensioners have NOT been activated: 1. Remove seat belt pre-tensioners. Check harness cover and connectors for damage, terminals for deformities, and harness for binding. 2. Check belts for damage and anchors for loose mounting. 3. Check retractor for smooth operation. 4. Check seat belt adjuster for damage. 5. Check for deformities of the center pillar inner. 6. If the center pillar inner has no damage, REPLACE the seat belt pre-tensioner assembly. 7. If no damage is found, reinstall seat belt pre-tensioner assembly. 8. If damaged— REPLACE . Install the seat belt pre-tensioners with new fasteners.
Diagnosis sensor unit	If any of the SRS components have been activated: REPLACE the diagnosis sensor unit. Install with new fasteners.	If none of the SRS components have been activated: 1. Check case for dents, cracks or deformities. 2. Check connectors for damage, and terminals for deformities. 3. If no damage is found, reinstall with new fasteners. 4. If damaged— REPLACE . Install diagnosis sensor unit with new fasteners.

COLLISION DIAGNOSIS

Part	SRS is activated	SRS is NOT activated
Steering wheel	<ol style="list-style-type: none"> 1. Visually check steering wheel for deformities. 2. Check harness (built into steering wheel) and connectors for damage, and terminals for deformities. 3. Install driver air bag module into the steering wheel to check fit and alignment with the wheel. 4. Check steering wheel for excessive free play. 5. If no damage is found, reinstall. 6. If damaged—REPLACE. 	
Spiral cable	If the driver front air bag has deployed: REPLACE the spiral cable.	If the driver front air bag has not deployed: <ol style="list-style-type: none"> 1. Visually check spiral cable and combination switch for damage. 2. Check connectors and protective tape for damage. 3. Check steering wheel for noise, binding or heavy operation. 4. If no damage is found, reinstall. 5. If damaged—REPLACE.
Occupant classification system (Passenger seat)	<ol style="list-style-type: none"> 1. Remove passenger seat. 2. Check control unit case for dents, cracks or deformities. 3. Check connectors and pressure sensor tube for damage, and terminals for deformities. 4. Check seat frame and cushion pan for dents or deformities. 5. If no damage is found, reinstall seat with new fasteners. 6. If damaged — REPLACE seat cushion assembly with new fasteners. 	
Harness and connectors	<ol style="list-style-type: none"> 1. Check connectors for poor connection, damage, and terminals for deformities. 2. Check harness for binding, chafing, cuts, or deformities. 3. If no damage is found, reinstall the harness and connectors. 4. If damaged—REPLACE the damaged harness. Do not attempt to repair, splice or modify any SRS harness. 	
Instrument panel	If the passenger front air bag has deployed: REPLACE the instrument panel assembly.	If the passenger front air bag has NOT deployed: <ol style="list-style-type: none"> 1. Visually check instrument panel for damage. 2. If no damage is found, reinstall the instrument panel. 3. If damaged—REPLACE the instrument panel.

For Side and Rollover Collision

EHS0024H

Check the SRS components using the following table.

- After the work is completed, perform self-diagnosis to check that no malfunction is detected. Refer to [SRS-21, "SRS Operation Check"](#).

WHEN SRS IS ACTIVATED IN THE SIDE OR ROLLOVER COLLISION

1. Replace the following components:
 - Front seat back assembly (on the side on which side air bag is activated)
 - Diagnosis sensor unit
 - (LH or RH) side air bag (satellite) sensor (on the side on which side air bag is activated)
2. Check the SRS components and the related parts using the following table.
 - Replace any SRS components and the related parts showing visible signs of damage (dents, cracks, deformation).
3. Conduct self-diagnosis using CONSULT-II and "AIR BAG" warning lamp. Refer to [SRS-21, "SRS Operation Check"](#) for details. Ensure entire SRS operates properly.

WHEN SRS IS NOT ACTIVATED IN THE SIDE OR ROLLOVER COLLISION

1. Check the SRS components and the related parts using the following table.
 - If the front seat back assembly is damaged, the front seat back assembly must be replaced.
2. Conduct self-diagnosis using CONSULT-II and "AIR BAG" warning lamp. Refer to [SRS-21, "SRS Operation Check"](#) for details. Ensure entire SRS operates properly.

COLLISION DIAGNOSIS

SRS INSPECTION (FOR SIDE AND ROLLOVER COLLISION)

Part	SRS is activated	SRS is NOT activated	A
LH side curtain air bag module	If the LH side curtain air bag has deployed: REPLACE the LH side curtain air bag module. (Repair the center pillar inner, etc. before installing new one if damaged.)	If the LH side curtain air bag has NOT deployed: 1. Check for visible signs of damage (dents, tears, deformation) of the center pillar on the collision side. 2. If damaged—Remove the LH side curtain air bag module. 3. Check for visible signs of damaged (tears etc.) of the LH side curtain air bag module. 4. Check harness and connectors for damage, and terminals for deformities. 5. If no damage is found, reinstall the LH side curtain air bag module with new fasteners. 6. If damaged—REPLACE the LH side curtain air bag module with new fasteners.	B C D
RH side curtain air bag module	If the RH side curtain air bag has deployed: REPLACE the RH side curtain air bag module. (Repair the center pillar inner, etc. before installing new one if damaged.)	If the RH side curtain air bag has NOT deployed: 1. Check for visible signs of damage (dents, tears, deformation) of the center pillar on the collision side. 2. If damaged—Remove the RH side curtain air bag module. 3. Check for visible signs of damaged (tears etc.) of the RH side curtain air bag module. 4. Check harness and connectors for damage, and terminals for deformities. 5. If no damage is found, reinstall the RH side curtain air bag module with new fasteners. 6. If damaged—REPLACE the RH side curtain air bag module with new fasteners.	E F G
Front LH side air bag module	If the front LH side air bag has deployed: REPLACE front LH seatback assembly.	If the front LH side air bag has NOT deployed: 1. Check for visible signs of damage (dents, tears, deformation) of the seat back on the collision side. 2. Check harness and connectors for damage, and terminals for deformities. 3. If damaged—REPLACE the front LH seatback assembly.	SRS I
Front RH side air bag module	If the front RH side air bag has deployed: REPLACE front RH seatback assembly.	If the front RH side air bag has NOT deployed: 1. Check for visible signs of damage (dents, tears, deformation) of the seat back on the collision side. 2. Check harness and connectors for damage, and terminals for deformities. 3. If damaged—REPLACE the front RH seatback assembly.	J K
(LH or RH) side air bag (satellite) sensor	If any of the SRS components have deployed: REPLACE the side air bag (satellite) sensor on the collision side with new fasteners. (Repair the center pillar inner, etc. before installing new one if damaged.)	If none of the SRS components have been activated: 1. Remove the side air bag (satellite) sensor on the collision side. Check harness connectors for damage, terminals for deformities, and harness for binding. 2. Check for visible signs of damage (dents, cracks, deformation) of the side air bag (satellite) sensor. 3. Install the side air bag (satellite) sensor to check fit. 4. If no damage is found, reinstall the side sir bag (satellite) sensor with new fasteners. 5. If damaged—REPLACE the side air bag (satellite) sensor with new fasteners.	L M
Diagnosis sensor unit	If any of the SRS components have deployed: REPLACE the diagnosis sensor unit with new fasteners.	If none of the SRS components have been activated: 1. Check case and bracket for dents, cracks or deformities. 2. Check connectors for damage, and terminals for deformities. 3. If no damage is found, reinstall the diagnosis sensor unit with new fasteners. 4. If damaged—REPLACE the diagnosis sensor unit with new fasteners.	

COLLISION DIAGNOSIS

Part	SRS is activated	SRS is NOT activated
Seat belt pre-tensioner assemblies (All applicable locations: buckle, reel, lap outer)	<p>If either the driver or passenger seat belt pre-tensioner* has been activated: REPLACE all seat belt pre-tensioner assemblies with new fasteners.</p> <p>*: Confirm seat belt pre-tensioner activation using CONSULT-II only.</p>	<p>If the pre-tensioners have NOT been activated:</p> <ol style="list-style-type: none"> 1. Remove seat belt pre-tensioners. Check harness cover and connectors for damage, terminals for deformities, and harness for binding. 2. Check belts for damage and anchors for loose mounting. 3. Check retractor for smooth operation. 4. Check seat belt adjuster for damage. 5. Check for deformities of the center pillar inner. 6. If the center pillar inner has no damage, REPLACE the seat belt pre-tensioner assembly. 7. If no damage is found, reinstall seat belt pre-tensioner assembly. 8. If damaged—REPLACE. Install the seat belt pre-tensioners with new fasteners.
Seat (with front side air bag)	<p>If either the front LH or front RH side air bag modules has been deployed: REPLACE front seat-back assembly on the deployed side.</p>	<p>If the front LH or front RH side air bag modules have NOT deployed:</p> <ol style="list-style-type: none"> 1. Visually check the seat on the collision side. 2. Remove the seat on the collision side and check the following for damage and deformities. <ul style="list-style-type: none"> – Harness, connectors and terminals – Frame and recliner (for front and rear seat), and also adjuster and slides (for front seat) 3. If no damage is found, reinstall the seat. 4. If damaged—REPLACE the damaged seat parts using new fasteners. If the front seat back is damaged, the front seat back assembly must be replaced.
Center inner pillar	<ol style="list-style-type: none"> 1. Check the center inner pillar on the collision side for damage (dents, cracks, deformation). 2. If damaged—REPAIR the center inner pillar. 	
Trim/headlining	<ol style="list-style-type: none"> 1. Check for visible signs of damage (dents, cracks, deformation) of the interior trim on the collision side. 2. If damaged—REPLACE the damaged trim parts. 	