

LT  
**SECTION**  
**LIGHTING SYSTEM**

A  
B  
C

**CONTENTS**

<p><b>PRECAUTIONS</b> ..... 4</p> <p>    Precautions for Supplemental Restraint System (SRS) "AIR BAG" and "SEAT BELT PRE-TENSIONER" ..... 4</p> <p>    General precautions for service operations ..... 4</p> <p><b>HEADLAMP (FOR USA)</b> ..... 5</p> <p>    Component Parts and Harness Connector Location... 5</p> <p>    System Description ..... 5</p> <p>        OUTLINE ..... 5</p> <p>        BATTERY SAVER CONTROL ..... 6</p> <p>        AUTO LIGHT OPERATION (IF EQUIPPED) ..... 6</p> <p>        VEHICLE SECURITY SYSTEM (PANIC ALARM)(IF EQUIPPED) ..... 6</p> <p>    CAN Communication System Description ..... 6</p> <p>    Schematic ..... 7</p> <p>    Wiring Diagram — H/LAMP — ..... 8</p> <p>    Terminals and Reference Values for BCM ..... 12</p> <p>    Terminals and Reference Values for IPDM E/R .... 12</p> <p>    How to Proceed With Trouble Diagnosis ..... 12</p> <p>    Preliminary Check ..... 12</p> <p>        CHECK POWER SUPPLY AND GROUND CIRCUIT TO BCM ..... 12</p> <p>        CHECK POWER SUPPLY AND GROUND CIRCUIT TO IPDM E/R ..... 12</p> <p>    CONSULT-II Function (BCM) ..... 12</p> <p>        CONSULT-II START PROCEDURE ..... 12</p> <p>        WORK SUPPORT ..... 12</p> <p>        DATA MONITOR ..... 12</p> <p>        ACTIVE TEST ..... 13</p> <p>        SELF-DIAGNOSTIC RESULTS ..... 13</p> <p>    CONSULT-II Function (IPDM E/R) ..... 13</p> <p>        CONSULT-II START PROCEDURE ..... 14</p> <p>        DATA MONITOR ..... 14</p> <p>        ACTIVE TEST ..... 14</p> <p>    Headlamp HI Does Not Illuminate (Both Sides) .... 14</p> <p>    Headlamp HI Does Not Illuminate (One Side) ..... 17</p> <p>    High Beam Indicator Lamp Does Not Illuminate ... 18</p> <p>    Headlamp LO Does Not Illuminate (Both Sides) ... 18</p> <p>    Headlamp LO Does Not Illuminate (One Side) ..... 20</p> <p>    Headlamps Do Not Turn OFF ..... 22</p>	<p>    Aiming Adjustment ..... 23</p> <p>        HEADLAMP AIMING ..... 23</p> <p>        LOW BEAM AND HIGH BEAM ..... 24</p> <p>    Bulb Replacement ..... 24</p> <p>        HEADLAMP (OUTER SIDE), FOR LOW BEAM.. 24</p> <p>        HEADLAMP (INNER SIDE), FOR HIGH BEAM.. 25</p> <p>        TURN SIGNAL/PARKING LAMP (FRONT) ..... 25</p> <p>        SIDE MARKER LAMP (FRONT) ..... 25</p> <p>    Removal and Installation ..... 25</p> <p>        COMBINATION LAMP ASSEMBLY (FRONT) .... 25</p> <p>    Disassembly and Assembly ..... 26</p> <p>        FRONT COMBINATION LAMP ASSEMBLY ..... 26</p> <p><b>HEADLAMP (FOR CANADA) - DAYTIME LIGHT SYSTEM -</b> ..... 27</p> <p>    Component Parts and Harness Connector Location.. 27</p> <p>    System Description ..... 27</p> <p>        OUTLINE ..... 28</p> <p>        DAYTIME LIGHT OPERATION ..... 28</p> <p>        COMBINATION SWITCH READING FUNCTION.. 28</p> <p>        AUTO LIGHT OPERATION (IF EQUIPPED) ..... 28</p> <p>    CAN Communication System Description ..... 28</p> <p>    Schematic ..... 29</p> <p>    Wiring Diagram — DTRL — ..... 30</p> <p>    Terminals and Reference Values for BCM ..... 34</p> <p>    How to Proceed With Trouble Diagnosis ..... 34</p> <p>    Preliminary Check ..... 34</p> <p>        CHECK BCM CONFIGURATION ..... 34</p> <p>        CHECK POWER SUPPLY AND GROUND CIRCUIT TO BCM ..... 34</p> <p>        INSPECTION PARKING BRAKE SWITCH CIRCUIT ..... 34</p> <p>    CONSULT-II Function (BCM) ..... 35</p> <p>    CONSULT-II Function (BCM) ..... 35</p> <p>    Daytime Light Control Does Not Operate Properly (Normal Headlamps Operate Properly) ..... 35</p> <p>    Aiming Adjustment ..... 36</p> <p>    Bulb Replacement ..... 36</p> <p>    Removal and Installation ..... 36</p> <p>    Disassembly and Assembly ..... 36</p> <p><b>AUTO LIGHT SYSTEM</b> ..... 37</p>
-----------------------------------------------------------------------------------------------------------------------------------------------------------------------------------------------------------------------------------------------------------------------------------------------------------------------------------------------------------------------------------------------------------------------------------------------------------------------------------------------------------------------------------------------------------------------------------------------------------------------------------------------------------------------------------------------------------------------------------------------------------------------------------------------------------------------------------------------------------------------------------------------------------------------------------------------------------------------------------------------------------------------------------------------------------------------------------------------------------------------------------------------------------------------------------------------------------------------------------------------------------------------------------------------------------------------------------------------------------------------------------------------------------------------------------------------------------------------------------------------------------------------------------------------------------------------------------------------------------------------------------------------------------------------------------------------------------------------------------------------------------------------------------------------------------------------------------------------------------------------------------------------------------------	---------------------------------------------------------------------------------------------------------------------------------------------------------------------------------------------------------------------------------------------------------------------------------------------------------------------------------------------------------------------------------------------------------------------------------------------------------------------------------------------------------------------------------------------------------------------------------------------------------------------------------------------------------------------------------------------------------------------------------------------------------------------------------------------------------------------------------------------------------------------------------------------------------------------------------------------------------------------------------------------------------------------------------------------------------------------------------------------------------------------------------------------------------------------------------------------------------------------------------------------------------------------------------------------------------------------------------------------------------------------------------------------------------------------------------------------------------------------------------------------------------------------------------------------------------------------------------------------------------------------------------------------------------------------------------------------------------------------------------------------------------------------------------------------------------------------------------------------------------------------------------------------

D  
E

F  
G

H  
I

J  
LT

L  
M

Component Parts and Harness Connector Location..	37	INSTALLATION .....	58
System Description .....	38	Removal and Installation .....	58
OUTLINE .....	38	REMOVAL .....	58
COMBINATION SWITCH READING FUNCTION..	38	INSTALLATION .....	58
EXTERIOR LAMP BATTERY SAVER CONTROL..	38	<b>TURN SIGNAL AND HAZARD WARNING LAMPS...59</b>	
DELAY TIMER FUNCTION .....	38	Component Parts and Harness Connector Location..	59
CAN Communication System Description .....	38	System Description .....	59
Major Components and Functions .....	39	OUTLINE .....	59
Schematic .....	40	TURN SIGNAL OPERATION .....	59
Wiring Diagram — AUTO/L — .....	41	HAZARD LAMP OPERATION .....	60
Terminals and Reference Values for BCM .....	44	REMOTE KEYLESS ENTRY SYSTEM OPERA-	
Terminals and Reference Values for IPDM E/R ....	44	TION .....	61
How to Proceed With Trouble Diagnosis .....	44	COMBINATION SWITCH READING FUNCTION..	61
Preliminary Check .....	44	CAN Communication System Description .....	61
SETTING CHANGE FUNCTIONS .....	44	Schematic .....	62
CHECK BCM CONFIGURATION .....	44	Wiring Diagram — TURN — .....	63
CHECK POWER SUPPLY AND GROUND CIR-		Terminals and Reference Values for BCM .....	66
CUIT TO BCM .....	44	How to Proceed With Trouble Diagnosis .....	66
CHECK POWER SUPPLY AND GROUND CIR-		Preliminary Check .....	66
CUIT TO BCM .....	44	CHECK POWER SUPPLY AND GROUND CIR-	
CONSULT-II Function (BCM) .....	44	CUIT TO BCM .....	66
CONSULT-II START PROCEDURE .....	44	CONSULT-II Function (BCM) .....	66
WORK SUPPORT .....	44	CONSULT-II START PROCEDURE .....	66
DATA MONITOR .....	45	DATA MONITOR .....	66
ACTIVE TEST .....	45	ACTIVE TEST .....	66
SELF-DIAGNOSTIC RESULTS .....	45	Turn Signals Do Not Operate .....	67
CONSULT-II Function (IPDM E/R) .....	45	Front Turn Signal Lamp Does Not Operate .....	67
CONSULT-II START PROCEDURE .....	46	Door Mirror Turn Signal Lamp Does Not Operate...68	
DATA MONITOR .....	46	Rear Turn Signal Lamp Does Not Operate .....	68
ACTIVE TEST .....	46	Hazard Warning Lamp Does Not Operate But Turn	
Trouble Diagnosis Chart by Symptom .....	46	Signal Lamp Operates .....	70
Lighting Switch Inspection .....	47	Turn Signal Indicator Lamp Does Not Operate .....	71
Optical Sensor System Inspection .....	47	Bulb Replacement .....	72
Removal and Installation .....	49	TURN SIGNAL LAMP (FRONT) .....	72
OPTICAL SENSOR .....	49	TURN SIGNAL LAMP (REAR) .....	72
<b>FRONT FOG LAMP .....</b>	<b>50</b>	Removal and Installation .....	72
Component Parts and Harness Connector Location..	50	TURN SIGNAL LAMP (FRONT) .....	72
System Description .....	50	TURN SIGNAL LAMP (REAR) .....	72
OUTLINE .....	50	<b>LIGHTING AND TURN SIGNAL SWITCH .....</b>	<b>73</b>
COMBINATION SWITCH READING FUNCTION..	51	Removal and Installation .....	73
EXTERIOR LAMP BATTERY SAVER CONTROL..	51	REMOVAL .....	73
CAN Communication System Description .....	51	INSTALLATION .....	73
Wiring Diagram — F/FOG — .....	52	<b>HAZARD SWITCH .....</b>	<b>74</b>
Terminals and Reference Values for BCM .....	54	Removal and Installation .....	74
Terminals and Reference Values for IPDM E/R ....	54	REMOVAL .....	74
How to Proceed With Trouble Diagnosis .....	54	INSTALLATION .....	74
Preliminary Check .....	54	<b>COMBINATION SWITCH .....</b>	<b>75</b>
CHECK BCM CONFIGURATION .....	54	Wiring Diagram — COMBSW — .....	75
CHECK POWER SUPPLY AND GROUND CIR-		Combination Switch Reading Function .....	76
CUIT TO BCM .....	54	CONSULT-II Function (BCM) .....	76
CHECK POWER SUPPLY AND GROUND CIR-		CONSULT-II START PROCEDURE .....	76
CUIT TO BCM .....	54	DATA MONITOR .....	76
CONSULT-II Function (BCM) .....	54	Combination Switch Inspection .....	77
CONSULT-II Function (IPDM E/R) .....	54	Removal and Installation .....	79
Front Fog Lamps Do Not Illuminate (Both Sides) ...	54	Switch Circuit Inspection .....	79
Front Fog Lamp Does Not Illuminate (One Side) ...	56	<b>STOP LAMP .....</b>	<b>80</b>
Aiming Adjustment .....	57	System Description .....	80
Bulb Replacement .....	58	Wiring Diagram — STOP/L — .....	81
REMOVAL .....	58	Bulb Replacement .....	83

HIGH-MOUNTED STOP LAMP .....	83	System Description .....	99	
STOP LAMP .....	83	TRAILER TAIL LAMP OPERATION .....	100	A
Removal and Installation .....	83	TRAILER TURN SIGNAL AND HAZARD LAMP		
HIGH-MOUNTED STOP LAMP .....	83	OPERATION .....	100	
STOP LAMP .....	83	TRAILER STOP LAMP OPERATION .....	100	B
<b>BACK-UP LAMP .....</b>	<b>84</b>	TRAILER POWER SUPPLY OPERATION .....	101	
Wiring Diagram — BACK/L — .....	84	Schematic .....	102	
Bulb Replacement .....	85	Wiring Diagram — T/TOW — .....	103	C
Removal and Installation .....	85	<b>INTERIOR ROOM LAMP .....</b>	<b>107</b>	
<b>PARKING, LICENSE PLATE AND TAIL LAMPS ....</b>	<b>86</b>	Component Parts and Harness Connector Location	107	
Component Parts and Harness Connector Location	86	System Description .....	108	D
System Description .....	86	POWER SUPPLY AND GROUND .....	108	
OPERATION BY LIGHTING SWITCH .....	86	SWITCH OPERATION .....	109	
COMBINATION SWITCH READING FUNCTION	87	ROOM LAMP TIMER OPERATION .....	110	E
EXTERIOR LAMP BATTERY SAVER CONTROL	87	INTERIOR LAMP BATTERY SAVER CONTROL	110	
CAN Communication System Description .....	87	Schematic .....	112	
Schematic .....	88	Wiring Diagram — INT/L — .....	115	F
Wiring Diagram — TAIL/L — .....	89	Terminals and Reference Values for BCM .....	123	
Terminals and Reference Values for BCM .....	92	How to Proceed With Trouble Diagnosis .....	123	
Terminals and Reference Values for IPDM E/R ....	92	Preliminary Check .....	123	
How to Proceed With Trouble Diagnosis .....	92	CHECK POWER SUPPLY AND GROUND CIR-		
Preliminary Check .....	92	CUIT TO BCM .....	123	G
CHECK POWER SUPPLY AND GROUND CIR-		CONSULT-II Function (BCM) .....	123	
CUIT TO BCM .....	92	CONSULT-II START PROCEDURE .....	123	
CHECK POWER SUPPLY AND GROUND CIR-		WORK SUPPORT .....	123	H
CUIT TO BCM .....	92	DATA MONITOR .....	123	
CONSULT-II Function (BCM) .....	92	ACTIVE TEST .....	124	
CONSULT-II Function (BCM) .....	92	Front Room/Map Lamp Assembly Control Does Not		I
Parking, License Plate and/or Tail Lamps Do Not		Operate .....	124	
Illuminate .....	92	Personal Lamp 2nd Row Control Does Not Operate		
Parking, License Plate and Tail Lamps Do Not Turn		(Room/Map Lamps Operate) .....	126	J
OFF (After Approx. 10 Minutes) .....	96	All Step/Foot/Puddle Lamps Do Not Operate .....	127	
Bulb Replacement .....	97	All Interior Room Lamps Do Not Operate .....	128	
PARKING LAMP (FRONT) .....	97	<b>ILLUMINATION .....</b>	<b>129</b>	
SIDE MARKER LAMP (FRONT) .....	97	Component Parts and Harness Connector Location	129	LT
TAIL LAMP .....	97	System Description .....	129	
Removal and Installation .....	97	ILLUMINATION OPERATION BY LIGHTING		
PARKING LAMP (FRONT) .....	97	SWITCH .....	130	L
SIDE MARKER LAMP (FRONT) .....	97	EXTERIOR LAMP BATTERY SAVER CONTROL	131	
TAIL LAMP .....	97	CAN Communication System Description .....	131	
<b>REAR COMBINATION LAMP .....</b>	<b>98</b>	Schematic .....	132	M
Bulb Replacement .....	98	Wiring Diagram — ILL — .....	135	
SIDE MARKER LAMP (REAR) .....	98	Removal and Installation .....	144	
Removal and Installation .....	98	ILLUMINATION CONTROL SWITCH .....	144	
REMOVAL .....	98	<b>BULB SPECIFICATIONS .....</b>	<b>145</b>	
INSTALLATION .....	98	Headlamp .....	145	
<b>TRAILER TOW .....</b>	<b>99</b>	Exterior Lamp .....	145	
Component Parts and Harness Connector Location	99	Interior Lamp/Illumination .....	145	

# PRECAUTIONS

## PRECAUTIONS

PF0:00011

### Precautions for Supplemental Restraint System (SRS) “AIR BAG” and “SEAT BELT PRE-TENSIONER”

EKS00A8S

The Supplemental Restraint System such as “AIR BAG” and “SEAT BELT PRE-TENSIONER”, used along with a front seat belt, helps to reduce the risk or severity of injury to the driver and front passenger for certain types of collision. This system includes seat belt switch inputs and dual stage front air bag modules. The SRS system uses the seat belt switches to determine the front air bag deployment, and may only deploy one front air bag, depending on the severity of a collision and whether the front occupants are belted or unbelted. Information necessary to service the system safely is included in the SRS and SB section of this Service Manual.

#### **WARNING:**

- To avoid rendering the SRS inoperative, which could increase the risk of personal injury or death in the event of a collision which would result in air bag inflation, all maintenance must be performed by an authorized NISSAN/INFINITI dealer.
- Improper maintenance, including incorrect removal and installation of the SRS, can lead to personal injury caused by unintentional activation of the system. For removal of Spiral Cable and Air Bag Module, see the SRS section.
- Do not use electrical test equipment on any circuit related to the SRS unless instructed to in this Service Manual. SRS wiring harnesses can be identified by yellow and/or orange harnesses or harness connectors.

### General precautions for service operations

EKS00A8T

- Never work with wet hands.
- Turn the lighting switch OFF before disconnecting and connecting the connector.
- When checking the headlamp on/off operation, check it on vehicle and with the power connected to the vehicle-side connector.
- Do not touch the headlamp bulb glass surface with bare hands or allow oil or grease to get on it. Do not touch the headlamp bulb just after the headlamp is turned off, because it is very hot.
- When the bulb has burned out, wrap it in a thick vinyl bag and discard. Do not break the bulb.
- Leaving the bulb removed from the headlamp housing for a long period of time can deteriorate the performance of the lens and reflector (dirt, clouding). Always prepare a new bulb and have it on hand when replacing the bulb.
- Do not use organic solvent (paint thinner or gasoline) to clean lamps and to remove old sealant.

# HEADLAMP (FOR USA)

## HEADLAMP (FOR USA)

PFP:26010

### Component Parts and Harness Connector Location

EKS00A8V

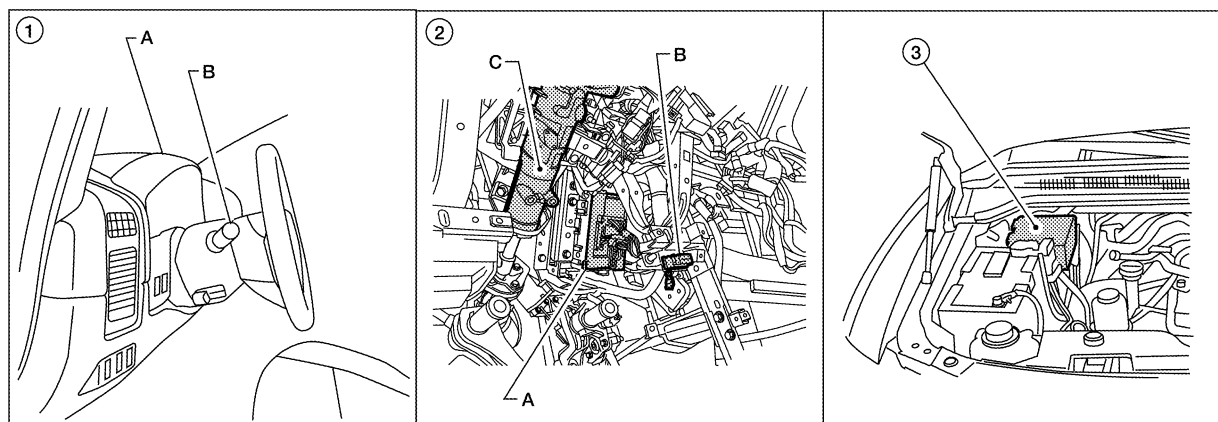

WKIA5592E

1. A. Combination meter M24  
B. Combination switch (lighting switch) M28
2. A. BCM M18 and M20 (view with instrument lower panel LH removed)  
B. Data link connector M22  
C. Steering column
3. IPDM E/R E122, E123 and E124

## System Description

EKS00A8W

Control of the headlamp system operation is dependent upon the position of the combination switch (lighting switch). When the lighting switch is placed in the 2ND position, the BCM (body control module) receives input requesting the headlamps (and tail lamps) illuminate. This input is communicated to the IPDM E/R (intelligent power distribution module engine room) across the CAN communication lines. The CPU (central processing unit) of the IPDM E/R controls the headlamp high and headlamp low relay coils. When energized, these relays direct power to the respective headlamps, which then illuminate.

## OUTLINE

Power is supplied at all times

- to ignition relay, located in the IPDM E/R,
- to headlamp high relay, located in the IPDM E/R,
- to headlamp low relay, located in the IPDM E/R,
- through 20A fuse (No. 53, located in the IPDM E/R)
- to CPU of the IPDM E/R, and
- through 50A fusible link (letter f , located in the fuse and fusible link box)
- to BCM terminal 70.

With the ignition switch in the ON or START position, power is supplied

- to ignition relay, located in the IPDM E/R, and
- through 10A fuse (No. 59, located in the fuse and relay box)
- to BCM terminal 38.

Ground is supplied

- to BCM terminal 67
- through grounds M57, M61 and M79, and
- to IPDM E/R terminals 38 and 59
- through grounds E9, E15 and E24.

A  
B  
C  
D  
E  
F  
G  
H  
I  
J  
LT  
L  
M

# HEADLAMP (FOR USA)

## Low Beam Operation

With the lighting switch in 2ND position, the BCM receives input requesting the headlamps to illuminate. This input is communicated to the IPDM E/R across the CAN communication lines. The CPU of the IPDM E/R controls the headlamp low relay coil. When energized, this relay directs power

- through 15A fuse (No. 41, located in the IPDM E/R)
- through IPDM E/R terminal 54
- to front combination lamp RH terminal 1, and
- through 15A fuse (No. 40, located in the IPDM E/R)
- through IPDM E/R terminal 52
- to front combination lamp LH terminal 1.

Ground is supplied

- to front combination lamp LH and RH terminal 4
- through grounds E9, E15 and E24.

With power and ground supplied, low beam headlamps illuminate.

## High Beam Operation/Flash-to-Pass Operation

With the lighting switch in 2ND position and placed in HIGH or PASS position, the BCM receives input requesting the headlamp high beams to illuminate. This input is communicated to the IPDM E/R across the CAN communication lines. The CPU of the combination meter controls the ON/OFF status of the HIGH BEAM indicator. The CPU of the IPDM E/R controls the headlamp high relay coil. When energized, this relay directs power

- through 10A fuse (No. 34, located in the IPDM E/R)
- through IPDM E/R terminal 56
- to front combination lamp RH terminal 2, and
- through 10A fuse (No. 35, located in the IPDM E/R)
- through IPDM E/R terminal 55
- to front combination lamp LH terminal 2.

Ground is supplied

- to front combination lamp LH and RH terminal 3
- through grounds E9, E15 and E24.

With power and ground supplied, the high beam headlamps illuminate.

## BATTERY SAVER CONTROL

When the combination switch (lighting switch) is in the 2ND position (ON), and the ignition switch is turned from ON or ACC to OFF, the battery saver control feature is activated.

Under this condition, the headlamps remain illuminated for 5 minutes, unless the combination switch (lighting switch) position is changed. If the combination switch (lighting switch) position is changed, then the headlamps are turned off.

## AUTO LIGHT OPERATION (IF EQUIPPED)

Refer to [LT-38, "System Description"](#) .

## VEHICLE SECURITY SYSTEM (PANIC ALARM)(IF EQUIPPED)

The vehicle security system (panic alarm) will flash the high beams if the system is triggered. Refer to [BL-86, "PANIC ALARM OPERATION"](#) .

## CAN Communication System Description

Refer to [LAN-2, "CAN Communication System"](#) .

EKS00A8X

# HEADLAMP (FOR USA)

## Schematic

EKS00A8Y

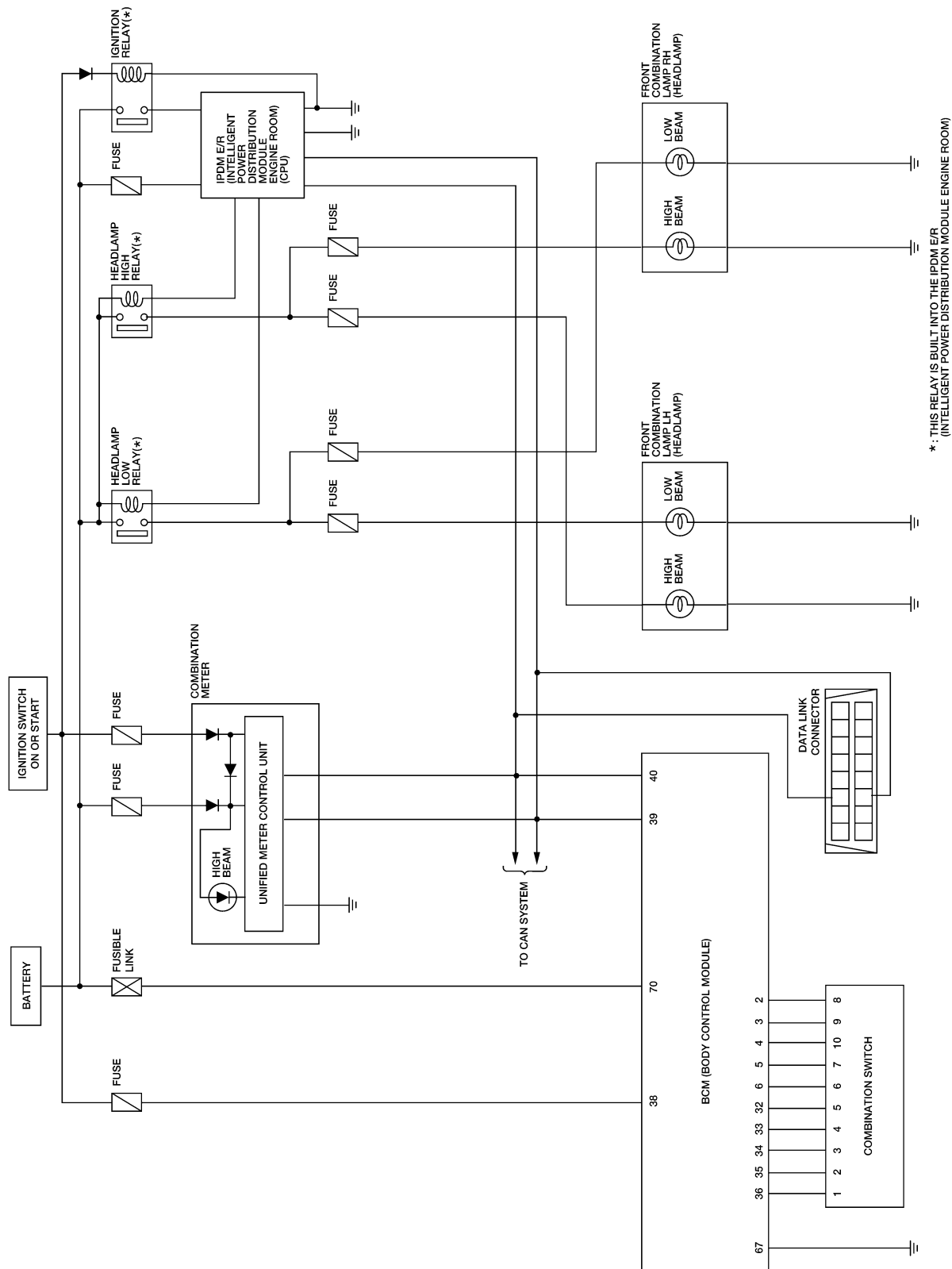

A  
B  
C  
D  
E  
F  
G  
H  
I  
J  
LT  
L  
M

WKWA3752E

# HEADLAMP (FOR USA)

## Wiring Diagram — H/LAMP —

EKS00A8Z

### LT-H/LAMP-01

▬ : DATA LINE

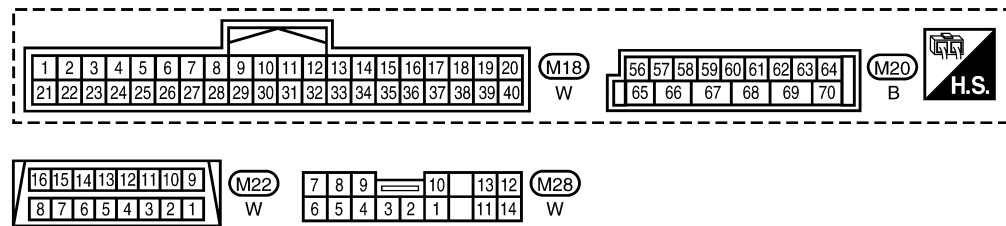
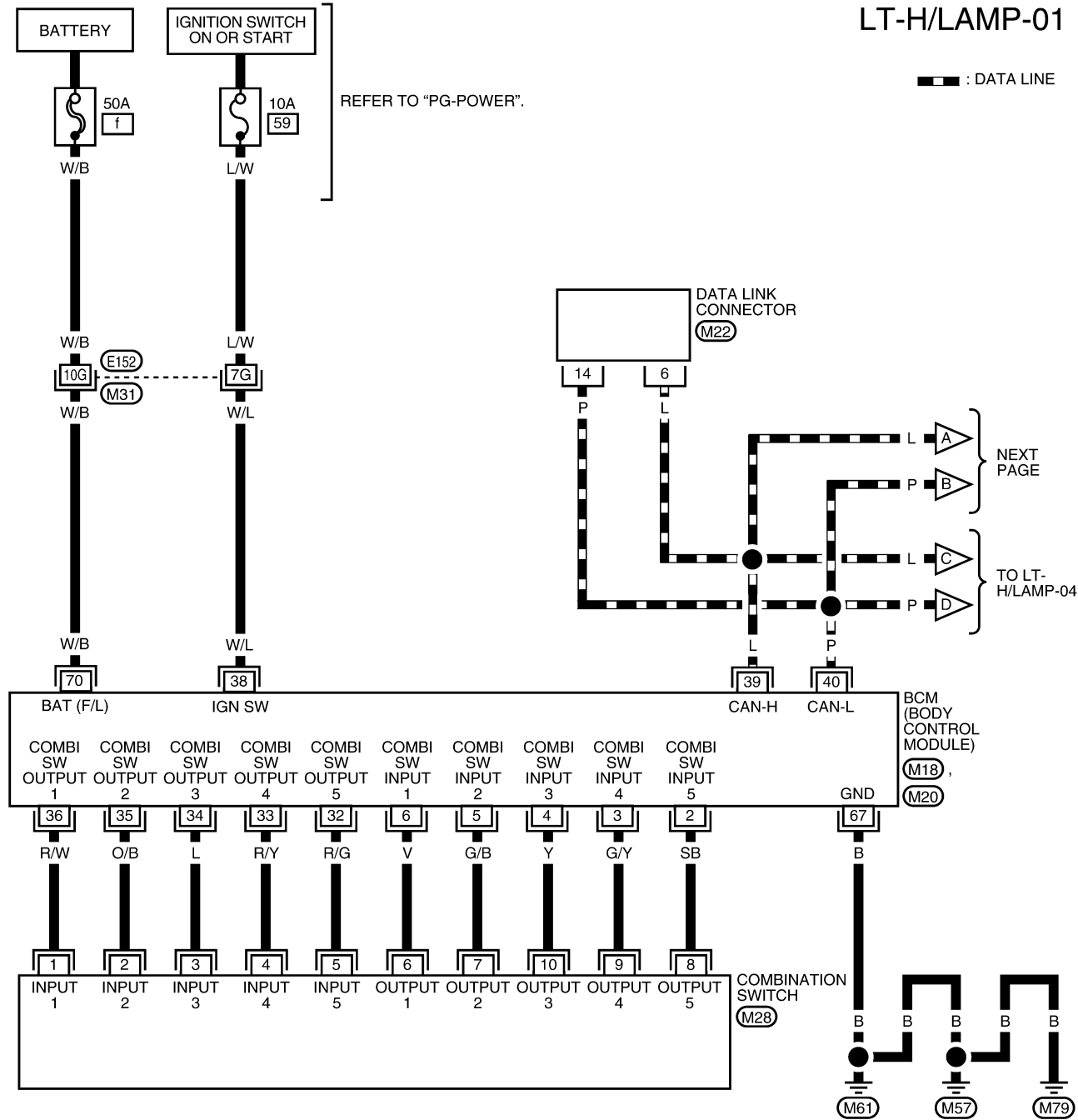

REFER TO THE FOLLOWING.  
 (M31) - SUPER MULTIPLE JUNCTION (SMJ)

WKWA3753E



# HEADLAMP (FOR USA)

LT-H/LAMP-02

▬ : DATA LINE

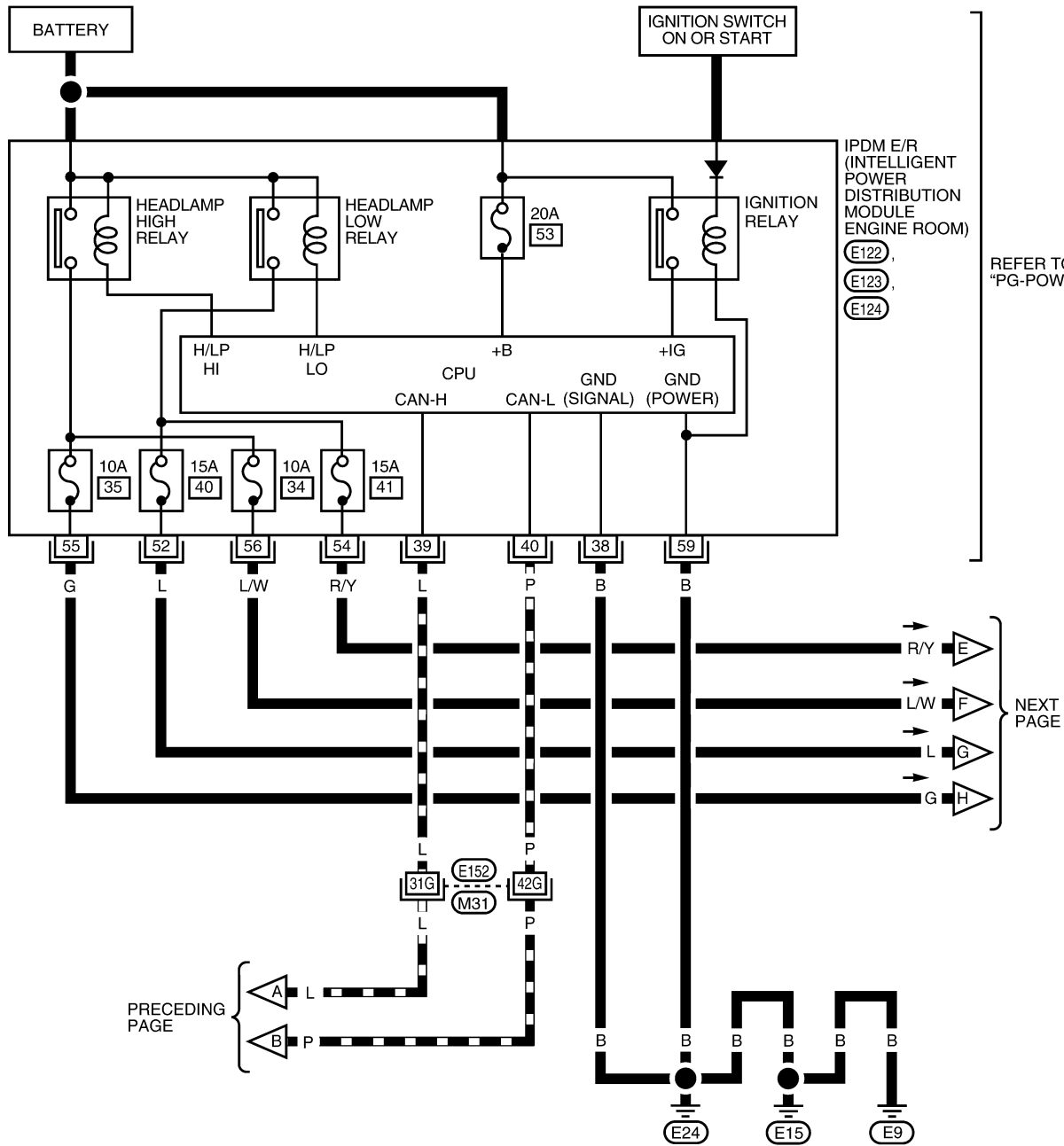

A  
B  
C  
D  
E  
F  
G  
H  
I  
J  
LT  
L  
M

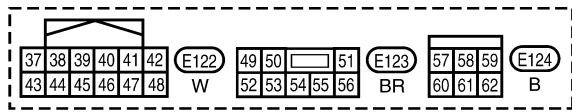

REFER TO THE FOLLOWING.  
(M31) - SUPER MULTIPLE JUNCTION (SMJ)

WKWA3754E

# HEADLAMP (FOR USA)

LT-H/LAMP-03

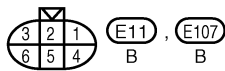
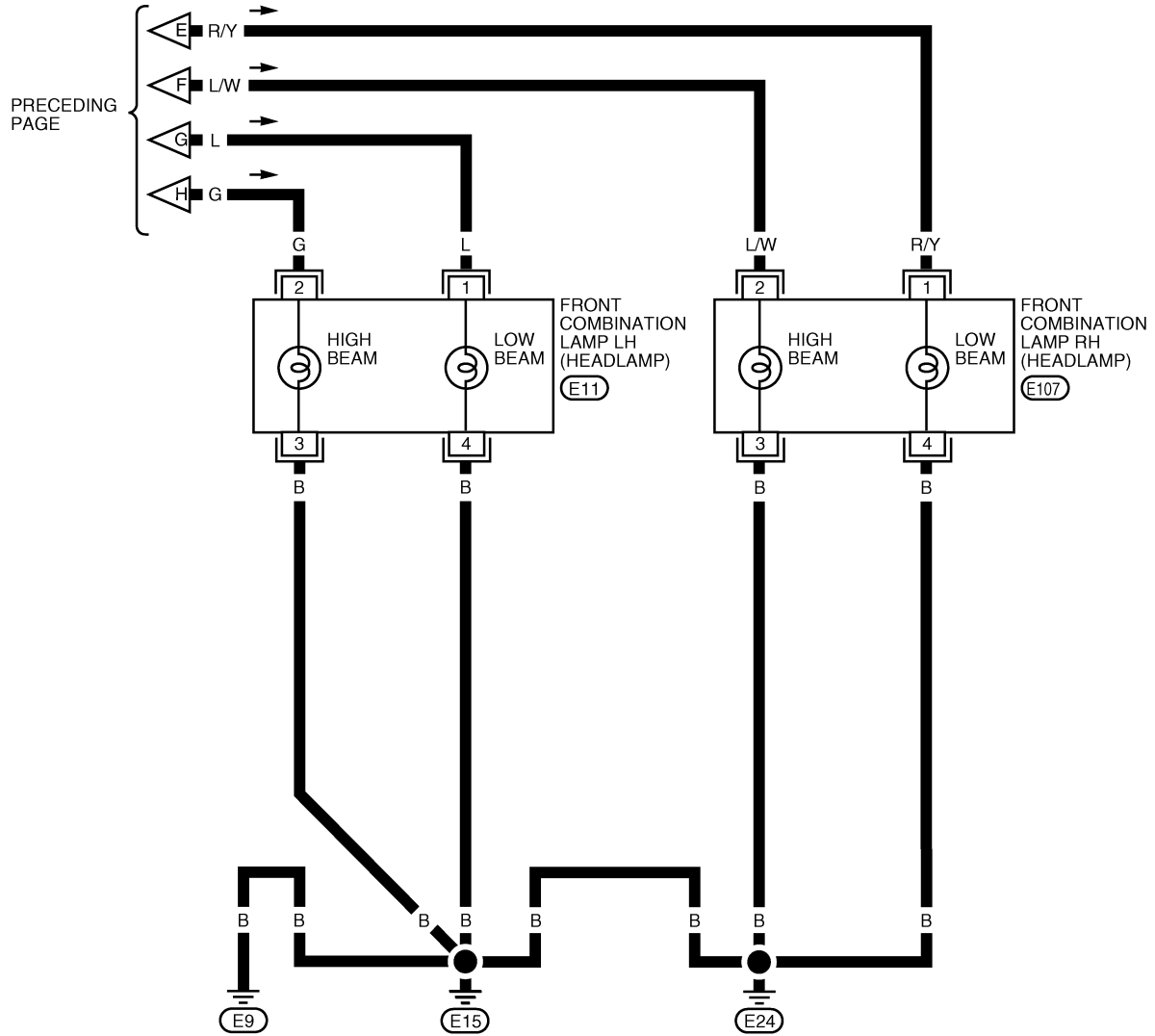

WKWA1475E

# HEADLAMP (FOR USA)

LT-H/LAMP-04

▬ : DATA LINE

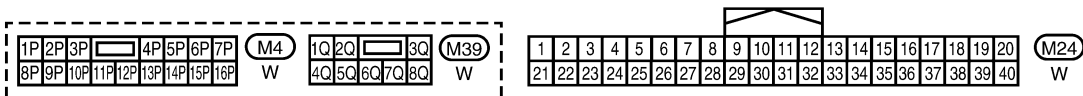
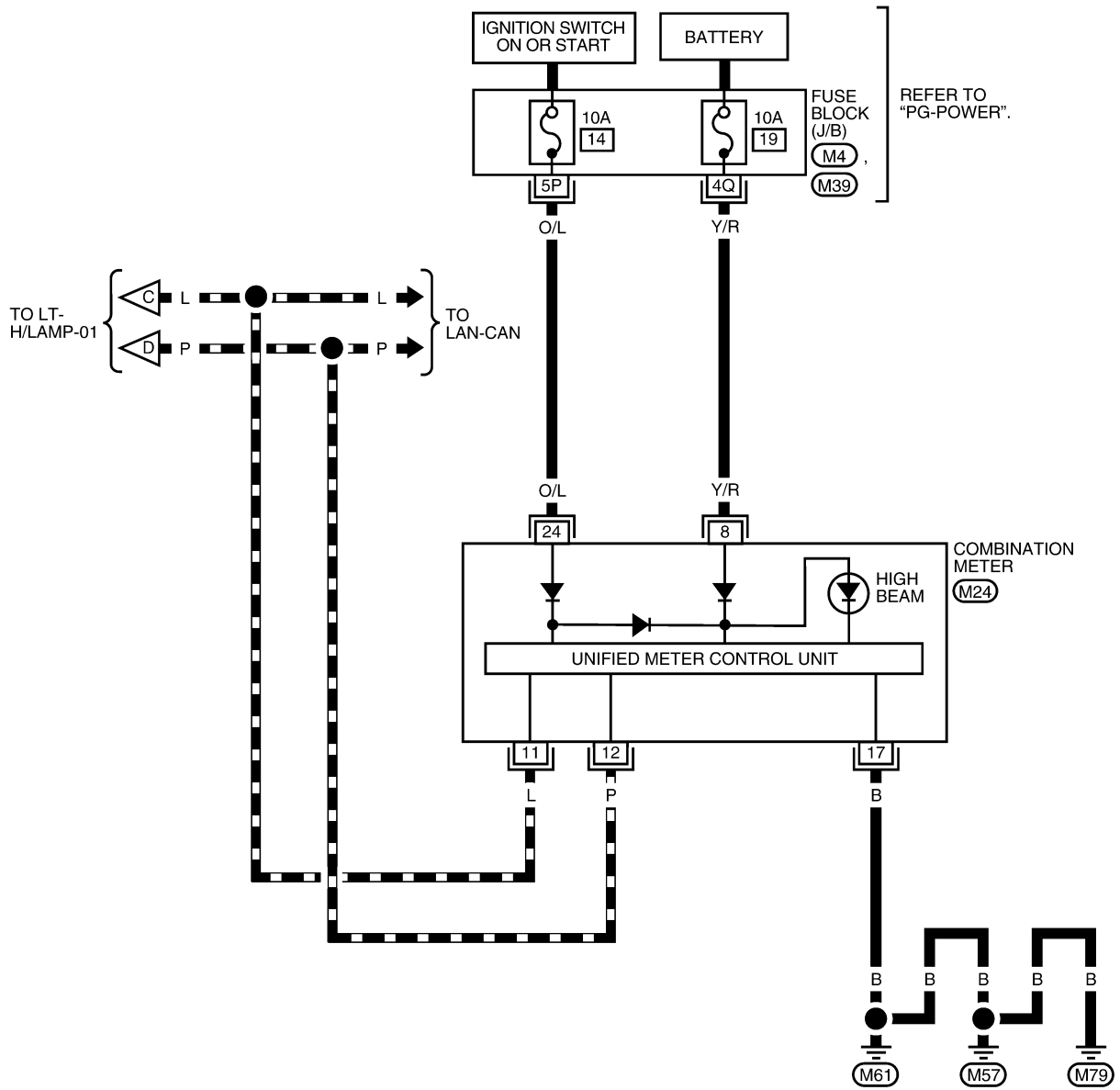

WKWA3755E

# HEADLAMP (FOR USA)

## Terminals and Reference Values for BCM

EKS00A90

Refer to [BCS-12, "Terminals and Reference Values for BCM"](#) .

## Terminals and Reference Values for IPDM E/R

EKS00A91

Refer to [PG-24, "Terminals and Reference Values for IPDM E/R"](#) .

## How to Proceed With Trouble Diagnosis

EKS00A92

1. Confirm the symptom or customer complaint.
2. Understand operation description and function description. Refer to [LT-5, "System Description"](#) .
3. Perform the Preliminary Check. Refer to [LT-12, "Preliminary Check"](#) .
4. Check symptom and repair or replace the component.
5. Does the headlamp operate normally? If YES: GO TO 6. If NO: GO TO 4.
6. Inspection End.

## Preliminary Check

EKS00A93

### CHECK POWER SUPPLY AND GROUND CIRCUIT TO BCM

Refer to [BCS-16, "BCM Power Supply and Ground Circuit Check"](#) .

### CHECK POWER SUPPLY AND GROUND CIRCUIT TO IPDM E/R

Refer to [PG-28, "IPDM E/R Power/Ground Circuit Inspection"](#) .

## CONSULT-II Function (BCM)

EKS00A94

CONSULT-II can display each diagnostic item using the diagnostic test modes shown following.

BCM diagnostic test item	Diagnostic mode	Description
Inspection by part	WORK SUPPORT	Supports inspections and adjustments. Commands are transmitted to the BCM for setting the status suitable for required operation, input/output signals are received from the BCM and received data is displayed.
	DATA MONITOR	Displays BCM input/output data in real time.
	ACTIVE TEST	Operation of electrical loads can be checked by sending drive signal to them.
	SELF-DIAG RESULTS	Displays BCM self-diagnosis results.
	CAN DIAG SUPPORT MNTR	The result of transmit/receive diagnosis of CAN communication can be read.
	ECU PART NUMBER	BCM part number can be read.
	CONFIGURATION	Performs BCM configuration read/write functions.

## CONSULT-II START PROCEDURE

Refer to [GI-38, "CONSULT-II Start Procedure"](#) .

### WORK SUPPORT

#### Display Item List

Item	Description	CONSULT-II	Factory setting
BATTERY SAVER SET	Exterior lamp battery saver control mode can be changed in this mode. Selects exterior lamp battery saver control mode between ON/OFF.	ON	×
		OFF	—

### DATA MONITOR

#### Display Item List

Monitor item	Contents
IGN ON SW	"ON/OFF" Displays "IGN position (ON)/OFF, ACC position (OFF)" judged from the ignition switch signal.
ACC ON SW	"ON/OFF" Displays "ACC (ON)/OFF, Ignition OFF (OFF)" status judged from ignition switch signal.
HI BEAM SW	"ON/OFF" Displays status (high beam switch: ON/Others: OFF) of high beam switch judged from lighting switch signal.

## HEADLAMP (FOR USA)

Monitor item	Contents
HEAD LAMP SW 1 "ON/OFF"	Displays status (headlamp switch 1: ON/Others: OFF) of headlamp switch 2 judged from lighting switch signal.
HEAD LAMP SW 2 "ON/OFF"	Displays status (headlamp switch 2: ON/Others: OFF) of headlamp switch 2 judged from lighting switch signal.
LIGHT SW 1ST "ON/OFF"	Displays status (lighting switch 1st position: ON/Others: OFF) of lighting switch judged from lighting switch signal.
AUTO LIGHT SW "ON/OFF"	Displays status of the lighting switch as judged from the lighting switch signal. (AUTO position: ON/Other than AUTO position: OFF)
PASSING SW "ON/OFF"	Displays status (flash-to-pass switch: ON/Others: OFF) of flash-to-pass switch judged from lighting switch signal.
FR FOG SW "ON/OFF"	Displays status (front fog lamp switch: ON/Others: OFF) of front fog lamp switch judged from lighting switch signal.
DOOR SW-DR "ON/OFF"	Displays status of the front door LH as judged from the front door switch LH signal. (Door is open: ON/Door is closed: OFF)
DOOR SW-AS "ON/OFF"	Displays status of the front door RH as judged from the front door switch RH signal. (Door is open: ON/Door is closed: OFF)
DOOR SW-RR "ON/OFF"	Displays status of the rear door as judged from the rear door switch (RH) signal. (Door is open: ON/Door is closed: OFF)
DOOR SW-RL "ON/OFF"	Displays status of the rear door as judged from the rear door switch (LH) signal. (Door is open: ON/Door is closed: OFF)
BACK DOOR SW "ON/OFF"	Not used.
TURN SIGNAL R "ON/OFF"	Displays status (Turn right: ON/Others: OFF) as judged from lighting switch signal.
TURN SIGNAL L "ON/OFF"	Displays status (Turn left: ON/Others: OFF) as judged from lighting switch signal.
CARGO LAMP SW "ON/OFF"	Displays status of cargo lamp switch.
OPTICAL SENSOR [0 - 5V]	Displays "ambient light (close to 5V when dark/close to 0V when light)" judged from optical sensor signal.

### ACTIVE TEST

#### Display Item List

Test item	Description
TAIL LAMP	Allows tail lamp relay to operate by switching ON-OFF.
HEAD LAMP	Allows headlamp relay (HI, LO) to operate by switching ON-OFF.
FR FOG LAMP	Allows fog lamp relay to operate by switching ON-OFF.
CARGO LAMP	Allows cargo lamp to operate by switching ON-OFF.
CORNERING LAMP	Not used.

### SELF-DIAGNOSTIC RESULTS

#### Display Item List

Monitored item	CONSULT-II display	Description
CAN communication	CAN communication [U1000]	Malfunction is detected in CAN communication.
CAN communication system	CAN communication system 1 to 6 [U1000]	Malfunction is detected in CAN system.

### CONSULT-II Function (IPDM E/R)

EKS00A95

CONSULT-II can display each diagnostic item using the diagnostic test modes shown following.

IPDM E/R diagnostic mode	Description
SELF-DIAG RESULTS	Displays IPDM E/R self-diagnosis results.
DATA MONITOR	Displays IPDM E/R input/output data in real time.
CAN DIAG SUPPORT MNTR	The result of transmit/receive diagnosis of CAN communication can be read.
ACTIVE TEST	Operation of electrical loads can be checked by sending drive signal to them.

# HEADLAMP (FOR USA)

## CONSULT-II START PROCEDURE

Refer to [GI-38, "CONSULT-II Start Procedure"](#) .

## DATA MONITOR

### All Items, Main Items, Select Item Menu

Item name	CONSULT-II screen display	Display or unit	Monitor item selection			Description
			ALL SIGNALS	MAIN SIGNALS	SELECTION FROM MENU	
Parking, license plate and tail lamps request	TAIL&CLR REQ	ON/OFF	×	×	×	Signal status input from BCM
Headlamp low beam request	HL LO REQ	ON/OFF	×	×	×	Signal status input from BCM
Headlamp high beam request	HL HI REQ	ON/OFF	×	×	×	Signal status input from BCM
Daytime lights request	DTRL REQ	ON/OFF	×	-	×	Signal status input from BCM
Front fog lamps request	FR FOG REQ	ON/OFF	×	×	×	Signal status input from BCM

### NOTE:

Perform monitoring of IPDM E/R data with the ignition switch ON. When the ignition switch is at ACC, the display may not be correct.

## ACTIVE TEST

Test item	CONSULT-II screen display	Description
Tail lamp relay output	TAIL LAMP	Allows tail lamp relay to operate by switching operation ON-OFF at your option.
Headlamp relay (HI, LO) output	LAMPS	Allows headlamp relay (HI, LO) to operate by switching operation (OFF, HI, LO) at your option (Head lamp high beam repeats ON-OFF every 1 second).
Front fog lamp relay (FOG) output		Allows fog lamp relay (FOG) to operate by switching operation ON-OFF at your option.

## Headlamp HI Does Not Illuminate (Both Sides)

EKS00A96

### 1. CHECK COMBINATION SWITCH INPUT SIGNAL

Select "BCM" on CONSULT-II. With "HEAD LAMP" data monitor, make sure "HI BEAM SW" turns ON-OFF linked with operation of lighting switch.

**When lighting switch is in HIGH position : HI BEAM SW ON**

#### OK or NG

OK >> GO TO 2.

NG >> Check lighting switch. Refer to [LT-77, "Combination Switch Inspection"](#) .

DATA MONITOR	
MONITOR	
HI BEAM SW	ON

SKIA4193E

# HEADLAMP (FOR USA)

## 2. HEADLAMP ACTIVE TEST

1. Select "IPDM E/R" on CONSULT-II, and select "ACTIVE TEST" on "SELECT DIAG MODE" screen.
2. Select "EXTERNAL LAMPS" on "SELECT TEST ITEM" screen.
3. Touch "HI" on "ACTIVE TEST" screen.
4. Make sure headlamp high beam operates.

**Headlamp high beam should operate.**

OK or NG

- OK >> GO TO 3.  
NG >> GO TO 4.

ACTIVE TEST			
EXTERNAL LAMPS		OFF	
		TAIL	
LO		HI	
FOG			
MODE	BACK	LIGHT	COPY

WKIA1438E

## 3. CHECK IPDM E/R

1. Select "IPDM E/R" on CONSULT-II, and select "DATA MONITOR" on "SELECT DIAG MODE" screen.
2. Make sure "HL LO REQ" and "HL HI REQ" turns ON when lighting switch is in HIGH position.

**When lighting switch is in HIGH position : HL LO REQ ON  
: HL HI REQ ON**

OK or NG

- OK >> Replace IPDM E/R. Refer to [PG-30, "Removal and Installation of IPDM E/R"](#) .  
NG >> Replace BCM. Refer to [BCS-26, "BCM"](#) .

DATA MONITOR			
MONITOR			
HL LO REQ	ON		
HL HI REQ	ON		
		Page Down	
		RECORD	
MODE	BACK	LIGHT	COPY

SKIA5775E

## 4. HEADLAMP HIGH FUSE INSPECTION

Inspect 10A fuse No. 34 RH and fuse No. 35 LH (located in IPDM E/R).

OK or NG

- OK >> GO TO 5.  
NG >> Check for short to ground in harness between IPDM E/R and front combination lamp. Repair as necessary.

## 5. BULB INSPECTION

Inspect inoperative headlamp bulbs.

OK or NG

- OK >> GO TO 6.  
NG >> Replace headlamp bulb. Refer to [LT-25, "HEADLAMP \(INNER SIDE\), FOR HIGH BEAM"](#) .

# HEADLAMP (FOR USA)

## 6. CHECK HEADLAMP INPUT SIGNAL

1. Turn ignition switch OFF.
2. Disconnect front combination lamp RH and LH connector.
3. Turn ignition switch ON.
4. Select "IPDM E/R" on CONSULT-II, and select "ACTIVE TEST" on "SELECT DIAG MODE" screen.
5. Select "EXTERNAL LAMPS" on "SELECT TEST ITEM" screen.
6. Touch "HI" on "ACTIVE TEST" screen.
7. When headlamp high beam is operating, check voltage between front combination lamp RH and LH harness connector and ground.

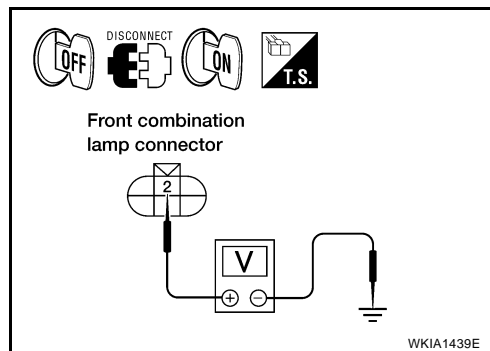

Terminals				Voltage
(+)		(-)	Ground	
Connector	Terminal			
RH	E107	2	Ground	Battery voltage
LH	E11			

OK or NG

OK >> GO TO 8.

NG >> GO TO 7.

## 7. CHECK HEADLAMP CIRCUIT

1. Turn ignition switch OFF.
2. Disconnect IPDM E/R connector.
3. Check continuity between IPDM E/R harness connector E123 terminal 56 and front combination lamp RH harness connector E107 terminal 2.

**56 - 2 : Continuity should exist.**

4. Check continuity between IPDM E/R harness connector E123 terminal 55 and front combination lamp LH harness connector E11 terminal 2.

**55 - 2 : Continuity should exist.**

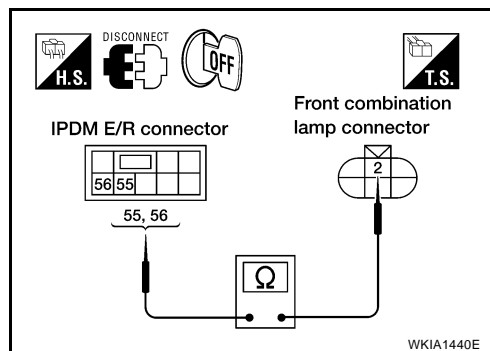

OK or NG

OK >> Replace IPDM E/R. Refer to [PG-30, "Removal and Installation of IPDM E/R"](#) .

NG >> Repair harness or connector.

## 8. CHECK HEADLAMP GROUND

1. Check continuity between front combination lamp RH harness connector E107 terminal 3 and ground.

**3 - Ground : Continuity should exist.**

2. Check continuity between front combination lamp LH harness connector E11 terminal 3 and ground.

**3 - Ground : Continuity should exist.**

OK or NG

OK >> Check front combination lamp connector for damage or poor connection. Repair as necessary.

NG >> Repair harness or connector.

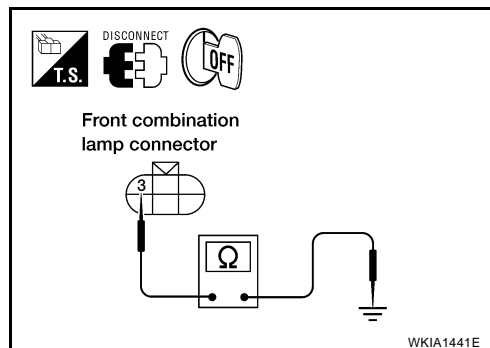



# HEADLAMP (FOR USA)

EKS00A97

## Headlamp HI Does Not Illuminate (One Side)

### 1. HEADLAMP HIGH FUSE INSPECTION

Inspect 10A fuse No. 34 RH or fuse No. 35 LH (located in IPDM E/R).

OK or NG

OK >> GO TO 2.

NG >> Check for short to ground in harness between IPDM E/R and front combination lamp. Repair as necessary.

### 2. BULB INSPECTION

Inspect inoperative headlamp bulb.

OK or NG

OK >> GO TO 3.

NG >> Replace headlamp bulb. Refer to [LT-25, "HEADLAMP \(INNER SIDE\), FOR HIGH BEAM"](#) .

### 3. CHECK POWER TO HEADLAMP

1. Disconnect inoperative front combination lamp connector.
2. Turn the high beam headlamps ON.
3. Check voltage between inoperative front combination lamp terminal and ground.

front combination lamp				Voltage (Approx.)
(+)		Terminal	(-)	
Connector				
RH	E107	2	Ground	Battery voltage
LH	E11			

OK or NG

OK >> GO TO 4.

NG >> GO TO 5.

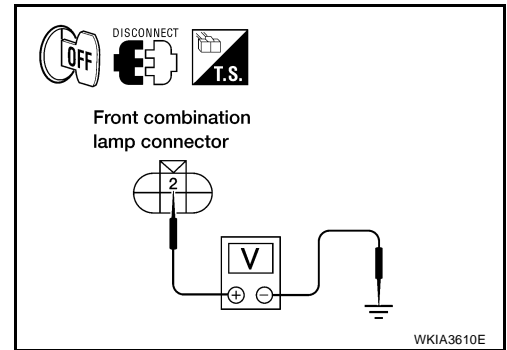

### 4. CHECK HEADLAMP GROUND

1. Turn the high beam headlamps OFF.
2. Check continuity between inoperative front combination lamp connector and ground.

front combination lamp				Continuity
Connector		Terminal		
RH	E107	3	Ground	Yes
LH	E11			

OK or NG

OK >> Check front combination lamp connector for damage or poor connection. Repair as necessary.

NG >> Repair open circuit in harness between inoperative front combination lamp and ground.

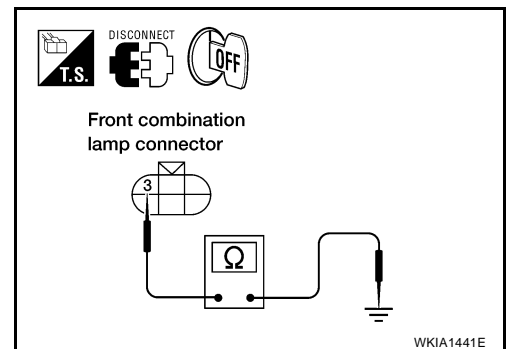

# HEADLAMP (FOR USA)

## 5. INSPECTION BETWEEN IPDM E/R AND HEADLAMPS

1. Disconnect IPDM E/R connector and inoperative front combination lamp connector.
2. Check continuity between IPDM E/R harness connector terminals and harness connector terminals of inoperative front combination lamp.

IPDM E/R		Headlamp		Continuity	
Connector	Terminal	Connector	Terminal		
E123	56	RH	E107	2	Yes
	55	LH	E11		

OK or NG

OK >> Replace IPDM E/R. Refer to [PG-30, "Removal and Installation of IPDM E/R"](#) .

NG >> Check for open circuit in harness between IPDM E/R and front combination lamp. Repair as necessary.

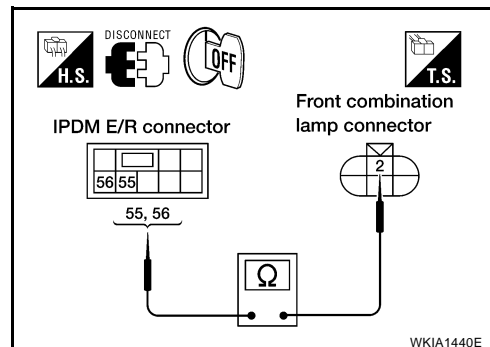

## High Beam Indicator Lamp Does Not Illuminate

EKS00A98

### 1. BULB INSPECTION

Inspect CAN communication system. Refer to [LAN-5, "TROUBLE DIAGNOSIS"](#) .

OK or NG

OK >> Replace combination meter. Refer to [IP-13, "COMBINATION METER"](#) .

NG >> Repair as necessary.

## Headlamp LO Does Not Illuminate (Both Sides)

EKS00A99

### 1. CHECK COMBINATION SWITCH INPUT SIGNAL

Select "BCM" on CONSULT-II. With "HEAD LAMP" data monitor, make sure "HEAD LAMP SW 1" and "HEAD LAMP SW 2" turns ON-OFF linked with operation of lighting switch.

**When lighting switch is in 2ND position :**  
**HEAD LAMP SW 1 ON**  
**HEAD LAMP SW 2 ON**

OK or NG

OK >> GO TO 2.

NG >> Check lighting switch. Refer to [LT-77, "Combination Switch Inspection"](#) .

DATA MONITOR	
MONITOR	
HEAD LAMP SW1	ON
HEAD LAMP SW2	ON

## 2. HEADLAMP ACTIVE TEST

1. Select "IPDM E/R" on CONSULT-II, and select "ACTIVE TEST" on "SELECT DIAG MODE" screen.
2. Select "EXTERNAL LAMPS" on "SELECT TEST ITEM" screen.
3. Touch "LO" on "ACTIVE TEST" screen.
4. Make sure headlamp low beam operates.

**Headlamp low beam should operate.**

OK or NG

OK >> GO TO 3.

NG >> GO TO 4.

ACTIVE TEST			
EXTERNAL LAMPS		OFF	
		TAIL	
LO		HI	
FOG			
MODE	BACK	LIGHT	COPY

# HEADLAMP (FOR USA)

## 3. CHECK IPDM E/R

1. Select "IPDM E/R" on CONSULT-II, and select "DATA MONITOR" on "SELECT DIAG MODE" screen.
2. Make sure "HL LO REQ" turns ON when lighting switch is in 2ND position.

**When lighting switch is in 2ND position : HL LO REQ ON**

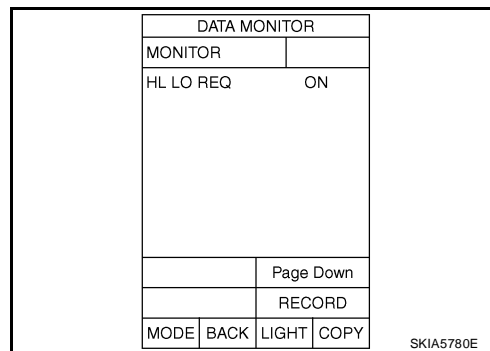

OK or NG

- OK >> Replace IPDM E/R. Refer to [PG-30, "Removal and Installation of IPDM E/R"](#) .
- NG >> Replace BCM. Refer to [BCS-26, "BCM"](#) .

## 4. HEADLAMP LOW FUSE INSPECTION

Inspect 15A fuse No. 40 LH and fuse No. 41 RH (located in IPDM E/R).

OK or NG

- OK >> GO TO 5.
- NG >> Check for short to ground in harness between IPDM E/R and front combination lamp. Repair as necessary.

## 5. BULB INSPECTION

Inspect inoperative headlamp bulbs.

OK or NG

- OK >> GO TO 6.
- NG >> Replace headlamp bulb. Refer to [LT-24, "HEADLAMP \(OUTER SIDE\), FOR LOW BEAM"](#) .

## 6. CHECK HEADLAMP INPUT SIGNAL

1. Turn ignition switch OFF.
2. Disconnect front combination lamp RH and LH connectors.
3. Turn ignition switch ON.
4. Select "IPDM E/R" on CONSULT-II, and select "ACTIVE TEST" on "SELECT DIAG MODE" screen.
5. Select "EXTERNAL LAMPS" on "SELECT TEST ITEM" screen.
6. Touch "LO" on "ACTIVE TEST" screen.
7. When headlamp low beam is operating, check voltage between front combination lamp RH and LH harness connector and ground.

(+)		Terminal	(-)	Voltage
Connector				
RH	E107	1	Ground	Battery voltage
LH	E11			

OK or NG

- OK >> GO TO 8.
- NG >> GO TO 7.

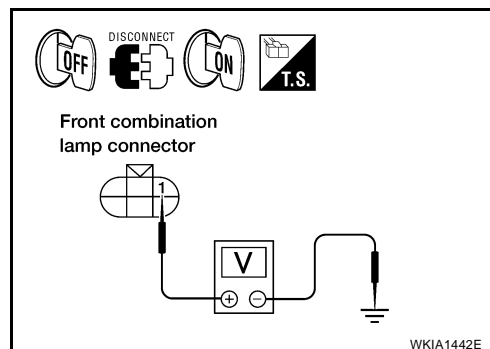

# HEADLAMP (FOR USA)

## 7. CHECK HEADLAMP CIRCUIT

1. Turn ignition switch OFF.
2. Disconnect IPDM E/R connector.
3. Check continuity between IPDM E/R harness connector E123 terminal 54 and front combination lamp RH harness connector E107 terminal 1.

**54 - 1** : Continuity should exist.

4. Check continuity between IPDM E/R harness connector E123 terminal 52 and front combination lamp LH harness connector E11 terminal 1.

**52 - 1** : Continuity should exist.

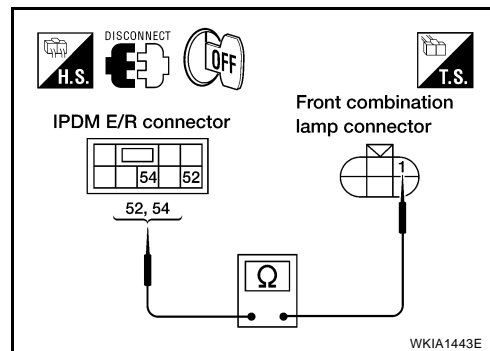

OK or NG

- OK >> Replace IPDM E/R. Refer to [PG-30, "Removal and Installation of IPDM E/R"](#) .  
NG >> Repair harness or connector.

## 8. CHECK HEADLAMP GROUND

1. Turn ignition switch OFF.
2. Check continuity between front combination lamp RH harness connector E107 terminal 4 and ground.

**4 - Ground** : Continuity should exist.

3. Check continuity between front combination lamp LH harness connector E11 terminal 4 (B) and ground.

**4 - Ground** : Continuity should exist.

OK or NG

- OK >> Check front combination lamp connector for damage or poor connection. Repair as necessary.  
NG >> Repair harness or connector.

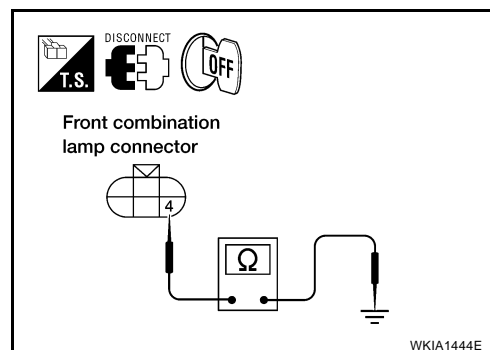

## Headlamp LO Does Not Illuminate (One Side)

EKS00A9A

### 1. HEADLAMP LOW FUSE INSPECTION

Inspect 15A fuse No. 40 LH or fuse No. 41 RH (located in IPDM E/R).

OK or NG

- OK >> GO TO 2.  
NG >> Check for short to ground in harness between IPDM E/R and front combination lamp. Repair as necessary.

### 2. BULB INSPECTION

Inspect inoperative headlamp bulb.

OK or NG

- OK >> GO TO 3.  
NG >> Replace headlamp bulb. Refer to [LT-24, "HEADLAMP \(OUTER SIDE\), FOR LOW BEAM"](#) .

# HEADLAMP (FOR USA)

## 3. CHECK POWER TO HEADLAMP

1. Disconnect inoperative front combination lamp connector.
2. Turn the low beam headlamps ON.
3. Check voltage between inoperative front combination lamp connector terminal and ground.

Terminals		Terminal	(-)	Voltage (Approx.)
(+)				
Connector	Terminal	1	Ground	Battery voltage
RH	E107			
LH	E11			

OK or NG

- OK >> GO TO 4.  
 NG >> GO TO 5.

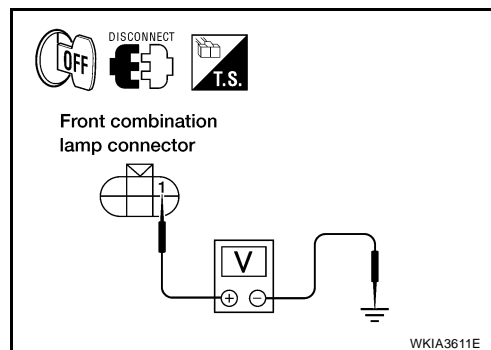

## 4. CHECK HEADLAMP GROUND

1. Turn the low beam headlamps OFF.
2. Check continuity between inoperative front combination lamp connector terminal and ground.

Terminals		Terminal	Ground	Continuity
Connector	Terminal			
RH	E107	4	Ground	Yes
LH	E11			

OK or NG

- OK >> Check front combination lamp and IPDM E/R connector. Repair as necessary.  
 NG >> Repair open circuit in harness between inoperative front combination lamp and ground.

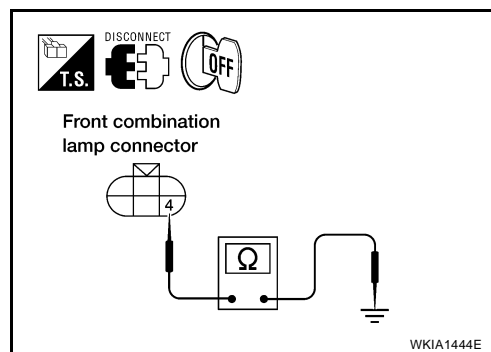

## 5. INSPECTION BETWEEN IPDM E/R AND HEADLAMPS

1. Disconnect IPDM E/R connector.
2. Check continuity between IPDM E/R harness connector terminals and harness connector terminals of inoperative front combination lamp.

IPDM E/R		Front combination lamp		Continuity
Connector	Terminal	Connector	Terminal	
E123	54	RH	E107	Yes
	52	LH	E11	

OK or NG

- OK >> Replace IPDM E/R. Refer to [PG-30, "Removal and Installation of IPDM E/R"](#) .  
 NG >> Check for open circuit in harness between IPDM E/R and headlamps. Repair as necessary.

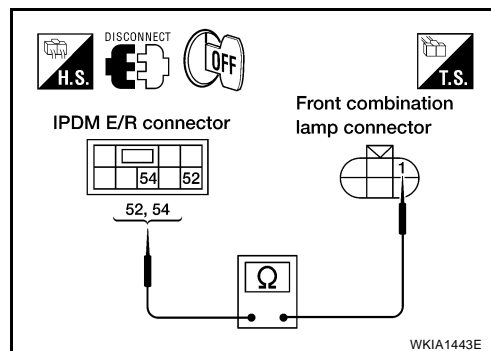

# HEADLAMP (FOR USA)

EKS00A9B

## Headlamps Do Not Turn OFF

### 1. CHECK COMBINATION SWITCH INPUT SIGNAL

Select "BCM" on CONSULT-II. With "HEAD LAMP" data monitor, make sure "HEAD LAMP SW 1" and "HEAD LAMP SW 2" turns ON-OFF linked with operation of lighting switch.

**When lighting switch is in OFF position : HEAD LAMP SW 1 OFF  
: HEAD LAMP SW 2 OFF**

OK or NG

OK >> Replace IPDM E/R. Refer to [PG-30, "Removal and Installation of IPDM E/R"](#) .

NG >> GO TO 2.

DATA MONITOR	
MONITOR	
HEAD LAMP SW 1	OFF
HEAD LAMP SW 2	OFF

SKIA5200E

### 2. CHECK LIGHTING SWITCH

Check lighting switch. Refer to [LT-77, "Combination Switch Inspection"](#) .

OK or NG

OK >> GO TO 3.

NG >> Replace lighting switch. Refer to [LT-79, "Removal and Installation"](#) .

### 3. CHECKING CAN COMMUNICATIONS BETWEEN BCM AND IPDM E/R

Select "BCM" on CONSULT-II and perform self-diagnosis for BCM.

Display of self-diagnosis results

NO DTC>> Replace IPDM E/R. Refer to [PG-30, "Removal and Installation of IPDM E/R"](#) .

CAN COMM CIRCUIT>> Refer to [LAN-5, "TROUBLE DIAGNOSIS"](#) .

SELF-DIAG RESULTS			
DTC RESULTS		TIME	
CAN COMM CIRCUIT [U1000]		PAST	
ERASE		PRINT	
MODE	BACK	LIGHT	COPY

SKIA1039E

# HEADLAMP (FOR USA)

## Aiming Adjustment

EKS00GFS

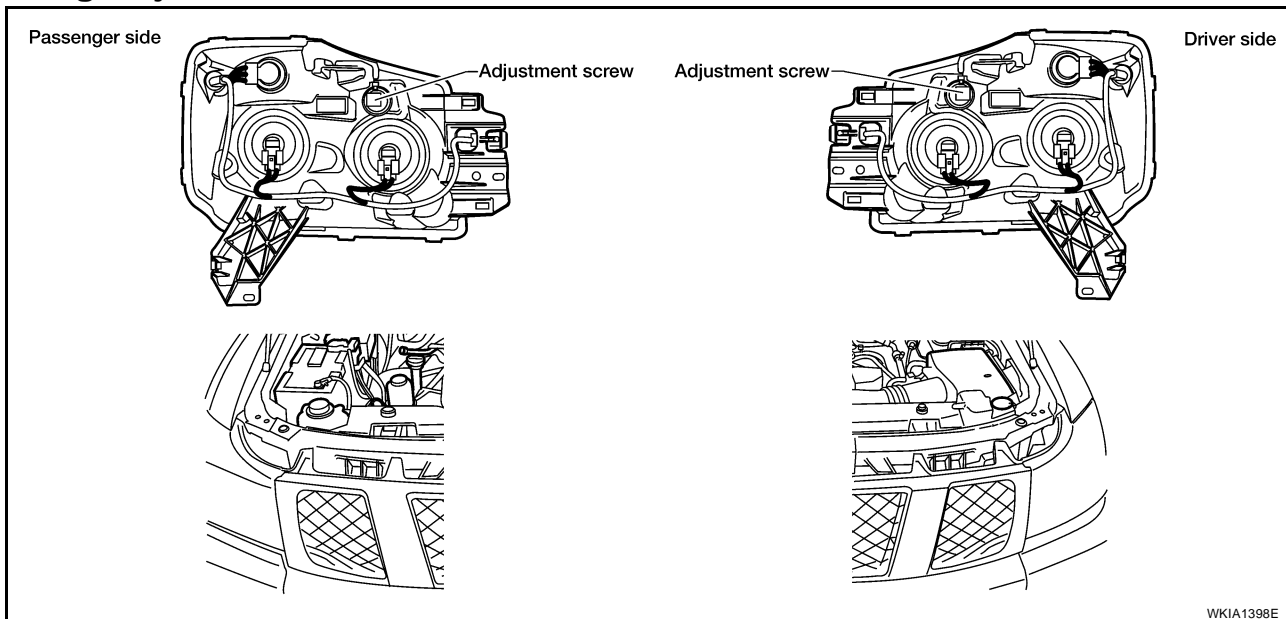

### NOTE:

- For details, refer to the regulations in your area.
- If vehicle front body has been repaired and /or the headlamp assembly has been replaced, check headlamp aiming.

## HEADLAMP AIMING

### NOTE:

- Before performing aiming adjustment, check the following:
  - Confirm headlamp aiming switch is set to "0" (zero) position (if equipped).
  - Ensure all tires are inflated to correct pressure.
  - Place vehicle and screen on level surface.
  - Ensure there is no load in vehicle other than the driver (or equivalent weight placed in driver's position). Coolant and engine oil filled to correct level, and fuel tank full.
  - Confirm spare tire, jack and tools are properly stowed.
  - Aim each headlamp individually and ensure other headlamp beam pattern is blocked from screen.
  - Use adjusting screw to perform aiming adjustment.

A  
B  
C  
D  
E  
F  
G  
H  
I  
J  
LT  
L  
M

# HEADLAMP (FOR USA)

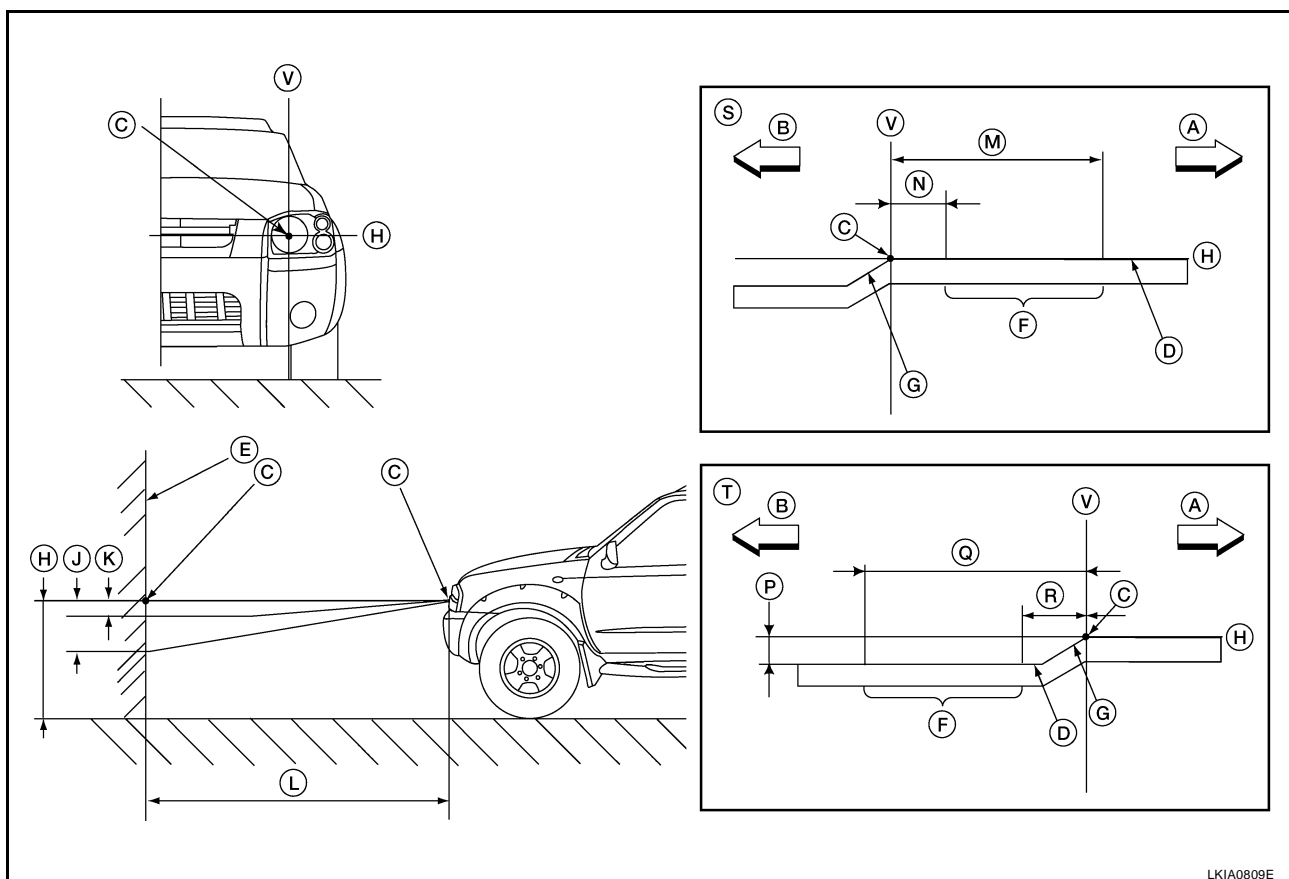

LKIA0809E

- |                      |                                       |                                        |
|----------------------|---------------------------------------|----------------------------------------|
| A. Right             | B. Left                               | C. Center of headlamp bulb (H-V point) |
| D. Cutoff line       | E. Screen                             | F. Aim evaluation segment              |
| G. Step              | H. Horizontal center line of headlamp | J. 103 mm (4.06 in.)                   |
| K. 37 mm (1.46 in.)  | L. 7.62 m (25 ft.)                    | M. 399 mm (15.71 in.)                  |
| N. 133 mm (5.24 in.) | P. 53.2 mm (2.09 in.)                 | Q. 466 mm (18.35 in.)                  |
| R. 200 mm (7.87 in.) | S. RH headlamp aiming screen          | T. LH headlamp aiming screen           |

## NOTE:

Basic illuminating area for adjustment should be within the range shown on the aiming chart. Adjust headlamps accordingly.

## LOW BEAM AND HIGH BEAM

1. Turn headlamp low beam on.
2. Use adjusting screw to perform aiming adjustment.

## Bulb Replacement

EKS00GFT

### CAUTION:

- Turn headlamp switch OFF before disconnecting headlamp harness connector.
- Do not touch bulb by hand right after being turned off. Burning may result.
- Do not touch the glass of bulb directly by hand. Keep grease and other oily substances away from it.
- Do not leave bulb out of front combination lamp assembly for a long time because dust, moisture, smoke, etc. may affect the performance of the lamp. When replacing headlamp bulb, be sure to replace it with a new one.

## HEADLAMP (OUTER SIDE), FOR LOW BEAM

### Removal

1. Position fender protector aside.
2. Turn headlamp switch OFF.
3. Disconnect headlamp electrical connector.



## HEADLAMP (FOR USA)

4. Turn the bulb socket counterclockwise and remove bulb .

### Installation

Installation is in the reverse order of removal.

### HEADLAMP (INNER SIDE), FOR HIGH BEAM

#### Removal

1. Turn headlamp switch OFF.
2. Disconnect headlamp electrical connector.
3. Turn the bulb socket counterclockwise and remove bulb.

#### Installation

Installation is in the reverse order of removal.

### TURN SIGNAL/PARKING LAMP (FRONT)

#### NOTE:

Reach through wheel opening for access.

#### Removal

1. Turn the bulb socket counterclockwise to unlock.
2. Pull the bulb to remove from the socket.

#### Installation

Installation is in the reverse order of removal.

### SIDE MARKER LAMP (FRONT)

#### Removal

#### NOTE:

Reach through wheel opening for access.

1. Turn the side marker lamp (front) bulb socket counterclockwise and remove side marker lamp (front) bulb socket.
2. Pull to remove side marker lamp (front) from the side marker lamp (front) bulb socket.

#### Installation

Installation is in the reverse order of removal.

### Removal and Installation COMBINATION LAMP ASSEMBLY (FRONT)

#### CAUTION:

- Turn headlamp switch OFF before disconnecting headlamp harness connector.
- Do not touch bulb by hand right after being turned off. Burning may result.
- Do not touch the glass of bulb directly by hand. Keep grease and other oily substances away from it.
- Do not leave bulb out of combination lamp assembly (front) for a long time because dust, moisture, smoke, etc. may affect the performance of the lamp. When replacing bulb, be sure to replace it with a new one.

#### Removal

1. Disconnect combination lamp assembly (front).
2. Remove front fascia. Refer to [EI-14, "FRONT BUMPER"](#) .

A

B

C

D

E

F

G

H

I

J

LT

EKS00GFU

L

M

## HEADLAMP (FOR USA)

3. Remove combination lamp assembly (front) bolts.
4. Remove combination lamp (front) assembly.

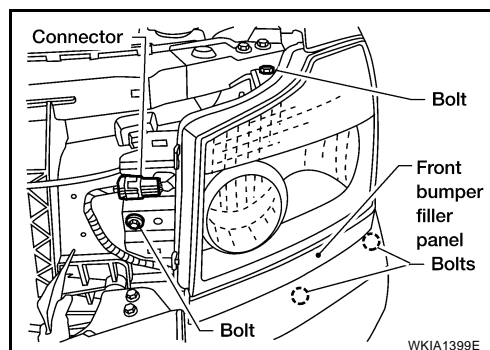

### Installation

Installation is in the reverse order of removal.

### Disassembly and Assembly FRONT COMBINATION LAMP ASSEMBLY

EKS00GFV

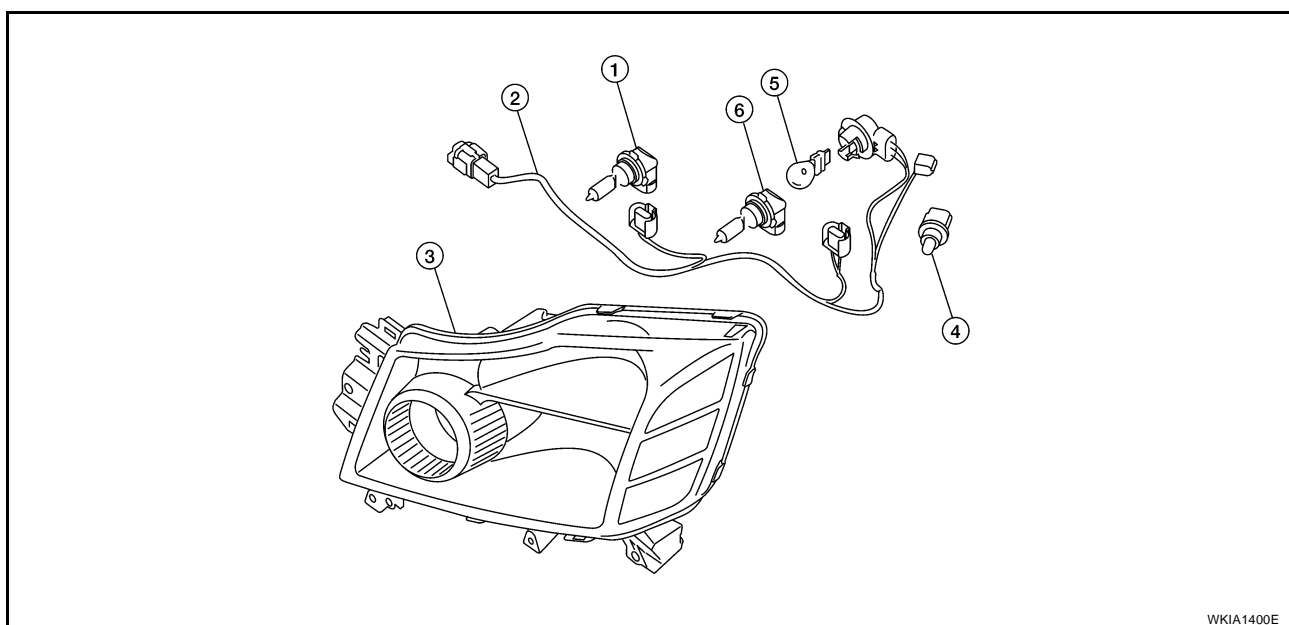

1. Headlamp bulb (high)
2. Wiring harness assembly (inner)
3. Headlamp assembly
4. Side marker lamp (front) bulb
5. Turn signal/parking lamp (front) bulb
6. Headlamp bulb (low beam)

### Disassembly

1. Turn high beam bulb counterclockwise to unlock and remove high beam bulb.
2. Turn low beam bulb counterclockwise to unlock and remove low beam bulb.
3. Turn turn signal/parking lamp (front) bulb socket counterclockwise to unlock and remove turn signal/parking lamp (front) bulb.
4. Turn side marker lamp (front) bulb socket counterclockwise to unlock and remove side marker lamp (front) bulb.

### Assembly

Assembly is in the reverse order of disassembly.

# HEADLAMP (FOR CANADA) - DAYTIME LIGHT SYSTEM -

## HEADLAMP (FOR CANADA) - DAYTIME LIGHT SYSTEM -

PF2:26010

### Component Parts and Harness Connector Location

EKS00A9G

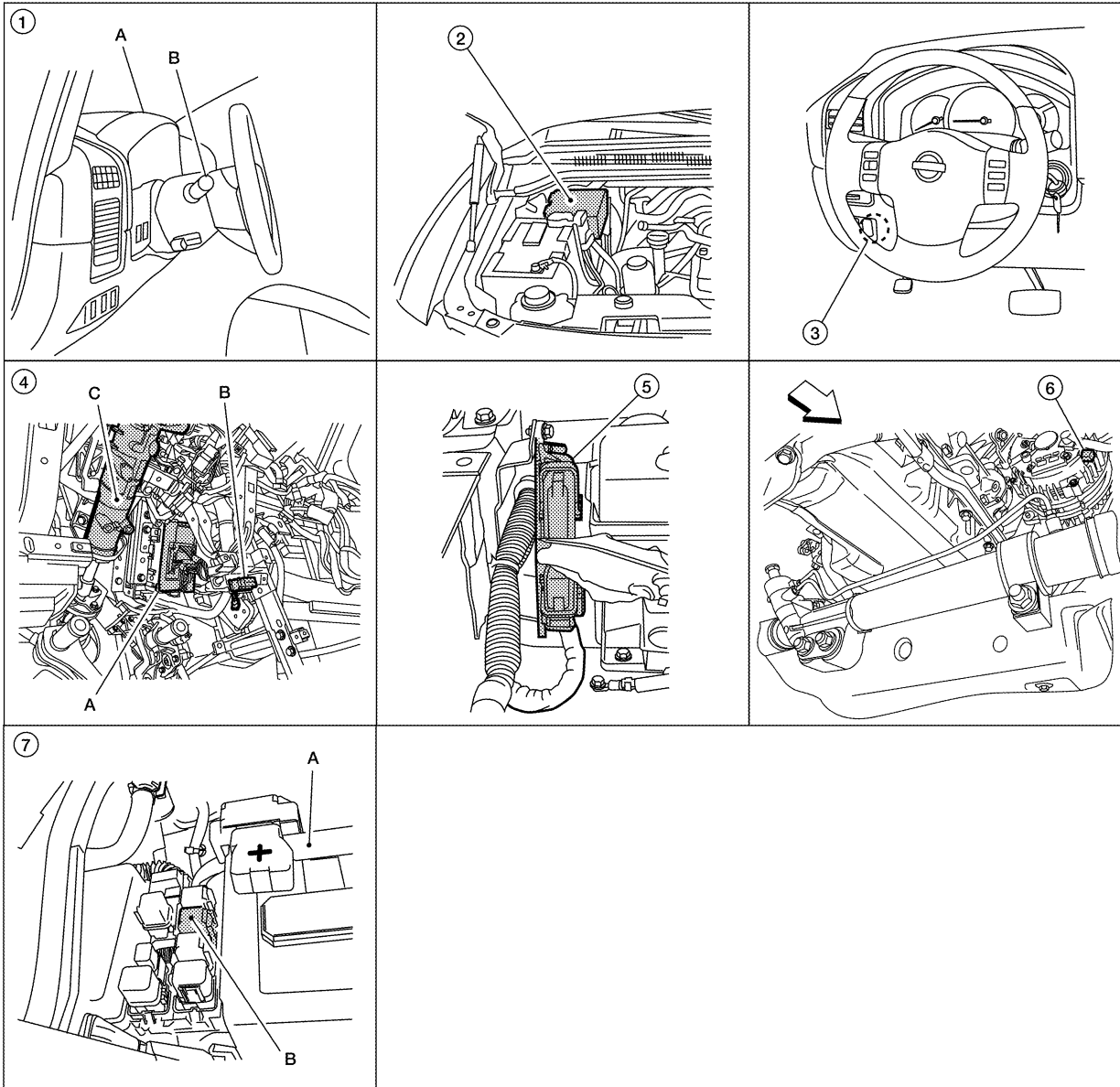

- |                                                                                                                                                                                                                                                                               |                                                                                            |                                                                                                              |
|-------------------------------------------------------------------------------------------------------------------------------------------------------------------------------------------------------------------------------------------------------------------------------|--------------------------------------------------------------------------------------------|--------------------------------------------------------------------------------------------------------------|
| <p>1. A. Combination meter M24<br/>B. Combination switch (lighting switch) M28</p> <p>4. A. BCM M18, M19 and M20<br/>B. Data link connector M22<br/>C. Steering column (view with instrument lower panel LH removed)</p> <p>7. A. Battery<br/>B. Daytime light relay E103</p> | <p>2. IPDM E/R E119, E122, E123 and E124</p> <p>5. ECM E16 (view with battery removed)</p> | <p>3. Parking brake switch M11</p> <p>6. ← Front of vehicle<br/>Generator E206 (view from under vehicle)</p> |
|-------------------------------------------------------------------------------------------------------------------------------------------------------------------------------------------------------------------------------------------------------------------------------|--------------------------------------------------------------------------------------------|--------------------------------------------------------------------------------------------------------------|

WKIA5593E

### System Description

EKS00A9H

Daytime light system turns on daytime light lamps while driving. Daytime light lamps are not turned on if engine is activated with parking brake on. Take off parking brake to turn on daytime light lamps. The lamps turn off when lighting switch is in the 2ND position or AUTO position (Headlamp is "ON") and when lighting switch is in the PASSING position. (Daytime light lamps are not turned off only by parking brake itself.) A parking brake signal and engine run or stop signal are sent to BCM (body control module) by CAN communication lines.

A  
B  
C  
D  
E  
F  
G  
H  
I  
J  
K  
L  
M

LT

# HEADLAMP (FOR CANADA) - DAYTIME LIGHT SYSTEM -

---

## OUTLINE

Power is supplied at all times

- to ignition relay, located in the IPDM E/R (intelligent power distribution module engine room),
- through 10A fuse [No. 19, located in the fuse block (J/B)]
- to combination meter terminal 8,
- through 50A fusible link (letter f , located in the fuse and fusible link box)
- to BCM terminal 70,
- through 20A fuse (No. 53, located in the IPDM E/R)
- to CPU (central processing unit) of the IPDM E/R, and
- through 10A fuse (No. 45, located in the IPDM E/R)
- to daytime light relay terminals 2 and 5.

When the ignition switch is in ON or START position, power is supplied

- through 10A fuse [No. 14, located in the fuse block (J/B)]
- to combination meter terminal 24, and
- through 10A fuse (No. 59, located in the fuse and relay box)
- to BCM terminal 38.

Ground is supplied

- to BCM terminal 67 and
- to combination meter terminal 17
- through grounds M57, M61 and M79.

## DAYTIME LIGHT OPERATION

With the engine running, the lighting switch in the OFF or 1ST position and parking brake released, the IPDM E/R receives input requesting the daytime lights illuminate. This input is communicated across the CAN communication lines. The CPU (central processing unit) of the IPDM E/R controls the daytime light relay coil. When energized, this relay directs power

- through daytime light relay terminal 3
- through front combination lamp LH terminal 3
- through front combination lamp LH terminal 2
- through IPDM E/R terminal 55
- through 10A fuse (No. 35, located in the IPDM E/R)
- through 10A fuse (No. 34, located in the IPDM E/R)
- through IPDM E/R terminal 56
- to front combination lamp RH terminal 2.

Ground is supplied

- to front combination lamp RH terminal 3
- through grounds E9, E15 and E24.

With power and ground supplied, the daytime lights illuminate. The high beam headlamps are now wired in series and illuminate at a reduced intensity.

## COMBINATION SWITCH READING FUNCTION

Refer to [BCS-3, "COMBINATION SWITCH READING FUNCTION"](#) .

## AUTO LIGHT OPERATION (IF EQUIPPED)

For auto light operation, refer to [LT-38, "System Description"](#) .

## CAN Communication System Description

Refer to [LAN-2, "CAN Communication System"](#) .

EKS00A9I

# HEADLAMP (FOR CANADA) - DAYTIME LIGHT SYSTEM -

## Schematic

EKS00A9J

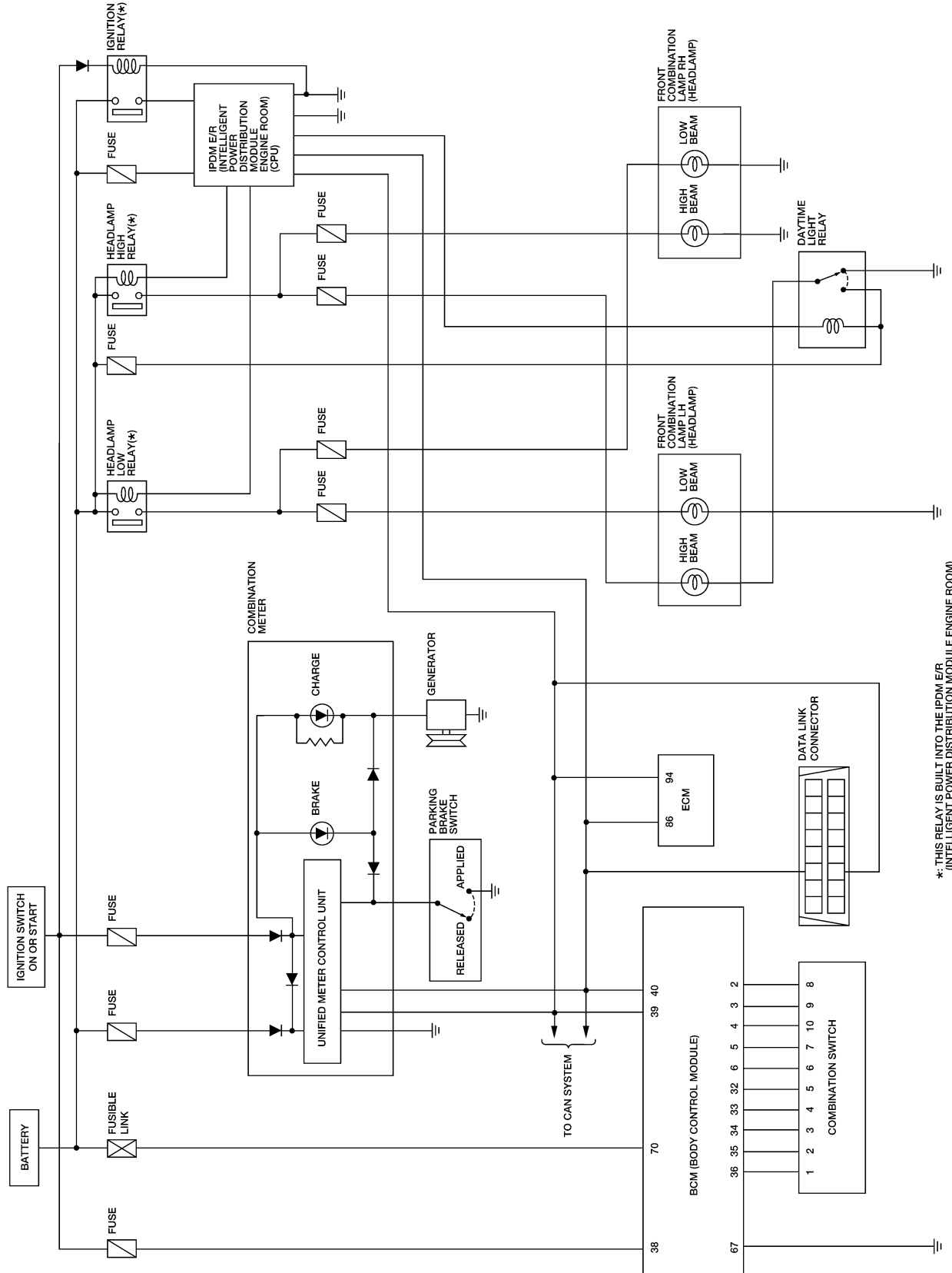

\*: THIS RELAY IS BUILT INTO THE IPDM E/R (INTELLIGENT POWER DISTRIBUTION MODULE ENGINE ROOM)

A  
B  
C  
D  
E  
F  
G  
H  
I  
J  
LT  
L  
M

# HEADLAMP (FOR CANADA) - DAYTIME LIGHT SYSTEM -

EKS00A9K

## Wiring Diagram — DTRL —

LT-DTRL-01

— : DATA LINE

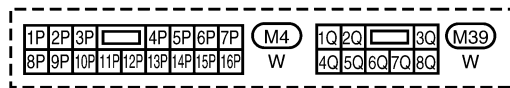
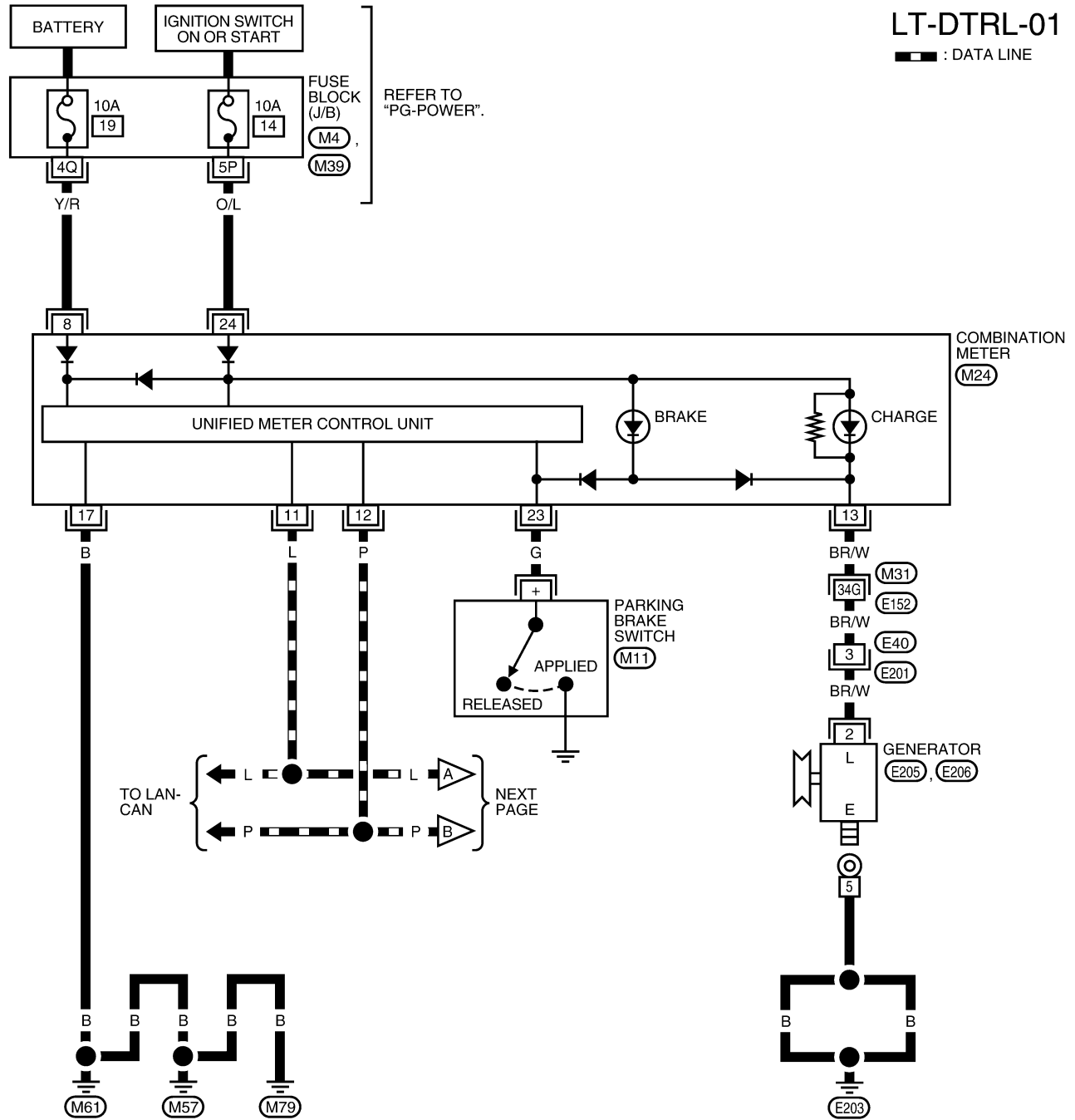

REFER TO THE FOLLOWING.

(M31) - SUPER MULTIPLE JUNCTION (SMJ)

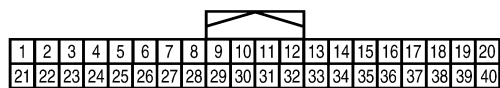

WKWA5153E

# HEADLAMP (FOR CANADA) - DAYTIME LIGHT SYSTEM -

LT-DTRL-02

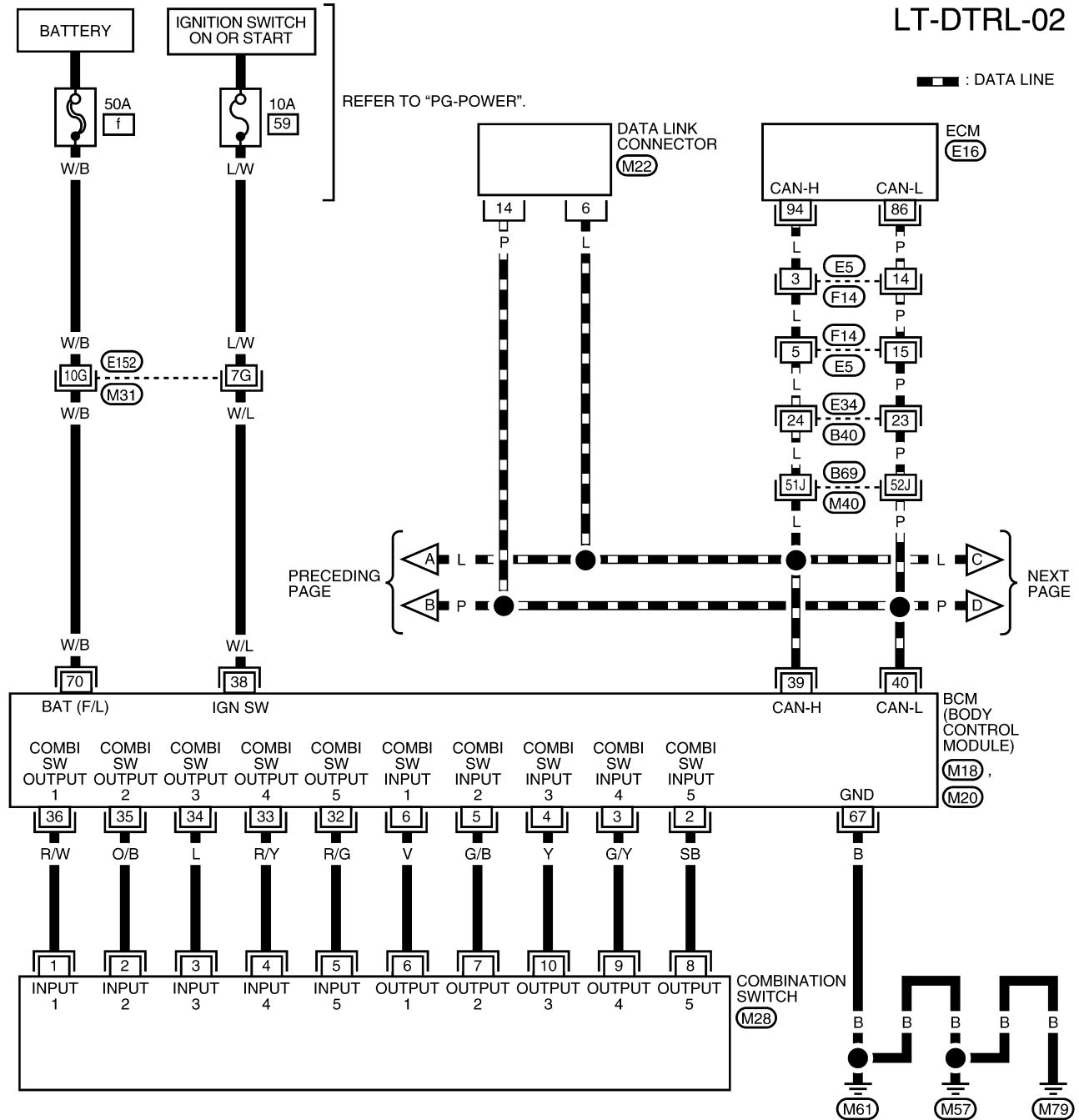

A  
B  
C  
D  
E  
F  
G  
H  
I  
J  
LT  
L  
M

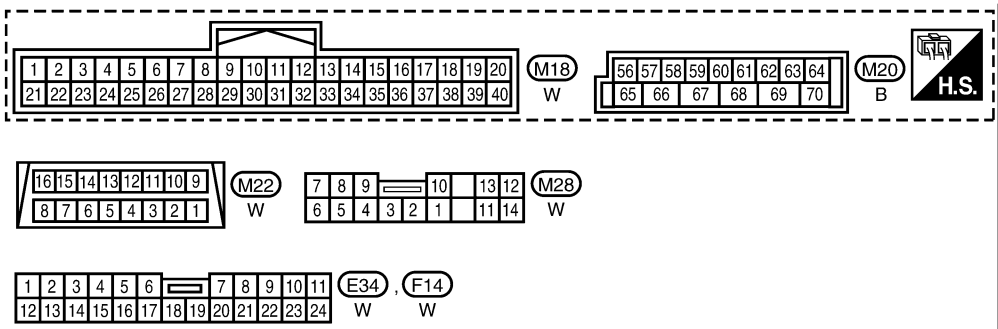

REFER TO THE FOLLOWING.  
 (E16) - ELECTRICAL UNITS  
 (M31), (M40) - SUPER MULTIPLE JUNCTION (SMJ)

WKWA3758E

# HEADLAMP (FOR CANADA) - DAYTIME LIGHT SYSTEM -

LT-DTRL-03

▬ : DATA LINE

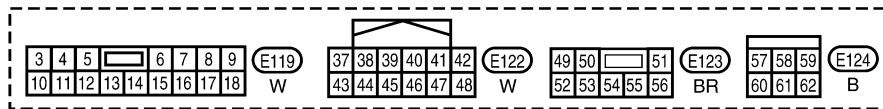
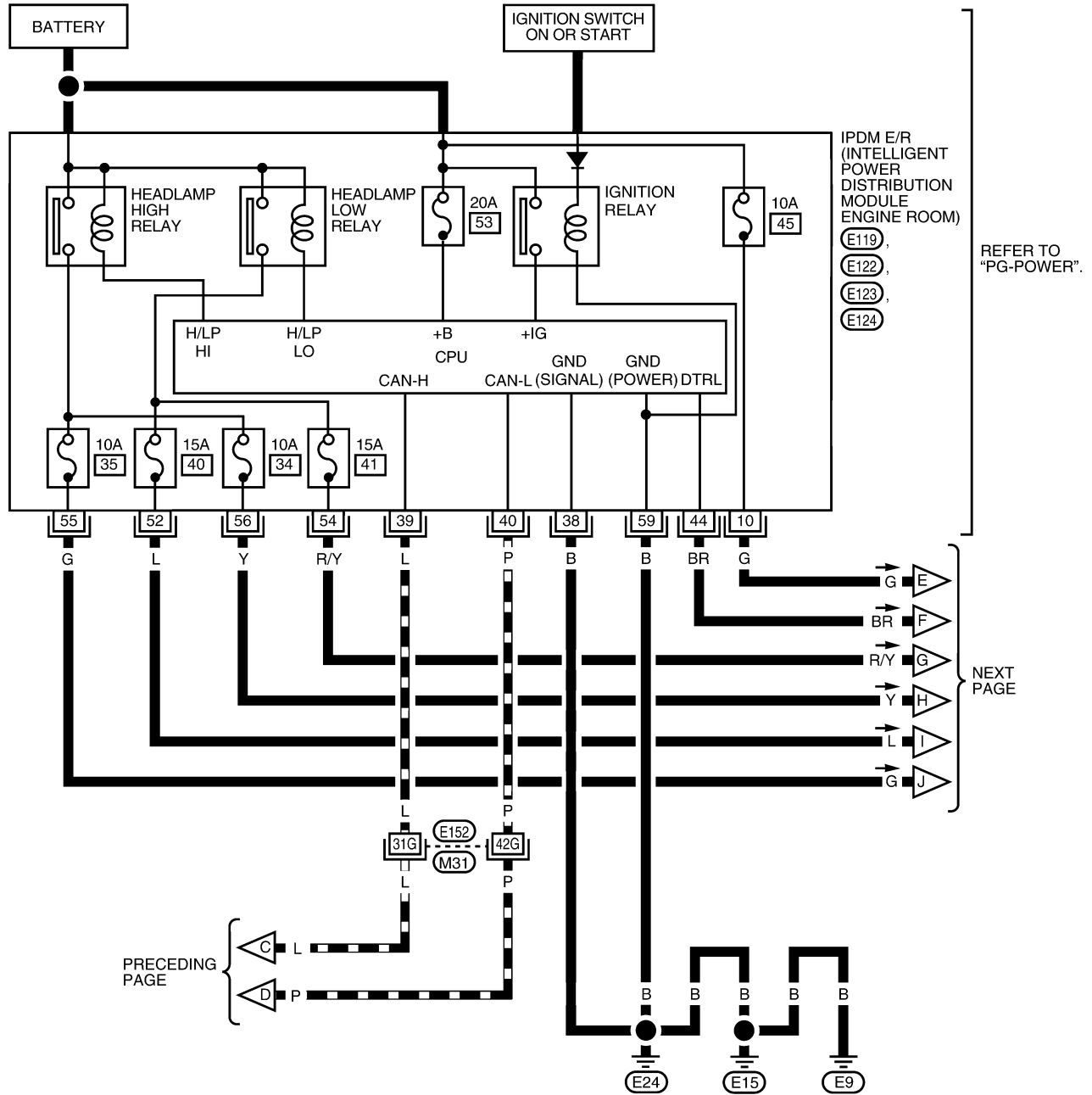

REFER TO THE FOLLOWING.  
 (M31) - SUPER MULTIPLE JUNCTION (SMJ)

WKWA3759E



# HEADLAMP (FOR CANADA) - DAYTIME LIGHT SYSTEM -

LT-DTRL-04

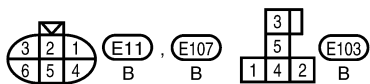
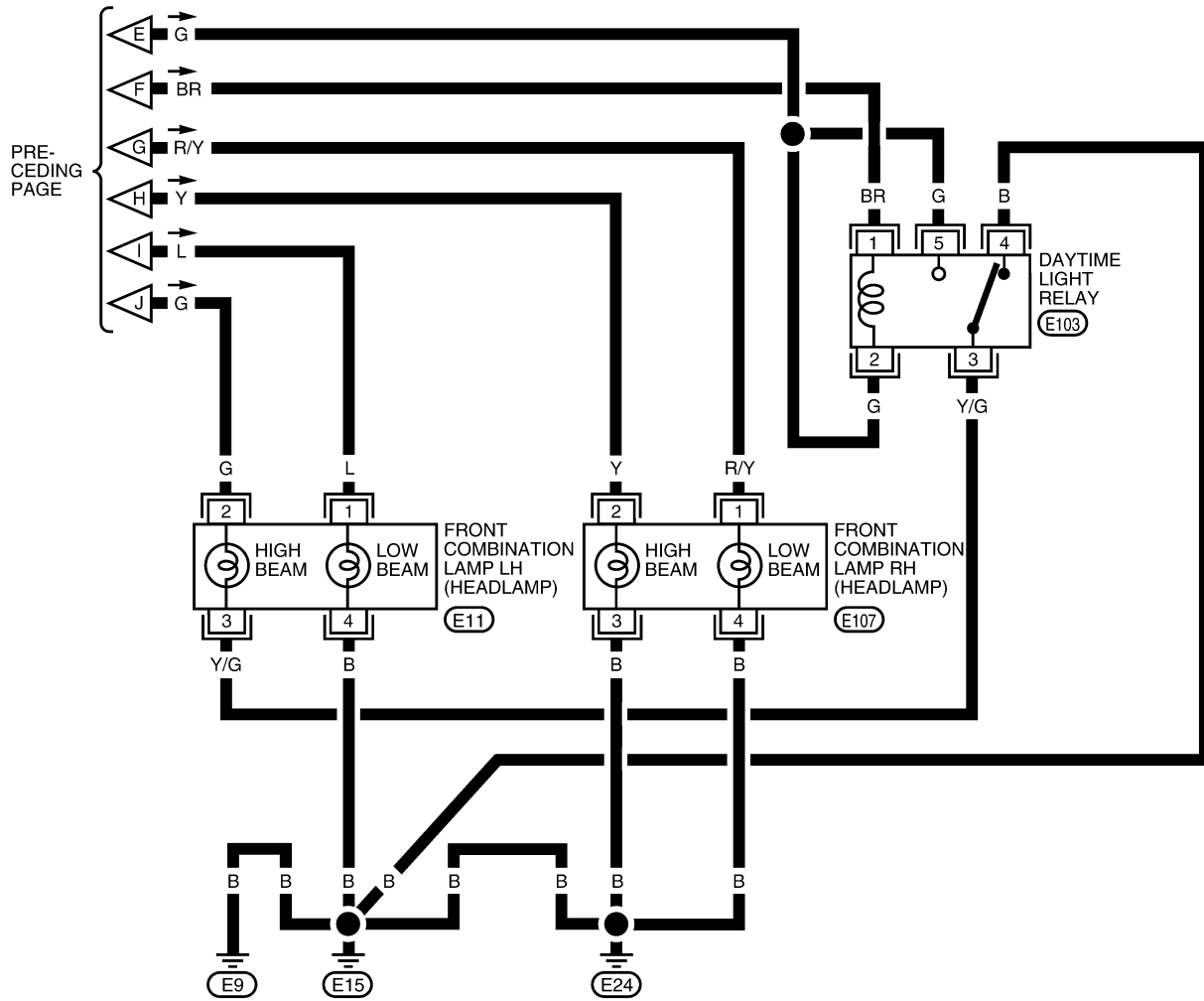

WKWA3760E

# HEADLAMP (FOR CANADA) - DAYTIME LIGHT SYSTEM -

## Terminals and Reference Values for BCM

EKS00A9L

Refer to [BCS-12, "Terminals and Reference Values for BCM"](#) .

## How to Proceed With Trouble Diagnosis

EKS00A9M

1. Confirm the symptom or customer complaint.
2. Understand operation description and function description. Refer to [LT-27, "System Description"](#) .
3. Perform the Preliminary Check. Refer to [LT-34, "Preliminary Check"](#) .
4. Check symptom and repair or replace the component.
5. Does the headlamp operate normally? If YES: GO TO 6. If NO: GO TO 4.
6. Inspection End.

## Preliminary Check

EKS00A9N

### CHECK BCM CONFIGURATION

#### 1. CHECK BCM CONFIGURATION

Confirm BCM configuration for "DTRL" is set to "WITH". Refer to [BCS-19, "READ CONFIGURATION PROCEDURE"](#) .

OK or NG

- OK >> Continue preliminary check. Refer to [LT-34, "CHECK POWER SUPPLY AND GROUND CIRCUIT TO BCM"](#) .
- NG >> Change BCM configuration for "DTRL" to "WITH". Refer to [BCS-22, "WRITE CONFIGURATION PROCEDURE"](#) .

### CHECK POWER SUPPLY AND GROUND CIRCUIT TO BCM

Refer to [BCS-16, "BCM Power Supply and Ground Circuit Check"](#) .

### INSPECTION PARKING BRAKE SWITCH CIRCUIT

#### 1. CHECK BRAKE INDICATOR

1. Turn ignition switch ON.
2. Apply parking brake.
3. Release parking brake.

**Brake indicator in combination meter should illuminate when parking brake is applied and turn OFF when released.**

OK or NG

- OK >> Inspection End.
- NG >> GO TO 2.

#### 2. CHECK PARKING BRAKE SWITCH SIGNAL

1. Disconnect parking brake switch connector.
2. Turn ignition switch ON.
3. Check voltage between parking brake switch harness connector M11 terminal + and ground.

**+ - Ground : Battery voltage should exist.**

OK or NG

- OK >> Replace parking brake switch.
- NG >> GO TO 3.

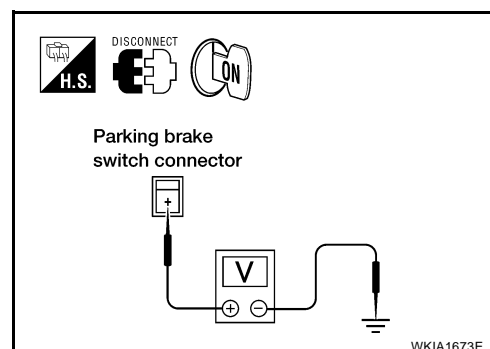

# HEADLAMP (FOR CANADA) - DAYTIME LIGHT SYSTEM -

## 3. CHECK PARKING BRAKE SWITCH CIRCUIT

1. Turn ignition switch OFF.
2. Disconnect combination meter connector.
3. Check continuity between combination meter harness connector M24 terminal 23 and parking brake switch harness connector M11 terminal +.

**+ - 23 : Continuity should exist.**

OK or NG

OK >> Replace combination meter. Refer to [IP-13, "COMBINATION METER"](#).

NG >> Repair harness or connector.

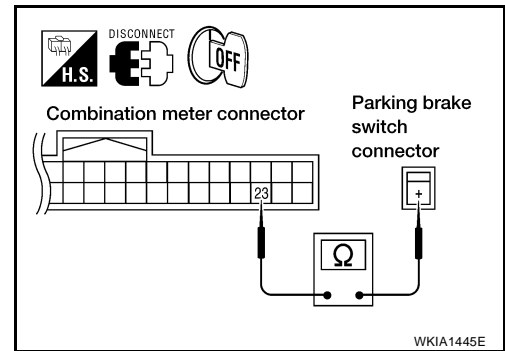

EKS00A90

## CONSULT-II Function (BCM)

Refer to [LT-12, "CONSULT-II Function \(BCM\)"](#).

## CONSULT-II Function (IPDM E/R)

Refer to [LT-13, "CONSULT-II Function \(IPDM E/R\)"](#).

EKS00A90

## Daytime Light Control Does Not Operate Properly (Normal Headlamps Operate Properly)

EKS00A9P

### 1. CHECK DAYTIME LIGHT RELAY FUSE

Inspect daytime light relay fuse 10A fuse (No. 45, located in the IPDM E/R).

OK or NG

OK >> GO TO 2.

NG >> Repair the short to ground in the daytime light relay power circuit.

### 2. CHECK DAYTIME LIGHT RELAY POWER SUPPLY CIRCUIT

1. Remove daytime light relay.
2. Check voltage between daytime light relay harness connector E103 terminals 2, 5 and ground.

**2, 5 - Ground : Battery voltage should exist.**

OK or NG

OK >> GO TO 3.

NG >> Repair harness or connector.

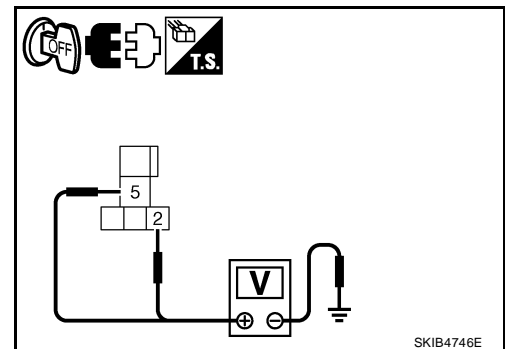

LT

### 3. CHECK DAYTIME LIGHT RELAY

1. Apply battery voltage to daytime light relay terminal 2 and ground terminal 1.
2. Check continuity between terminals 3 and 5.

**3 - 5 : Continuity should exist.**

OK or NG

OK >> GO TO 4.

NG >> Replace daytime light relay.

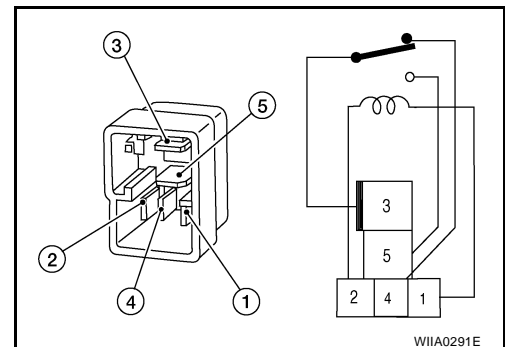

# HEADLAMP (FOR CANADA) - DAYTIME LIGHT SYSTEM -

## 4. CHECK INPUT SIGNAL

1. Connect daytime light relay and front combination lamp LH connector.
2. Start engine and release parking brake. Headlamp switch OFF.
3. Select "IPDM E/R" on CONSULT-II. With "DATA MONITOR", make sure "DTRL REQ" turns ON-OFF linked with operation of parking brake switch.

**Parking brake ON : DTRL REQ ON**  
**Parking brake OFF : DTRL REQ OFF**

OK or NG

- OK >> Replace IPDM E/R. Refer to [PG-30, "Removal and Installation of IPDM E/R"](#) .
- NG >> GO TO 5.

DATA MONITOR			
MONITOR			
DTRL REQ		OFF	
		RECORD	
MODE	BACK	LIGHT	COPY

WKIA1449E

## 5. CHECKING CAN COMMUNICATIONS

Select "BCM" on CONSULT-II and perform self-diagnosis for BCM.

Displayed self-diagnosis results

- NO DTC>>Replace BCM. Refer to [BCS-26, "BCM"](#) .
- CAN COMM CIRCUIT>> Check BCM CAN communication system.  
Refer to [LAN-5, "TROUBLE DIAGNOSIS"](#) .

SELF-DIAG RESULTS			
DTC RESULTS		TIME	
CAN COMM CIRCUIT [U1000]		PAST	
ERASE		PRINT	
MODE	BACK	LIGHT	COPY

SKIA1039E

### Aiming Adjustment

Refer to [LT-23, "Aiming Adjustment"](#) .

### Bulb Replacement

Refer to [LT-24, "Bulb Replacement"](#) .

### Removal and Installation

Refer to [LT-25, "Removal and Installation"](#) .

### Disassembly and Assembly

Refer to [LT-26, "Disassembly and Assembly"](#) .

EKS00A9Q

EKS00A9R

EKS00A9S

EKS00A9T

# AUTO LIGHT SYSTEM

PFP:28491

EKS00A9U

## AUTO LIGHT SYSTEM

### Component Parts and Harness Connector Location

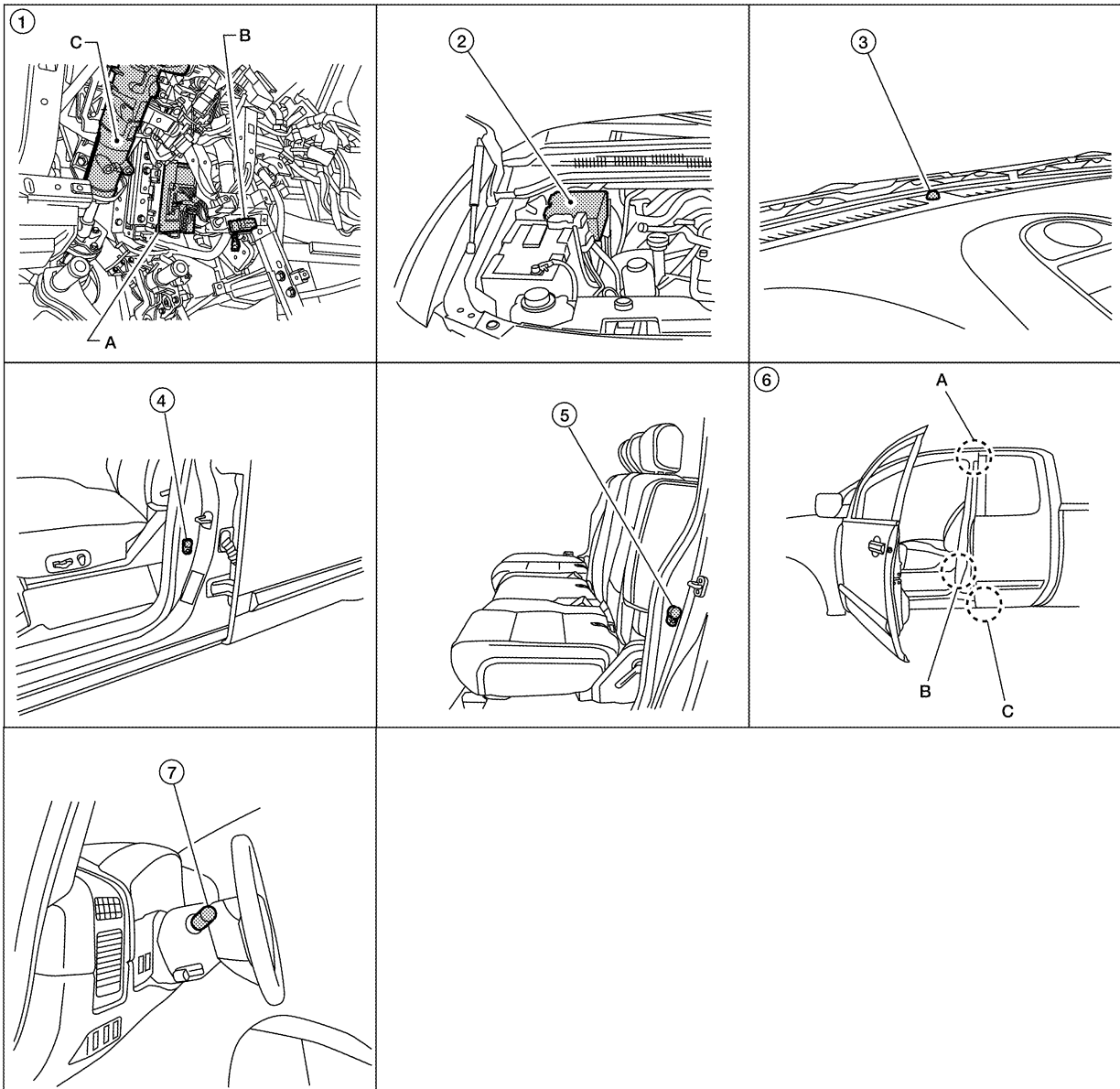

- WKIA5594E
1. A. BCM M18, M19 and M20  
B. Data link M22  
C. Steering column (view with instrument lower panel LH removed)
  2. IPDM E/R E122, E123 and E124
  3. Optical sensor M402
  4. Crew cab  
Front door switch LH B8 and RH B108
  5. Crew cab  
Rear door switch LH B18 and RH B116
  6. King Cab  
A. Rear door switch LH B73 and RH B156  
B. Front door switch LH B8 and RH B108  
C. Rear door switch LH B74 and RH B157
  7. Combination switch (lighting switch)  
M28

# AUTO LIGHT SYSTEM

EKS00A9V

## System Description

Automatically turns on/off the parking lamps and the headlamps in accordance with ambient light. Timing for when the lamps turn on/off can be selected using eight modes. Mode selections are accessed through the vehicle electronic settings menu of the display (refer to the Owner's Manual) or with the CONSULT-II.

### OUTLINE

The auto light control system uses an optical sensor that detects outside brightness. When the lighting switch is in "AUTO" position, it automatically turns on/off the parking lamps and the headlamps in accordance with the ambient light. Sensitivity can be adjusted in four steps. For the details of the setting, refer to [LT-44, "SETTING CHANGE FUNCTIONS"](#) .

Optical sensor ground is supplied

- to optical sensor terminal 3
- through BCM (body control module) terminal 18.

When ignition switch is turned to "ON" position and when outside brightness is darker than prescribed level, input is supplied

- to BCM terminal 58
- through optical sensor terminal 4.

The headlamps will then illuminate. For a description of headlamp operation, refer to [LT-5, "System Description"](#) .

### COMBINATION SWITCH READING FUNCTION

Refer to [BCS-3, "COMBINATION SWITCH READING FUNCTION"](#) .

### EXTERIOR LAMP BATTERY SAVER CONTROL

When the combination switch (lighting switch) is in the AUTO position, and the ignition switch is turned from ON or ACC to OFF, and one of the front doors is opened, the battery saver control feature is activated.

Under this condition, the headlamps remain illuminated for 5 minutes, then the headlamps are turned off.

Exterior lamp battery saver control mode can be changed by the function setting of CONSULT-II.

### DELAY TIMER FUNCTION

When the ignition switch is ON and auto light switch is ON, the BCM turns on/off the headlamps. In delay timer function, ignition is OFF, auto light sensor power source is OFF and the headlamps are not turned on/off by the BCM. On condition that:

- when the state of ignition switch ON or ACC is ON and output judgment by auto light function is headlamp ON changes to ignition switch and ACC are OFF and any door switch is ON, output judgment by BCM should be headlamp ON for 5 minutes by timer. After time out, output judgment by BCM should be headlamp OFF.
- when the state of any door switch is turned to ON from OFF while 45 second or 5 minute timer is counting, timer stops, and restarts counting for 5 minutes, then BCM judges output as headlamp ON. After time out, BCM judges output as headlamp OFF.
- when the state of front door switch (driver side), front door switch (passenger side), rear door switch LH, rear door switch RH or back door latch (door ajar switch) is ON turns to all door switches are OFF while 45 second or 5 minute timer is counting, timer stops, and restarts counting for 45 seconds, then BCM judges output as headlamp ON. After timer out, BCM judges output as headlamp OFF.
- when the state is ignition switch ON or ACC is ON or auto light switch OFF while timer is counting, timer stops counting and BCM turns on/off lamps according to headlamp function, front fog lamp function, auto light function and headlamp battery save function.

Delay timer control mode can be changed by the function setting of CONSULT-II.

## CAN Communication System Description

EKS00A9W

Refer to [LAN-2, "CAN Communication System"](#) .

# AUTO LIGHT SYSTEM

## Major Components and Functions

EKS00A9X

Components	Functions
BCM	<ul style="list-style-type: none"><li>● Turns on/off circuits of tail light and headlamp according to signals from light sensor, lighting switch (AUTO), driver door switch, passenger door switch, rear door switch, and ignition switch (ON, OFF).</li></ul>
Optical sensor	<ul style="list-style-type: none"><li>● Converts ambient light (lux) to voltage, and sends it to BCM. (Detects lightness of 50 to 1,300 lux)</li></ul>

A

B

C

D

E

F

G

H

I

J

LT

L

M

# AUTO LIGHT SYSTEM

## Schematic

EKS00A9Y

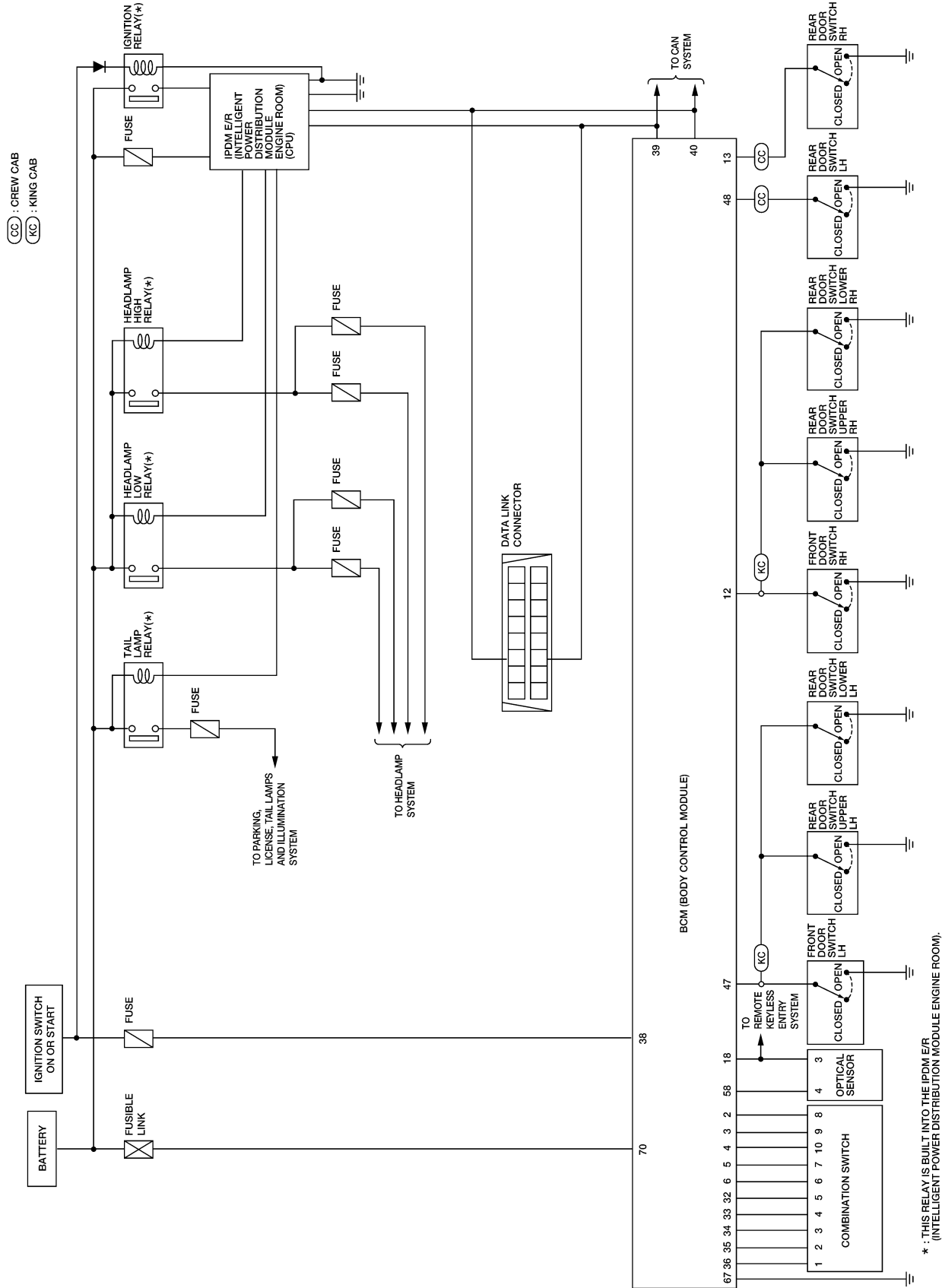

WKWA3761E



# AUTO LIGHT SYSTEM

## Wiring Diagram — AUTO/L —

EKS00A9Z

LT-AUTO/L-01

— : DATA LINE

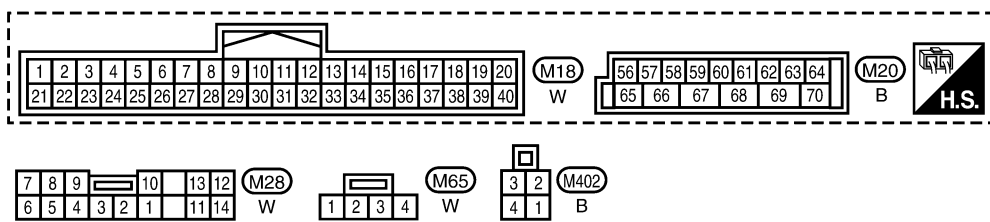
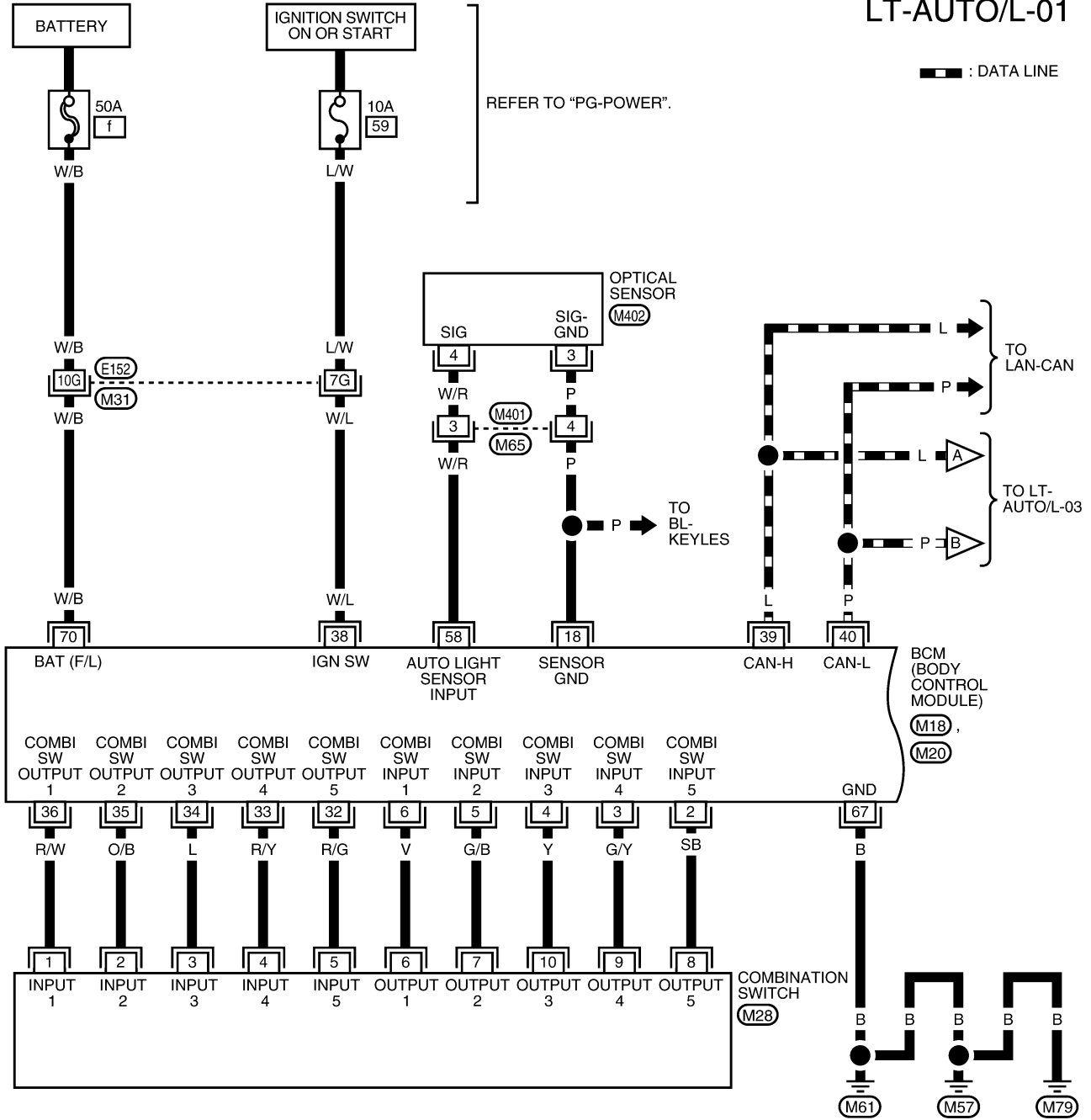

# AUTO LIGHT SYSTEM

LT-AUTO/L-02

CC : CREW CAB  
KC : KING CAB

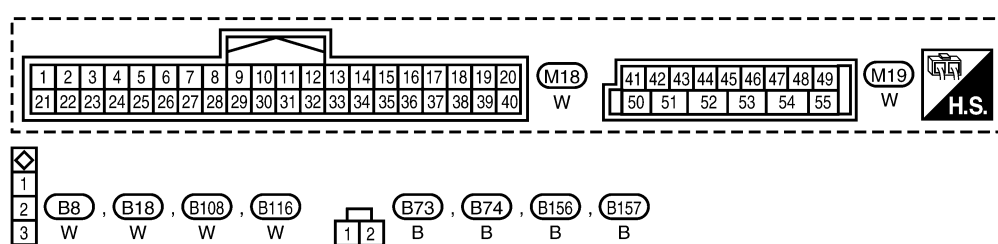
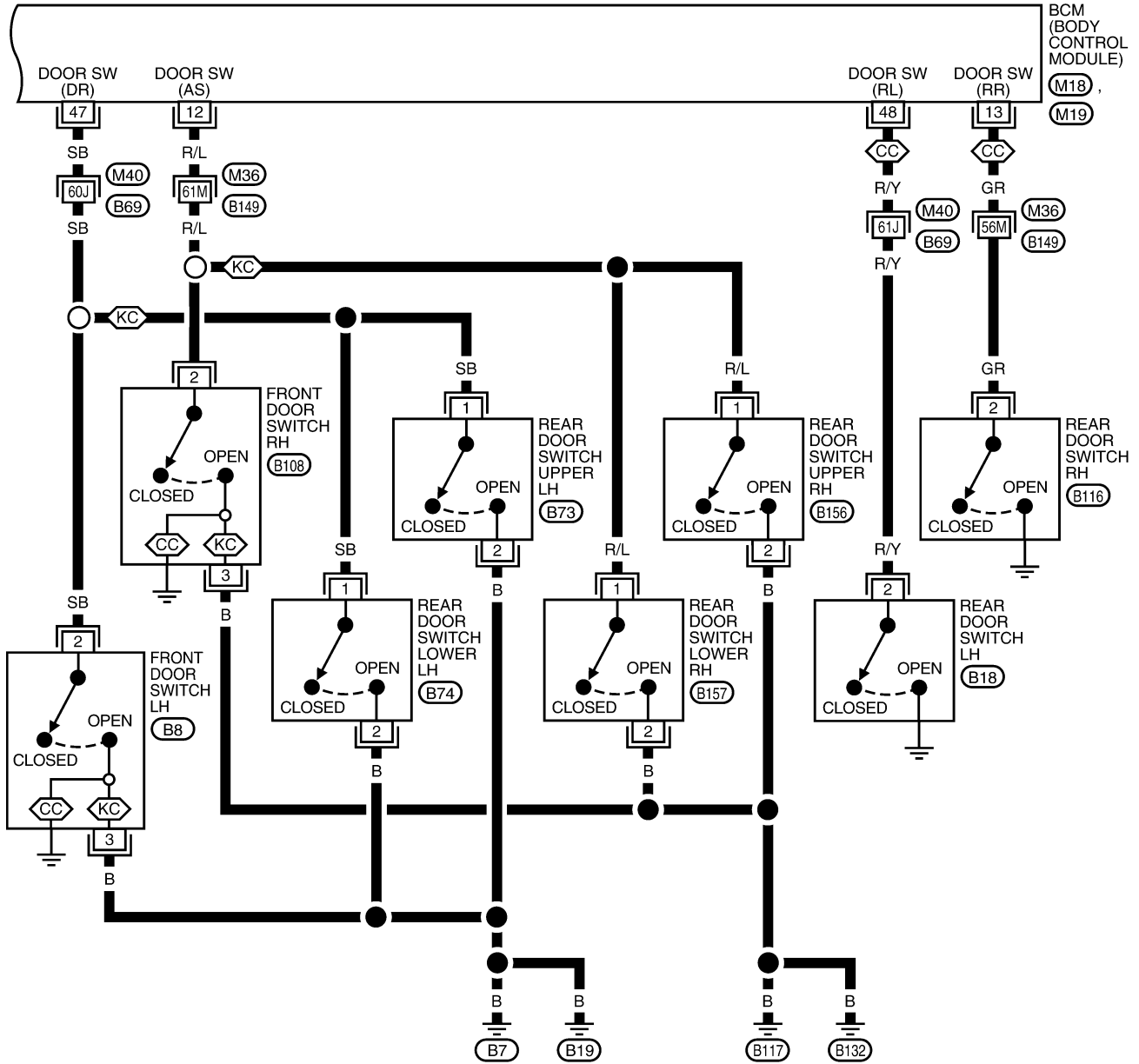

REFER TO THE FOLLOWING.  
M36 , M40 - SUPER  
 MULTIPLE JUNCTION (SMJ)

LKWA0282E

# AUTO LIGHT SYSTEM

LT-AUTO/L-03

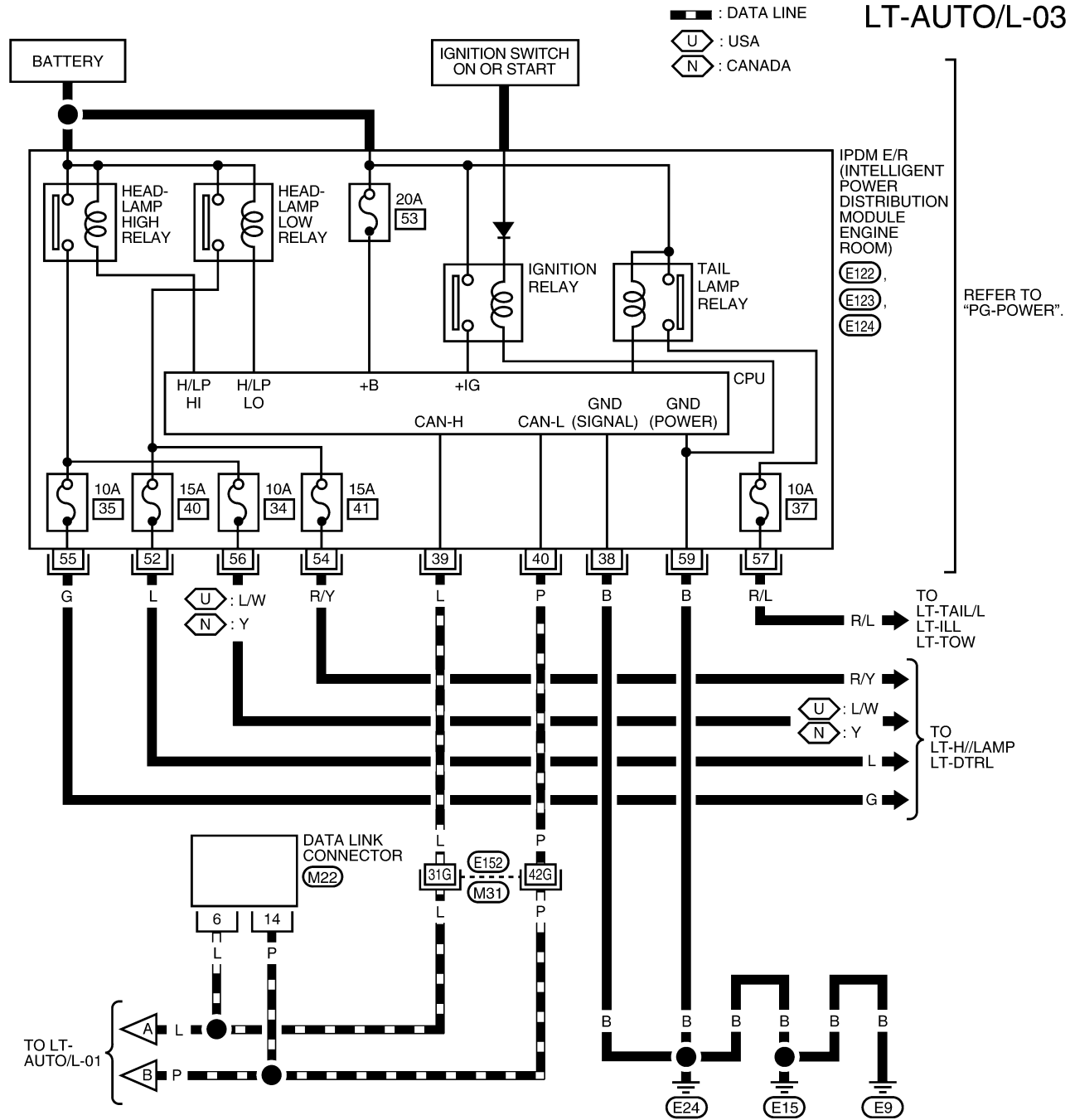

A  
B  
C  
D  
E  
F  
G  
H  
I  
J  
LT  
L  
M

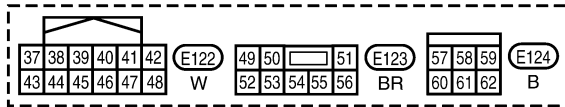
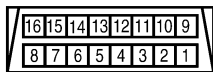

REFER TO THE FOLLOWING.  
**(M31)** - SUPER MULTIPLE JUNCTION (SMJ)

WKWA2445E

# AUTO LIGHT SYSTEM

## Terminals and Reference Values for BCM

EKS00AA0

Refer to [BCS-12, "Terminals and Reference Values for BCM"](#) .

## Terminals and Reference Values for IPDM E/R

EKS00AA1

Refer to [PG-24, "Terminals and Reference Values for IPDM E/R"](#) .

## How to Proceed With Trouble Diagnosis

EKS00AA2

1. Confirm the symptom or customer complaint.
2. Understand operation description and function description. Refer to [LT-38, "System Description"](#) .
3. Carry out the Preliminary Check. Refer to [LT-44, "Preliminary Check"](#) .
4. Check symptom and repair or replace the component. Refer to [LT-46, "Trouble Diagnosis Chart by Symptom"](#) .
5. Does the auto light system operate normally? If YES: GO TO 6. If NO: GO TO 4.
6. Inspection End.

## Preliminary Check

EKS00AA3

### SETTING CHANGE FUNCTIONS

- Sensitivity of auto light system can be adjusted using CONSULT-II. Refer to [LT-44, "WORK SUPPORT"](#) .

### CHECK BCM CONFIGURATION

#### 1. CHECK BCM CONFIGURATION

Confirm BCM configuration for "AUTO LIGHT" is set to "WITH". Refer to [BCS-19, "READ CONFIGURATION PROCEDURE"](#) .

OK or NG

- OK >> Continue preliminary check. Refer to [LT-44, "CHECK POWER SUPPLY AND GROUND CIRCUIT TO BCM"](#) .
- NG >> Change BCM configuration for "AUTO LIGHT" to "WITH". Refer to [BCS-22, "WRITE CONFIGURATION PROCEDURE"](#) .

### CHECK POWER SUPPLY AND GROUND CIRCUIT TO BCM

Refer to [BCS-16, "BCM Power Supply and Ground Circuit Check"](#) .

### CHECK POWER SUPPLY AND GROUND CIRCUIT TO IPDM E/R

Refer to [PG-24, "Terminals and Reference Values for IPDM E/R"](#) .

## CONSULT-II Function (BCM)

EKS00AA4

Refer to [BCS-18, "CONSULT-II Function \(BCM\)"](#) .

### CONSULT-II START PROCEDURE

Refer to [GI-38, "CONSULT-II Start Procedure"](#) .

## WORK SUPPORT

### Work Support Setting Item

- Sensitivity of auto light can be selected and set from four modes.

Work item	Description
CUSTOM A/LIGHT SETTING	Auto light sensitivity can be changed in this mode. Sensitivity can be adjusted in four modes. <ul style="list-style-type: none"><li>● MODE 1 (Normal-default)/ MODE 2 (Desensitized)/MODE 3 (Sensitive)/MODE4 (Insensitive)</li></ul>
ILL DELAY SET	Auto light delay off timer period can be changed in this mode. Selects auto light delay off timer period among eight modes. <ul style="list-style-type: none"><li>● MODE 1 (45 sec.)/MODE 2 (OFF)/MODE 3 (30 sec.)/MODE 4 (60 sec.)/MODE 5 (90 sec.)/MODE 6 (120 sec.)/MODE 7 (150 sec.)/MODE 8 (180 sec.)</li></ul>

# AUTO LIGHT SYSTEM

## DATA MONITOR Display Item List

Monitor item	Contents
IGN ON SW "ON/OFF"	Displays "IGN position (ON)/OFF, ACC position (OFF)" judged from the ignition switch signal.
ACC ON SW "ON/OFF"	Displays "ACC (ON)/OFF, Ignition OFF (OFF)" status judged from ignition switch signal.
HI BEAM SW "ON/OFF"	Displays status (high beam switch: ON/Others: OFF) of high beam switch judged from lighting switch signal.
HEAD LAMP SW 1 "ON/OFF"	Displays status (headlamp switch 1: ON/Others: OFF) of headlamp switch 2 judged from lighting switch signal.
HEAD LAMP SW 2 "ON/OFF"	Displays status (headlamp switch 2: ON/Others: OFF) of headlamp switch 2 judged from lighting switch signal.
LIGHT SW 1ST "ON/OFF"	Displays status (lighting switch 1st position: ON/Others: OFF) of lighting switch judged from lighting switch signal.
AUTO LIGHT SW "ON/OFF"	Displays status of the lighting switch as judged from the lighting switch signal. (AUTO position: ON/Other than AUTO position: OFF)
PASSING SW "ON/OFF"	Displays status (flash-to-pass switch: ON/Others: OFF) of flash-to-pass switch judged from lighting switch signal.
FR FOG SW "ON/OFF"	Displays status (front fog lamp switch: ON/Others: OFF) of front fog lamp switch judged from lighting switch signal.
DOOR SW-DR "ON/OFF"	Displays status of the front door LH as judged from the front door switch LH signal. (Door is open: ON/Door is closed: OFF)
DOOR SW-AS "ON/OFF"	Displays status of the front door RH as judged from the front door switch RH signal. (Door is open: ON/Door is closed: OFF)
DOOR SW-RR "ON/OFF"	Displays status of the rear door as judged from the rear door switch (RH) signal. (Door is open: ON/Door is closed: OFF)
DOOR SW-RL "ON/OFF"	Displays status of the rear door as judged from the rear door switch (LH) signal. (Door is open: ON/Door is closed: OFF)
BACK DOOR SW "ON/OFF"	Not used.
TURN SIGNAL R "ON/OFF"	Displays status (Turn right: ON/Others: OFF) as judged from lighting switch signal.
TURN SIGNAL L "ON/OFF"	Displays status (Turn left: ON/Others: OFF) as judged from lighting switch signal.
CARGO LAMP SW "ON/OFF"	Displays status of cargo lamp.
OPTICAL SENSOR [0 - 5V]	Displays "ambient light (close to 5V when dark/close to 0V when light)" judged from optical sensor signal.

## ACTIVE TEST Display Item List

Test item	Description
TAIL LAMP	Allows tail lamp relay to operate by switching ON-OFF.
HEAD LAMP	Allows headlamp relay (HI, LO) to operate by switching ON-OFF.
FR FOG LAMP	Allows fog lamp relay to operate by switching ON-OFF.
CARGO LAMP	Allows cargo lamp to operate by switching ON-OFF.

## SELF-DIAGNOSTIC RESULTS Display Item List

Monitored item	CONSULT-II display	Description
CAN communication	CAN communication [U1000]	Malfunction is detected in CAN communication.
CAN communication system	CAN communication system 1 to 6 [U1000]	Malfunction is detected in CAN system.

## CONSULT-II Function (IPDM E/R)

EKS00AA5

Refer to [PG-20, "CONSULT-II Function \(IPDM E/R\)"](#) .

# AUTO LIGHT SYSTEM

## CONSULT-II START PROCEDURE

Refer to [GI-38, "CONSULT-II Start Procedure"](#) .

## DATA MONITOR

### All Items, Main Items, Select Item Menu

Item name	CONSULT-II screen display	Display or unit	Monitor item selection			Description
			ALL SIGNALS	MAIN SIGNALS	SELECTION FROM MENU	
Parking, license plate and tail lamps request	TAIL&CLR REQ	ON/OFF	×	×	×	Signal status input from BCM
Headlamp low beam request	HL LO REQ	ON/OFF	×	×	×	Signal status input from BCM
Headlamp high beam request	HL HI REQ	ON/OFF	×	×	×	Signal status input from BCM
Front fog lamps request	FR FOG REQ	ON/OFF	×	×	×	Signal status input from BCM

### NOTE:

Perform monitoring of IPDM E/R data with the ignition switch ON. When the ignition switch is at ACC, the display may not be correct.

## ACTIVE TEST

Test item	CONSULT-II screen display	Description
Tail lamp relay output	TAIL LAMP	Allows tail lamp relay to operate by switching operation ON-OFF at your option.
Headlamp relay (HI, LO) output	LAMPS	Allows headlamp relay (HI, LO) to operate by switching operation (OFF, HI, LO) at your option (Headlamp high beam repeats ON-OFF every 1 second).
Front fog lamp relay output		Allows fog lamp relay to operate by switching operation ON-OFF at your option.

## Trouble Diagnosis Chart by Symptom

EKS00AA6

Trouble phenomenon	Malfunction system and reference
<ul style="list-style-type: none"> <li>● Parking lamps and headlamps will not illuminate when outside of the vehicle becomes dark. (Lighting switch 1st position and 2nd position operate normally.)</li> <li>● Parking lamps and headlamp will not go out when outside of the vehicle becomes light. (Lighting switch 1st position and 2nd position operate normally.)</li> <li>● Headlamps go out when outside of the vehicle becomes light, but parking lamps stay on.</li> </ul>	<ul style="list-style-type: none"> <li>● Refer to <a href="#">LT-44, "WORK SUPPORT"</a> .</li> <li>● Refer to <a href="#">LT-47, "Lighting Switch Inspection"</a> .</li> <li>● Refer to <a href="#">LT-47, "Optical Sensor System Inspection"</a> .</li> </ul> <p>If above systems are normal, replace BCM. Refer to <a href="#">BCS-26, "BCM"</a> .</p>
Parking lamps illuminate when outside of the vehicle becomes dark, but headlamps stay off. (Lighting switch 1st position and 2nd position operate normally.)	<ul style="list-style-type: none"> <li>● Refer to <a href="#">LT-44, "WORK SUPPORT"</a> .</li> <li>● Refer to <a href="#">LT-47, "Optical Sensor System Inspection"</a> .</li> </ul> <p>If above systems are normal, replace BCM. Refer to <a href="#">BCS-26, "BCM"</a> .</p>
Auto light adjustment system will not operate. (Lighting switch AUTO, 1st position and 2nd position operate normally.)	<ul style="list-style-type: none"> <li>● Refer to <a href="#">LT-47, "Optical Sensor System Inspection"</a> .</li> </ul> <p>If above system is normal, replace BCM. Refer to <a href="#">BCS-26, "BCM"</a> .</p>
Auto light adjustment system will not operate.	<ul style="list-style-type: none"> <li>● CAN communication line to BCM inspection. Refer to <a href="#">LAN-5, "TROUBLE DIAGNOSIS"</a> .</li> </ul>
Shut off delay feature will not operate.	<ul style="list-style-type: none"> <li>● CAN communication line inspection between BCM and combination meter. Refer to <a href="#">LAN-5, "TROUBLE DIAGNOSIS"</a> .</li> <li>● Refer to <a href="#">BL-32, "Door Switch Check (King Cab)"</a> .</li> </ul> <p>If above system is normal, replace BCM. Refer to <a href="#">BCS-26, "BCM"</a> .</p>

# AUTO LIGHT SYSTEM

## Lighting Switch Inspection

EKS00AA7

### 1. CHECK LIGHTING SWITCH INPUT SIGNAL

④ With CONSULT-II

Select "BCM" on CONSULT-II. With "HEAD LAMP" data monitor, make sure "AUTO LIGHT SW" turns ON-OFF linked with operation of lighting switch.

**When lighting switch is in AUTO position : AUTO LIGHT SW ON**

⊗ Without CONSULT-II

Refer to [LT-77, "Combination Switch Inspection"](#) .

OK or NG

OK >> Inspection End.

NG >> Check lighting switch. Refer to [LT-77, "Combination Switch Inspection"](#) .

DATA MONITOR	
MONITOR	
AUTO LIGHT SW	ON

SKIA4196E

## Optical Sensor System Inspection

EKS00AA8

### 1. CHECK OPTICAL SENSOR INPUT SIGNAL

④ With CONSULT-II

Select "BCM" on CONSULT-II. With "OPTICAL SENSOR" data monitor, check difference in the voltage when the optical sensor is illuminated and not illuminated.

**Illuminated**

**OPTICAL SENSOR : 3.1V or more**

**Not illuminated**

**OPTICAL SENSOR : 0.6V or less**

#### NOTE:

Optical sensor must be completely subjected to work lamp light. If the optical sensor is insufficiently illuminated, the measured value may not satisfy the standard.

⊗ Without CONSULT-II

GO TO 2.

OK or NG

OK >> Inspection End.

NG >> GO TO 2.

DATA MONITOR	
MONITOR	
OPTICAL SENSOR	XXXV

WKIA0486E

### 2. CHECK OPTICAL SENSOR SIGNAL GROUND CIRCUIT

1. Turn ignition switch OFF.
2. Disconnect BCM connectors and optical sensor connector.
3. Check continuity (open circuit) between BCM harness connector M18 terminal 18 and optical sensor harness connector M402 terminal 3.

**18 - 3 : Continuity should exist.**

4. Check continuity (short circuit) between BCM harness connector M18 terminal 18 (P) and ground.

**18 - Ground : Continuity should not exist.**

OK or NG

OK >> GO TO 3.

NG >> Repair harness or connector.

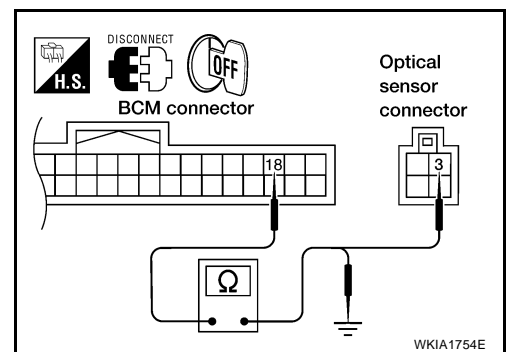

# AUTO LIGHT SYSTEM

## 3. CHECK OPTICAL SENSOR SIGNAL CIRCUIT

1. Check continuity (open circuit) between BCM harness connector M20 terminal 58 and optical sensor harness connector M402 terminal 4.

**58 - 4 : Continuity should exist.**

2. Check continuity (short circuit) between BCM harness connector M20 terminal 58 and ground.

**58 - Ground : Continuity should not exist.**

### OK or NG

- OK >> Replace optical sensor. Refer to [LT-49, "Removal and Installation"](#) . Recheck sensor output with CONSULT-II.  
If NG, replace BCM. Refer to [BCS-26, "BCM"](#) .
- NG >> Repair harness or connector.

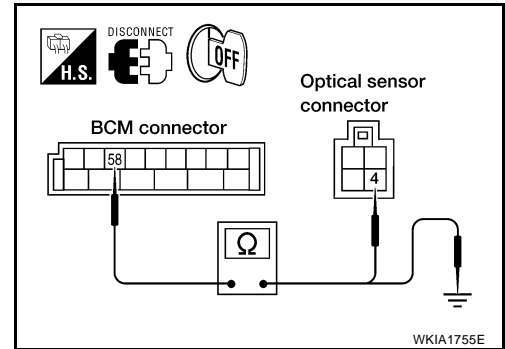



# AUTO LIGHT SYSTEM

## Removal and Installation

EKS00AA9

### OPTICAL SENSOR

#### Removal

1. Remove defroster grille. Refer to [IP-10, "INSTRUMENT PANEL ASSEMBLY"](#) .
2. Disconnect the connector.
3. Turn the optical sensor counterclockwise to remove it from defroster grille.

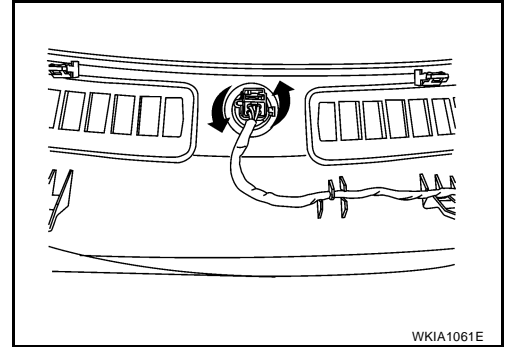

#### Installation

Installation is in the reverse order of removal.

A  
B  
C  
D  
E  
F  
G  
H  
I  
J  
LT  
L  
M

# FRONT FOG LAMP

## FRONT FOG LAMP

PFP:26150

### Component Parts and Harness Connector Location

EKS00AAA

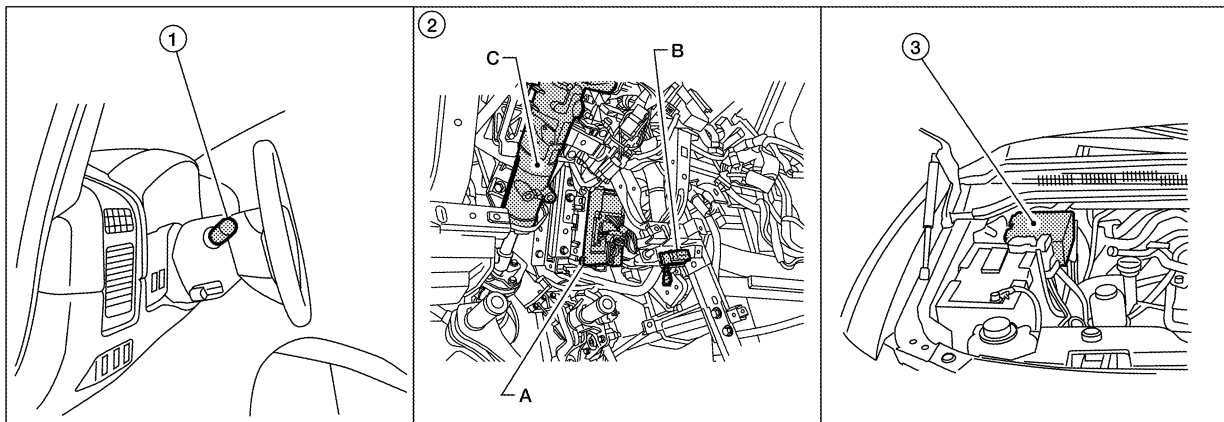

WKIA5595E

1. Combination switch M28
2. A. BCM M18 and M20  
B. Data link connector M22  
C. Steering column (view with instrument lower panel LH removed)
3. IPDM E/R E122, E123 and E124

## System Description

EKS00AAB

Control of the fog lamps is dependent upon the position of the combination switch (lighting switch). The lighting switch must be in the 2ND position or AUTO position (LOW beam is ON) for front fog lamp operation. When the lighting switch is placed in the fog lamp position, the BCM (body control module) receives input signal requesting the fog lamps to illuminate. When the headlamps are illuminated, this input signal is communicated to the IPDM E/R (intelligent power distribution module engine room) across the CAN communication lines. The CPU (central processing unit) of the IPDM E/R controls the front fog lamp relay coil. When activated, this relay directs power to the front fog lamps.

## OUTLINE

Power is supplied at all times

- to ignition relay, located in the IPDM E/R,
- to front fog lamp relay, located in the IPDM E/R,
- through 20A fuse (No. 53, located in the IPDM E/R)
- to CPU of the IPDM E/R, and
- through 50A fusible link (letter f , located in the fuse and fusible link box)
- to BCM terminal 70.

When the ignition switch is in ON or START position, power is supplied

- to ignition relay, located in the IPDM E/R, and
- through 10A fuse (No. 59, located in the fuse and relay box)
- to BCM terminal 38.

Ground is supplied

- to BCM terminal 67
- through grounds M57, M61 and M79, and
- to IPDM E/R terminals 38 and 59
- through grounds E9, E15 and E24.

## FOG LAMP OPERATION

The fog lamp switch is built into the combination switch. The lighting switch must be in the 2ND position or AUTO position (LOW beam is ON) and the fog lamp switch must be ON for fog lamp operation.

# FRONT FOG LAMP

With the fog lamp switch in the ON position, the CPU of the IPDM E/R grounds the coil side of the front fog lamp relay. The front fog lamp relay then directs power

- through 20A fuse (No. 56, located in the IPDM E/R)
- through IPDM E/R terminal 50
- to front fog lamp LH terminal +, and
- through IPDM E/R terminal 51
- to front fog lamp RH terminal +.

Ground is supplied

- to front fog lamp LH and RH terminal –
- through grounds E9, E15 and E24.

With power and ground supplied, the front fog lamps illuminate.

## COMBINATION SWITCH READING FUNCTION

Refer to [BCS-3, "COMBINATION SWITCH READING FUNCTION"](#) .

## EXTERIOR LAMP BATTERY SAVER CONTROL

When the combination switch (lighting switch) is in the 2ND position (ON), the fog lamp switch is ON, and the ignition switch is turned from ON or ACC to OFF, the battery saver control feature is activated.

Under this condition, the fog lamps (and headlamps) remain illuminated for 5 minutes, then the fog lamps (and headlamps) are turned off.

Exterior lamp battery saver control mode can be changed by the function setting of CONSULT-II.

## CAN Communication System Description

EKS00AAC

Refer to [LAN-2, "CAN Communication System"](#) .

A  
B  
C  
D  
E  
F  
G  
H  
I  
J  
L  
M

LT

# FRONT FOG LAMP

## Wiring Diagram — F/FOG —

EKS00AAD

### LT-F/FOG-01

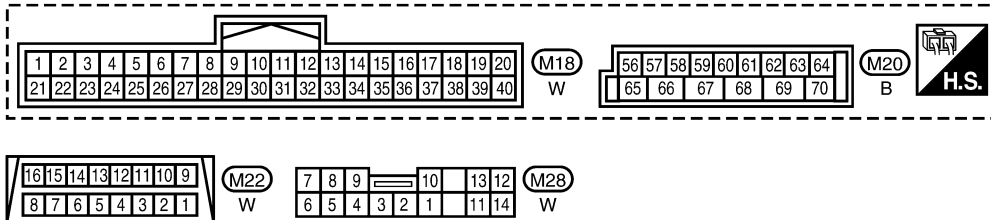
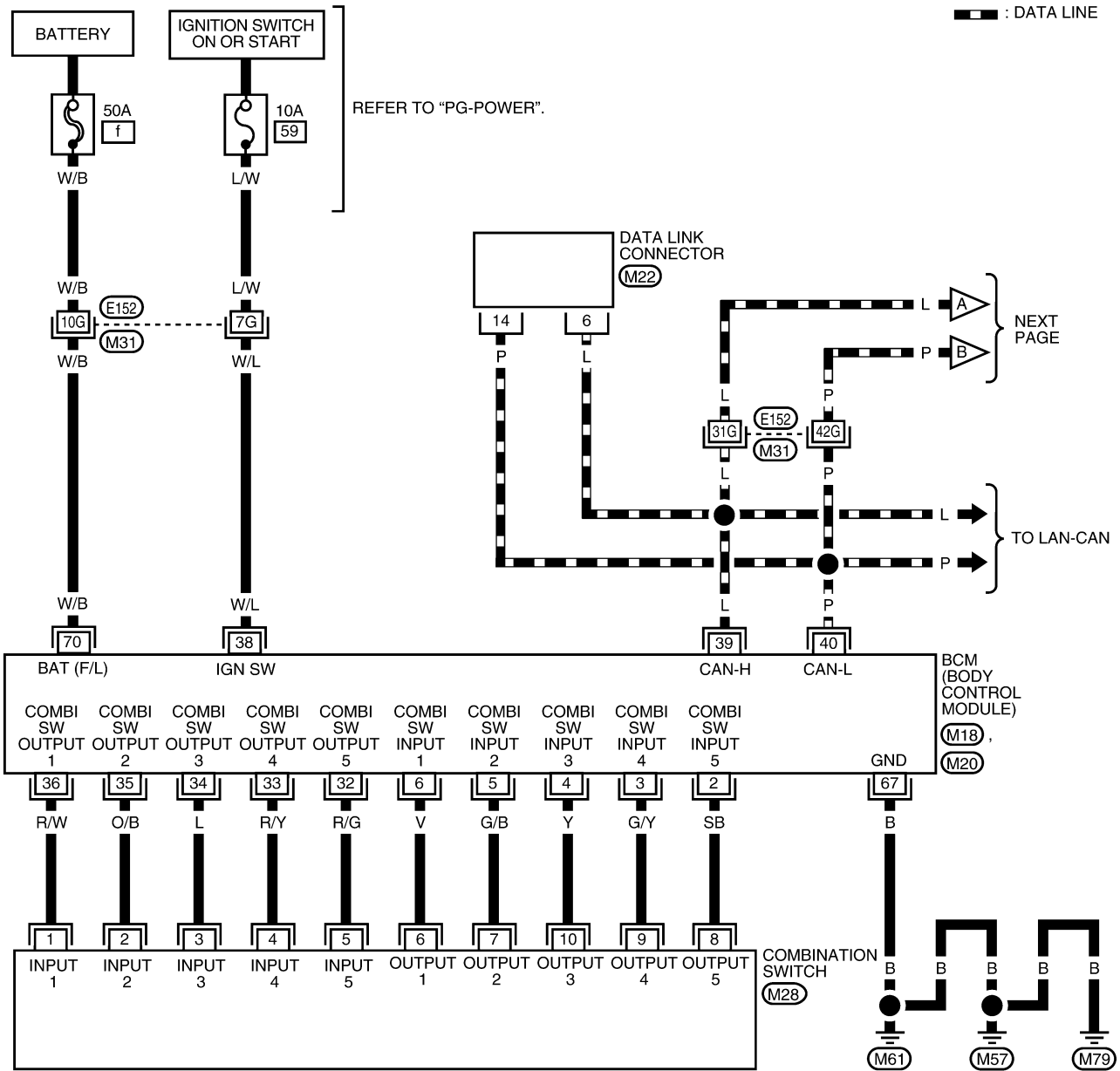

REFER TO THE FOLLOWING.  
 (M31) - SUPER MULTIPLE JUNCTION (SMJ)

WKWA3763E

# FRONT FOG LAMP

LT-F/FOG-02

■ : DATA LINE

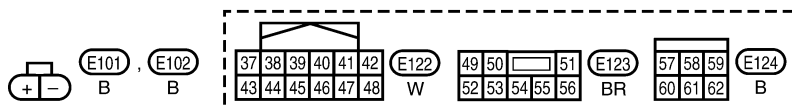
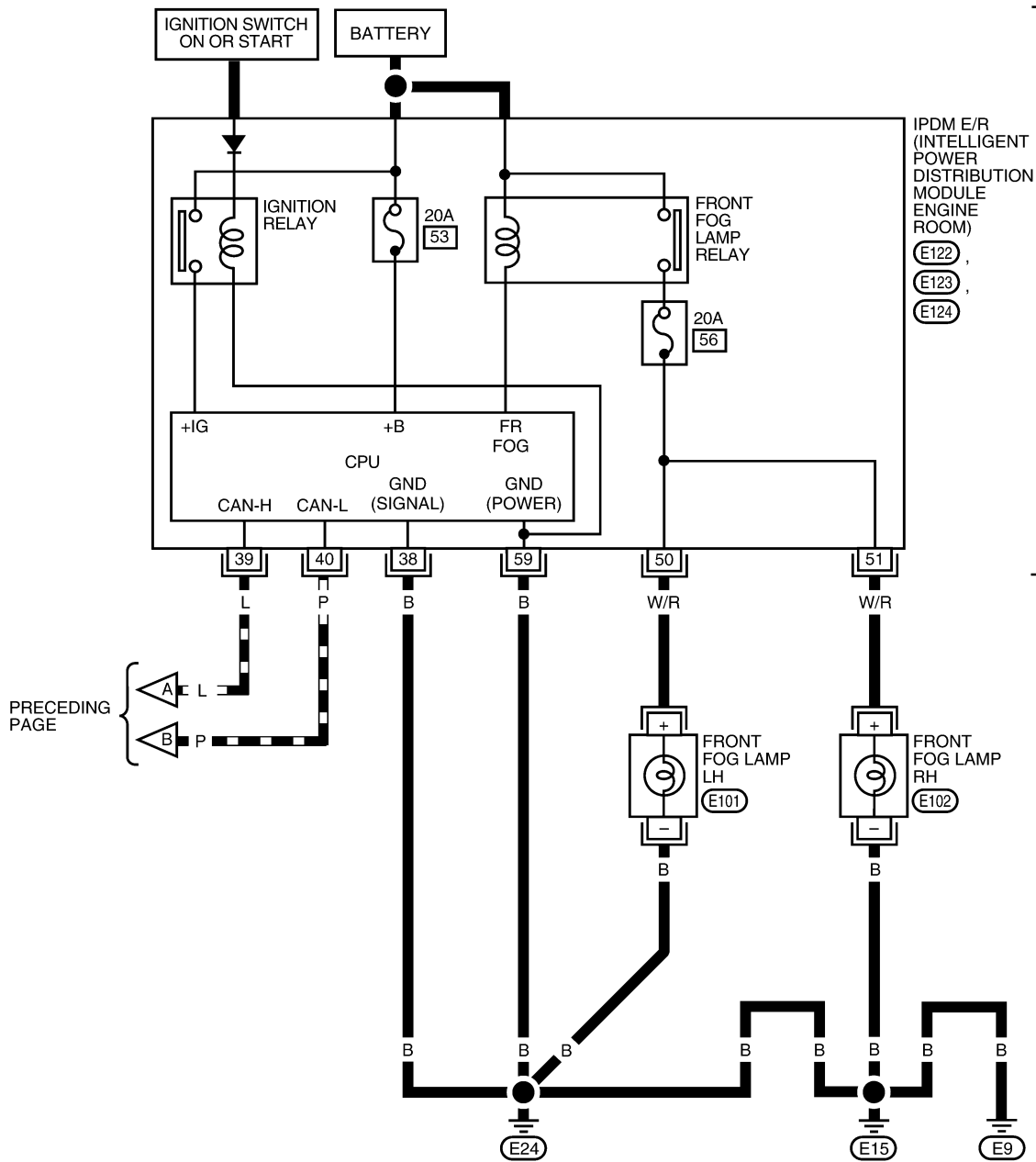

WKWA3764E

# FRONT FOG LAMP

---

## Terminals and Reference Values for BCM

EKS00AAE

Refer to [BCS-12, "Terminals and Reference Values for BCM"](#) .

## Terminals and Reference Values for IPDM E/R

EKS00AAF

Refer to [PG-24, "Terminals and Reference Values for IPDM E/R"](#) .

## How to Proceed With Trouble Diagnosis

EKS00AAG

1. Confirm the symptom or customer complaint.
2. Understand operation description and function description. Refer to [LT-50, "System Description"](#) .
3. Perform the Preliminary Check. Refer to [LT-54, "Preliminary Check"](#) .
4. Check symptom and repair or replace the component.
5. Does the front fog lamp operate normally? If YES: GO TO 6. If NO: GO TO 4.
6. Inspection End.

## Preliminary Check

EKS00AAH

### CHECK BCM CONFIGURATION

#### 1. CHECK BCM CONFIGURATION

---

Confirm BCM configuration for "FR FOG LAMP" is set to "WITH". Refer to [BCS-19, "READ CONFIGURATION PROCEDURE"](#) .

OK or NG

- OK >> Continue preliminary check. Refer to [LT-54, "CHECK POWER SUPPLY AND GROUND CIRCUIT TO BCM"](#) .
- NG >> Change BCM configuration for "FR FOG LAMP" to "WITH". Refer to [BCS-22, "WRITE CONFIGURATION PROCEDURE"](#) .

### CHECK POWER SUPPLY AND GROUND CIRCUIT TO BCM

Refer to [BCS-16, "BCM Power Supply and Ground Circuit Check"](#) .

### CHECK POWER SUPPLY AND GROUND CIRCUIT TO IPDM E/R

Refer to [PG-28, "IPDM E/R Power/Ground Circuit Inspection"](#) .

## CONSULT-II Function (BCM)

EKS00AAI

Refer to [LT-12, "CONSULT-II Function \(BCM\)"](#) .

## CONSULT-II Function (IPDM E/R)

EKS00KYF

Refer to [LT-13, "CONSULT-II Function \(IPDM E/R\)"](#) .

## Front Fog Lamps Do Not Illuminate (Both Sides)

EKS00AAJ

#### 1. INSPECT FOG LAMP FUSE

---

Inspect fog lamp 20A fuse (No. 56, located in IPDM E/R).

OK or NG

- OK >> GO TO 2.
- NG >> Repair short to ground in fog lamp power supply circuit.

# FRONT FOG LAMP

## 2. CHECK COMBINATION SWITCH INPUT SIGNAL

Select "BCM" on CONSULT-II. With "HEAD LAMP" data monitor, make sure "FR FOG SW" turns ON-OFF linked with operation of lighting switch.

**When lighting switch is in FOG position : FR FOG SW ON**

OK or NG

OK >> GO TO 3.

NG >> Check lighting switch. Refer to [LT-77, "Combination Switch Inspection"](#) .

DATA MONITOR	
MONITOR	
FR FOG SW	ON

SKIA5897E

## 3. FOG LAMP ACTIVE TEST

1. Select "IPDM E/R" on CONSULT-II, and select "ACTIVE TEST" on "SELECT DIAG MODE" screen.
2. Select "EXTERNAL LAMPS" on "SELECT TEST ITEM" screen.
3. Touch "FOG" on "ACTIVE TEST" screen.
4. Make sure fog lamps operate.

**Fog lamps should operate.**

OK or NG

OK >> GO TO 4.

NG >> GO TO 5.

ACTIVE TEST			
EXTERNAL LAMPS		OFF	
		TAIL	
LO		HI	
FOG			
MODE	BACK	LIGHT	COPY

WKIA1438E

## 4. CHECK IPDM E/R

1. Select "IPDM E/R" on CONSULT-II, and select "DATA MONITOR" on "SELECT DIAG MODE" screen.
2. Make sure "FR FOG REQ" turns ON when lighting switch is in FOG position.

**When lighting switch is in FOG position : FR FOG REQ ON**

OK or NG

OK >> Replace IPDM E/R. Refer to [PG-30, "Removal and Installation of IPDM E/R"](#) .

NG >> Replace BCM. Refer to [BCS-26, "BCM"](#) .

DATA MONITOR			
MONITOR			
FR FOG REQ	ON		
Page Down			
RECORD			
MODE	BACK	LIGHT	COPY

SKIA5898E

## 5. IPDM E/R INSPECTION

1. Disconnect left/right front fog lamp connectors.
2. Start auto active test. Refer to [PG-22, "Auto Active Test"](#) . When front fog lamp relay is operating, check voltage between left/right front fog lamp connector terminals and ground.

Front fog lamp (+)		(-)	voltage (Approx.)
Connector	Terminal		
LH	E101	+	Ground
RH	E102		
			Battery voltage

OK or NG

OK >> Check front fog lamp bulbs and replace as necessary.

NG >> Replace IPDM E/R. Refer to [PG-30, "Removal and Installation of IPDM E/R"](#) .

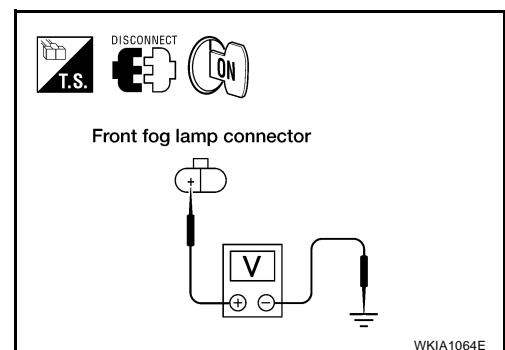

# FRONT FOG LAMP

EKS00AAK

## Front Fog Lamp Does Not Illuminate (One Side)

### 1. BULB INSPECTION

Inspect bulbs of lamps which do not illuminate. Refer to [LT-145, "Exterior Lamp"](#) .

OK or NG

OK >> GO TO 2.

NG >> Replace lamp bulb. Refer to [LT-58, "Bulb Replacement"](#) .

### 2. INSPECTION BETWEEN IPDM E/R AND FRONT FOG LAMPS

1. Disconnect IPDM E/R connector and inoperative front fog lamp connector.
2. Check continuity between harness connector terminals of IPDM E/R and harness connector terminal of front fog lamps.

IPDM E/R		Front fog lamp		Continuity
Connector	Terminal (wire color)	Connector	Terminal (wire color)	
E123	50 (W/R)	LH	E101	+
	51 (W/R)	RH	E102	
				Yes

OK or NG

OK >> Check ground circuit. If OK, replace IPDM E/R. Refer to [PG-30, "Removal and Installation of IPDM E/R"](#) . If NG, repair harness or connector.

NG >> Check for short circuits and open circuits in harness between IPDM E/R and front fog lamps.

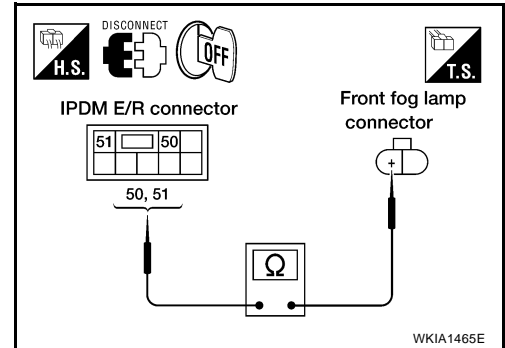



# FRONT FOG LAMP

EKS00AAL

## Aiming Adjustment

The fog lamp is a semi-sealed beam type which uses a replaceable halogen bulb. Before performing aiming adjustment, make sure of the following.

- Keep all tires inflated to correct pressure.
- Place vehicle on level ground.
- See that vehicle is unloaded (except for full levels of coolant, engine oil and fuel, and spare tire, jack, and tools). Have the driver or equivalent weight placed in driver seat.

Adjust aiming in the vertical direction by turning the adjustment screw.

### NOTE:

Access adjustment screw from underneath front bumper. Use a T-3 (3 mm) Torx® bit or a 3 mm allen wrench to adjust. Turn screw clockwise to raise pattern and counterclockwise to lower pattern.

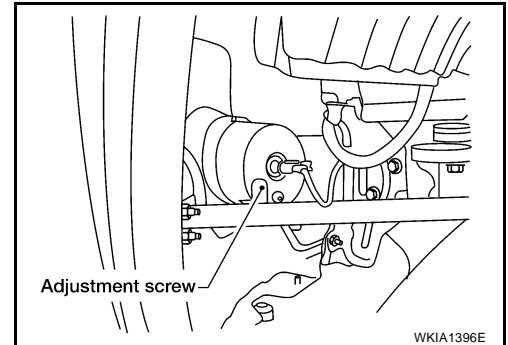

1. Set the distance between the screen and the center of the fog lamp lens as shown.
2. Turn front fog lamps ON.

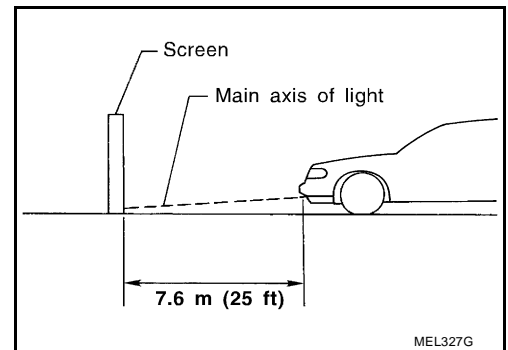

3. Adjust front fog lamps using adjusting screw so that the top edge of the high intensity zone is 100 mm (4 in) below the height of the fog lamp centers as shown.
- When performing adjustment, if necessary, cover the headlamps and opposite fog lamp.

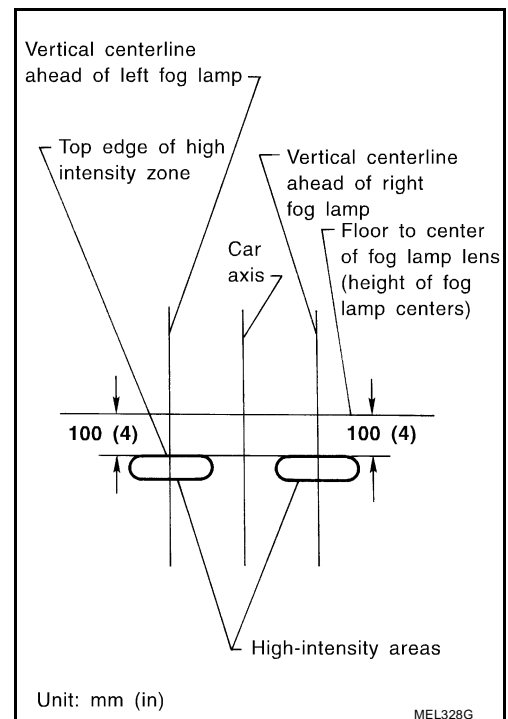

A  
B  
C  
D  
E  
F  
G  
H  
I  
J  
LT  
L  
M

# FRONT FOG LAMP

## Bulb Replacement REMOVAL

EKS00AAM

1. Disconnect electrical connector.
2. Turn the bulb counterclockwise to remove it.

### CAUTION:

- Do not touch the glass of bulb directly by hand. Keep grease and other oily substances away from it. Do not touch bulb by hand while it is lit or right after being turned off. Burning may result.
- Do not leave bulb out of fog lamp reflector for a long time because dust, moisture smoke, etc. may affect the performance of fog lamp. When replacing bulb, be sure to replace it with new one.

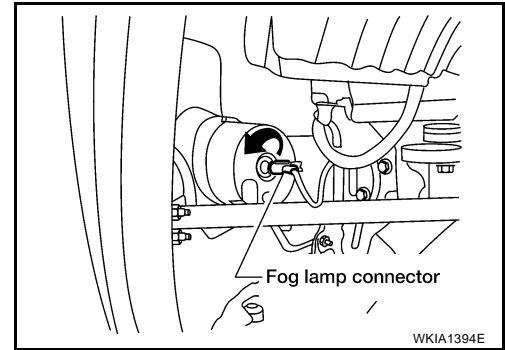

## INSTALLATION

Installation is in the reverse order of removal.

## Removal and Installation

EKS00AAN

The fog lamp is a semi-sealed beam type which uses a replaceable halogen bulb.

### CAUTION:

- Do not leave fog lamp assembly without bulb for a long period of time. Dust, moisture, smoke, etc. entering the fog lamp body may affect the performance. Remove the bulb from the headlamp assembly just before replacement bulb is installed.
- Grasp only the plastic base when handling the bulb. Never touch the glass envelope. Touching the glass could significantly affect the bulb life and/or fog lamp performance.

## REMOVAL

1. Position the fender protector aside.
2. Disconnect electrical connector.
3. Remove nut and pull fog lamp out of front fascia.

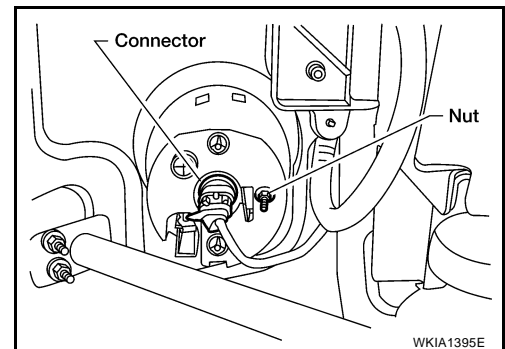

## INSTALLATION

Installation is in the reverse order of removal.

# TURN SIGNAL AND HAZARD WARNING LAMPS

## TURN SIGNAL AND HAZARD WARNING LAMPS

PFP:26120

### Component Parts and Harness Connector Location

EKS00JBI

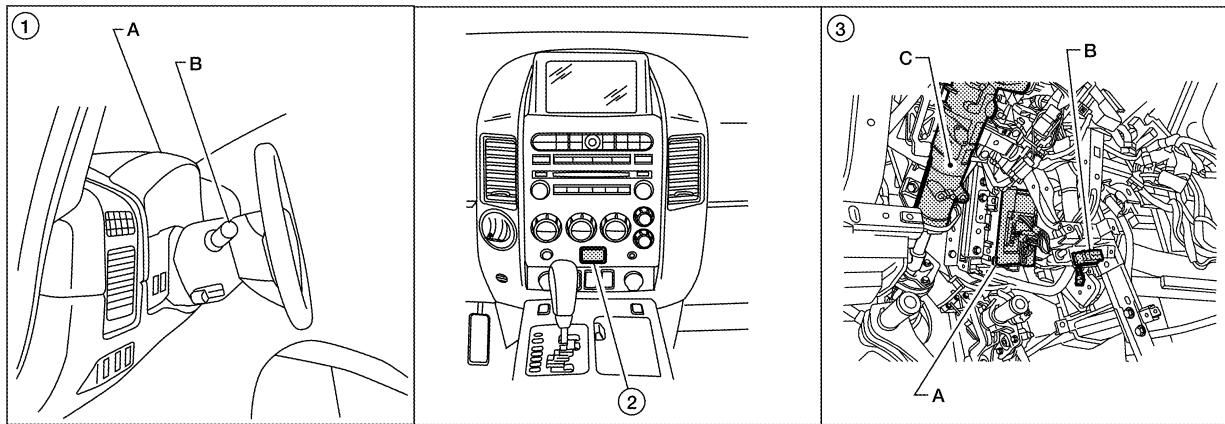

1. A. Combination meter M24  
B. Combination switch M28

2. Hazard switch M55

3. A. BCM M18 and M20  
B. Data link connector M22  
C. Steering column (view with instrument lower panel LH removed)

WKIA5596E

### System Description OUTLINE

EKS00JBJ

Power is supplied at all times

- through 50A fusible link (letter f , located in the fuse and fusible link box)
- to BCM (body control module) terminal 70, and
- through 10A fuse [No. 19, located in the fuse block (J/B)]
- to combination meter terminal 8.

### TURN SIGNAL OPERATION

When the ignition switch is in the ON or START position, power is supplied

- through 10A fuse (No. 59, located in the fuse and relay box)
- to BCM terminal 38, and
- through 10A fuse [No. 14, located in the fuse block (J/B)]
- to combination meter terminal 24.

Ground is supplied

- to BCM terminal 67 and
- to combination meter terminal 17
- through grounds M57, M61 and M79.

### LH Turn

When the turn signal switch is moved to the left position, the BCM, interpreting it as turn signal is ON, outputs turn signal from BCM terminal 60.

The BCM supplies power

- through BCM terminal 60
- to front combination lamp LH terminal 5
- to rear combination lamp LH terminal 8, and
- to door mirror LH terminal 15.

Ground is supplied

- to front combination lamp LH terminal 4
- to rear combination lamp LH terminal 1

A  
B  
C  
D  
E  
F  
G  
H  
I  
J  
LT  
L  
M

# TURN SIGNAL AND HAZARD WARNING LAMPS

---

- through grounds E9, E15 and E24, and
- to door mirror LH terminal 11
- through grounds E57, E61 and E79.

BCM sends signal to combination meter through CAN communication lines, and turns on turn signal indicator lamp within combination meter.

## **RH Turn**

When the turn signal switch is moved to the right position, the BCM, interpreting it as turn signal is ON, outputs turn signal from BCM terminal 61.

The BCM supplies power

- through BCM terminal 61
- to front combination lamp RH terminal 5
- to rear combination lamp RH terminal 8
- to door mirror RH terminal 15.

Ground is supplied

- to front combination lamp RH terminal 4
- to rear combination lamp RH terminal 1
- through grounds E9, E15 and E24, and
- to door mirror RH terminal 11
- through grounds M57, M61, and M79.

BCM sends signal to combination meter through CAN communication lines, and turns on turn signal indicator lamp within combination meter.

## **HAZARD LAMP OPERATION**

Power is supplied at all times

- through 50A fusible link (letter f , located in the fuse and fusible link box)
- to BCM terminal 70, and
- through 10A fuse [No. 19, located in the fuse block (J/B)]
- to combination meter terminal 8.

Ground is supplied

- to BCM terminal 67 and
- to combination meter terminal 17
- through grounds M57, M61 and M79.

When the hazard switch is depressed, ground is supplied

- to BCM terminal 29
- through hazard switch terminal 4
- through hazard switch terminal 6
- through grounds M57, M61 and M79.

When the hazard switch is depressed, the BCM, interpreting it as turn signal is ON, outputs turn signal from BCM terminals 60 and 61.

The BCM supplies power

- through BCM terminals 60 and 61
- to front combination lamp LH and RH terminal 5
- to rear combination lamp LH and RH terminal 8
- to door mirror LH and RH terminal 15.

Ground is supplied

- to front combination lamp LH and RH terminal 4
- to rear combination lamp LH and RH terminal 1
- through grounds E9, E15 and E24, and
- to door mirror LH and RH terminal 11
- through grounds M57, M61, and M79.

# TURN SIGNAL AND HAZARD WARNING LAMPS

BCM sends signal to combination meter through CAN communication lines, and turns on turn signal indicator lamps within combination meter.

A

## REMOTE KEYLESS ENTRY SYSTEM OPERATION

Power is supplied at all times

- through 50A fusible link (letter f , located in the fuse and fusible link box)
- to BCM terminal 70, and
- through 10A fuse [No. 19, located in the fuse block (J/B)]
- to combination meter terminal 8.

B

Ground is supplied

- to BCM terminal 67 and
- to combination meter terminal 17
- through grounds M57, M61 and M79.

C

D

When the remote keyless entry system is triggered by input from the keyfob, the BCM, interpreting it as turn signal is ON, outputs turn signal from BCM terminals 60 and 61.

E

The BCM supplies power

- through BCM terminals 60 and 61
- to front combination lamp LH and RH terminal 5
- to rear combination lamp LH and RH terminal 8
- to door mirror LH and RH terminal 15.

F

Ground is supplied

- to front combination lamp LH and RH terminal 4
- to rear combination lamp LH and RH terminal 1
- through grounds E9, E15 and E24, and
- to door mirror LH and RH terminal 11
- through grounds M57, M61, and M79.

G

H

I

BCM sends signal to combination meter through CAN communication lines, and turns on turn signal indicator lamps within combination meter.

J

With power and input supplied, the BCM controls the flashing of the hazard warning lamps when keyfob is used to activate the remote keyless entry system.

## COMBINATION SWITCH READING FUNCTION

Refer to [BCS-3, "COMBINATION SWITCH READING FUNCTION"](#) .

LT

## CAN Communication System Description

Refer to [LAN-2, "CAN Communication System"](#) .

EKS00J8K

L

M

# TURN SIGNAL AND HAZARD WARNING LAMPS

## Schematic

EKS00J8L

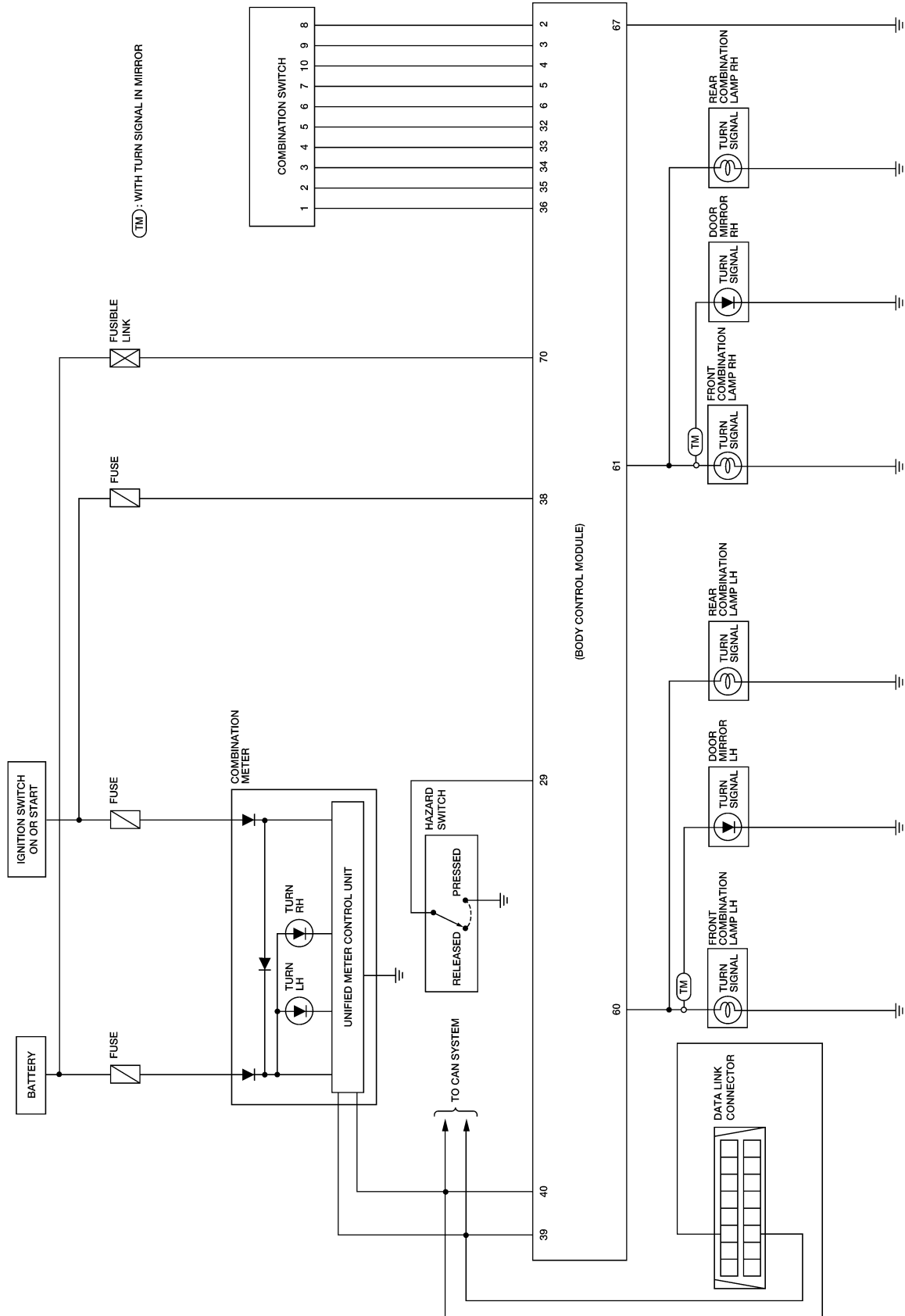

WKWA3811E

# TURN SIGNAL AND HAZARD WARNING LAMPS

## Wiring Diagram — TURN —

EKS00J8M

LT-TURN-01

— : DATA LINE

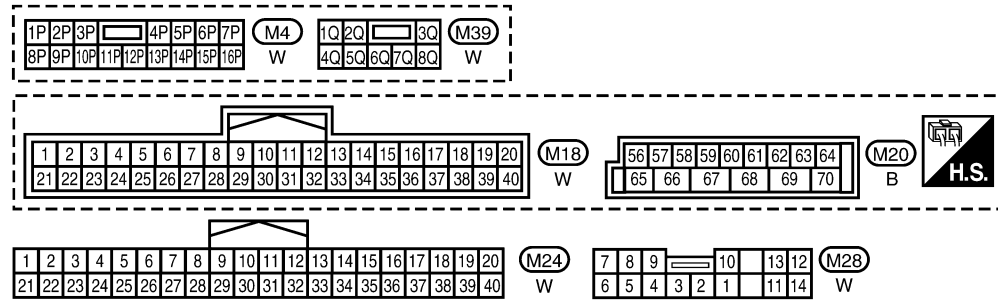
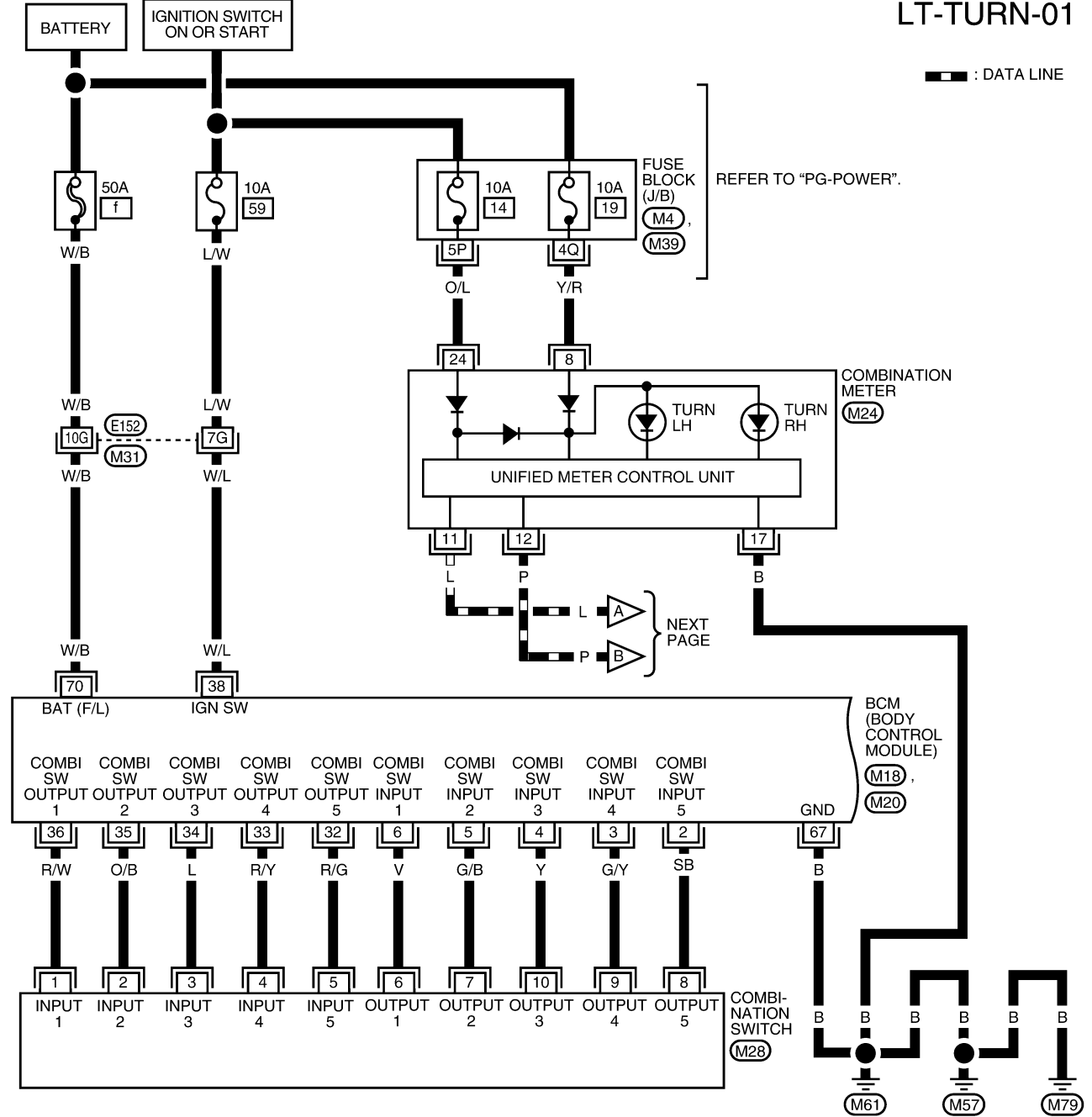

WKWA3765E

# TURN SIGNAL AND HAZARD WARNING LAMPS

## LT-TURN-02

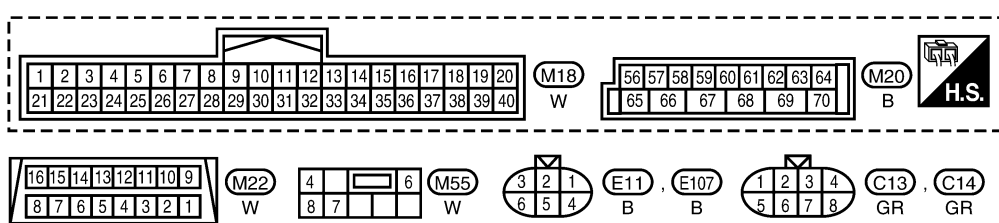
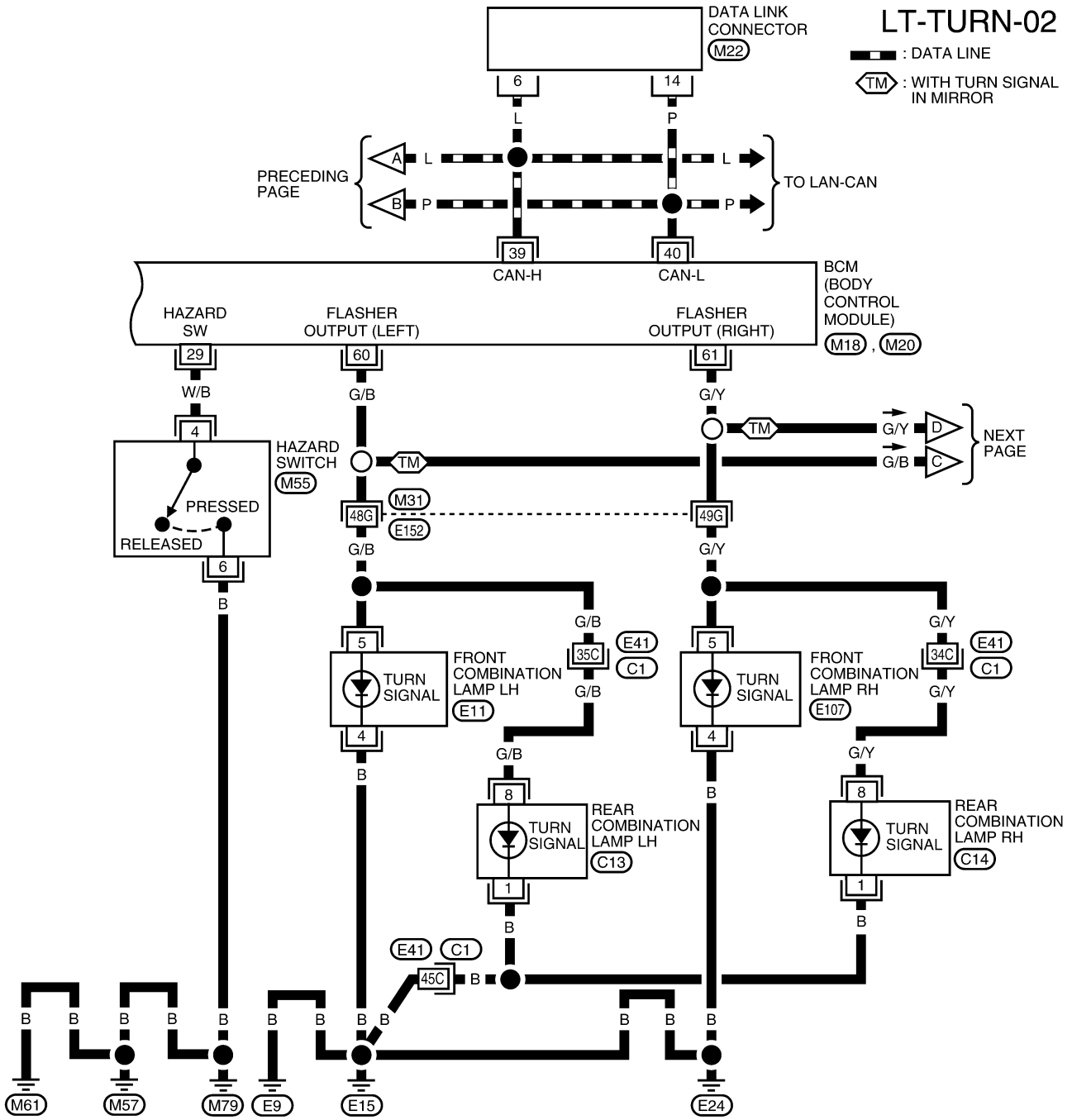

REFER TO THE FOLLOWING.  
**(M31)** - SUPER MULTIPLE JUNCTION (SMJ)



# TURN SIGNAL AND HAZARD WARNING LAMPS

LT-TURN-03

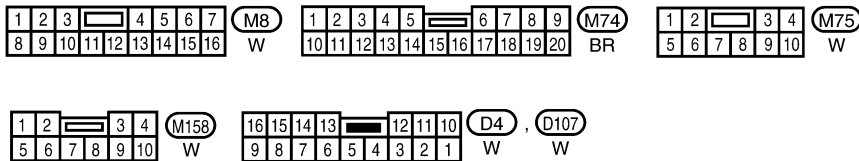
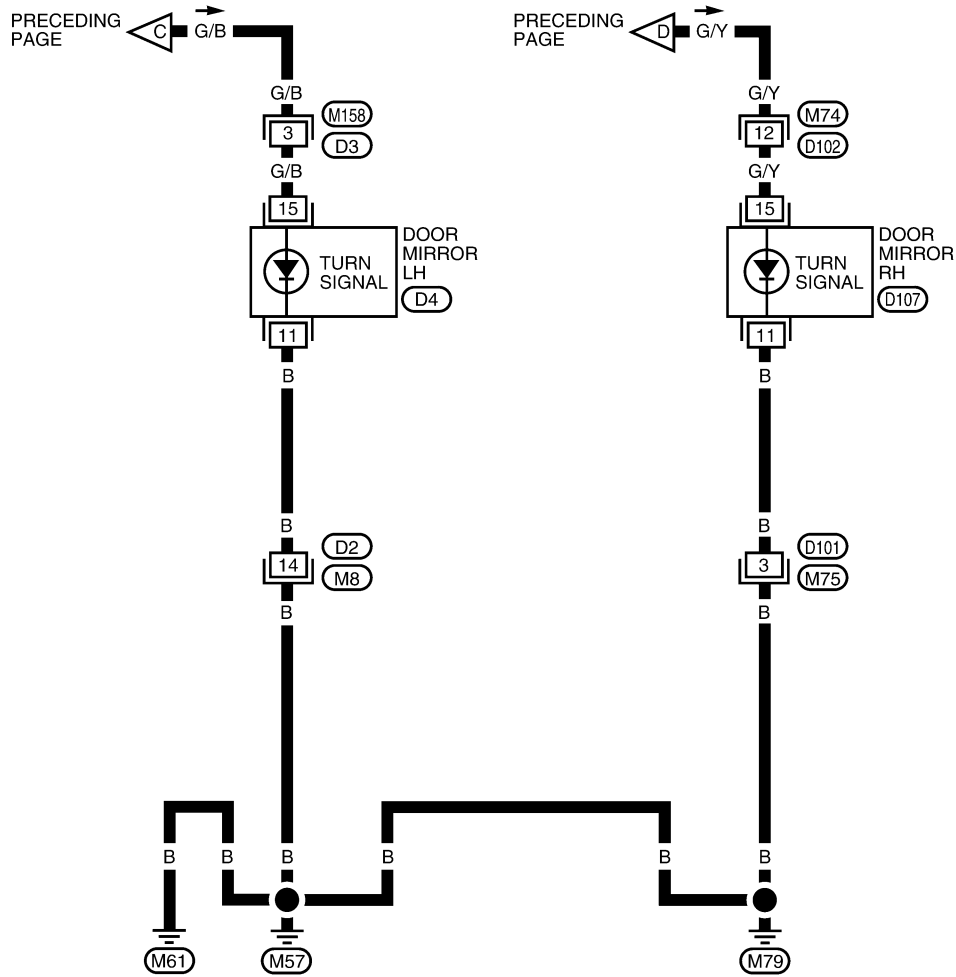

WKWA5154E

# TURN SIGNAL AND HAZARD WARNING LAMPS

## Terminals and Reference Values for BCM

EKS00J8N

Refer to [BCS-12, "Terminals and Reference Values for BCM"](#) .

## How to Proceed With Trouble Diagnosis

EKS00J8O

1. Confirm the symptom or customer complaint.
2. Understand operation description and function description. Refer to [LT-59, "System Description"](#) .
3. Perform preliminary check.
4. Check symptom and repair or replace the component.
5. Do turn signal and hazard warning lamps operate normally? If YES: GO TO 6. If NO: GO TO 4.
6. Inspection End.

## Preliminary Check

EKS00J8P

### CHECK POWER SUPPLY AND GROUND CIRCUIT TO BCM

Refer to [BCS-16, "BCM Power Supply and Ground Circuit Check"](#) .

## CONSULT-II Function (BCM)

EKS00J8Q

Refer to [BCS-18, "CONSULT-II Function \(BCM\)"](#) .

## CONSULT-II START PROCEDURE

Refer to [GI-38, "CONSULT-II Start Procedure"](#) .

## DATA MONITOR

### Display Item List

Monitor item	Contents
IGN ON SW "ON/OFF"	Displays "IGN position (ON)/OFF, ACC position (OFF)" judged from the ignition switch signal.
HAZARD SW "ON/OFF"	Displays "Hazard ON (ON)/Hazard OFF (OFF)" status, determined from hazard switch signal.
TURN SIGNAL R "ON/OFF"	Displays "Turn right (ON)/Other (OFF)" status, determined from lighting switch signal.
TURN SIGNAL L "ON/OFF"	Displays "Turn left (ON)/Other (OFF)" status, determined from lighting switch signal.
BRAKE SW "ON/OFF"	Displays status of stop lamp switch.

## ACTIVE TEST

### Display Item List

Test item	Description
FLASHER (RH)	Turn signal lamp (right) can be operated by any ON-OFF operations.
FLASHER (LH)	Turn signal lamp (left) can be operated by any ON-OFF operations.

# TURN SIGNAL AND HAZARD WARNING LAMPS

EKS00J8R

## Turn Signals Do Not Operate

### 1. CHECK COMBINATION SWITCH INPUT SIGNAL

④ With CONSULT-II

1. Select "BCM" on CONSULT-II. Select "FLASHER" on "SELECT TEST ITEM" screen.
2. Select "DATA MONITOR" on "SELECT DIAG MODE" screen. Make sure that "TURN SIGNAL R" and "TURN SIGNAL L" turns ON-OFF linked with operation of lighting switch.

**When turn signal switch is : TURN SIGNAL R ON right position**

**When turn signal switch is : TURN SIGNAL L ON left position**

DATA MONITOR			
MONITOR			
TURN SIGNAL R	ON		
TURN SIGNAL L	ON		
RECORD			
MODE	BACK	LIGHT	COPY

PKIA7600E

⊗ Without CONSULT-II

Refer to [LT-77, "Combination Switch Inspection"](#) .

OK or NG

OK >> Replace the BCM. [BCS-26, "BCM"](#) .

NG >> Check combination switch (lighting switch). Refer to [LT-77, "Combination Switch Inspection"](#) .

## Front Turn Signal Lamp Does Not Operate

EKS00J8S

### 1. CHECK BULB

Verify the bulb standard of each turn signal lamp is correct. Refer to [LT-145, "Exterior Lamp"](#) .

OK or NG

OK >> GO TO 2.

NG >> Replace turn signal lamp bulb. Refer to [LT-72, "TURN SIGNAL LAMP \(FRONT\)"](#) .

### 2. CHECK TURN SIGNAL LAMPS CIRCUIT

1. Turn ignition switch OFF.
2. Disconnect BCM connector and front combination lamp LH and RH connectors.
3. Check continuity between BCM harness connector M20 terminal 60 and front combination lamp LH harness connector E11 terminal 5.

**60 - 5 : Continuity should exist.**

4. Check continuity between BCM harness connector M20 terminal 61 and front combination lamp RH harness connector E107 terminal 5.

**61 - 5 : Continuity should exist.**

OK or NG

OK >> GO TO 3.

NG >> Repair harness or connector.

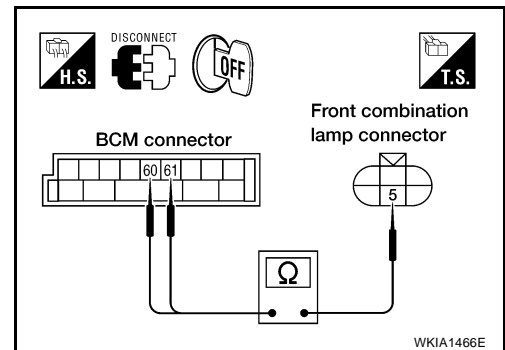

# TURN SIGNAL AND HAZARD WARNING LAMPS

## 3. CHECK GROUND CIRCUIT

1. Check continuity between front combination lamp LH harness connector E11 terminal 4 and ground.

**4 - Ground : Continuity should exist.**

2. Check continuity between front combination lamp RH harness connector E107 terminal 4 and ground.

**4 - Ground : Continuity should exist.**

### OK or NG

- OK >> Inspect connection at front combination lamp.  
NG >> Repair harness.

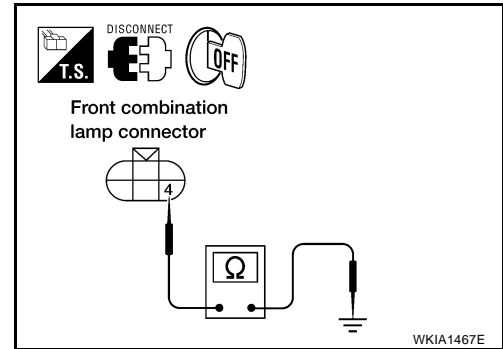

## Door Mirror Turn Signal Lamp Does Not Operate

EKS00JXW

### 1. CHECK TURN SIGNAL LAMPS CIRCUIT

1. Turn ignition switch OFF.
2. Disconnect BCM connector and door mirror LH/RH connector.
3. Check continuity between BCM harness connector M20 (A) terminal 60 and door mirror LH harness connector D4 (B) terminal 15.

**60 - 15 : Continuity should exist.**

4. Check continuity between BCM harness connector M20 (A) terminal 61 and door mirror RH harness connector D107 (B) terminal 15.

**61 - 15 : Continuity should exist.**

### OK or NG

- OK >> GO TO 2.  
NG >> Repair harness or connector.

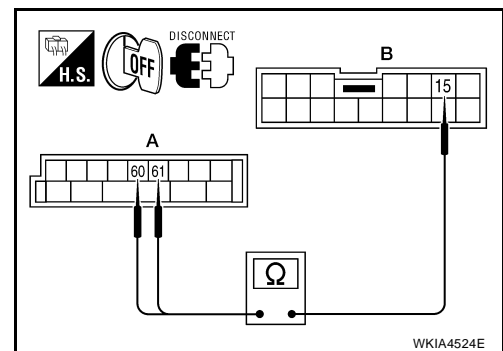

## 2. CHECK GROUND

1. Check continuity between door mirror LH harness connector D4 terminal 11 and ground.

**11 - Ground : Continuity should exist.**

2. Check continuity between door mirror RH harness connector D107 terminal 11 and ground.

**11 - Ground : Continuity should exist.**

### OK or NG

- OK >> Replace door mirror turn signal.  
NG >> Repair harness or connector.

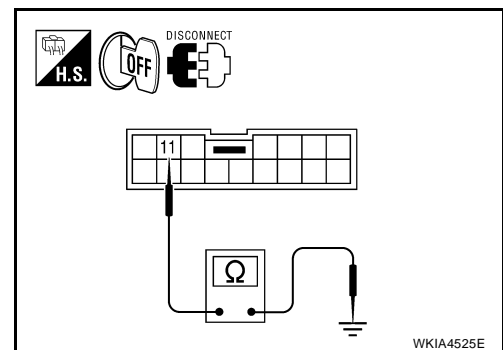

## Rear Turn Signal Lamp Does Not Operate

EKS00J8T

### 1. CHECK BULB

Verify the bulb standard of each turn signal lamp is correct. Refer to [LT-145. "Exterior Lamp"](#) .

### OK or NG

- OK >> GO TO 2.  
NG >> Replace turn signal lamp bulb. Refer to [LT-72. "TURN SIGNAL LAMP \(REAR\)"](#) .

# TURN SIGNAL AND HAZARD WARNING LAMPS

## 2. CHECK REAR TURN SIGNAL LAMP CIRCUIT

1. Turn ignition switch OFF.
2. Disconnect BCM connector and rear combination lamp LH or RH connector.
3. Check continuity between BCM harness connector M20 (A) terminal 60 and rear combination lamp LH harness connector C13 (B) terminal 8.

**60 - 8** : Continuity should exist.

4. Check continuity between BCM harness connector M20 (A) terminal 61 and rear combination lamp RH harness connector C14 (B) terminal 8.

**61 - 8** : Continuity should exist.

OK or NG

OK >> GO TO 3.

NG >> Repair harness or connector.

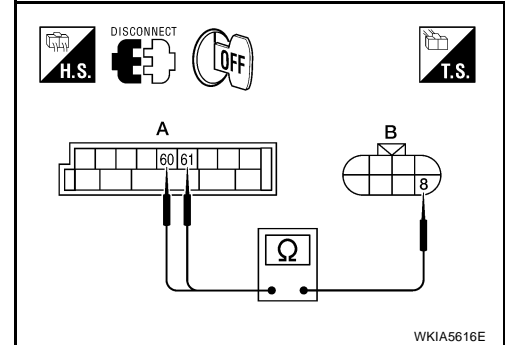

## 3. CHECK GROUND CIRCUIT

1. Check continuity between rear combination lamp LH harness connector C13 terminal 1 and ground.

**1 - Ground** : Continuity should exist.

2. Check continuity between rear combination lamp RH harness connector C14 terminal 1 and ground.

**1 - Ground** : Continuity should exist.

OK or NG

OK >> Check rear combination lamp connector for proper connection. Repair as necessary.

NG >> Repair harness or connector.

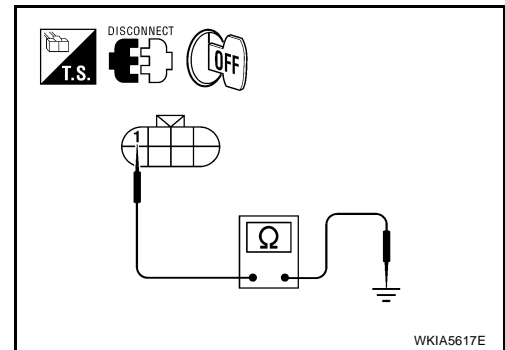

A  
B  
C  
D  
E  
F  
G  
H  
I  
J  
LT  
L  
M

# TURN SIGNAL AND HAZARD WARNING LAMPS

EKS00J8U

## Hazard Warning Lamp Does Not Operate But Turn Signal Lamp Operates

### 1. CHECK HAZARD SWITCH INPUT SIGNAL

① With CONSULT-II

1. Select "BCM" on CONSULT-II. Select "FLASHER" on "SELECT TEST ITEM" screen.
2. Select "DATA MONITOR" on "SELECT DIAG MODE" screen. Make sure that "HAZARD SW" turns ON-OFF linked with operation of hazard switch.

**When hazard switch is in ON position : HAZARD SW ON**

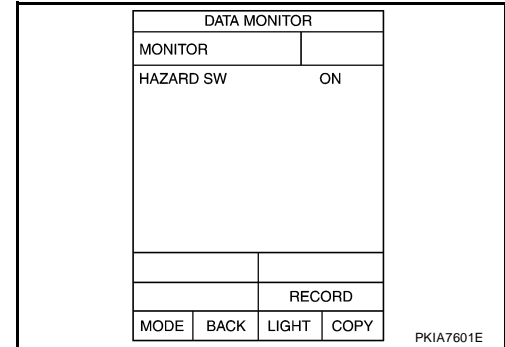

⊗ Without CONSULT-II

Check voltage between BCM harness connector and ground.

Terminal (+)		Terminal (-)	Condition	Voltage
BCM connector	Terminal			
M18	29	Ground	Hazard switch is ON	0V
			Hazard switch is OFF	Battery voltage

OK or NG

- OK >> Replace BCM. Refer to [BCS-26, "BCM"](#) .
- NG >> GO TO 2.

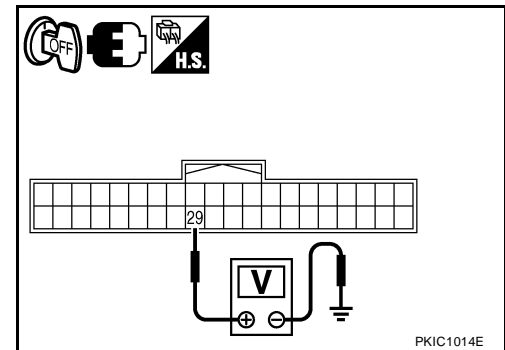

### 2. CHECK HAZARD SWITCH CIRCUIT

1. Turn ignition switch OFF.
2. Disconnect BCM connector and hazard switch connector.
3. Check continuity BCM harness connector M18 and hazard switch harness connector M55.

A		B		Continuity
Connector	Terminal	Connector	Terminal	
M18	29	M55	4	Yes

OK or NG

- OK >> GO TO 3.
- NG >> Repair harness or connector.

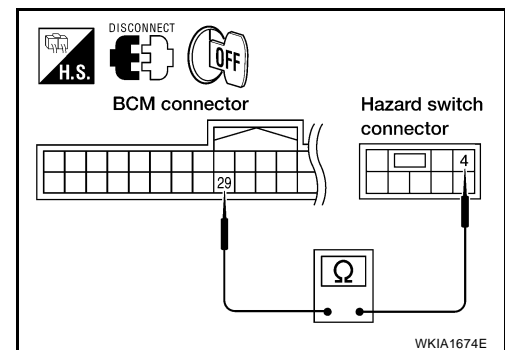

### 3. CHECK GROUND CIRCUIT

Check continuity between hazard switch harness connector M55 terminal 6 and ground.

**6 – Ground : Continuity should exist.**

OK or NG

- OK >> GO TO 4.
- NG >> Repair harness or connector.

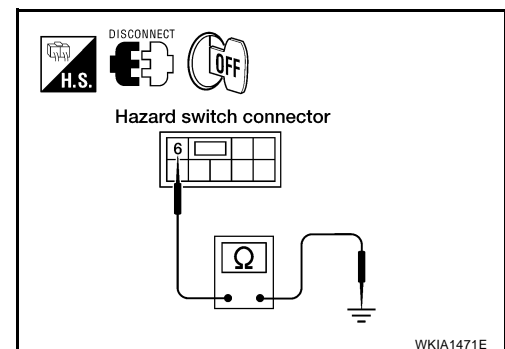

# TURN SIGNAL AND HAZARD WARNING LAMPS

## 4. CHECK HAZARD SWITCH

1. Disconnect hazard switch connector.
2. Check continuity hazard switch terminals.

Terminal		Condition	Continuity
Hazard switch			
4	6	Hazard switch is ON	Yes
		Hazard switch is OFF	No

### OK or NG

OK >> Replace BCM if hazard warning lamps do not operate after setting the connector again. Refer to [BCS-26, "BCM"](#).

NG >> Replace hazard switch.

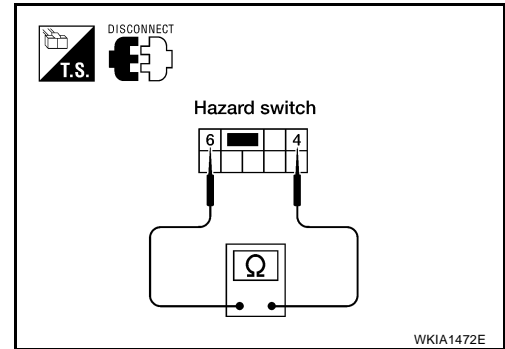

## Turn Signal Indicator Lamp Does Not Operate

EKS00J8V

### 1. CHECK CAN COMMUNICATION SYSTEM

Check CAN communication. Refer to [LAN-2, "CAN Communication System"](#).

### OK or NG

OK >> Replace combination meter. Refer to [DI-22, "Removal and Installation of Combination Meter"](#).

NG >> Repair as necessary.

A  
B  
C  
D  
E  
F  
G  
H  
I  
J  
LT  
L  
M

# TURN SIGNAL AND HAZARD WARNING LAMPS

---

## **Bulb Replacement**

EKS00J91

### **TURN SIGNAL LAMP (FRONT)**

Refer to [LT-25, "TURN SIGNAL/PARKING LAMP \(FRONT\)"](#) .

### **TURN SIGNAL LAMP (REAR)**

Refer to [LT-98, "Bulb Replacement"](#) .

## **Removal and Installation**

EKS00J92

### **TURN SIGNAL LAMP (FRONT)**

Refer to [LT-25, "TURN SIGNAL/PARKING LAMP \(FRONT\)"](#) .

### **TURN SIGNAL LAMP (REAR)**

Refer to [LT-98, "Removal and Installation"](#) .



# LIGHTING AND TURN SIGNAL SWITCH

## LIGHTING AND TURN SIGNAL SWITCH

PFP:25540

### Removal and Installation

EKS00AB4

#### REMOVAL

1. Remove steering column cover.
2. While pressing tabs, pull lighting and turn signal switch toward driver door and disconnect from the base.

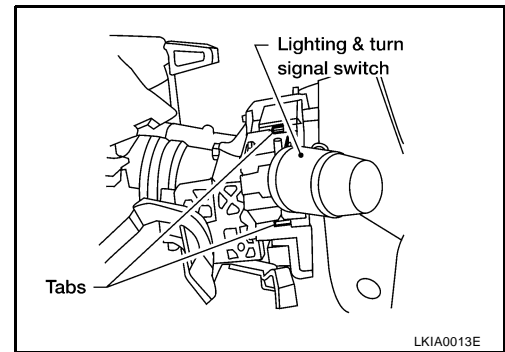

#### INSTALLATION

Installation is in the reverse order of removal.

A  
B  
C  
D  
E  
F  
G  
H  
I  
J  
LT  
L  
M

# HAZARD SWITCH

## HAZARD SWITCH

PFP:25290

### Removal and Installation

EKS00AB5

#### REMOVAL

1. Remove cluster lid C. Refer to [IP-12, "CLUSTER LID C"](#) .
2. While pressing the tab, push out the hazard switch.

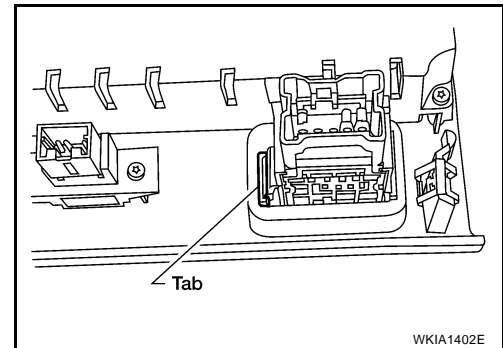

#### INSTALLATION

Installation is in the reverse order of removal.

# COMBINATION SWITCH

## COMBINATION SWITCH

PF25:25567

### Wiring Diagram — COMBSW —

EKS00AB6

### LT-COMBSW-01

▬ : DATA LINE

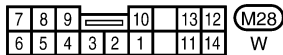
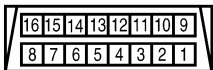
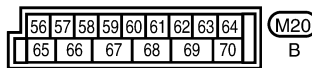
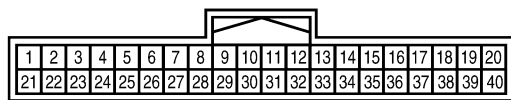
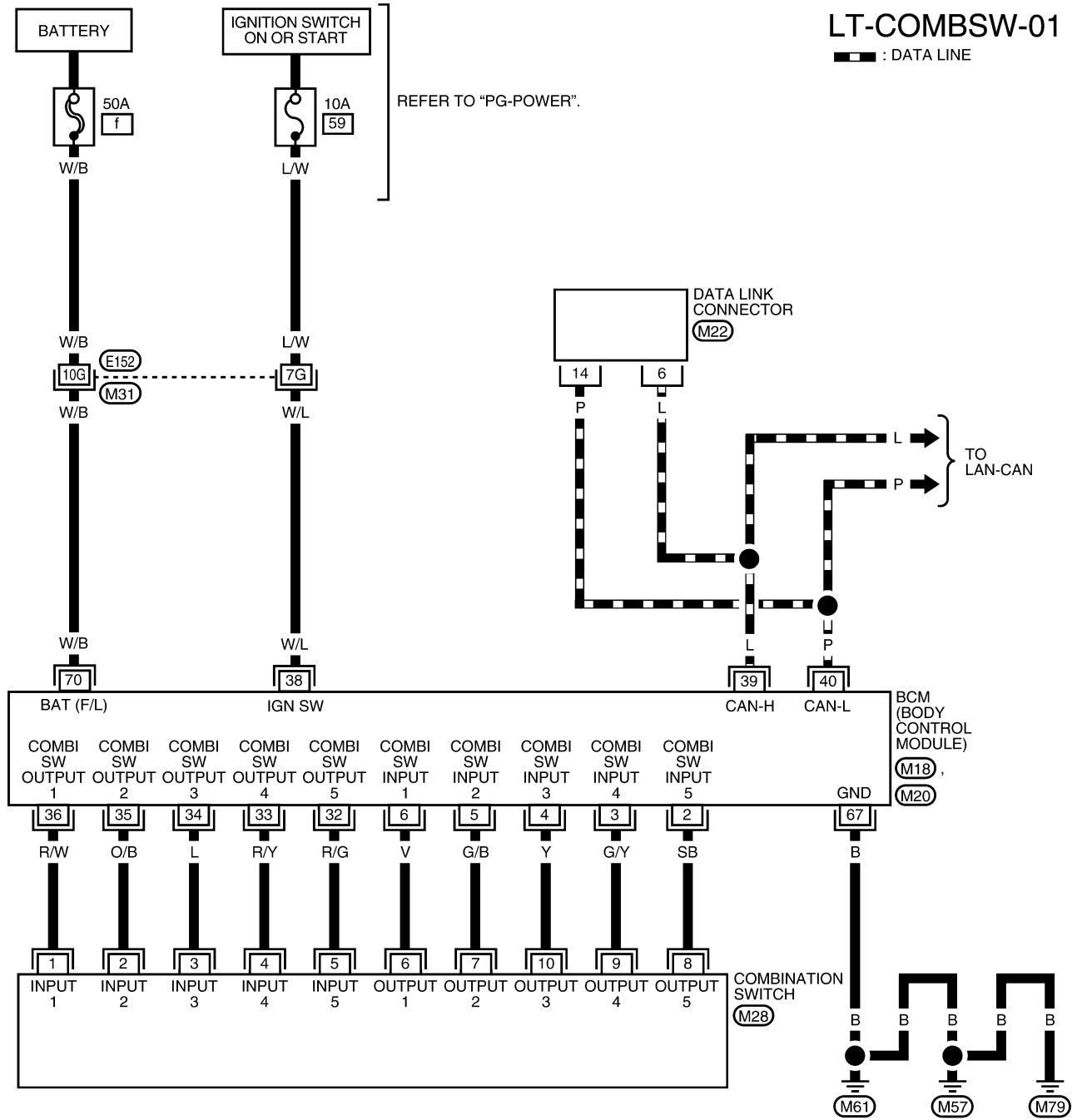

REFER TO THE FOLLOWING.  
 (M31) - SUPER MULTIPLE JUNCTION (SMJ)

# COMBINATION SWITCH

## Combination Switch Reading Function

EKS00AB7

For details, refer to [BCS-3, "COMBINATION SWITCH READING FUNCTION"](#) .

## CONSULT-II Function (BCM)

EKS00AB8

Refer to [BCS-26, "BCM"](#) .

## CONSULT-II START PROCEDURE

Refer to [GI-38, "CONSULT-II Start Procedure"](#) .

## DATA MONITOR

### Display Item List

Monitor item name "OPERATION OR UNIT"	Contents
TURN SIGNAL R "ON/OFF"	Displays "Turn Right (ON)/Other (OFF)" status, determined from lighting switch signal.
TURN SIGNAL L "ON/OFF"	Displays "Turn Left (ON)/Other (OFF)" status, determined from lighting switch signal.
HI BEAM SW "ON/OFF"	Displays status (high beam switch: ON/Others: OFF) of high beam switch judged from lighting switch signal.
HEAD LAMP SW 1 "ON/OFF"	Displays "Headlamp switch 1 (ON)/Other (OFF)" status, determined from lighting switch signal.
HEAD LAMP SW 2 "ON/OFF"	Displays status (headlamp switch 2: ON/Others: OFF) of headlamp switch 2 judged from lighting switch signal.
LIGHT SW 1ST "ON/OFF"	Displays status (lighting switch 1st position: ON/Others: OFF) of lighting switch judged from lighting switch signal.
PASSING SW "ON/OFF"	Displays status (flash-to-pass switch: ON/Others: OFF) of flash-to-pass switch judged from lighting switch signal.
AUTO LIGHT SW "ON/OFF"	Displays "Auto light switch (ON)/Other (OFF)" status, determined from lighting switch signal.
FR FOG SW "ON/OFF"	Displays "Front fog lamp switch (ON)/Other (OFF)" status, determined from lighting switch signal.
FR WIPER HI "ON/OFF"	Displays "Front Wiper HI (ON)/Other (OFF)" status, determined from wiper switch signal.
FR WIPER LOW "ON/OFF"	Displays "Front Wiper LOW (ON)/Other (OFF)" status, determined from wiper switch signal.
FR WIPER INT "ON/OFF"	Displays "Front Wiper INT (ON)/Other (OFF)" status, determined from wiper switch signal.
FR WASHER SW "ON/OFF"	Displays "Front Washer Switch (ON)/Other (OFF)" status, determined from wiper switch signal.
INT VOLUME [1 - 7]	Displays intermittent operation knob setting (1 - 7), determined from wiper switch signal.

# COMBINATION SWITCH

EKS00AB9

## Combination Switch Inspection

### 1. SYSTEM CHECK

Referring to table below, check to which system the malfunctioning switch belongs.

System 1	System 2	System 3	System 4	System 5
—	FR WASHER	FR WIPER LO	TURN LH	TURN RH
FR WIPER HI	—	FR WIPER INT	PASSING	HEAD LAMP1
INT VOLUME 1	—	—	HEAD LAMP2	HI BEAM
—	INT VOLUME 3	AUTO LIGHT	—	TAIL LAMP
INT VOLUME 2	—	—	FR FOG	—

>> GO TO 2.

### 2. SYSTEM CHECK

 With CONSULT-II

#### CAUTION:

If CONSULT-II is used with no connection of CONSULT-II CONVERTER, malfunctions might be detected in self-diagnosis depending on control unit which carries out CAN communication.

1. Connect CONSULT-II, and select "COMB SW" on "SELECT TEST ITEM" screen.
2. Select "DATA MONITOR".
3. Select "START", and confirm that other switches in malfunctioning system operate normally.

Example: When auto light switch is malfunctioning, confirm that "FRONT WIPER LO" and "FRONT WIPER INT" in System 3, to which the auto light switch belongs, turn ON-OFF normally.

DATA MONITOR	
MONITOR	
TURN SIGNAL R	OFF
TURN SIGNAL L	OFF
HIBEAM SW	OFF
HEAD LAMP SW1	OFF
HEAD LAMP SW2	OFF
LIGHT SW 1ST	OFF
PASSING SW	OFF
AUTO LIGHT SW	OFF
FR FOG SW	OFF
	Page Down
	RECORD
MODE	BACK
LIGHT	COPY

SKIA7075E

 Without CONSULT-II

Operate combination switch, and confirm that other switches in malfunctioning system operate normally.

Example: When auto light switch is malfunctioning, confirm that "FRONT WIPER LOW" and "FRONT WIPER INT" in System 3, to which the auto light switch belongs, operate normally.

#### Check results

Other switches in malfunctioning system operate normally.>>Replace lighting switch or wiper switch.

Other switches in malfunctioning system do not operate normally.>>GO TO 3.

# COMBINATION SWITCH

## 3. HARNESS INSPECTION

1. Turn ignition switch OFF.
2. Disconnect BCM and combination switch connectors.
3. Check for continuity between BCM harness connector of the suspect system and the corresponding combination switch connector terminals.

Suspect system	Terminals				Continuity	
	BCM		Combination switch			
	Connector	Terminal	Connector	Terminal		
1	M18	Input 1	6	M28	6	Yes
		Output 1	36		1	
2		Input 2	5		7	
		Output 2	35		2	
3		Input 3	4		10	
		Output 3	34		3	
4		Input 4	3		9	
		Output 4	33		4	
5		Input 5	2		8	
		Output 5	32		5	

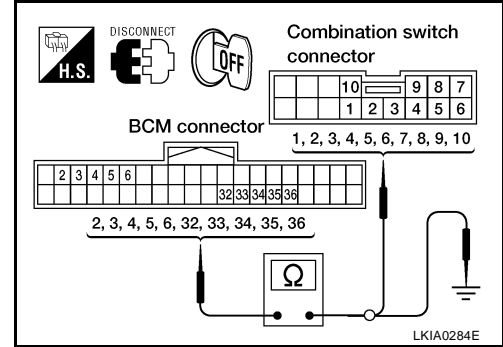

4. Check for continuity between each terminal of BCM harness connector in suspect malfunctioning system and ground.

Suspect system	Terminals				Continuity
	BCM				
	Connector	Terminal			
1	M18	Input 1	6	Ground	No
		Output 1	36		
2		Input 2	5		
		Output 2	35		
3		Input 3	4		
		Output 3	34		
4		Input 4	3		
		Output 4	33		
5		Input 5	2		
		Output 5	32		

OK or NG

OK >> GO TO 4.

NG >> Check harness between BCM and combination switch for open or short circuit.

# COMBINATION SWITCH

## 4. BCM OUTPUT TERMINAL INSPECTION

1. Turn lighting switch and wiper switch to OFF.
2. Set wiper dial to position 4.
3. Turn ignition switch ON.
4. Connect BCM and combination switch connectors
5. Check BCM output terminal voltage waveform of suspect malfunctioning system.

Suspect system	Combination switch (+)	
	Connector	Terminal
1	M28	Input 1
2		Input 2
3		Input 3
4		Input 4
5		Input 5

OK or NG

- OK >> Open circuit in combination switch, GO TO 5.  
 NG >> Replace BCM. Refer to [BCS-26, "BCM"](#) .

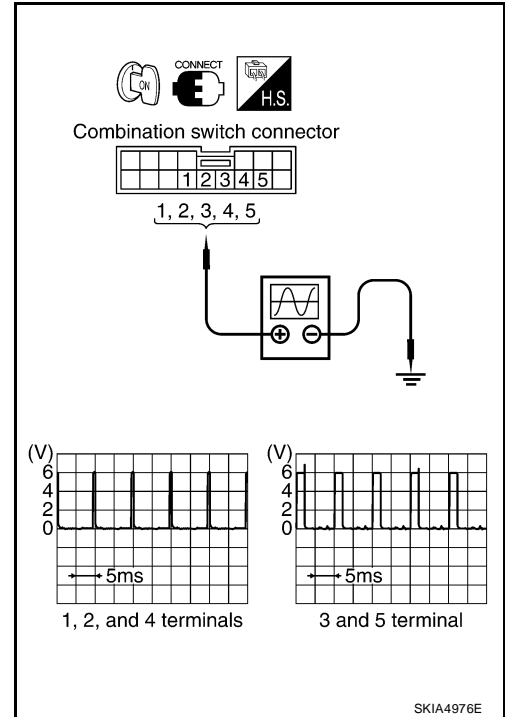

## 5. COMBINATION SWITCH INSPECTION

Referring to table below, perform combination switch inspection.

Procedure									
1	2		3	4		5	6		7
Replace lighting switch.	Confirm check results.	OK	INSPECTION END	Confirm check results.	OK	INSPECTION END	Confirm check results.	OK	INSPECTION END
		NG	Replace wiper switch.		NG	Replace switch base.		NG	Confirm symptom again.

>> Inspection End.

### Removal and Installation

EKS00ABA

For details, refer to [LT-73, "Removal and Installation"](#) .

### Switch Circuit Inspection

EKS00ABB

For details, refer to [LT-77, "Combination Switch Inspection"](#) .

# STOP LAMP

---

## STOP LAMP

PF2:26550

### System Description

EKS00ABC

Power is supplied at all times

- through 10A fuse [No. 20, located in fuse block (J/B)]
- to stop lamp switch terminal 1 and
- to stop lamp relay terminal 1 (with VDC).

When the brake pedal is pressed, the stop lamp switch is closed and power is supplied

- through stop lamp switch terminal 2
- to stop lamp relay terminal 3 (with VDC)
- through stop lamp relay terminal 4 (with VDC)
- to rear combination lamp LH and RH terminal 7, and
- to high-mounted stop lamp terminal 1.

Ground is supplied

- to rear combination lamp LH and RH terminal 5
- through grounds E9, E15 and E24, and
- to high-mounted stop lamp terminal 2
- through grounds B117 and B132.

With power and ground supplied, the stop lamps illuminate.



# STOP LAMP

## Wiring Diagram — STOP/L —

EKS00ABD

### LT-STOP/L-01

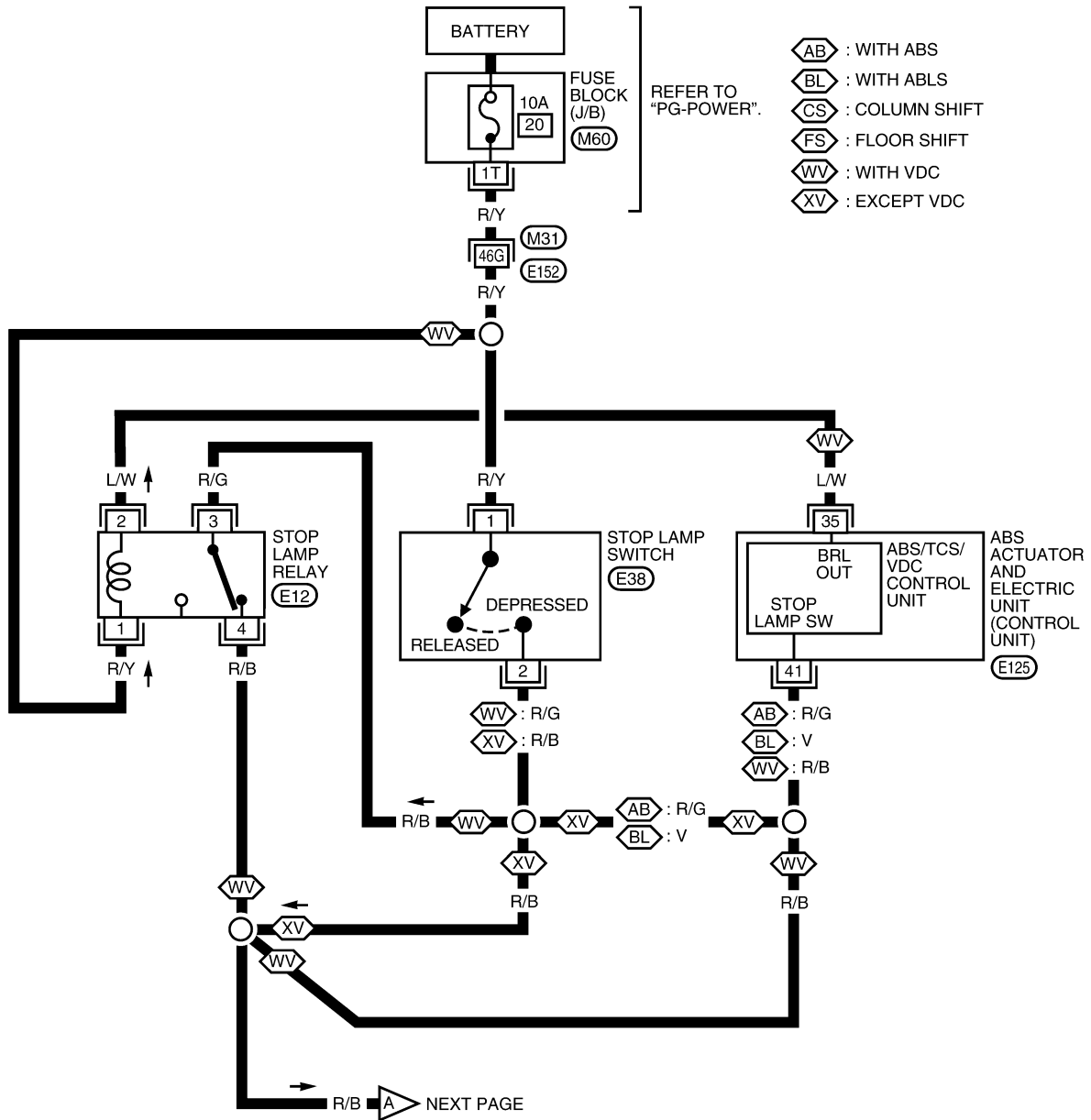

REFER TO THE FOLLOWING.

- M31 - SUPER MULTIPLE JUNCTION (SMJ)
- E125 - ELECTRICAL UNITS

WKWA3768E

# STOP LAMP

LT-STOP/L-02

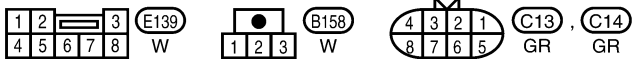
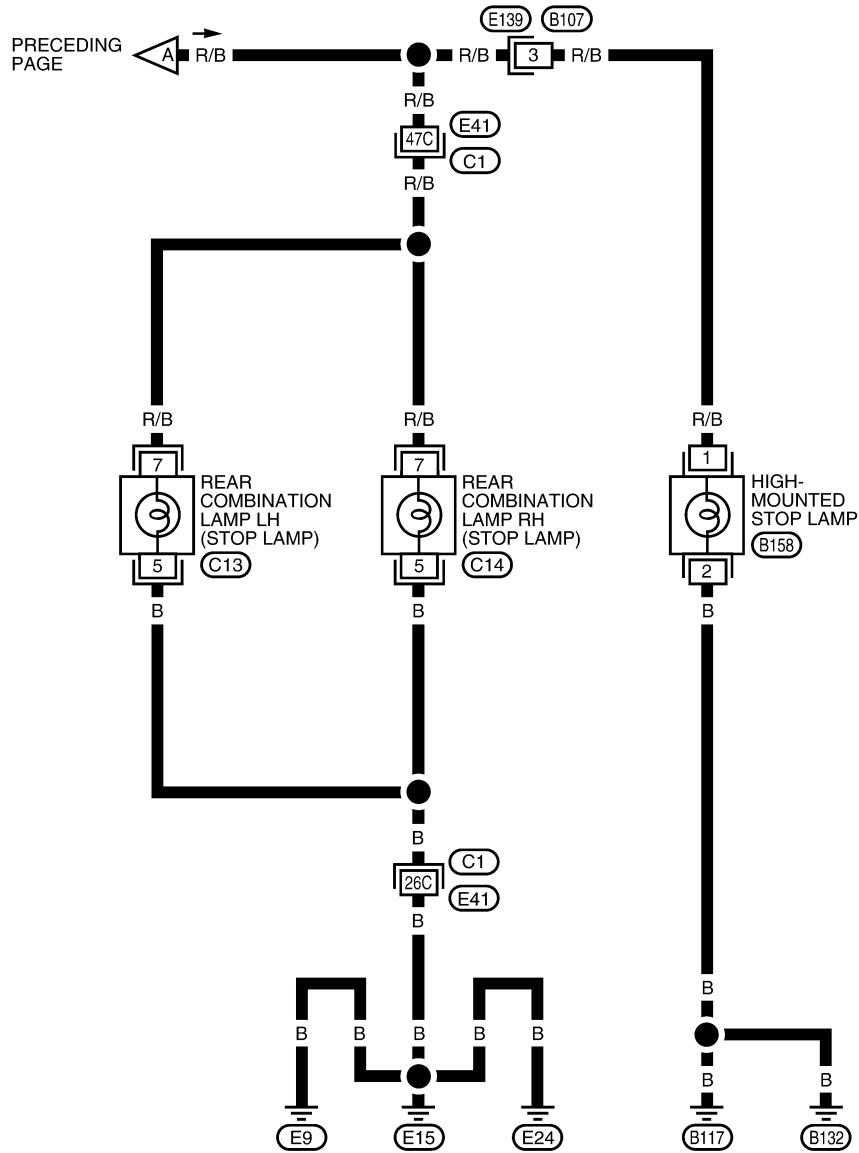

REFER TO THE FOLLOWING.  
 (C1) - SUPER MULTIPLE  
 JUNCTION (SMJ)

WKWA3769E

# STOP LAMP

## Bulb Replacement HIGH-MOUNTED STOP LAMP

EKS00ABE

### Removal

1. Remove the high-mounted stop lamp. Refer to [LT-83, "HIGH-MOUNTED STOP LAMP"](#) .
2. Turn bulb socket counter clockwise to remove it from lamp housing.
3. Pull bulb from socket.

### Installation

Installation is in the reverse order of removal.

## STOP LAMP

Refer to [LT-98, "Bulb Replacement"](#) .

## Removal and Installation HIGH-MOUNTED STOP LAMP

EKS00GKF

### Removal

1. Remove high-mounted stop lamp access covers(3).
2. Disconnect high-mounted stop lamp electrical connector.
3. Remove high-mounted stop lamp nuts(2).
4. Remove high-mounted stop lamp(1).

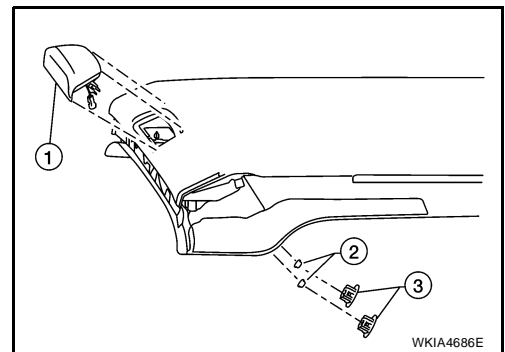

### Installation

Installation is in the reverse order of removal.

## STOP LAMP

Refer to [LT-98, "Removal and Installation"](#) .

A

B

C

D

E

F

G

H

I

J

LT

L

M

# BACK-UP LAMP

PF:26550

## BACK-UP LAMP

### Wiring Diagram — BACK/L —

EKS00ABG

## LT-BACK/L-01

: WITH NAVI

: TRAILER TOW 7 PIN

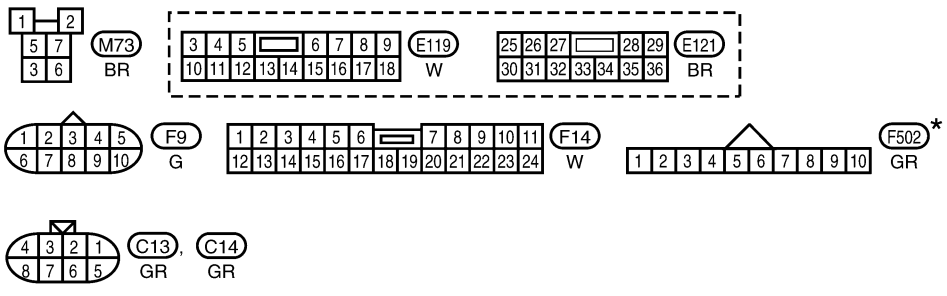
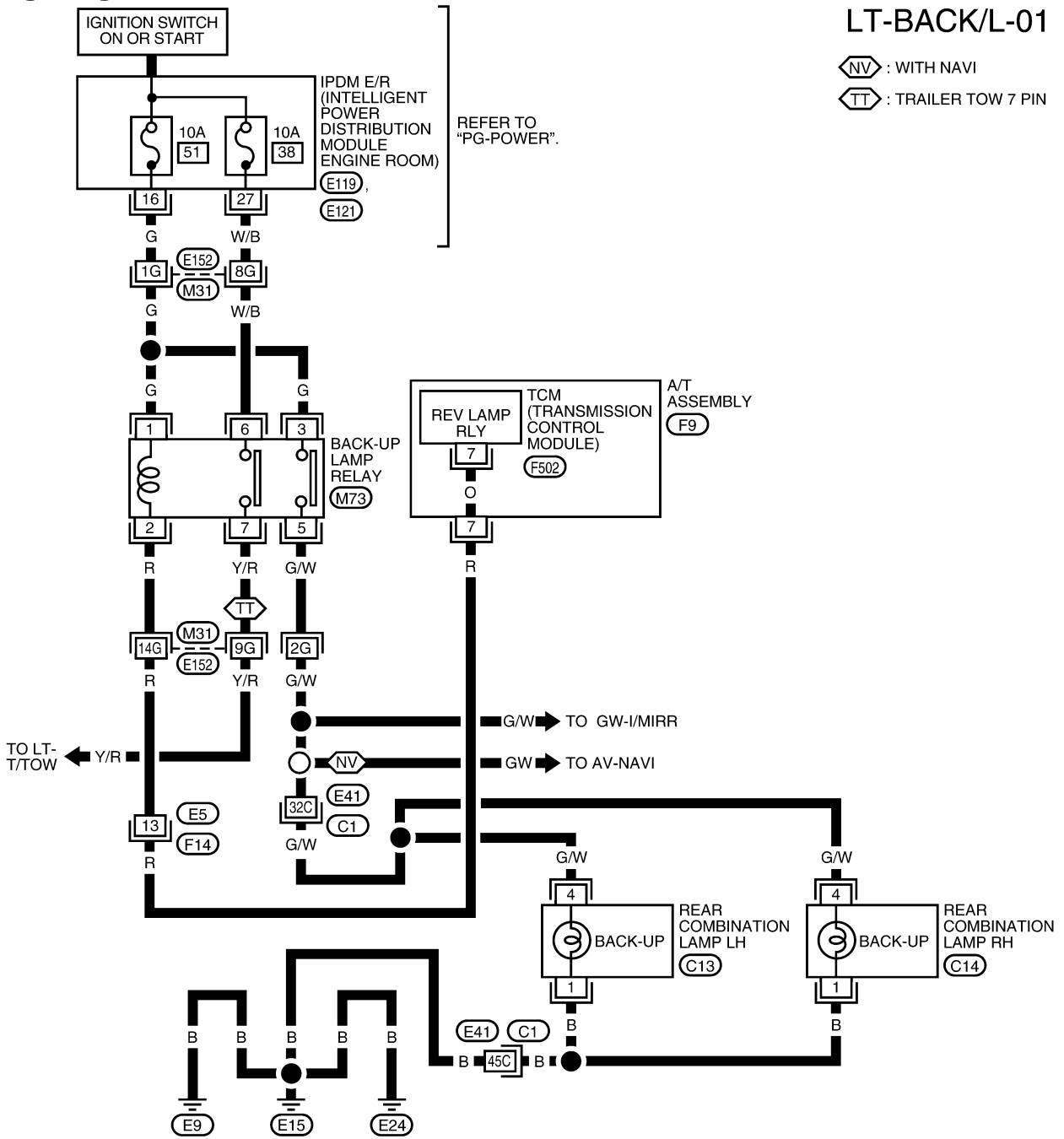

REFER TO THE FOLLOWING.  
 , - SUPER  
 MULTIPLE JUNCTION (SMJ)

\*: THIS CONNECTOR IS NOT SHOWN IN "HARNESS LAYOUT" OF PG SECTION.

WKWA3797E

# BACK-UP LAMP

---

## Bulb Replacement

EKS00ABH

Refer to [LT-98, "Bulb Replacement"](#) .

A

## Removal and Installation

EKS00ABI

Refer to [LT-98, "Removal and Installation"](#) .

B

C

D

E

F

G

H

I

J

LT

L

M

# PARKING, LICENSE PLATE AND TAIL LAMPS

## PARKING, LICENSE PLATE AND TAIL LAMPS

PFP:26550

### Component Parts and Harness Connector Location

EKS00ABJ

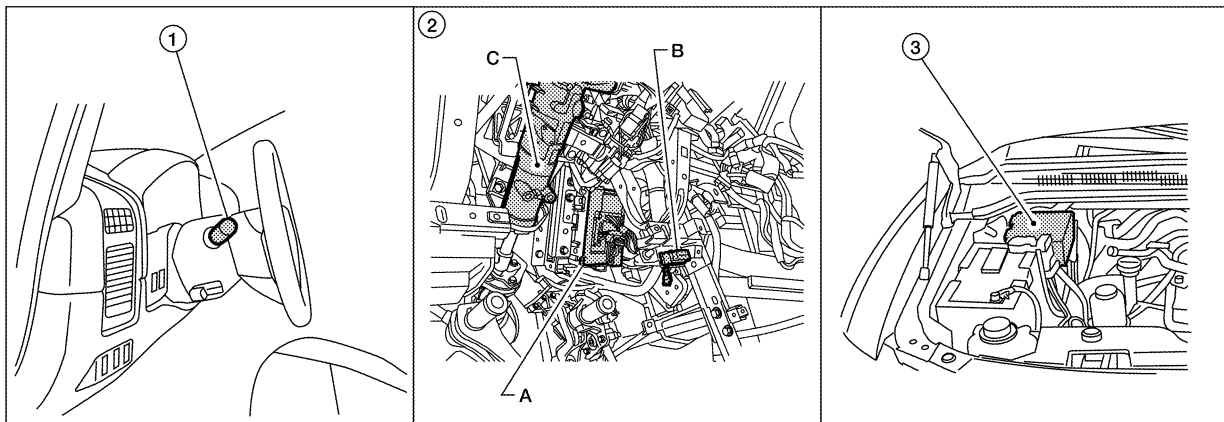

WKIA5595E

1. Combination switch M28
2. A. BCM M18 and M20  
B. Data link connector M22  
C. Steering column (view with instrument lower panel LH removed)
3. IPDM E/R E122 and E124

### System Description

EKS00ABK

Control of the parking, license plate, and tail lamp operation is dependent upon the position of the lighting switch (combination switch). When the lighting switch is placed in the 1ST position, the BCM (body control module) receives input signal requesting the parking, license plate, side marker and tail lamps to illuminate. This input signal is communicated to the IPDM E/R (intelligent power distribution module engine room) across the CAN communication lines. The CPU (central processing unit) of the IPDM E/R controls the tail lamp relay coil. This relay, when energized, directs power to the parking, license plate and tail lamps, which then illuminate.

Power is supplied at all times

- to ignition relay, located in the IPDM E/R,
- to tail lamp relay, located in the IPDM E/R,
- through 20A fuse (No. 53, located in the IPDM E/R)
- to CPU of the IPDM E/R, and
- through 50A fusible link (letter f , located in the fuse and fusible link box)
- to BCM terminal 70.

With the ignition switch in the ON or START position, power is supplied

- to ignition relay, located in the IPDM E/R, and
- through 10A fuse (No. 59, located in the fuse and relay box)
- to BCM terminal 38.

Ground is supplied

- to BCM terminal 67
- through grounds M57, M61 and M79, and
- to IPDM E/R terminals 38 and 59
- through grounds E9, E15 and E24.

### OPERATION BY LIGHTING SWITCH

With the lighting switch in the 1ST or 2ND position (or if the auto light system is activated), the BCM receives input signal requesting the parking, license plate, side marker and tail lamps to illuminate. This input signal is communicated to the IPDM E/R across the CAN communication lines. The CPU of the IPDM E/R controls the tail lamp relay coil, which when energized, directs power

- through 10A fuse (No. 37, located in the IPDM E/R)

# PARKING, LICENSE PLATE AND TAIL LAMPS

- through IPDM E/R terminal 57
- to front combination lamp LH and RH terminal 6,
- to license plate lamps terminal 1, and
- to rear combination lamp LH and RH terminal 6.

Ground is supplied

- to front combination lamp LH and RH terminal 4,
- to rear combination lamp LH and RH terminal 1, and
- to license plate lamps terminal 2
- through grounds E9, E15 and E24.

With power and ground supplied, the parking, license plate and tail lamps illuminate.

## COMBINATION SWITCH READING FUNCTION

Refer to [BCS-3, "COMBINATION SWITCH READING FUNCTION"](#) .

## EXTERIOR LAMP BATTERY SAVER CONTROL

When the combination switch (lighting switch) is in the 1ST (or 2ND) position, and the ignition switch is turned from ON or ACC to OFF, the battery saver control feature is activated.

Under this condition, the parking, license and tail lamps remain illuminated for 5 minutes, then the parking, license plate and tail lamps are turned off.

Exterior lamp battery saver control mode can be changed by the function setting of CONSULT-II.

## CAN Communication System Description

EKS00ABL

Refer to [LAN-2, "CAN Communication System"](#) .

A

B

C

D

E

F

G

H

I

J

LT

L

M

# PARKING, LICENSE PLATE AND TAIL LAMPS

## Schematic

EKS00ABM

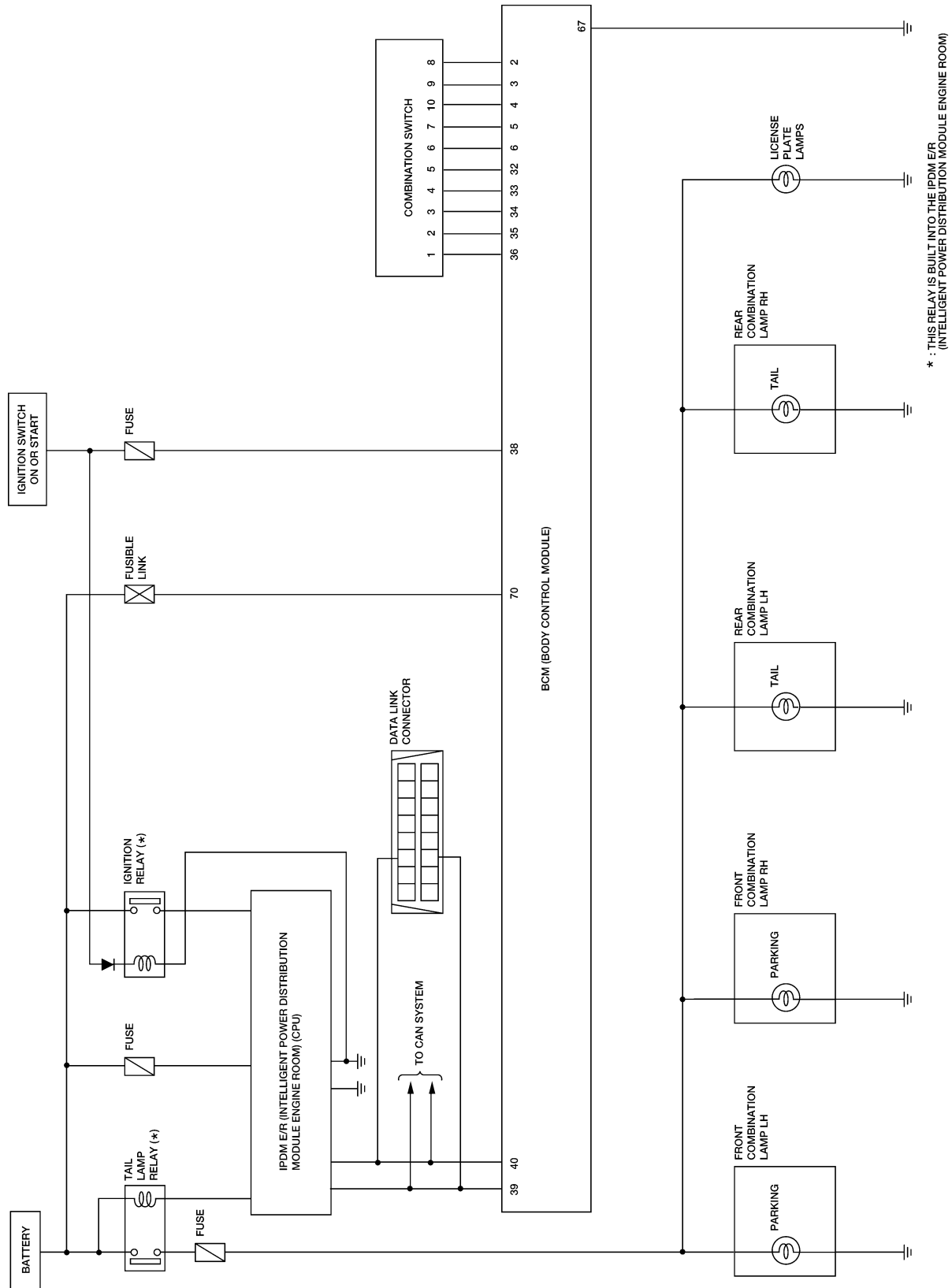

WKWA3770E



# PARKING, LICENSE PLATE AND TAIL LAMPS

## Wiring Diagram — TAIL/L —

EKS00ABN

### LT-TAIL/L-01

— : DATA LINE

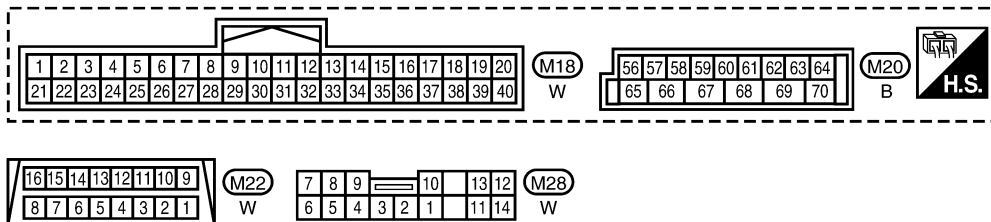
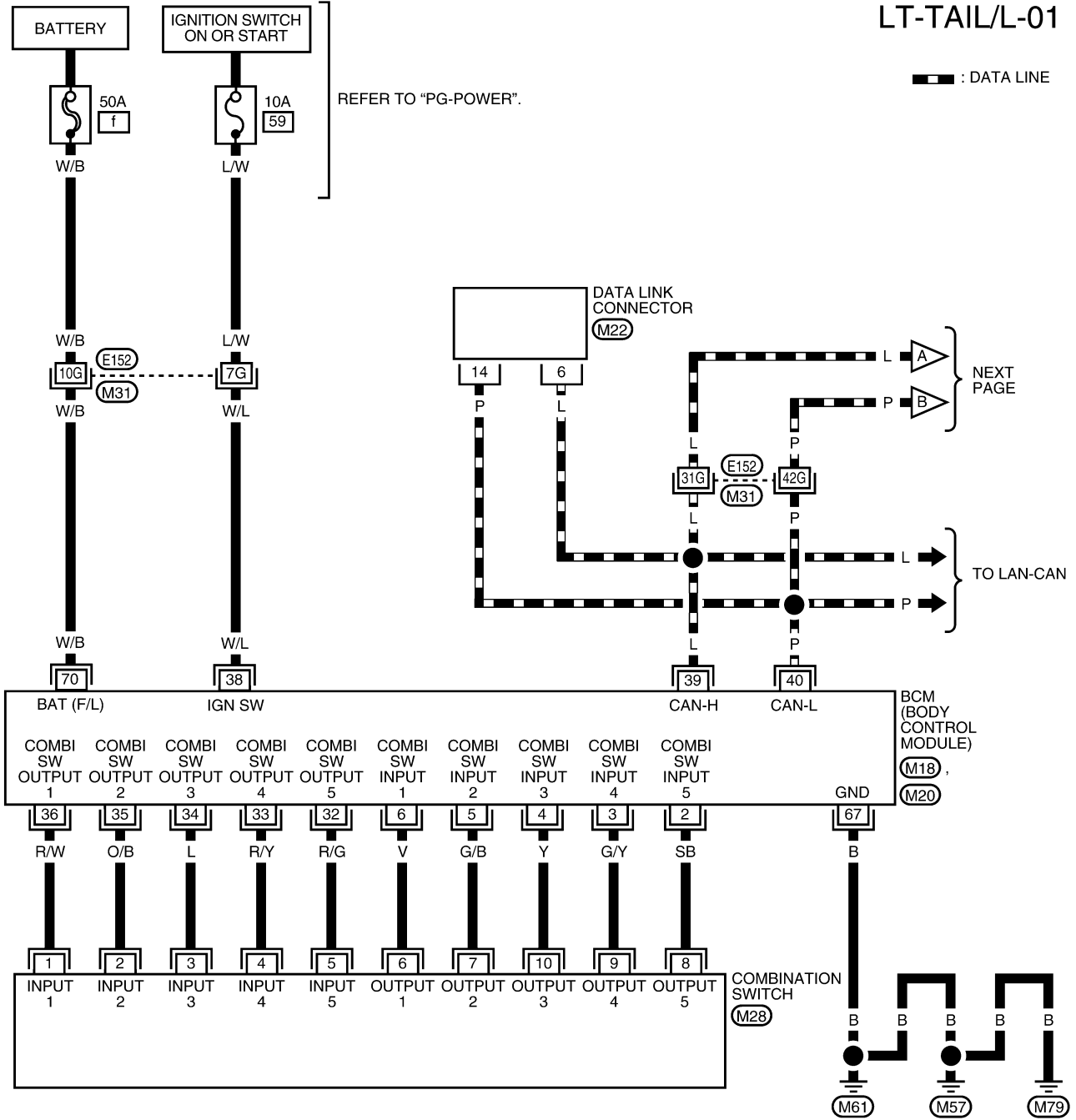

REFER TO THE FOLLOWING.  
 (M31) - SUPER MULTIPLE JUNCTION (SMJ)

WKWA3771E

# PARKING, LICENSE PLATE AND TAIL LAMPS

LT-TAIL/L-02

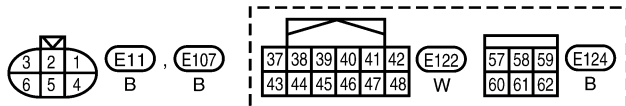
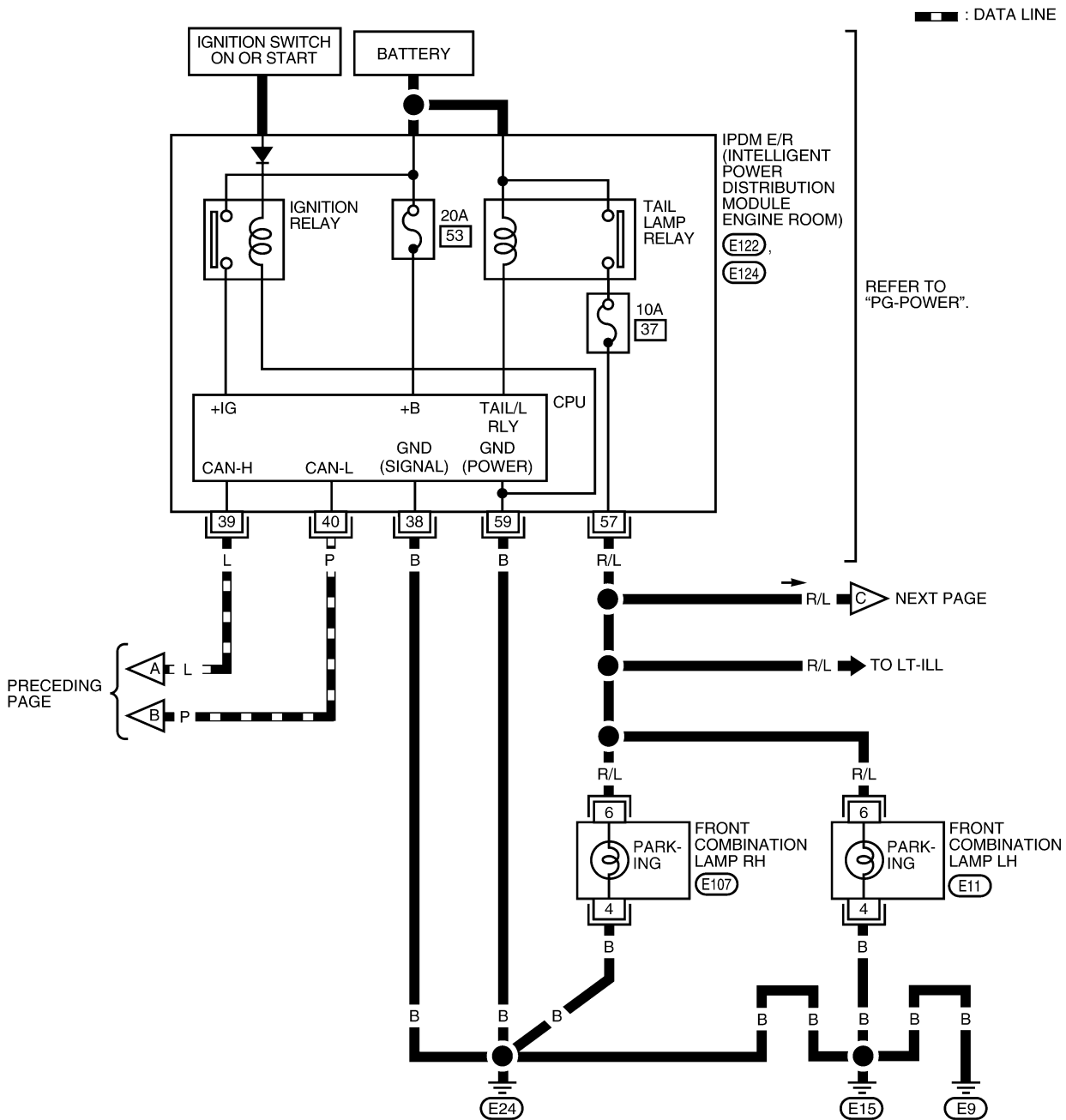

WKWA2415E

# PARKING, LICENSE PLATE AND TAIL LAMPS

LT-TAIL/L-03

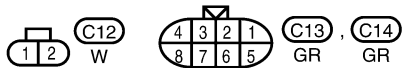
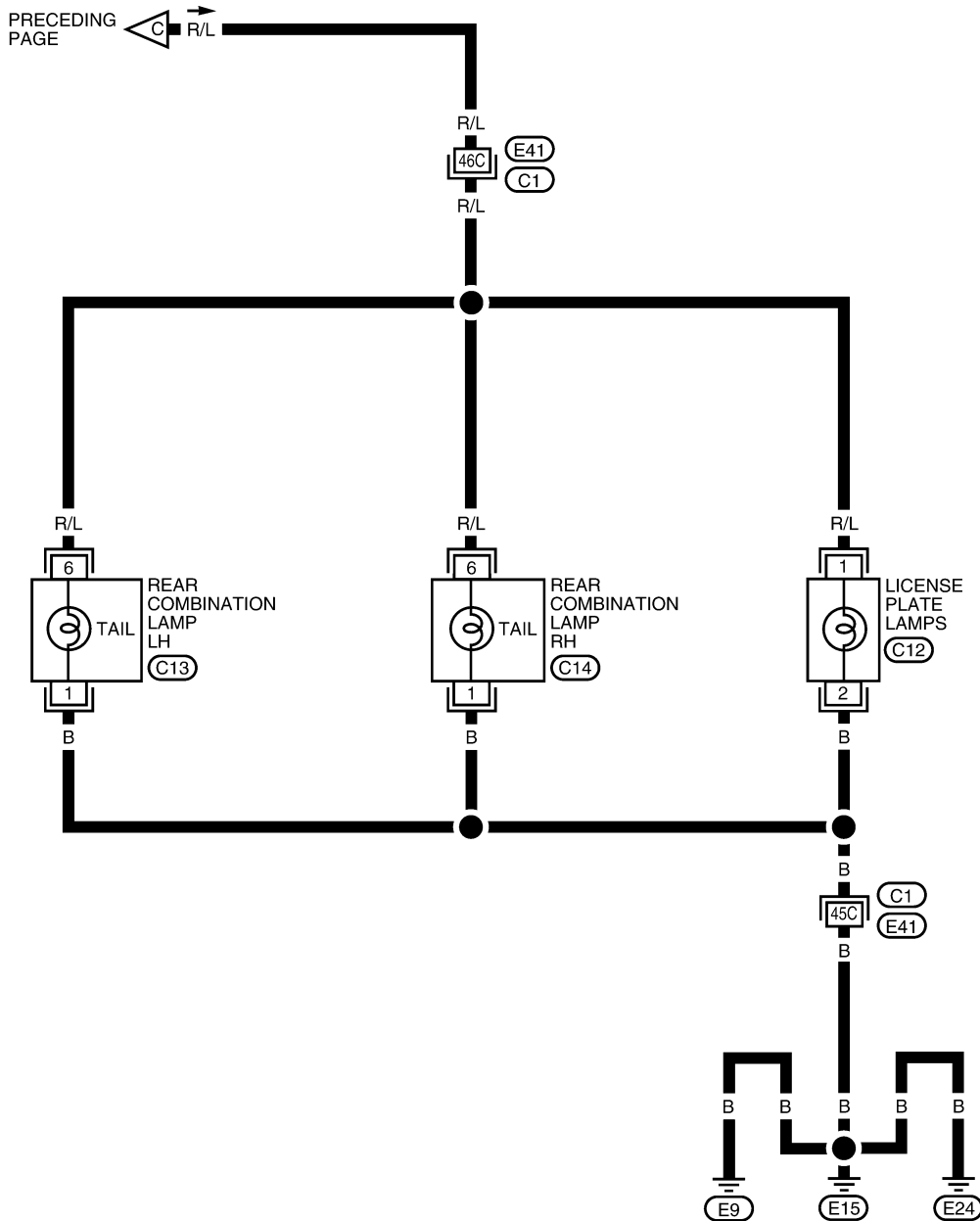

REFER TO THE FOLLOWING.  
 (C1) - SUPER MULTIPLE JUNCTION (SMJ)

WKWA3772E

# PARKING, LICENSE PLATE AND TAIL LAMPS

## Terminals and Reference Values for BCM

EKS00ABO

Refer to [BCS-12, "Terminals and Reference Values for BCM"](#) .

## Terminals and Reference Values for IPDM E/R

EKS00ABP

Refer to [PG-24, "Terminals and Reference Values for IPDM E/R"](#) .

## How to Proceed With Trouble Diagnosis

EKS00ABQ

1. Confirm the symptom or customer complaint.
2. Understand operation description and function description. Refer to [LT-86, "System Description"](#) .
3. Carry out the Preliminary Check. Refer to [LT-92, "Preliminary Check"](#) .
4. Check symptom and repair or replace the component.
5. Do the parking, license and tail lamps operate normally? If YES: GO TO 6. If NO: GO TO 4.
6. Inspection End.

## Preliminary Check

EKS00ABR

### CHECK POWER SUPPLY AND GROUND CIRCUIT TO BCM

Refer to [BCS-16, "BCM Power Supply and Ground Circuit Check"](#) .

### CHECK POWER SUPPLY AND GROUND CIRCUIT TO IPDM E/R

Refer to [PG-28, "IPDM E/R Power/Ground Circuit Inspection"](#) .

## CONSULT-II Function (BCM)

EKS00ABS

Refer to [LT-12, "CONSULT-II Function \(BCM\)"](#) .

## CONSULT-II Function (IPDM E/R)

EKS00ABS

Refer to [LT-13, "CONSULT-II Function \(IPDM E/R\)"](#) .

## Parking, License Plate and/or Tail Lamps Do Not Illuminate

EKS00ABT

### 1. CHECK TAIL LAMP FUSE

Inspect tail lamp 10A fuse (No. 37, located in IPDM E/R).

#### OK or NG

- OK >> GO TO 2.
- NG >> Repair harness.

### 2. CHECK COMBINATION SWITCH INPUT SIGNAL

#### Ⓜ With CONSULT-II

Select "BCM" on CONSULT-II. With "HEAD LAMP" data monitor, make sure "LIGHT SW 1ST" turns ON-OFF linked with operation of lighting switch.

**When lighting switch is in 1ST position : LIGHT SW 1ST ON**

#### ⓧ Without CONSULT-II

Refer to [LT-77, "Combination Switch Inspection"](#) .

#### OK or NG

- OK >> GO TO 3.
- NG >> Check lighting switch. Refer to [LT-77, "Combination Switch Inspection"](#) .

DATA MONITOR	
MONITOR	
LIGHT SW 1ST	ON

SKIA5956E

# PARKING, LICENSE PLATE AND TAIL LAMPS

## 3. ACTIVE TEST

Ⓜ With CONSULT-II

1. Select "IPDM E/R" on CONSULT-II, and select "ACTIVE TEST" on "SELECT DIAG MODE" screen.
2. Select "EXTERNAL LAMPS" on "SELECT TEST ITEM" screen.
3. Touch "TAIL" on "ACTIVE TEST" screen.
4. Make sure parking, license plate and tail lamps operate.

**Parking, license plate and tail lamps should operate**

Ⓧ Without CONSULT-II

1. Start auto active test. Refer to [PG-22, "Auto Active Test"](#) .
2. Make sure parking, license plate and tail lamps operate.

**Parking, license plate and tail lamps should operate**

OK or NG

- OK >> GO TO 4.  
 NG >> GO TO 5.

## 4. CHECK IPDM E/R

1. Select "IPDM E/R" on CONSULT-II, and select "DATA MONITOR" on "SELECT DIAG MODE" screen.
2. Make sure "TAIL&CLR REQ" turns ON when lighting switch is in 1ST position.

**When lighting switch is in 1ST position : TAIL&CLR REQ ON**

OK or NG

- OK >> Replace IPDM E/R. Refer to [PG-30, "Removal and Installation of IPDM E/R"](#) .  
 NG >> Replace BCM. Refer to [BCS-26, "BCM"](#) .

ACTIVE TEST			
EXTERNAL LAMPS		OFF	
		TAIL	
LO		HI	
FOG			
MODE	BACK	LIGHT	COPY

WKIA1438E

DATA MONITOR			
MONITOR			
TAIL&CLR REQ		ON	
		RECORD	
MODE	BACK	LIGHT	COPY

SKIA5958E

A  
B  
C  
D  
E  
F  
G  
H  
I  
J  
LT  
L  
M

# PARKING, LICENSE PLATE AND TAIL LAMPS

## 5. CHECK INPUT SIGNAL

### ④ With CONSULT-II

1. Turn ignition switch OFF.
2. Disconnect front combination lamp, license plate lamp and rear combination lamp connectors.
3. Turn ignition switch ON.
4. Select "IPDM E/R" on CONSULT-II, and select "ACTIVE TEST" on "SELECT DIAG MODE" screen.
5. Select "TAIL LAMP" on "SELECT TEST ITEM" screen.
6. Touch "ON" on "ACTIVE TEST" screen.
7. When tail lamp is operating, check voltage between front combination lamp, license plate lamp, rear combination lamp harness connector and ground.

### ⊗ Without CONSULT-II

1. Turn ignition switch OFF.
2. Start auto active test. Refer to [PG-22, "Auto Active Test"](#) .
3. When tail lamp is operating, check voltage between front combination lamp, license plate lamp, rear combination lamp harness connector and ground.

Front combination lamp (+)		Terminal	(-)	Voltage
Connector				
RH	E107	6	Ground	Battery voltage
LH	E11			

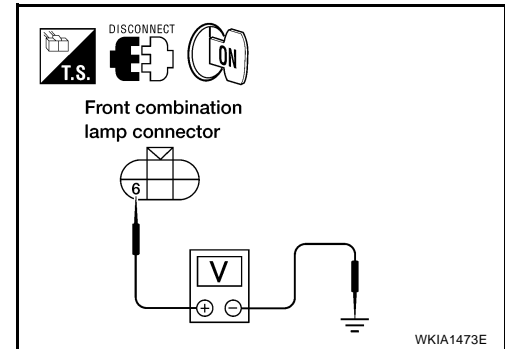

License plate lamps (+)		Terminal	(-)	Voltage
Connector				
C12		1	Ground	Battery voltage

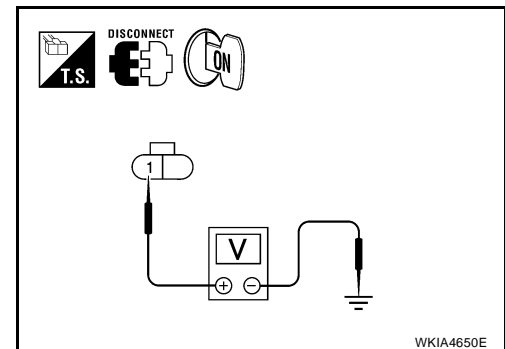

Rear combination lamp (+)		Terminal	(-)	Voltage
Connector				
RH	C14	6	Ground	Battery voltage
LH	C13			

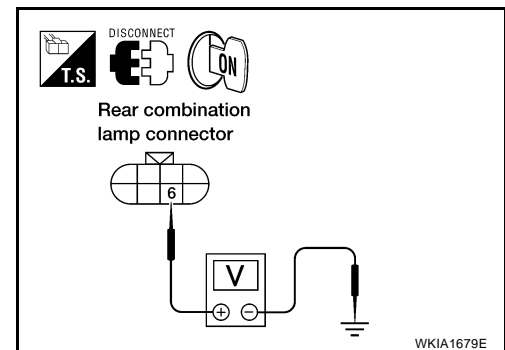

### OK or NG

- OK >> GO TO 7.  
 NG >> GO TO 6.

# PARKING, LICENSE PLATE AND TAIL LAMPS

## 6. CHECK PARKING, LICENSE PLATE AND TAIL LAMP CIRCUIT

1. Turn ignition switch OFF.
2. Disconnect IPDM E/R connector.
3. Check continuity between IPDM E/R harness connector and front combination lamp harness connector.

IPDM E/R		Front combination lamp		Continuity
Connector	Terminal	Connector	Terminal	
E124	57	RH	E107	Yes
		LH	E11	

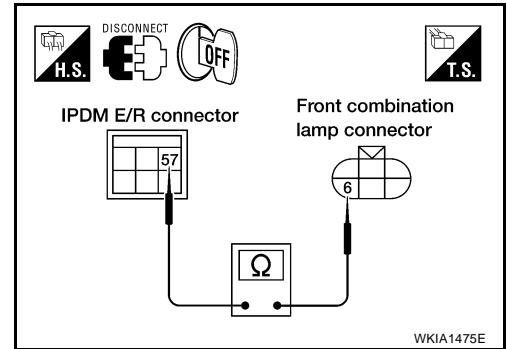

4. Check continuity between IPDM E/R (A) harness connector and license plate lamps (B) harness connector.

IPDM E/R		License plate lamps		Continuity
Connector	Terminal	Connector	Terminal	
E124	57	C12	1	Yes

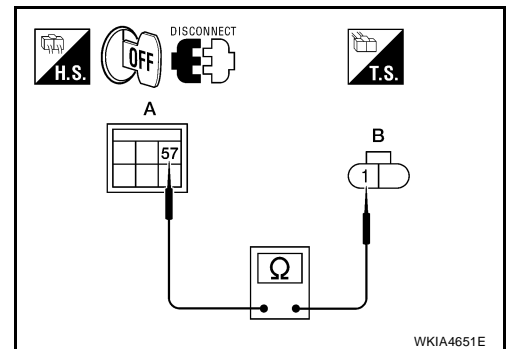

5. Check continuity between IPDM E/R harness connector and rear combination lamp harness connector.

IPDM E/R		Rear combination lamp		Continuity
Connector	Terminal	Connector	Terminal	
E124	57	RH	C14	Yes
		LH	C13	

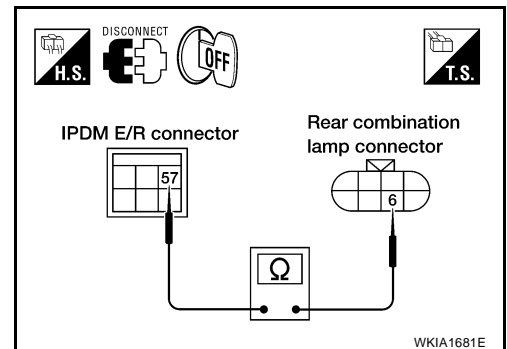

OK or NG

- OK >> Replace IPDM E/R. Refer to [PG-30, "Removal and Installation of IPDM E/R"](#) .
- NG >> Repair harness or connector.

# PARKING, LICENSE PLATE AND TAIL LAMPS

## 7. CHECK GROUND

1. Turn ignition switch OFF.
2. Check continuity between front combination lamp harness connector and ground.

Front combination lamp		Terminal	Ground	Continuity
Connector				
RH	E107	4	Ground	Yes
LH	E11			

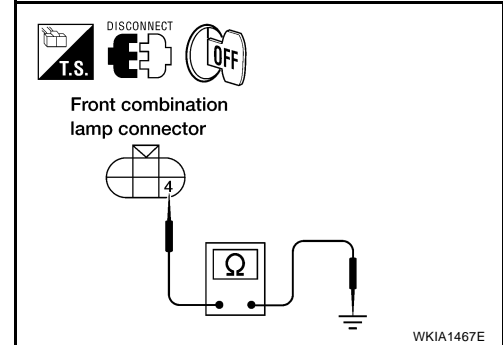

3. Check continuity between license plate lamps harness connector and ground.

License plate lamps		Terminal	Ground	Continuity
Connector				
C12		2	Ground	Yes

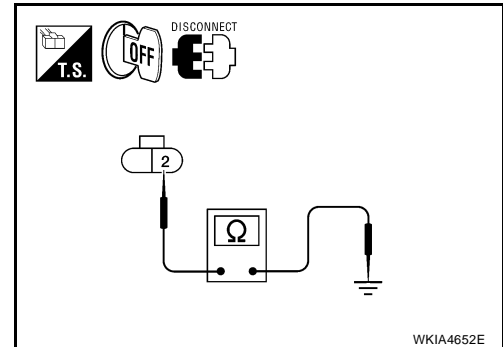

4. Check continuity between rear combination lamp harness connector and ground.

Rear combination lamp		Terminal	Ground	Continuity
Connector				
RH	C14	1	Ground	Yes
LH	C13			

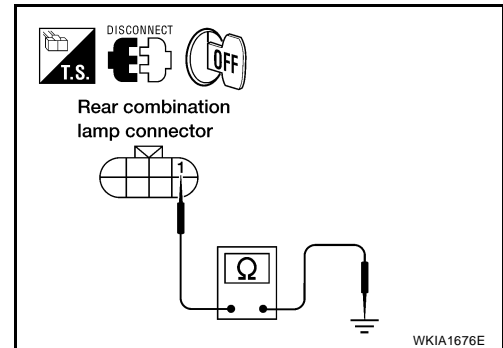

### OK or NG

- OK >> Check bulbs.
- NG >> Repair harness or connector.

## Parking, License Plate and Tail Lamps Do Not Turn OFF (After Approx. 10 Minutes)

EKS00ABU

### 1. CHECK IPDM E/R

1. Turn ignition switch ON. Turn the combination switch (lighting switch) to the OFF position. Turn ignition switch OFF.
2. Verify that the parking, license plate, and tail lamps turn on and off after approximately 10 minutes.

### OK or NG

- OK >> Ignition relay malfunction. Refer to [PG-19, "Function of Detecting Ignition Relay Malfunction"](#).
- NG >> Inspection End.



# PARKING, LICENSE PLATE AND TAIL LAMPS

## Bulb Replacement

EKS00ABV

### PARKING LAMP (FRONT)

A

Refer to [LT-25, "TURN SIGNAL/PARKING LAMP \(FRONT\)"](#) .

### SIDE MARKER LAMP (FRONT)

B

Refer to [LT-25, "SIDE MARKER LAMP \(FRONT\)"](#) .

### TAIL LAMP

Refer to [LT-98, "Bulb Replacement"](#) .

C

## Removal and Installation

EKS00GKG

### PARKING LAMP (FRONT)

D

Refer to [LT-36, "Removal and Installation"](#) .

### SIDE MARKER LAMP (FRONT)

E

Refer to [LT-25, "Removal and Installation"](#) .

### TAIL LAMP

Refer to [LT-98, "Removal and Installation"](#) .

F

G

H

I

J

LT

L

M

# REAR COMBINATION LAMP

## REAR COMBINATION LAMP

PF2:26554

### Bulb Replacement SIDE MARKER LAMP (REAR)

EKS00ABX

#### Removal

1. Remove rear combination lamp mounting bolts.
2. Pull rear combination lamp to remove from the vehicle.
3. Turn side marker lamp (rear) bulb socket counterclockwise and remove bulb.

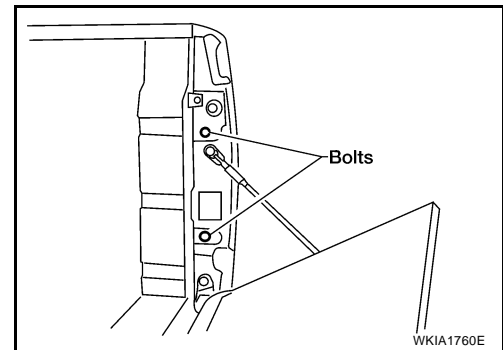

#### Installation

Installation is in the reverse order of removal.

### Removal and Installation REMOVAL

EKS00ABY

1. Remove rear combination lamp mounting bolts.
2. Pull rear combination lamp to remove from the vehicle.
3. Disconnect rear combination lamp connector.

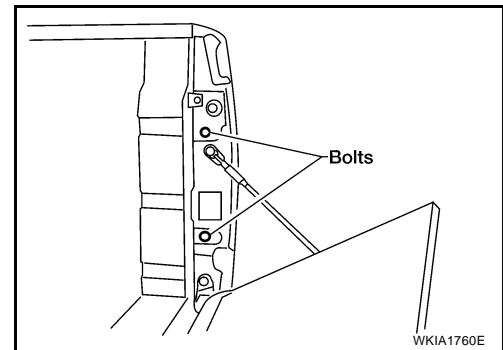

#### INSTALLATION

Installation is in the reverse order of removal.

# TRAILER TOW

PFP:93020

EKS00ABZ

## TRAILER TOW

### Component Parts and Harness Connector Location

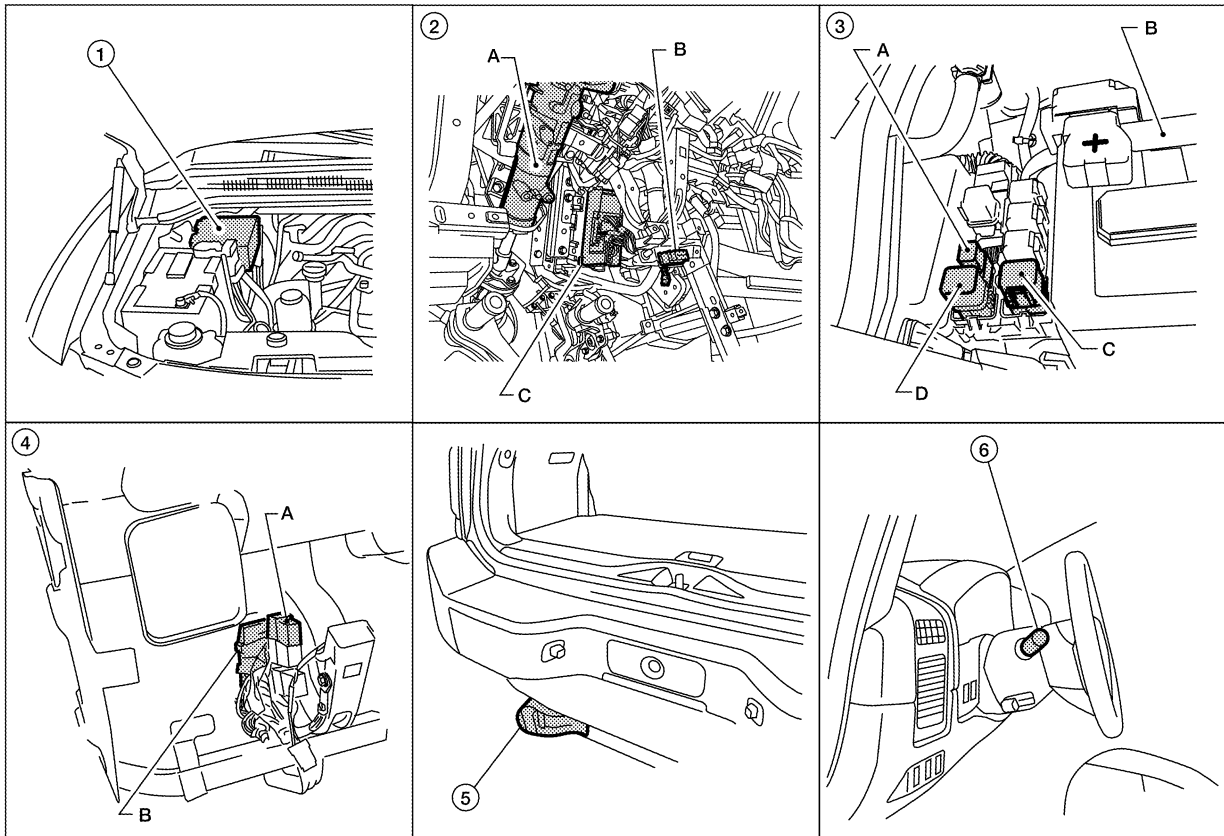

WKIA5597E

- |                                                                                                                               |                                                                                                                                        |                                                                                                                          |
|-------------------------------------------------------------------------------------------------------------------------------|----------------------------------------------------------------------------------------------------------------------------------------|--------------------------------------------------------------------------------------------------------------------------|
| <p>1. IPDM E/R E119, E122 and E124</p>                                                                                        | <p>2. A. Steering column<br/>B. Data link connector M22<br/>C. BCM M18, M19, M20<br/>(view with instrument lower panel LH removed)</p> | <p>3. A. Trailer turn relay LH E158<br/>B. Battery<br/>C. Trailer tow relay 2 E140<br/>D. Trailer turn relay RH E159</p> |
| <p>4. A. Trailer tow relay 1 M51<br/>B. Electric brake (pre-wiring) M76<br/>(view with instrument lower panel LH removed)</p> | <p>5. Trailer connector C2</p>                                                                                                         | <p>6. Combination switch (lighting switch) M28</p>                                                                       |

### System Description

EKS00AC0

Power is supplied at all times

- to ignition relay, located in the IPDM E/R (intelligent power distribution module engine room),
- through 50A fusible link (letter **f** , located in the fuse and fusible link box)
- to BCM (body control module) terminal 70,
- through 15A fuse (No. 60, located in the fuse and relay box)
- to trailer turn relay LH and RH terminal 5,
- through 10A fuse (No. 32, located in the IPDM E/R)
- through IPDM E/R terminal 61
- to trailer tow relay 1 terminal 3,
- through 20A fuse (No. 53, located in the IPDM E/R)
- to CPU (central processing unit) of the IPDM E/R,
- to tail lamp relay, located in the IPDM E/R,
- through 30A fusible link (letter **j** , located in the fuse and fusible link box)
- to trailer tow relay 2 terminals 3 and 6, and
- through 40A fusible link (letter **k** , located in the fuse and fusible link box)

# TRAILER TOW

---

- to electric brake (pre-wiring) terminal 5.
- With the ignition switch in the ON or START position, power is supplied
- to ignition relay, located in the IPDM E/R,
  - through 10A fuse (No. 59, located in the fuse and relay box)
  - to BCM terminal 38, and
  - through 10A fuse (No. 51, located in the IPDM E/R)
  - to trailer tow relay 2 terminal 1.

Ground is supplied

- to BCM terminal 67,
- to electric brake (pre-wiring) terminal 1,
- to trailer tow relay 1 terminal 2
- through grounds M57, M61 and M79, and
- to IPDM E/R terminals 38 and 59,
- to trailer tow relay 2 terminal 2,
- to trailer connector terminal 2,
- to trailer turn relay LH and RH terminal 2
- through grounds E9, E15 and E24.

## TRAILER TAIL LAMP OPERATION

The trailer tail lamps are controlled by the trailer tow relay 1.

With the lighting switch in the parking and tail lamp ON (1ST) position, AUTO position (and the auto light system is activated) or headlamp ON (2ND) position, power is supplied

- through the tail lamp relay, located in the IPDM E/R
- through 10A fuse (No. 36, located in the IPDM E/R)
- to IPDM E/R terminal 49
- to trailer tow relay 1 terminal 1.

When energized, trailer tow relay 1 supplies tail lamp power to trailer connector terminal 6.

## TRAILER TURN SIGNAL AND HAZARD LAMP OPERATION

The trailer turn signal and hazard lamps are controlled by the BCM through trailer turn relays (LH and RH). If either turn signal or the hazard lamps are turned on, the BCM supplies voltage to the trailer turn relays (LH and RH) to make them cycle on and off.

Trailer turn relay LH output is supplied

- through BCM terminal 52
- to trailer turn relay LH terminal 1.

Trailer turn relay RH output is supplied

- through BCM terminal 51
- to trailer turn relay RH terminal 1.

Left turn signal and hazard lamp output is supplied

- through trailer turn relay LH terminal 3
- to trailer connector terminal 1.

Right turn signal and hazard lamp output is supplied

- through trailer turn relay RH terminal 3
- to trailer connector terminal 4.

## TRAILER STOP LAMP OPERATION

The trailer stop lamps are controlled by the electric brake. The electric brake receives stop lamp switch signal when the brake pedal is pressed.

When the brake pedal is pressed, power is supplied

- through electric brake (pre-wiring) terminal 3
- to trailer connector terminal 3.

# TRAILER TOW

---

## TRAILER POWER SUPPLY OPERATION

The trailer power supply is controlled by the trailer tow relay 2.

When the ignition switch is in the ON or START position, power is supplied

- through 10A fuse (No. 51, located in the IPDM E/R)
- through IPDM E/R terminal 16
- to trailer tow relay 2 terminal 1.

When energized, the trailer tow relay 2 supplies power

- through trailer tow relay 2 terminals 5 and 7
- to trailer connector terminal 5.

A

B

C

D

E

F

G

H

I

J

**LT**

L

M

# TRAILER TOW

## Schematic

EKS00AC1

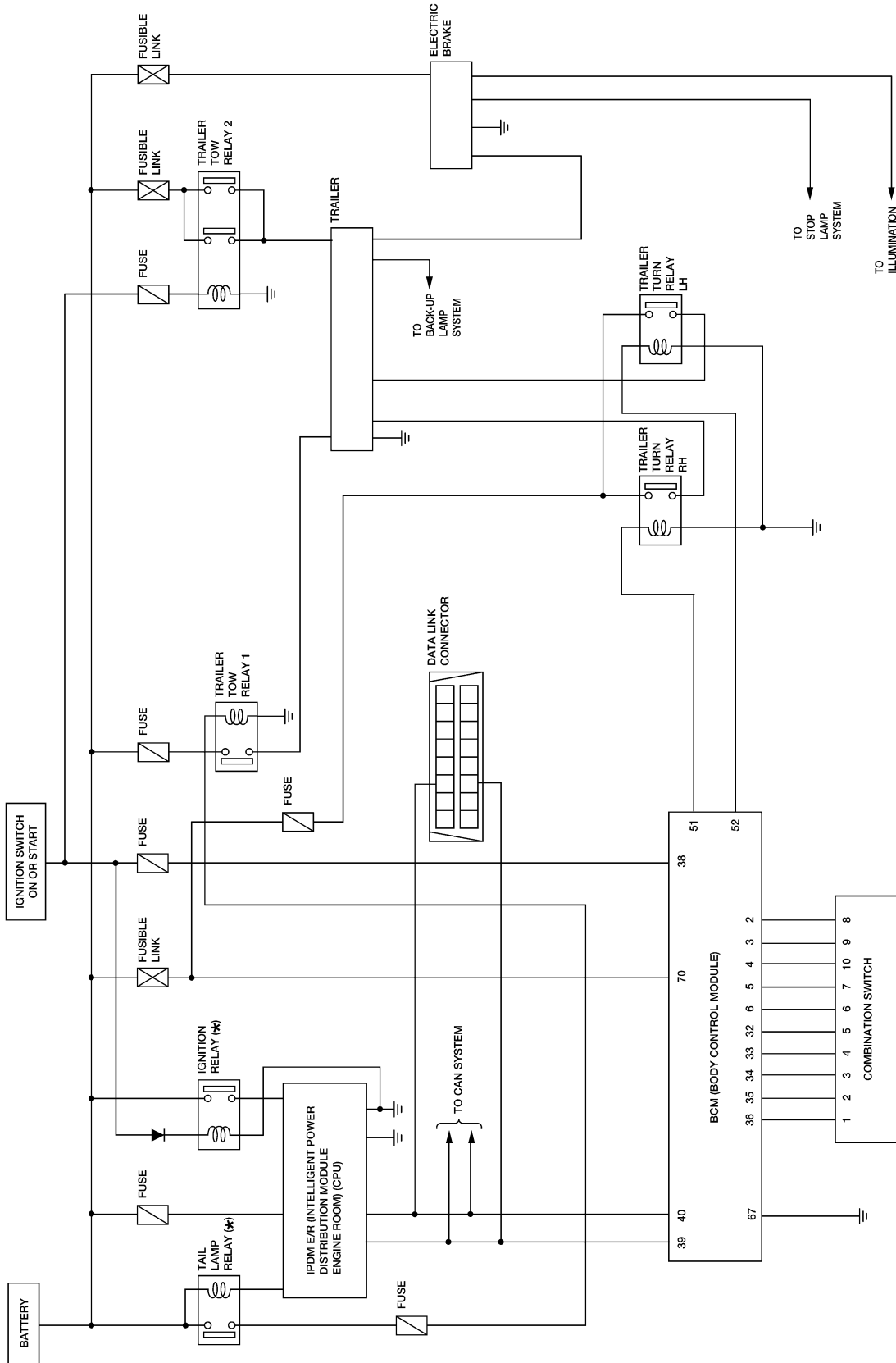

\*: THIS RELAY IS BUILT INTO THE IPDM E/R (INTELLIGENT POWER DISTRIBUTION MODULE ENGINE ROOM)

WKWA3774E

# TRAILER TOW

EKS00AC2

## Wiring Diagram — T/TOW —

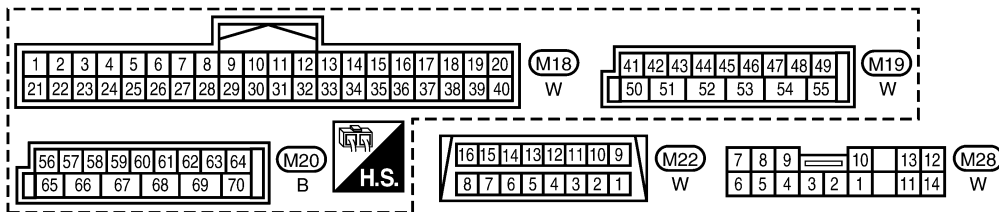
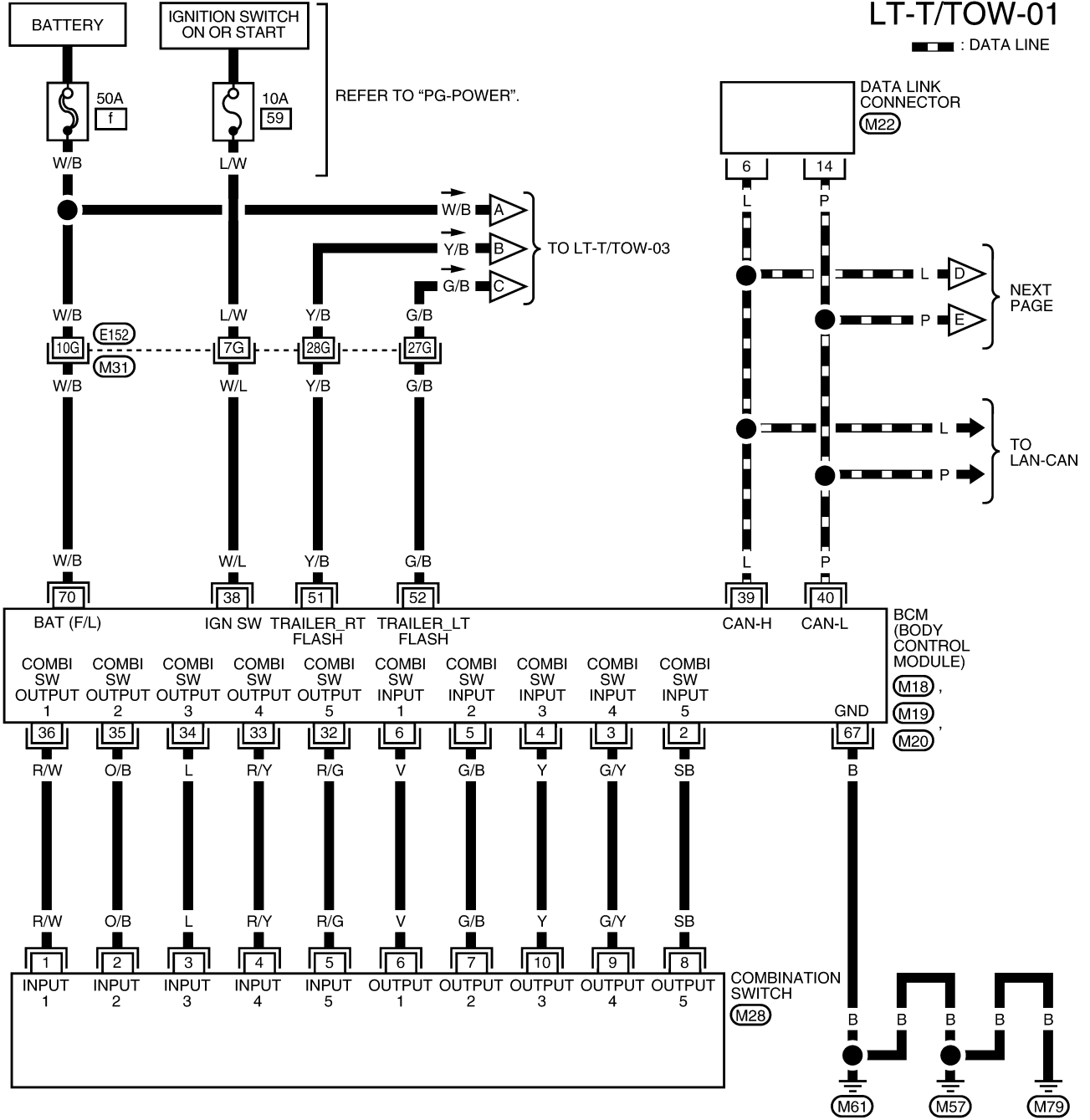

REFER TO THE FOLLOWING.  
 (M31) - SUPER MULTIPLE JUNCTION (SMJ)

WKWA3775E

# TRAILER TOW

LT-T/TOW-02

— : DATA LINE

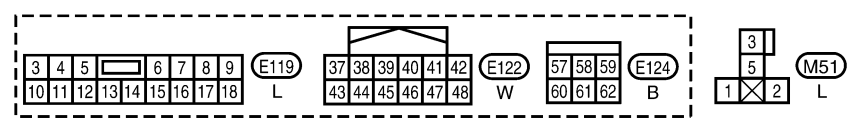
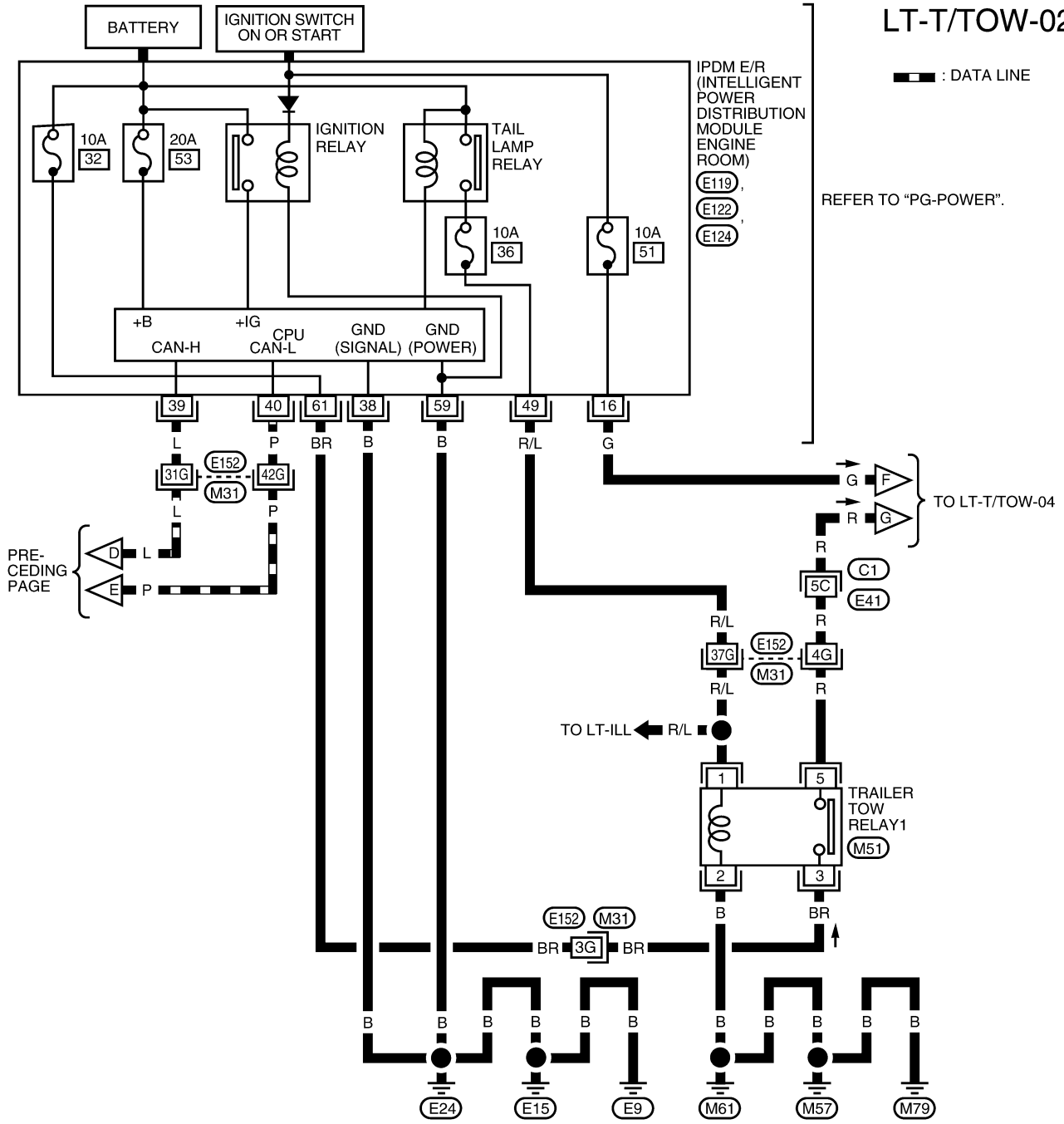

REFER TO THE FOLLOWING.  
 (M31), (C1) - SUPER  
 MULTIPLE JUNCTION (SMJ)

WKWA3776E



# TRAILER TOW

LT-T/TOW-03

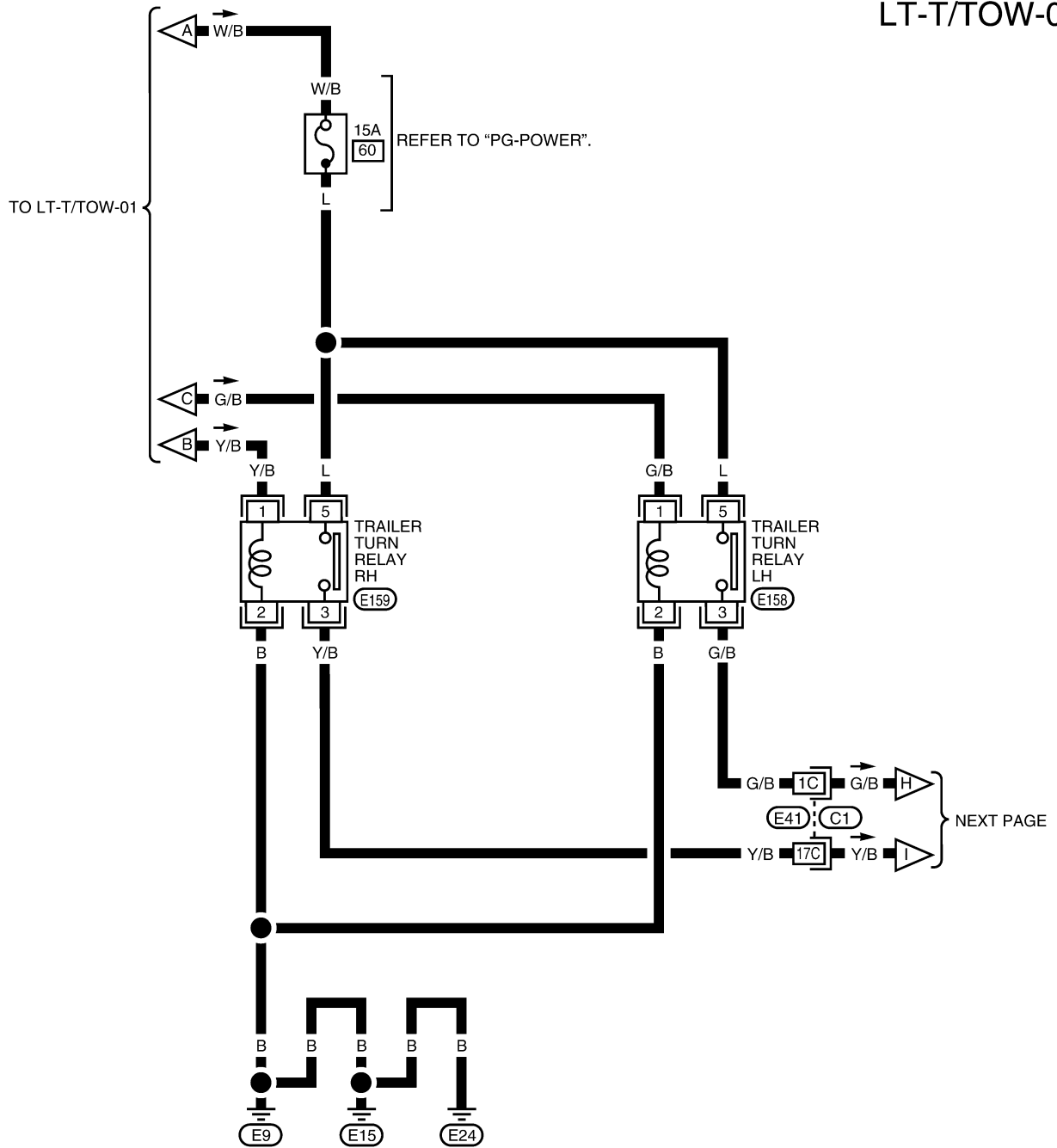

A  
B  
C  
D  
E  
F  
G  
H  
I  
J  
LT  
L  
M

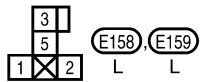

REFER TO THE FOLLOWING.  
 (C1) - SUPER MULTIPLE JUNCTION (SMJ)

WKWA377E

# TRAILER TOW

LT-T/TOW-04

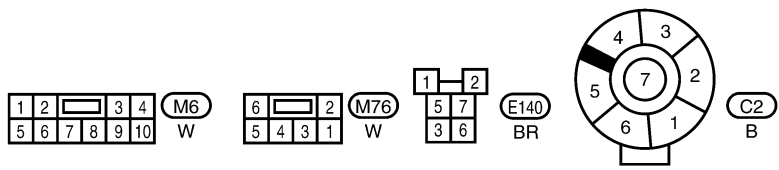
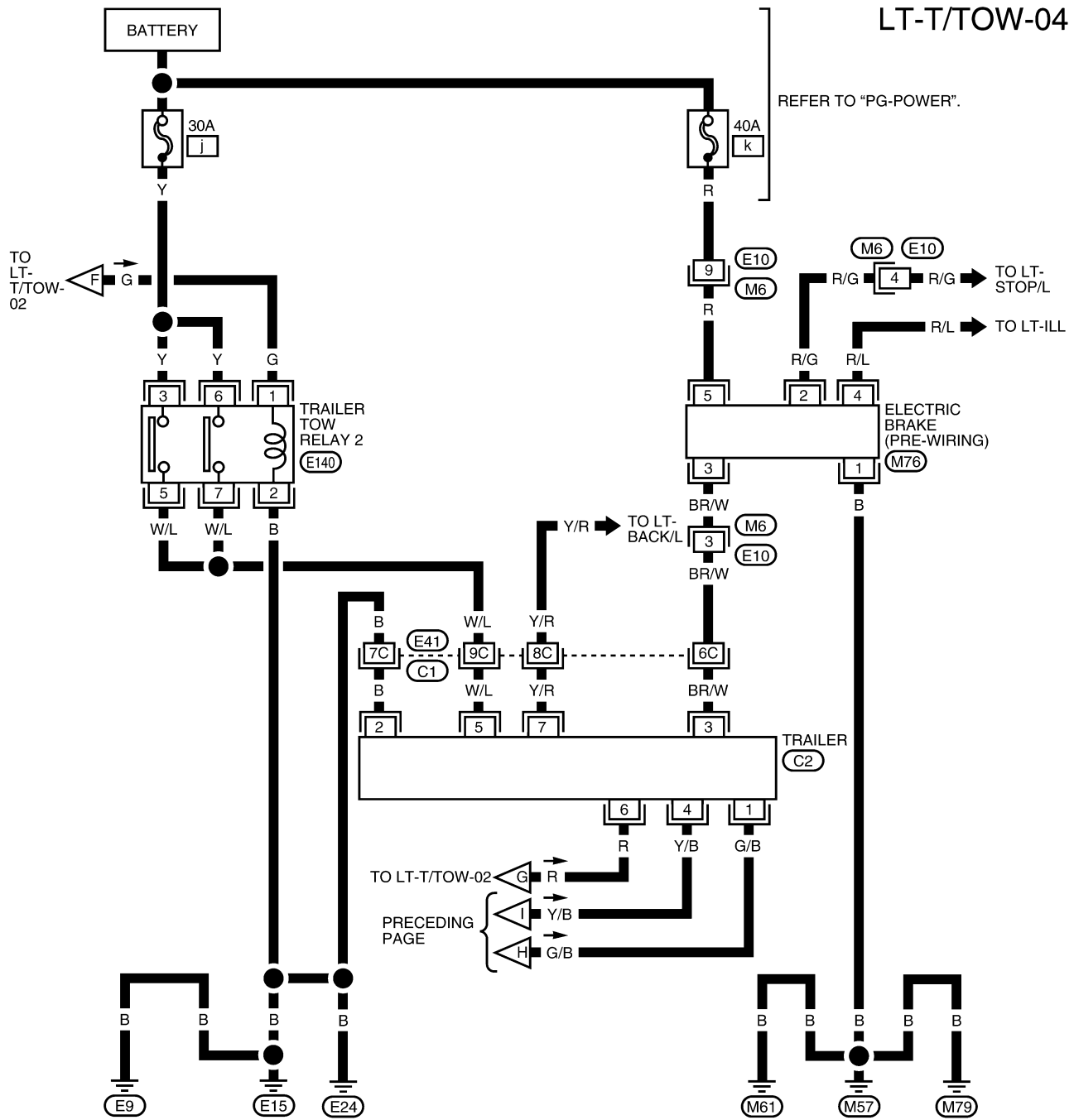

REFER TO THE FOLLOWING.  
 (C1) - SUPER MULTIPLE JUNCTION (SMJ)

WKWA3778E

# INTERIOR ROOM LAMP

PFP:26410

EKS00AC3

## INTERIOR ROOM LAMP

### Component Parts and Harness Connector Location

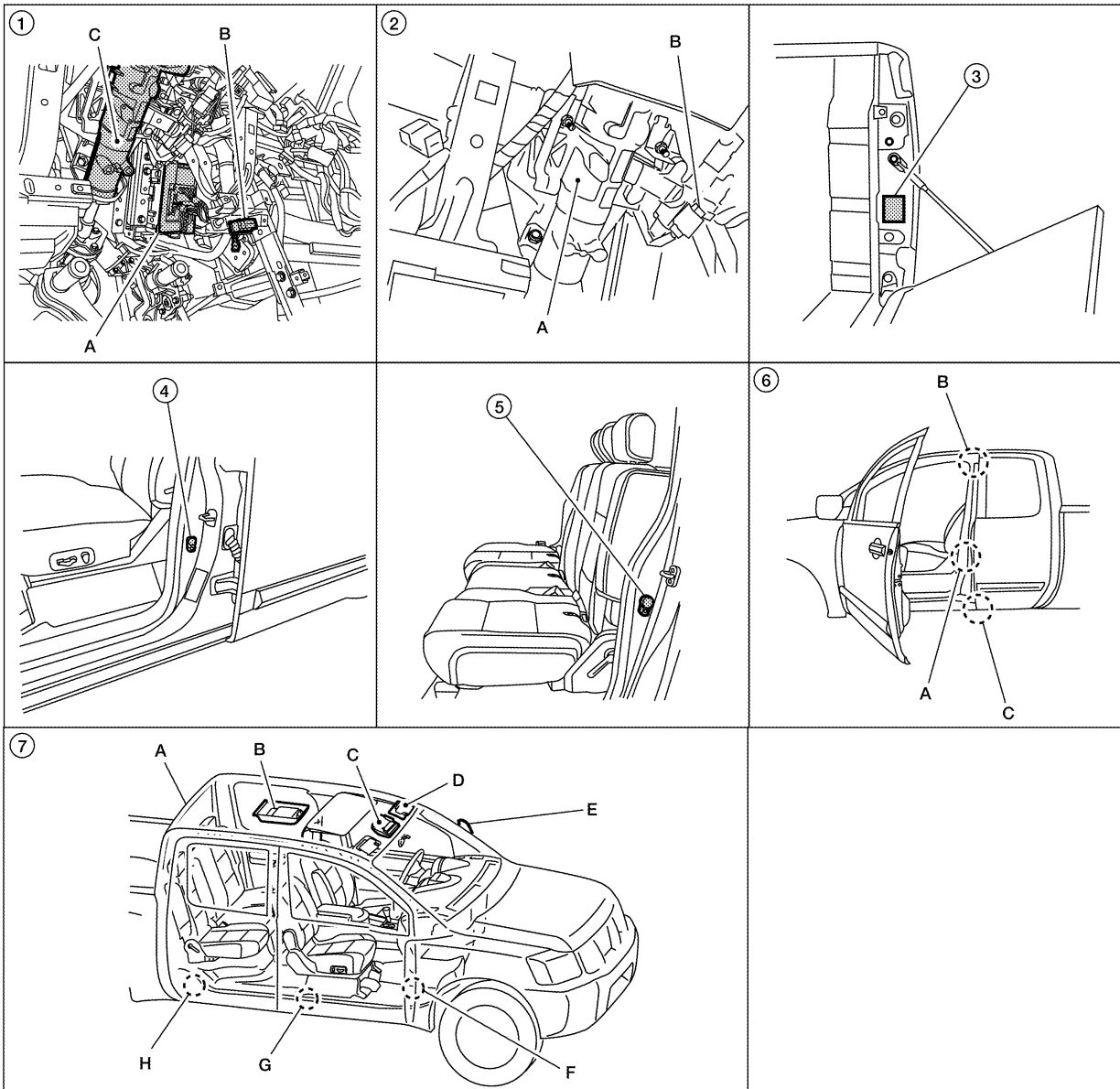

- |                                                                                                                                                                                                                                                                                                           |                                                                                                                                                                                                                                                                                                                      |                                                                                                                                                                                                                                                                                                                     |
|-----------------------------------------------------------------------------------------------------------------------------------------------------------------------------------------------------------------------------------------------------------------------------------------------------------|----------------------------------------------------------------------------------------------------------------------------------------------------------------------------------------------------------------------------------------------------------------------------------------------------------------------|---------------------------------------------------------------------------------------------------------------------------------------------------------------------------------------------------------------------------------------------------------------------------------------------------------------------|
| <p>1. A. BCM M18, M19 and M20<br/>B. Data link connector M22<br/>C. Steering column (view with instrument lower panel LH removed)</p> <p>4. Crew Cab<br/>Front door switch LH B8 and RH B108</p> <p>7. A. Cargo lamp B158<br/>B. Personal lamps 2nd row R203<br/>C. Front room/map lamp assembly R102</p> | <p>2. A. Steering column assembly<br/>B. Key switch and lock solenoid (column shift) M80 or key switch (floor shift) M27</p> <p>5. Crew Cab<br/>Rear door switch LH B18 and RH B118</p> <p>D. Vanity lamp LH R3 and RH R8<br/>E. Door mirror (puddle lamp) LH D4 and RH D107<br/>F. Foot lamp LH M99 and RH M100</p> | <p>3. Tailgate cargo lamp LH C13 and RH C14</p> <p>6. King Cab<br/>A. Front door switch LH B8 and RH B108<br/>B. Rear door switch upper LH B73 and RH B156<br/>C. Rear door switch lower LH B74 and RH B157<br/>G. Front step lamp LH D11 and RH D109<br/>H. Rear step lamp (crew cab only) LH D206 and RH D306</p> |
|-----------------------------------------------------------------------------------------------------------------------------------------------------------------------------------------------------------------------------------------------------------------------------------------------------------|----------------------------------------------------------------------------------------------------------------------------------------------------------------------------------------------------------------------------------------------------------------------------------------------------------------------|---------------------------------------------------------------------------------------------------------------------------------------------------------------------------------------------------------------------------------------------------------------------------------------------------------------------|

WKIA5598E

# INTERIOR ROOM LAMP

EKS00AC4

## System Description

When room lamp and personal lamp switch is in DOOR position, room lamp and personal lamp ON/OFF is controlled by timer according to signals from switches including key switch (with column shift) or key switch and key lock solenoid (with floor shift), front door switch LH side, unlock signal from keyfob, door lock and unlock switch, key cylinder lock and unlock switch, and ignition switch.

When room lamp and personal lamp turns ON, there is a gradual brightening over 1 second. When room lamp and personal lamp turns OFF, there is a gradual dimming over 1 second.

The room lamp and personal lamp timer is controlled by the BCM (body control module).

Room lamp and personal lamp timer control settings can be changed with CONSULT-II.

Step and foot lamp turns ON when front or rear doors are opened (door switch ON). Lamp turns OFF when front and rear doors are closed (all door switches OFF).

## POWER SUPPLY AND GROUND

Power is supplied at all times

- through 10A fuse [No. 19, located in the fuse block (J/B)]
- to key switch terminal 3,
- through 15A fuse [No. 22, located in the fuse block (J/B)]
- to BCM terminal 57,
- through 50A fusible link (letter f , located in the fuse and fusible link box)
- to BCM terminal 70, and
- through 10A fuse [No. 21, located in the fuse block (J/B)]
- to cargo lamp relay terminals 2 and 5.

When the key is inserted in key switch (with column shift) or key switch and key lock solenoid (with floor shift), power is supplied

- through the key switch (with column shift) or key switch and key lock solenoid (with floor shift) terminal 4
- to BCM terminal 37.

With the ignition switch in the ON or START position, power is supplied

- through 10A fuse (No. 59, located in the fuse and relay box)
- to BCM terminal 38.

Ground is supplied

- to BCM terminal 67
- through grounds M57, M61 and M79.

When the front door LH is opened, ground is supplied

- to BCM terminal 47
- through front door switch LH terminal 2
- through case ground of front door switch LH (crew cab) or
- through front door switch LH terminal 3 (king cab)
- through grounds B7 and B19.

When the front door RH is opened, ground is supplied

- to BCM terminal 12
- through front door switch RH terminal 2
- through case ground of front door switch RH (crew cab) or
- through front door switch RH terminal 3 (king cab)
- through grounds B117 and B132 (king cab).

When the rear door LH (crew cab) is opened, ground is supplied

- to BCM terminal 48
- through rear door switch LH terminal 2
- through case ground of rear door switch LH.

When the rear door LH (king cab) is opened, ground is supplied

- to BCM terminal 47
- through rear door switch upper LH and rear door switch lower LH terminal 1

# INTERIOR ROOM LAMP

- through rear door switch upper LH and rear door switch lower LH terminal 2
- through grounds B7 and B19.

When the rear door RH (crew cab) is opened, ground is supplied

- to BCM terminal 13
- through rear door switch RH terminal 2
- through case ground of rear door switch RH.

When the rear door RH (king cab) is opened, ground is supplied

- to BCM terminal 12
- through rear door switch upper RH and rear door switch lower RH terminal 1
- through rear door switch upper RH and rear door switch lower RH terminal 2
- through grounds B117 and B132.

When the front door LH or RH is unlocked by the door lock and unlock switch, BCM receives serial data

- to BCM terminal 22
- through main power window and door lock/unlock switch terminal 14 (crew cab) or 12 (king cab) and power window and door lock/unlock switch RH terminal 16
- through main power window and door lock/unlock switch terminal 17 (crew cab) or 15 (king cab)
- through grounds M57, M61 and M79.

When the front door LH is unlocked by the key, the BCM receives serial data

- to BCM terminal 22
- through main power window and door lock/unlock switch terminal 14 (crew cab) or 12 (king cab)
- through main power window and door lock/unlock switch terminal 6 (crew cab) or 7 (king cab)
- through front door lock assembly LH (key cylinder switch) terminal 6
- to front door lock assembly LH (key cylinder switch) terminal 5
- through grounds M57, M61 and M79.

When a signal, or combination of signals is received by the BCM, ground is supplied

- to door mirror LH and RH terminal 13 (with puddle lamps)
- to front room/map lamp assembly terminal 1 (with front roof console) and
- to personal lamps 2nd row terminal 1 (with rear roof console)
- through front room/map lamp assembly terminal 2 (with front roof console)
- through BCM terminal 63.

With power and ground supplied, the lamps illuminate.

When the BCM receives cargo lamp switch input, ground is supplied to cargo lamp relay terminal 1, which energizes the cargo lamp relay. When this relay is energized, power is supplied

- through cargo lamp relay terminal 3
- to high-mount stop lamp (cargo lamp) terminal 3, and
- to rear combination lamp (tailgate cargo lamp) LH and RH terminal 3 (with tailgate cargo lamps).

Ground is supplied

- to high-mount stop lamp (cargo lamp) terminal 2
- through grounds B117 and B132, and
- to rear combination lamp LH and RH (tailgate cargo lamp) terminal 1 (with tailgate cargo lamps)
- through grounds E9, E15 and E24.

With power and ground supplied, the lamps illuminate.

## SWITCH OPERATION

When any door switch is ON (door is opened), ground is supplied

- to front and rear (crew cab) step lamps LH and RH
- to foot lamp LH and RH (with foot lamps) terminal –
- through BCM terminal 62.

And power is supplied

- through BCM terminal 56

A  
B  
C  
D  
E  
F  
G  
H  
I  
J  
LT  
L  
M

## INTERIOR ROOM LAMP

---

- to front and rear (crew cab) step lamps LH and RH terminal +
- to door mirror LH and RH terminal 12 (with puddle lamps)
- to front room/map lamp assembly terminal 6 (with front roof console)
- to vanity lamp LH and RH terminal 1 (with vanity lamps)
- to personal lamp 2nd row terminal 3 (with rear roof console)
- to room lamp terminal 2
- to foot lamp LH and RH terminal + (with foot lamps).

When front room/map lamp assembly switch is ON, ground is supplied

- to front room/map lamp assembly terminal 5 (with front roof console)
- through grounds M57, M61 and M79.

When vanity lamp (LH or RH) is ON, ground is supplied

- to vanity lamp (LH or RH) terminal 2 (with vanity lamps)
- through grounds M57, M61 and M79.

When cargo lamp switch is ON, ground is supplied

- to BCM terminal 31
- through cargo lamp switch terminal 1
- through cargo lamp switch terminal 3
- through grounds M57, M61 and M79.

### ROOM LAMP TIMER OPERATION

When lamp switch is in DOOR position, and when all conditions below are met, BCM performs timer control (maximum 30 seconds) for interior room lamp and map lamp ON/OFF.

Power is supplied

- through 10A fuse [No. 19, located in the fuse block (J/B)]
- to key switch (with column shift) or key switch and key lock solenoid (with floor shift) terminal 3.

Key is removed from key switch (with column shift) or key switch and key lock solenoid (with floor shift) (key switch OFF), power will not be supplied to BCM terminal 37.

Serial data is supplied

- to BCM terminal 22
- through main power window and door lock/unlock switch terminal 14 (crew cab) or 12 (king cab).

At the time that front door LH is opened, BCM detects that front door LH is unlocked. It determines that interior room lamp and map lamp timer operation conditions are met, and turns the interior room lamps ON for 30 seconds.

Key is in key switch (with column shift) or key switch and key lock solenoid (with floor shift) (key switch ON), power is supplied

- through key switch (with column shift) or key switch and key lock solenoid (with floor shift) terminal 4
- to BCM terminal 37.

When key is removed from key switch (with column shift) or key switch and key lock solenoid (with floor shift) (key switch OFF), power supply to BCM terminal 37 is terminated. BCM detects that key has been removed, determines that interior room lamp and map lamp timer conditions are met, and turns the interior room lamps ON for 30 seconds.

When front door LH opens → closes, and the key is not inserted in the key switch (with column shift) or key switch and key lock solenoid (with floor shift) (key switch OFF), BCM terminal 47 changes between 0V (door open) → 12V (door closed). The BCM determines that conditions for interior room lamp operation are met and turns the interior room lamp ON for 30 seconds.

Timer control is canceled under the following conditions.

- Front door LH is locked [when locked by keyfob, main power window and door lock/unlock switch or front door lock assembly LH (key cylinder switch)]
- Front door LH is opened (front door switch LH turns ON)
- Ignition switch ON.

### INTERIOR LAMP BATTERY SAVER CONTROL

If interior lamp is left ON, it will not be turned off even when door is closed.

BCM turns off interior lamp automatically to save battery 30 minutes after ignition switch is turned off.

# INTERIOR ROOM LAMP

---

BCM controls interior lamps listed below:

- Room lamp
- Vanity lamps
- Front room/map lamp assembly
- Personal lamp 2nd row
- Step lamps
- Puddle lamps
- Foot lamps

After lamps turn OFF by the battery saver system, the lamps illuminate again when

- signal received from keyfob, or main power window and door lock/unlock switch or front door lock assembly LH (key cylinder switch) is locked or unlocked
- door is opened or closed
- key is removed from key switch (with column shift) or key switch and key lock solenoid (with floor shift) or inserted in key switch (with column shift) or key switch and key lock solenoid (with floor shift).

Interior lamp battery saver control period can be changed by the function setting of CONSULT-II.

A

B

C

D

E

F

G

H

I

J

**LT**

L

M

# INTERIOR ROOM LAMP

## Schematic

EKS00AC5

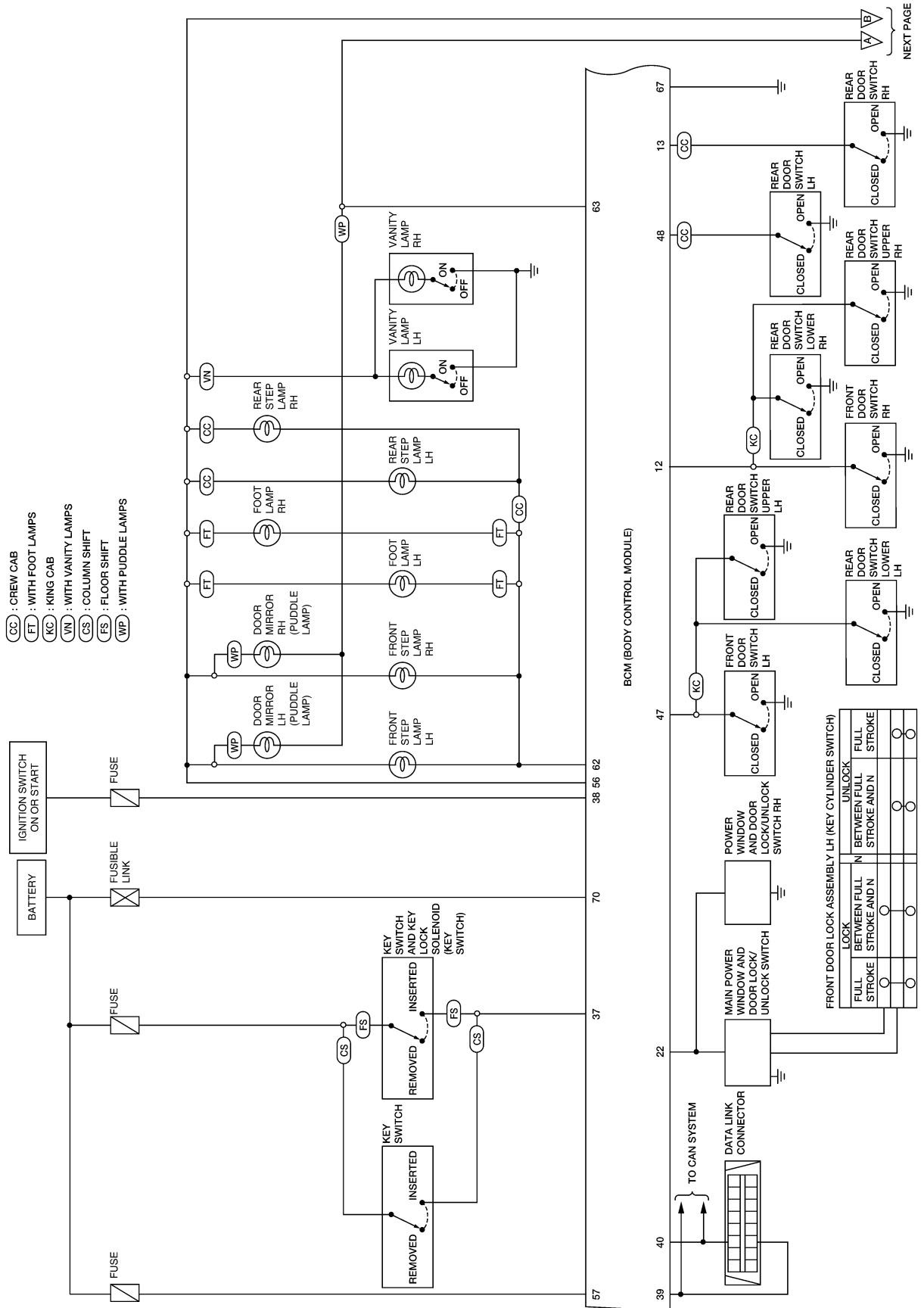



# INTERIOR ROOM LAMP

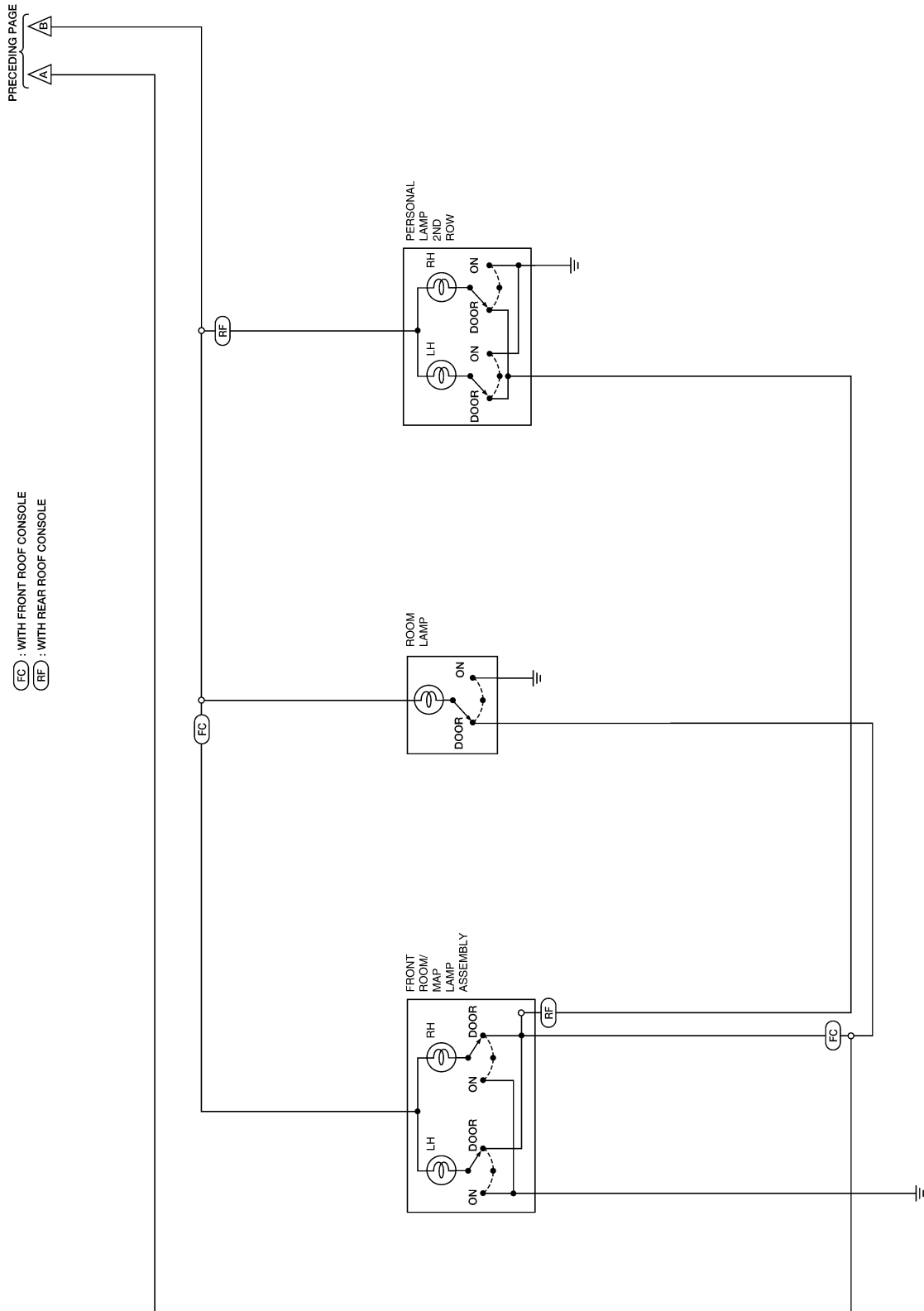

A  
B  
C  
D  
E  
F  
G  
H  
I  
J  
LT  
L  
M

WKWA3780E

# INTERIOR ROOM LAMP

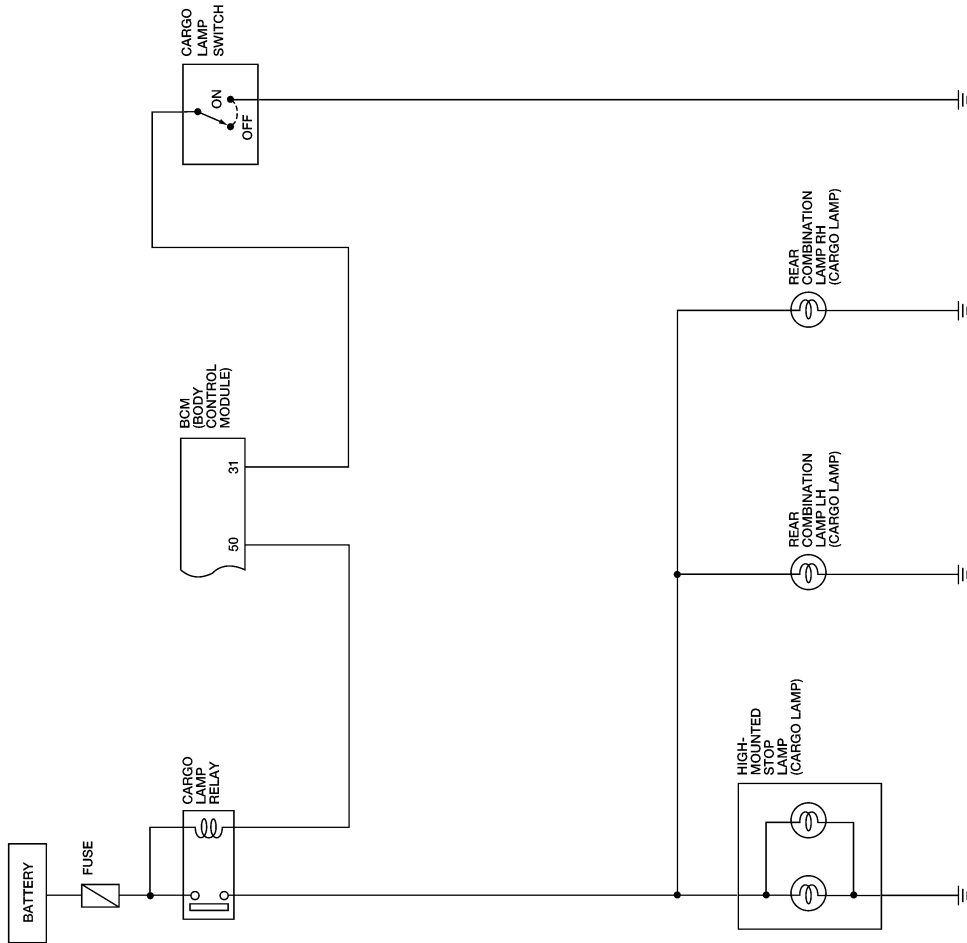

LKWA0285E

# INTERIOR ROOM LAMP

## Wiring Diagram — INT/L —

EKS00AC6

LT-INT/L-01

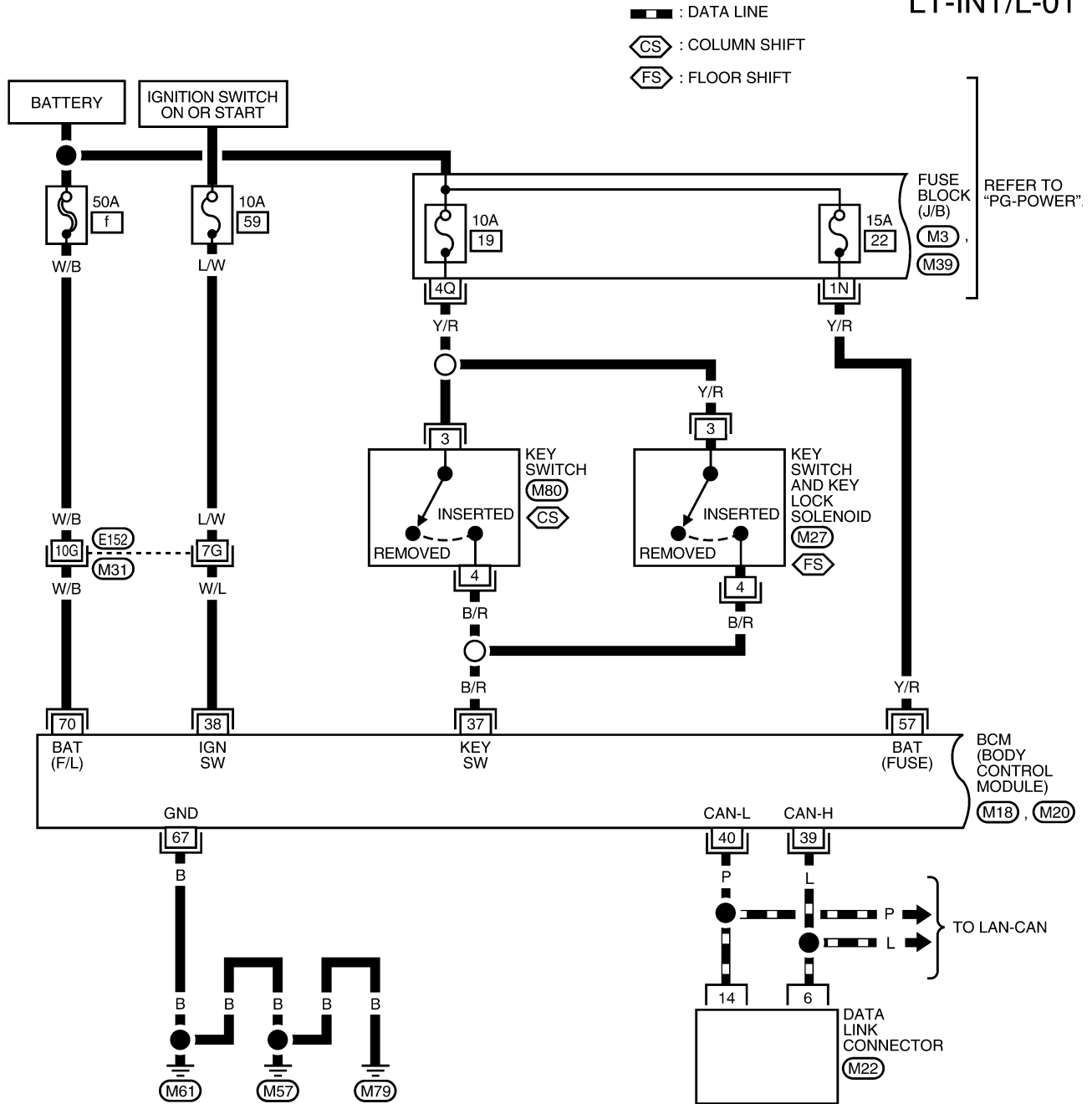

A  
B  
C  
D  
E  
F  
G  
H  
I  
J  
LT  
L  
M

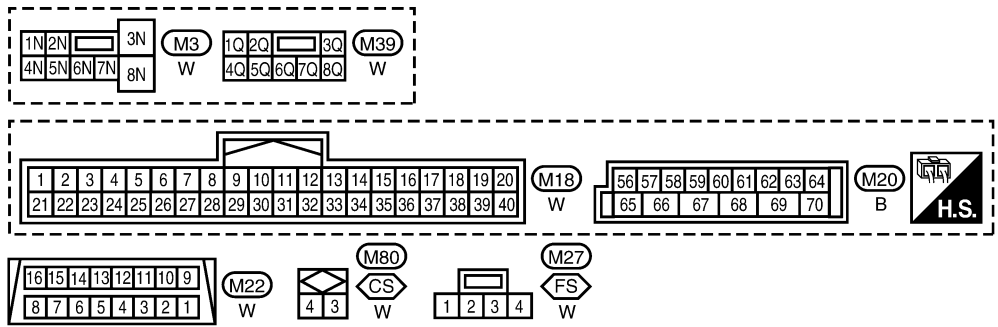

REFER TO THE FOLLOWING.  
M31 - SUPER MULTIPLE JUNCTION (SMJ)

WKWA2448E

# INTERIOR ROOM LAMP

LT-INT/L-02

CC : CREW CAB  
KC : KING CAB

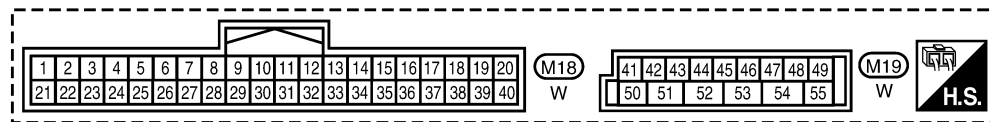
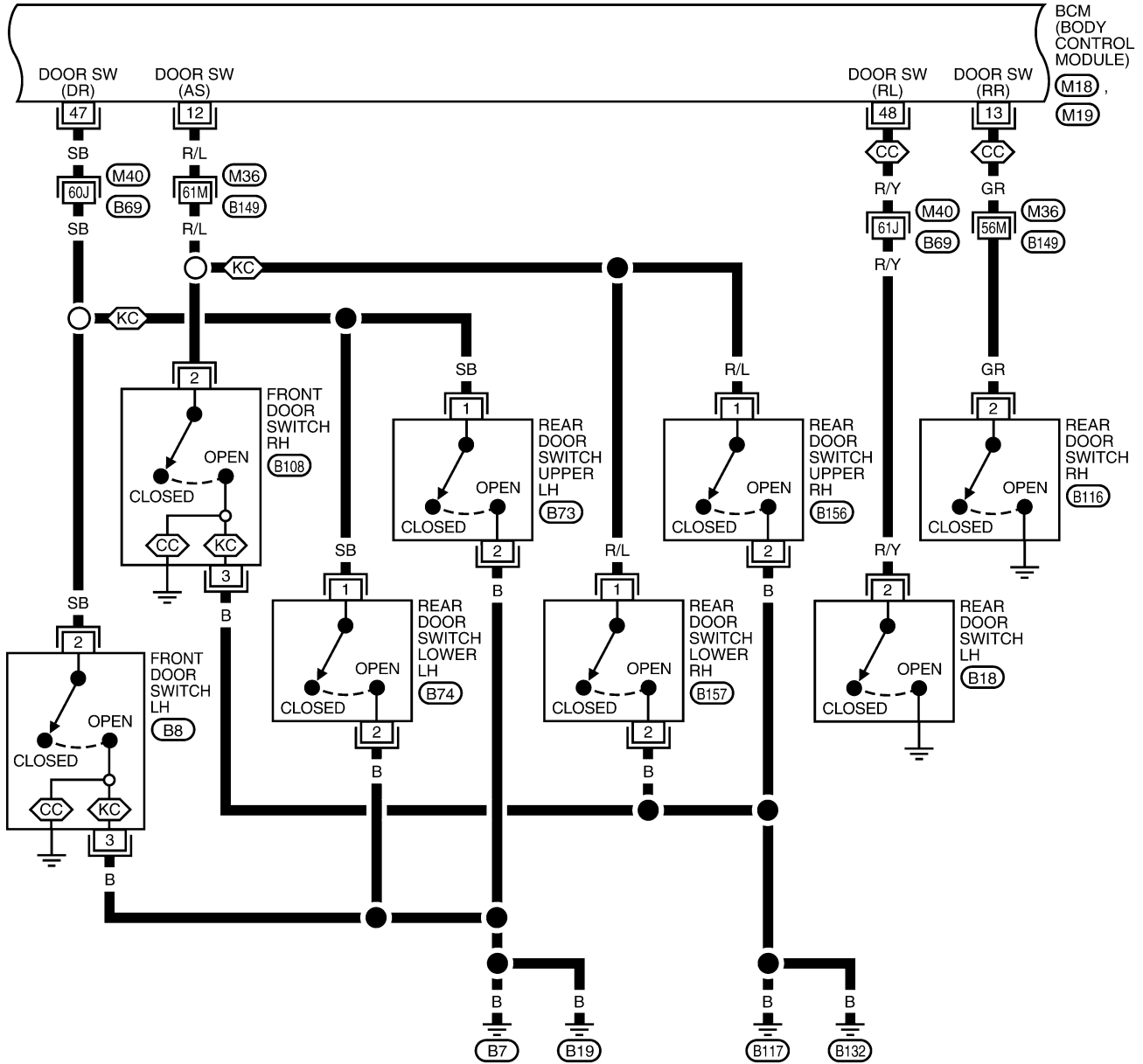

REFER TO THE FOLLOWING.  
M36, M40 - SUPER  
 MULTIPLE JUNCTION (SMJ)

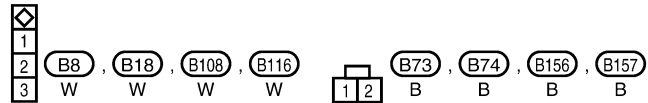

LKWA0286E

# INTERIOR ROOM LAMP

LT-INT/L-03

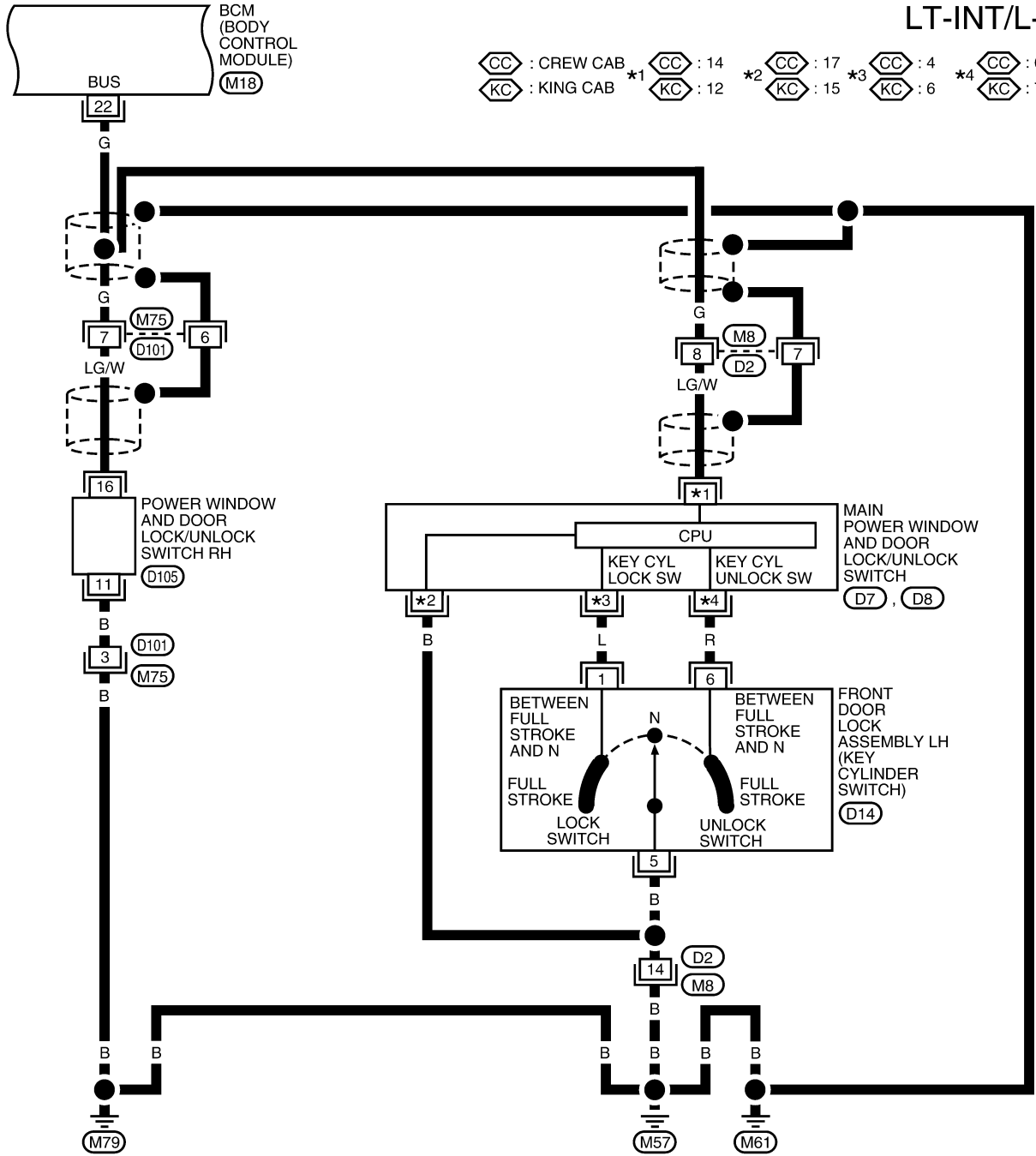

A

B

C

D

E

F

G

H

I

J

LT

L

M

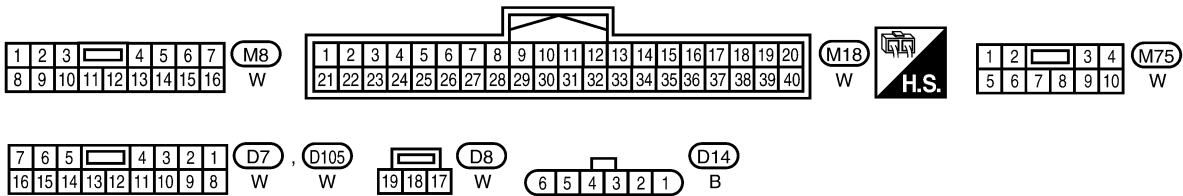

WKWA5155E

# INTERIOR ROOM LAMP

LT-INT/L-04

FC : WITH FRONT ROOF CONSOLE  
 WP : WITH PUDDLE LAMPS

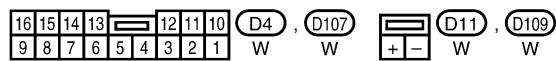
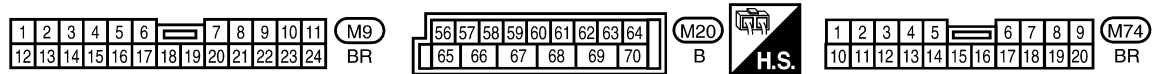
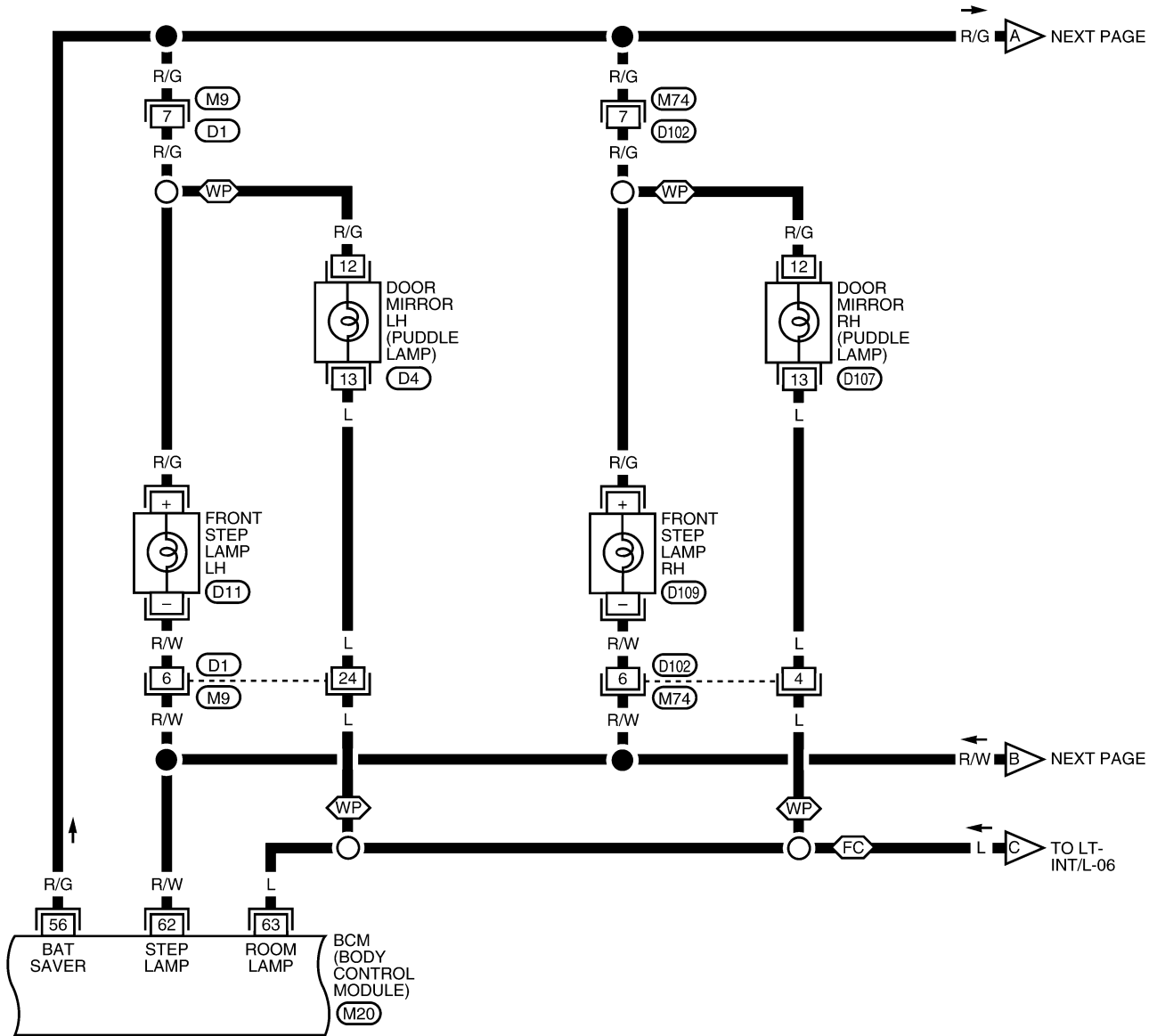

WKWA3782E

# INTERIOR ROOM LAMP

LT-INT/L-05

CC : CREW CAB  
FT : WITH FOOT LAMPS

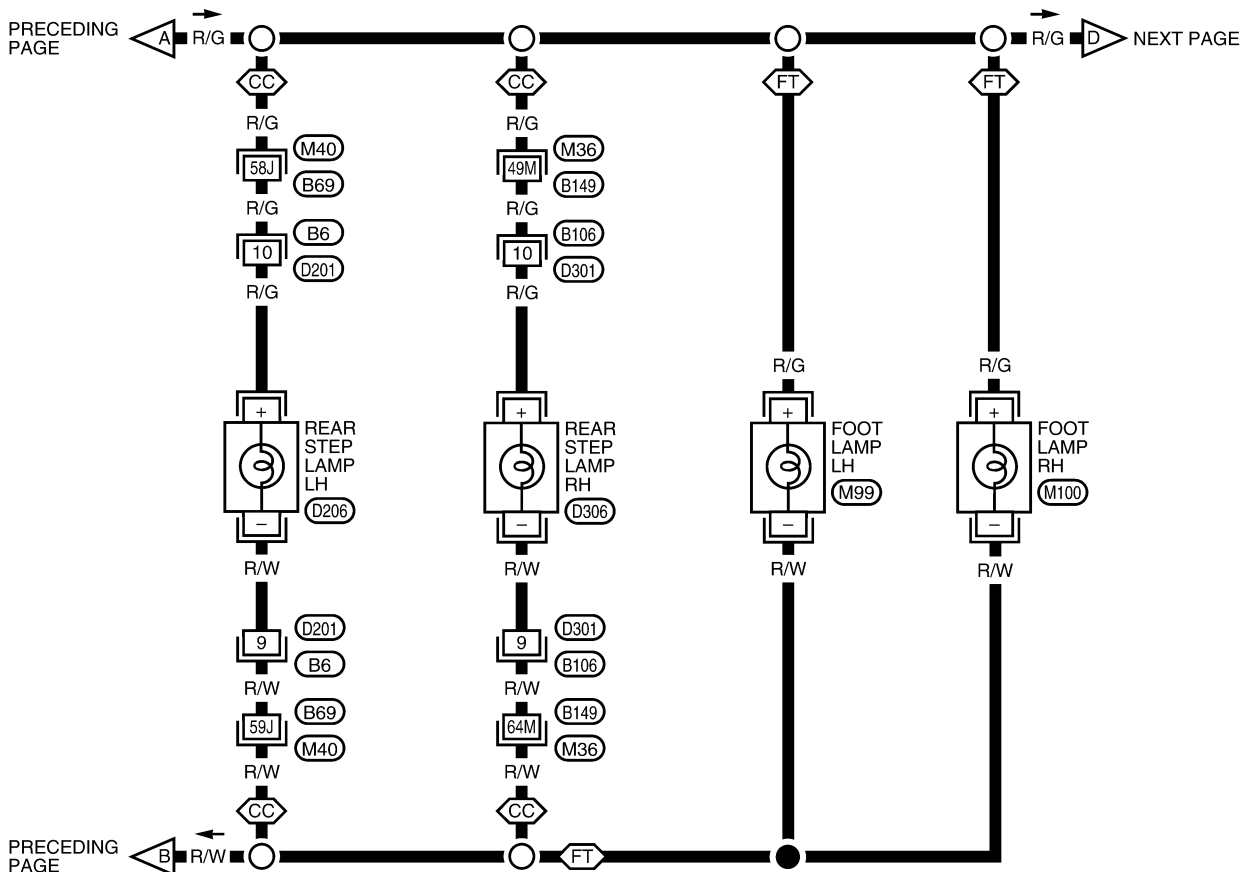

PRECEDING PAGE

NEXT PAGE

A  
B  
C  
D  
E  
F  
G  
H  
I  
J  
LT  
L  
M

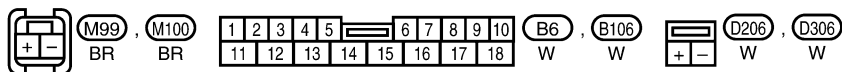

REFER TO THE FOLLOWING.  
M36 , M40 - SUPER  
 MULTIPLE JUNCTION (SMJ)

WKWA2450E

# INTERIOR ROOM LAMP

LT-INT/L-06

- ⬡FC : WITH FRONT ROOF CONSOLE
- ⬡RF : WITH REAR ROOF CONSOLE
- ⬡VN : WITH VANITY LAMPS

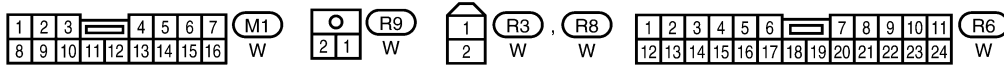
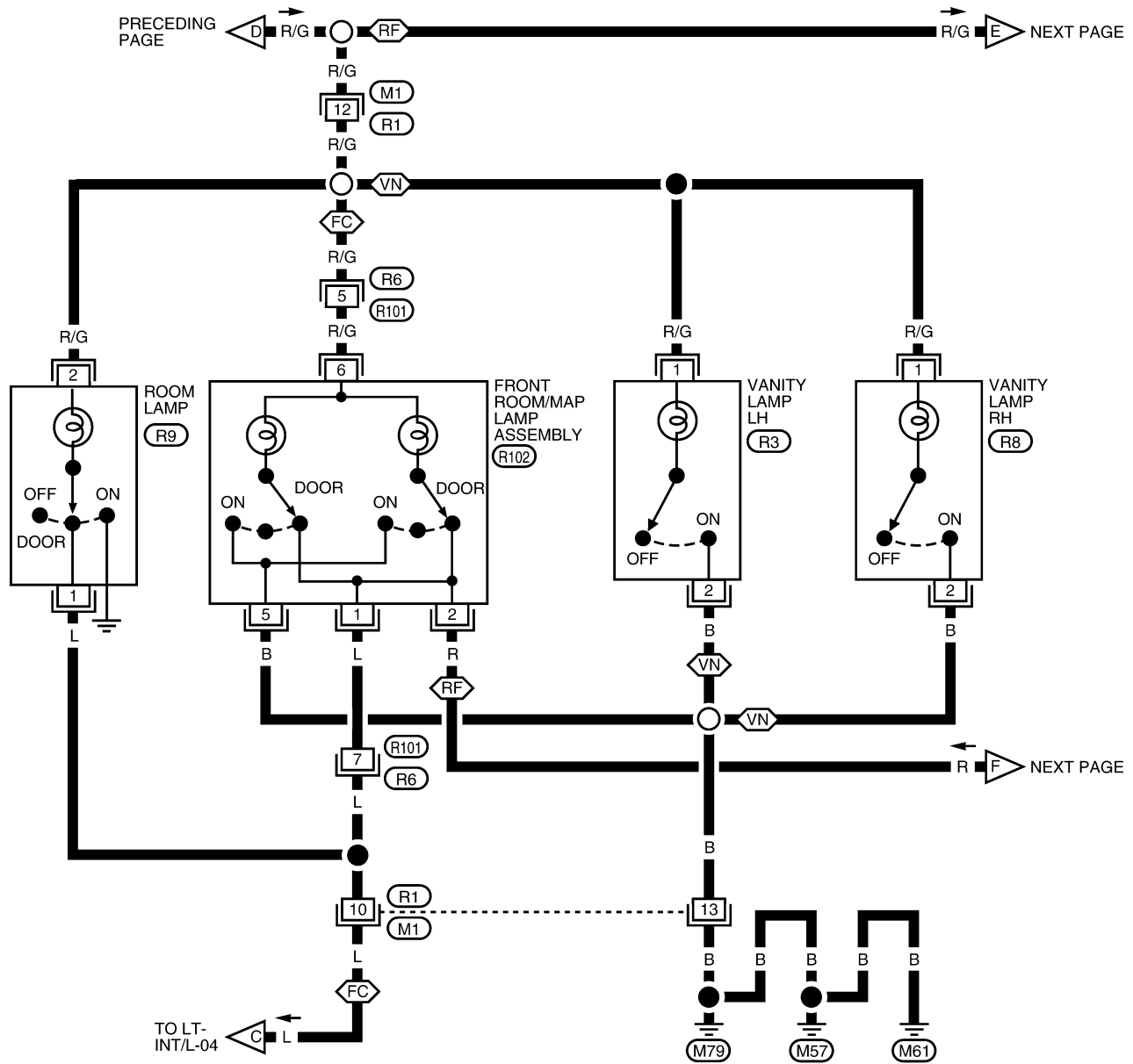

WKWA2451E



# INTERIOR ROOM LAMP

LT-INT/L-07

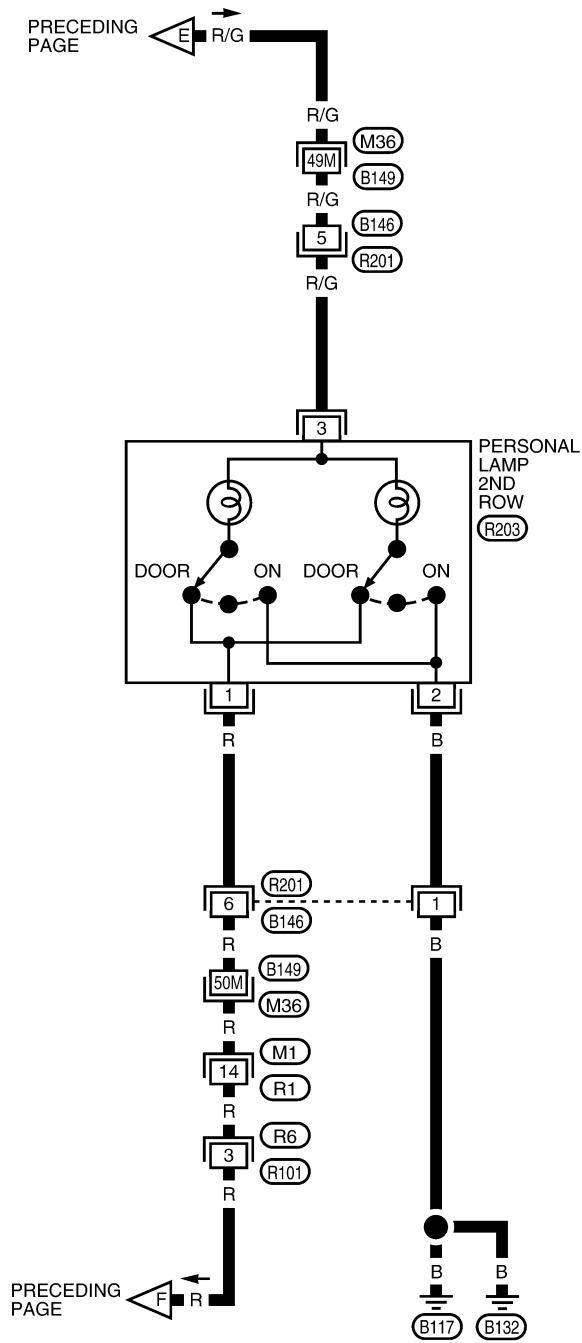

A  
B  
C  
D  
E  
F  
G  
H  
I  
J  
LT  
L  
M

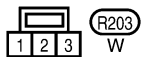
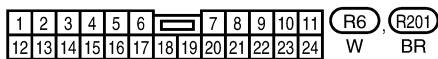
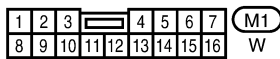

REFER TO THE FOLLOWING.  
**(M36)** - SUPER MULTIPLE JUNCTION (SMJ)

WKWA3783E

# INTERIOR ROOM LAMP

LT-INT/L-08

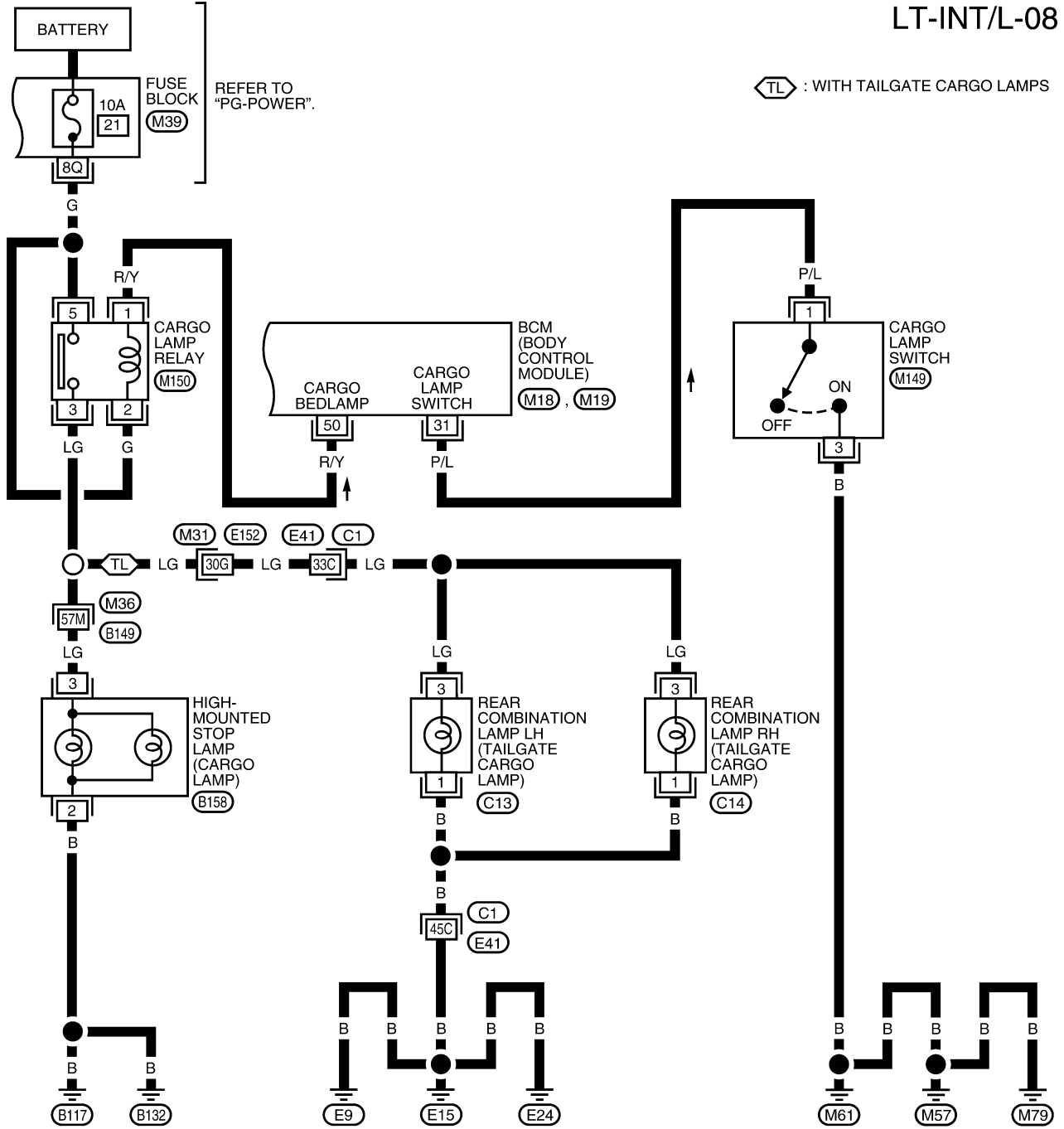

⬠ : WITH TAILGATE CARGO LAMPS



REFER TO THE FOLLOWING.  
 (M31), (M36), (C1) - SUPER  
 MULTIPLE JUNCTION (SMJ)

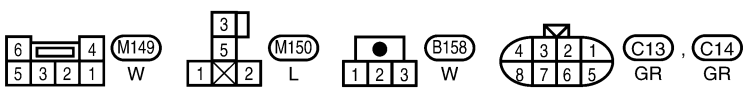
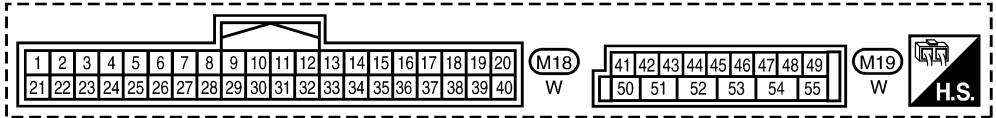

WKWA2471E

# INTERIOR ROOM LAMP

## Terminals and Reference Values for BCM

EKS00AC7

Refer to [BCS-12, "Terminals and Reference Values for BCM"](#) .

## How to Proceed With Trouble Diagnosis

EKS00AC8

1. Confirm the symptom or customer complaint.
2. Understand operation description and function description. Refer to [LT-108, "System Description"](#) .
3. Carry out the Preliminary Check. Refer to [LT-123, "Preliminary Check"](#) .
4. Check symptom and repair or replace the component.
5. Does the interior room lamp operate normally? If YES: GO TO 6. If NO: GO TO 4.
6. Inspection End.

## Preliminary Check

EKS00AC9

### CHECK POWER SUPPLY AND GROUND CIRCUIT TO BCM

Refer to [BCS-16, "BCM Power Supply and Ground Circuit Check"](#) .

## CONSULT-II Function (BCM)

EKS00ACA

Refer to [BCS-18, "CONSULT-II Function \(BCM\)"](#) .

## CONSULT-II START PROCEDURE

Refer to [GI-38, "CONSULT-II Start Procedure"](#) .

## WORK SUPPORT

### Display Item List

Item	Description	CONSULT-II
SET I/L D-UNLCK INTCON	The 30 seconds operating function of the interior room lamps can be selected when driver door is released (unlocked).	ON/OFF
ROOM LAMP ON TIME SET	The time in order to escalate illumination can be adjusted when the interior room lamps are turned on.	MODE 1 - 7
ROOM LAMP OFF TIME SET	The time in order to diminish illumination can be adjusted when the interior room lamps are turned off.	MODE 1 - 7

Reference between "MODE" and "TIME" for "TURN ON/OFF".

MODE	1	2	3	4	5	6	7
Time (sec.)	0.5	1	2	3	4	5	0

## DATA MONITOR

### Display Item List

Monitor item	Contents
IGN ON SW	"ON/OFF" Displays "IGN position (ON)/OFF, ACC position (OFF)" judged from the ignition switch signal.
KEY ON SW	"ON/OFF" Displays "Key inserted (ON)/key removed (OFF)" status judged from the key switch signal.
DOOR SW-DR	"ON/OFF" Displays status of the driver door as judged from the driver door switch signal. (Door is open: ON/Door is closed: OFF)
DOOR SW-AS	"ON/OFF" Displays "Door open (ON)/Door closed (OFF)" status, determined from passenger door switch signal.
DOOR SW-RR	"ON/OFF" Displays "Door open (ON)/Door closed (OFF)" status, determined from rear door switch RH signal.
DOOR SW-RL	"ON/OFF" Displays "Door open (ON)/Door closed (OFF)" status, determined from rear door switch LH signal.
BACK DOOR SW	"ON/OFF" Not used.
KEY CYL LK-SW	"ON/OFF" Displays "Door locked (ON)" status, determined from key cylinder lock switch in driver door.
KEY CYL UN-SW	"ON/OFF" Displays "Door unlocked (OFF)" status, determined from key cylinder lock switch in driver door.

# INTERIOR ROOM LAMP

Monitor item	Contents
CDL LOCK SW "ON/OFF"	Displays "Door locked (ON)/Door unlocked (OFF)" status, determined from locking detection switch in driver door.
CDL UNLOCK SW "ON/OFF"	Displays "Door unlocked (OFF)" status, determined from locking detection switch in passenger door.
KEYLESS LOCK "ON/OFF"	Displays "Locked (ON)/Other (OFF)" status, determined from lock signal.
KEYLESS UNLOCK "ON/OFF"	Displays "Unlocked (ON)/Other (OFF)" status, determined from unlock signal.

## ACTIVE TEST

### Display Item List

Test item	Description
INT LAMP	Interior room lamp can be operated by any ON-OFF operations.
IGN ILLUM <sup>NOTE</sup>	Ignition keyhole illumination can be operated by ON-OFF operation.

NOTE: This item is displayed but this model is not equipped.

## Front Room/Map Lamp Assembly Control Does Not Operate

EKS00ACB

### 1. CHECK EACH SWITCH

Select "BCM" on CONSULT-II. With "INT LAMP" data monitor, make sure switches listed in display item list turn ON-OFF linked with switch operation. Refer to [LT-123, "Display Item List"](#) for switches and their functions.

#### OK or NG

- OK >> GO TO 2.
- NG >> Inspect malfunctioning switch system.

DATA MONITOR	
MONITOR	
IGN ON SW	ON
KEY ON SW	ON
DOOR SW-DR	ON
DOOR SW-AS	ON
DOOR SW-RR	OFF
DOOR SW-RL	OFF
BACK DOOR SW	OFF
KEY CYL LK-SW	OFF
KEY CYL UN-SW	OFF

SKIA5930E

### 2. ACTIVE TEST

- Select "BCM" on CONSULT-II. Select "INT LAMP" active test.
- When switch is in DOOR position, use active test to make sure front room/map lamp operates.

**Room lamps should turn on.**

#### OK or NG

- OK >> Replace BCM. Refer to [BCS-26, "BCM"](#).
- NG >> GO TO 3.

ACTIVE TEST	
INT LAMP	ON
	OFF

LKIA0092E

### 3. CHECK FRONT ROOM/MAP LAMP ASSEMBLY INPUT

- Turn ignition switch OFF.
- Check voltage between front room/map lamp assembly harness connector R102 terminal 6 and ground.

**6 - Ground : Battery voltage should exist.**

#### OK or NG

- OK >> GO TO 4.
- NG >> GO TO 5.

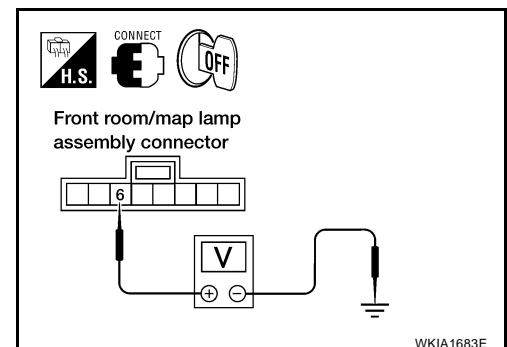

# INTERIOR ROOM LAMP

## 4. CHECK FRONT ROOM/MAP LAMP ASSEMBLY CIRCUIT

1. Disconnect BCM connector.
2. Check continuity between BCM harness connector M20 terminal 63 and front room/map lamp assembly harness connector R102 terminal 1.

**63 - 1** : Continuity should exist.

OK or NG

- OK >> Replace front room/map lamp assembly.
- NG >> Repair harness or connector.

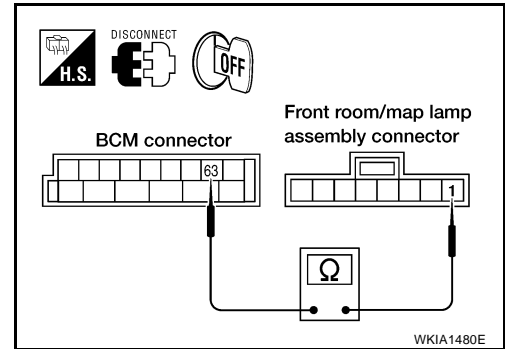

## 5. CHECK FRONT ROOM/MAP LAMP INPUT CIRCUIT

1. Disconnect BCM connector and front room/map lamp connector.
2. Check continuity between BCM harness connector M20 terminal 56 and front room/map lamp assembly harness connector R102 terminal 6.

**56 - 6** : Continuity should exist.

OK or NG

- OK >> Replace BCM if front room/map lamp does not work after setting the connector again. Refer to [BCS-26, "BCM"](#).
- NG >> Repair harness or connector between BCM and front room/map lamp.

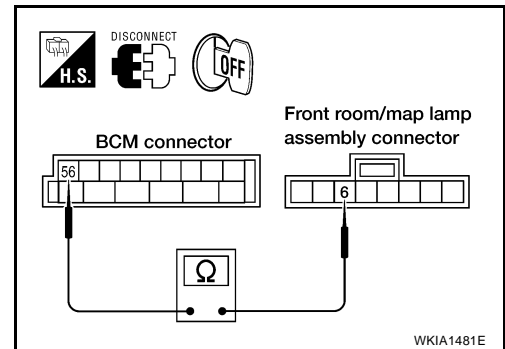

A  
B  
C  
D  
E  
F  
G  
H  
I  
J  
LT  
L  
M

# INTERIOR ROOM LAMP

## Personal Lamp 2nd Row Control Does Not Operate (Room/Map Lamps Operate)

EKS00ACC

### 1. CHECK EACH DOOR SWITCH

Select "BCM" on CONSULT-II. With "INT LAMP" data monitor, make sure switches listed in display item list turn ON-OFF linked with switch operation. Refer to [LT-109, "SWITCH OPERATION"](#) for switches and their functions.

OK or NG

- OK >> GO TO 2.
- NG >> Inspect malfunctioning door switch.

DATA MONITOR	
MONITOR	
IGN ON SW	ON
KEY ON SW	ON
DOOR SW-DR	ON
DOOR SW-AS	ON
DOOR SW-RR	OFF
DOOR SW-RL	OFF
BACK DOOR SW	OFF
KEY CYL LK-SW	OFF
KEY CYL UN-SW	OFF

SKIA5930E

### 2. CHECK PERSONAL LAMP 2ND ROW OUTPUT

1. Turn ignition switch OFF.
2. Confirm lamp switch is in the DOOR position.
3. Disconnect personal lamp 2nd row connector.
4. Open any door.
5. Check voltage between personal lamp 2nd row harness connector R203 terminal 3 and ground.

**3 - Ground : Battery voltage should exist.**

OK or NG

- OK >> GO TO 3.
- NG >> Repair harness or connector.

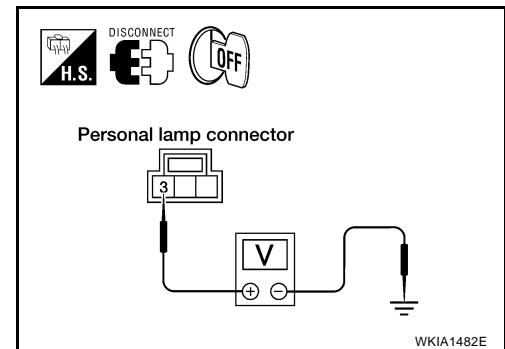

### 3. CHECK PERSONAL LAMP 2ND ROW CONTROL CIRCUIT

1. Disconnect front room/map lamp assembly connector.
2. Check continuity between front room/map lamp assembly harness connector R102 terminal 2 and personal lamp 2nd row harness connector R203 terminal 1.

**2 - 1 : Continuity should exist.**

OK or NG

- OK >> Replace personal lamp 2nd row.
- NG >> Repair harness or connector.

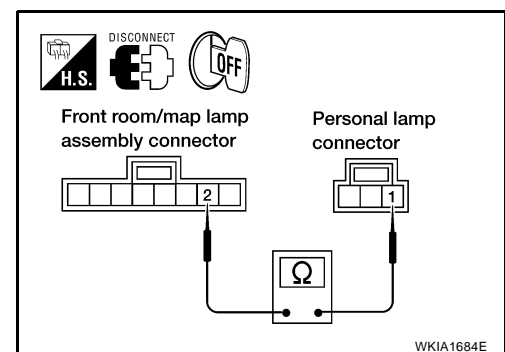

# INTERIOR ROOM LAMP

EKS00ACD

## All Step/Foot/Puddle Lamps Do Not Operate

### 1. CHECK EACH DOOR SWITCH

Select "BCM" on CONSULT-II. With "INT LAMP" data monitor, make sure switches listed in display item list turn ON-OFF linked with switch operation. Refer to [LT-123, "Display Item List"](#) for switches and their functions.

OK or NG

- OK >> GO TO 2.
- NG >> Inspect malfunctioning switch system.

DATA MONITOR	
MONITOR	
IGN ON SW	ON
KEY ON SW	ON
DOOR SW-DR	ON
DOOR SW-AS	ON
DOOR SW-RR	OFF
DOOR SW-RL	OFF
BACK DOOR SW	OFF
KEY CYL LK-SW	OFF
KEY CYL UN-SW	OFF

SKIA5930E

### 2. CHECK STEP LAMP POWER SUPPLY

- Turn ignition switch OFF.
- Check voltage between front step lamp LH harness connector D11 terminal + and ground.

**+ - Ground** : Battery voltage should exist.

OK or NG

- OK >> GO TO 3.
- NG >> GO TO 4.

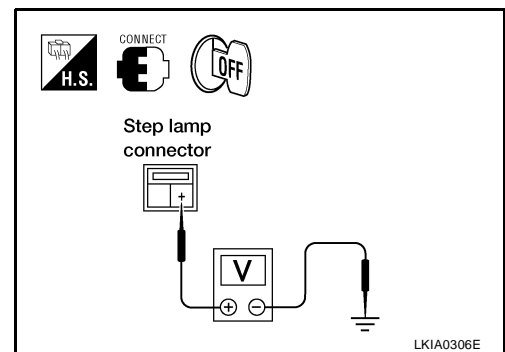

### 3. CHECK STEP LAMP CONTROL CIRCUIT

- Disconnect BCM connector and front step lamp LH connector.
- Check continuity between BCM harness connector M20 terminal 62 and front step lamp LH harness connector D11 terminal -.

**- - 62** : Continuity should exist.

OK or NG

- OK >> Replace BCM if front step lamp does not work after setting the connector again. Refer to [BCS-26, "BCM"](#).
- NG >> Repair harness or connector.

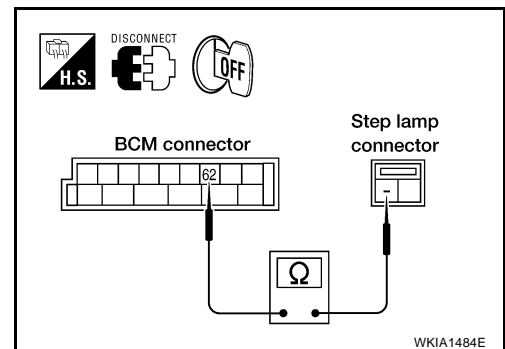

### 4. CHECK STEP LAMP CIRCUIT

- Disconnect BCM connector and front step lamp LH connector.
- Check continuity between BCM harness connector M20 terminal 56 and front step lamp LH harness connector D11 terminal +.

**+ - 56** : Continuity should exist.

OK or NG

- OK >> Replace BCM if front step lamp does not work after setting the connector again. Refer to [BCS-26, "BCM"](#).
- NG >> Repair harness or connector.

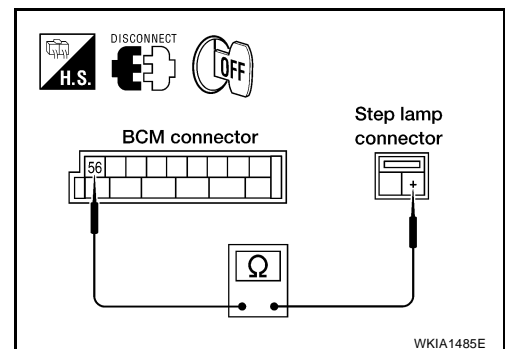

# INTERIOR ROOM LAMP

## All Interior Room Lamps Do Not Operate

EKS00ACE

### 1. CHECK POWER SUPPLY CIRCUIT

1. All interior room lamp switches are OFF.
2. Turn ignition switch ON.
3. Check voltage between BCM harness connector M20 terminal 56 and ground.

**56 - Ground : Battery voltage should exist.**

#### OK or NG

- OK >> Repair harness or connector. to prevent making a short circuit, be sure to disconnect battery negative cable after repairing harness, and then reconnect.
- NG >> Replace BCM. Refer to [BCS-26, "BCM"](#) .

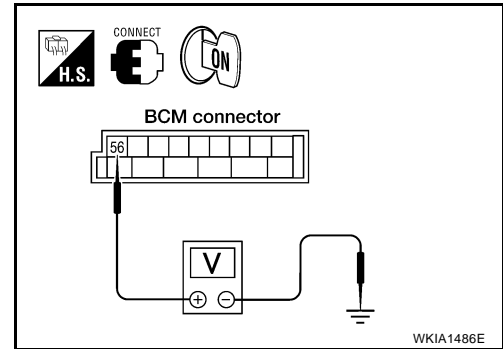



## ILLUMINATION

## Component Parts and Harness Connector Location

EKS00ACF

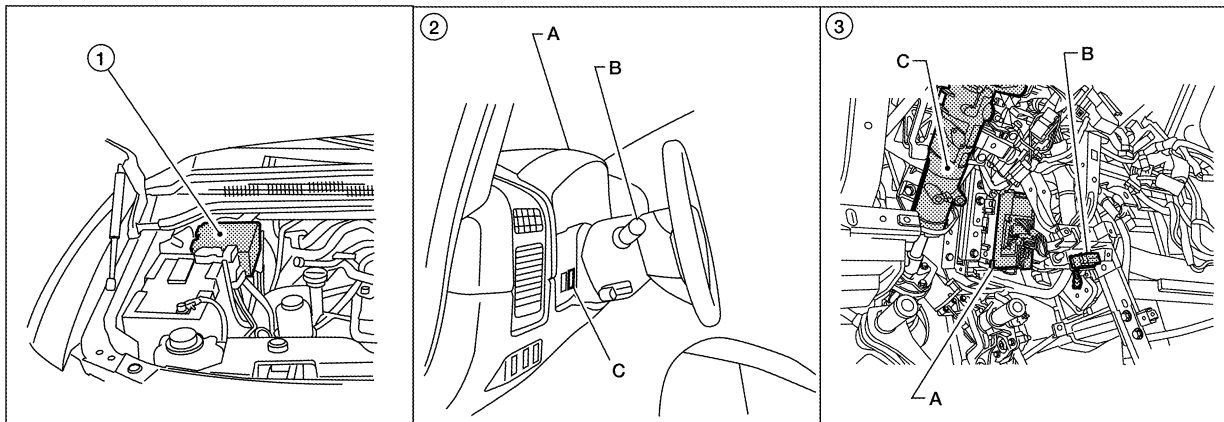

WKIA5600E

1. IPDM E/R E122, E123 and E124

2. A. Combination meter M24  
 B. Combination switch M28  
 C. Illumination control switch M5

3. A. BCM M18 and M20  
 B. Data link connector M22  
 C. Steering column (view with instrument lower panel LH removed)

## System Description

EKS00ACG

Control of the illumination lamps operation is dependent upon the position of the lighting switch (combination switch). When the lighting switch is placed in the 1ST or 2ND position (or if the auto light system is activated) the BCM (body control module) receives input signal requesting the illumination lamps to illuminate. This input signal is communicated to the IPDM E/R (intelligent power distribution module engine room) across the CAN communication lines. The CPU (central processing unit) of the IPDM E/R controls the tail lamp relay coil. This relay, when energized, directs power to the illumination lamps, which then illuminate. Power is supplied at all times

- to ignition relay, located in the IPDM E/R.
- to tail lamp relay, located in the IPDM E/R, and
- through 50A fusible link (letter f , located in the fuse and fusible link box)
- to BCM terminal 70, and
- through 20A fuse (No. 53, located in the IPDM E/R)
- to CPU of the IPDM E/R, and
- through 10A fuse [No.19, located in fuse block (J/B)]
- to combination meter terminal 8.

With the ignition switch in the ON or START position, power is supplied

- to ignition relay, located in the IPDM E/R, and
- through 10A fuse (No. 59, located in the fuse and relay box)
- to BCM terminal 38, and
- through 10A fuse [No. 14, located in the fuse block (J/B)]
- to combination meter terminal 24.

Ground is supplied

- to BCM terminal 67
- to combination meter terminal 17
- through grounds M57, M61, and M79, and
- to IPDM E/R terminals 38 and 59
- through grounds E9, E15 and E24.

A  
B  
C  
D  
E  
F  
G  
H  
I  
J

LT

L

M

# ILLUMINATION

---

## ILLUMINATION OPERATION BY LIGHTING SWITCH

With the lighting switch in the 1ST or 2ND position (or if the auto light system is activated), the BCM receives input signal requesting the illumination lamps to illuminate. This input signal is communicated to the IPDM E/R across the CAN communication lines. The CPU of the IPDM E/R controls the tail lamp relay coil, which, when energized, directs power

- through 10A fuse (No. 36, located in the IPDM E/R)
- through IPDM E/R terminal 49
- to illumination control switch terminal 1
- to VDC OFF switch terminal 3 (with VDC)
- to front room/map lamp assembly (console box illumination) terminal 7
- to AV switch terminal 3 (except base audio system)
- to hazard switch terminal 7
- to audio unit terminal 8
- to differential lock mode switch terminal 4 (with electronic locking rear differential)
- to rear sonar system OFF switch terminal 3 (with rear sonar system)
- to glove box lamp terminal 1 (with glove box lamp)
- to door mirror remote control switch terminal 16 (with power door mirrors)
- to display control unit terminal 14 (with NAVI)
- to compass and thermometer terminal 14 (with overhead compass)
- to 4WD shift switch terminal 7 (with 4-wheel drive)
- to front air control terminal 8 (front air control with display) or terminal 23 (front air control without display)
- to cargo lamp switch terminal 4
- to DVD player terminal 12 (with DVD entertainment system)
- to NAVI control unit terminal 61 (with NAVI)
- to power window and door lock/unlock switch RH terminal 5 (with power windows)
- to main power window and door lock/unlock switch LH terminal 16 (with power windows)
- to pedal adjusting switch terminal 5
- to electric brake (pre-wiring) terminal 4 (with trailer tow)
- to A/T device terminal 11 (with floor shift)
- to heated seat switch LH and RH terminal 5 (with heated seats)
- to rear power drop glass switch terminal 4 (with rear power drop glass)
- to tow mode switch terminal 3, and
- through 10A fuse (No. 37, located in the IPDM E/R)
- through IPDM E/R terminal 57
- to rear audio remote control unit terminal 6 (with rear audio remote control unit).

Illumination ground is controlled

- through illumination control switch terminal 2
- to VDC OFF switch terminal 4 (with VDC)
- to front room/map lamp assembly (console box illumination) terminal 8
- to AV switch terminal 4 (except base audio system)
- to hazard switch terminal 8
- to audio unit terminal 7
- to differential lock mode switch terminal 5 (with electronic locking rear differential)
- to rear sonar system OFF switch terminal 4 (with rear sonar system)
- to door mirror remote control switch terminal 15 (with power door mirrors)
- to 4WD switch terminal 8 (with 4-wheel drive)
- to front air control terminal 9 (front air control with display) or terminal 24 (front air control without display)
- to cargo lamp switch terminal 2
- to DVD player terminal 10 (with DVD entertainment system)

# ILLUMINATION

- to pedal adjusting switch terminal 6
- to power window and door lock/unlock switch RH terminal 1 (with power windows)
- to main power window and door lock/unlock switch LH terminal 12 (with power windows)
- to A/T device terminal 12 (with floor shift)
- to heated seat switch LH and RH terminal 6 (with heated seats)
- to tow mode switch terminal 4
- to rear power drop glass switch terminal 2 (with rear power drop glass) and
- to combination meter terminal 18.

Ground is supplied

- to illumination control switch terminal 3
- to glove box lamp terminal 2 (with glove box lamp)
- to display control unit terminal 3 (with NAVI) and
- to electric brake (pre-wiring) terminal 1 (with trailer tow) and
- to compass and thermometer terminal 7 (with overhead compass)
- through grounds M57, M61 and M79, and
- to NAVI control unit terminal 1 (with NAVI) and
- to rear audio remote control unit terminal 15 (with rear audio remote control unit)
- through grounds B117 and B132.

With power and ground supplied, illumination lamps illuminate.

## EXTERIOR LAMP BATTERY SAVER CONTROL

When the combination switch (lighting switch) is in the 1ST or 2ND position (or if auto light system is activated), and the ignition switch is turned from ON or ACC to OFF, the battery saver control function is activated. Under this condition, the illumination lamps remain illuminated for 5 minutes, then the illumination lamps are turned off.

When the lighting switch is turned from OFF to 1ST or 2ND position (or if auto light system is activated) after illumination lamps are turned off by the battery saver control, the illumination lamps illuminate again. Exterior lamp battery saver control mode can be changed by the function setting of CONSULT-II.

## CAN Communication System Description

EKS00ACH

Refer to [LAN-2, "CAN Communication System"](#) .

A

B

C

D

E

F

G

H

I

J

LT

L

M

# ILLUMINATION

## Schematic

EKS00ACI

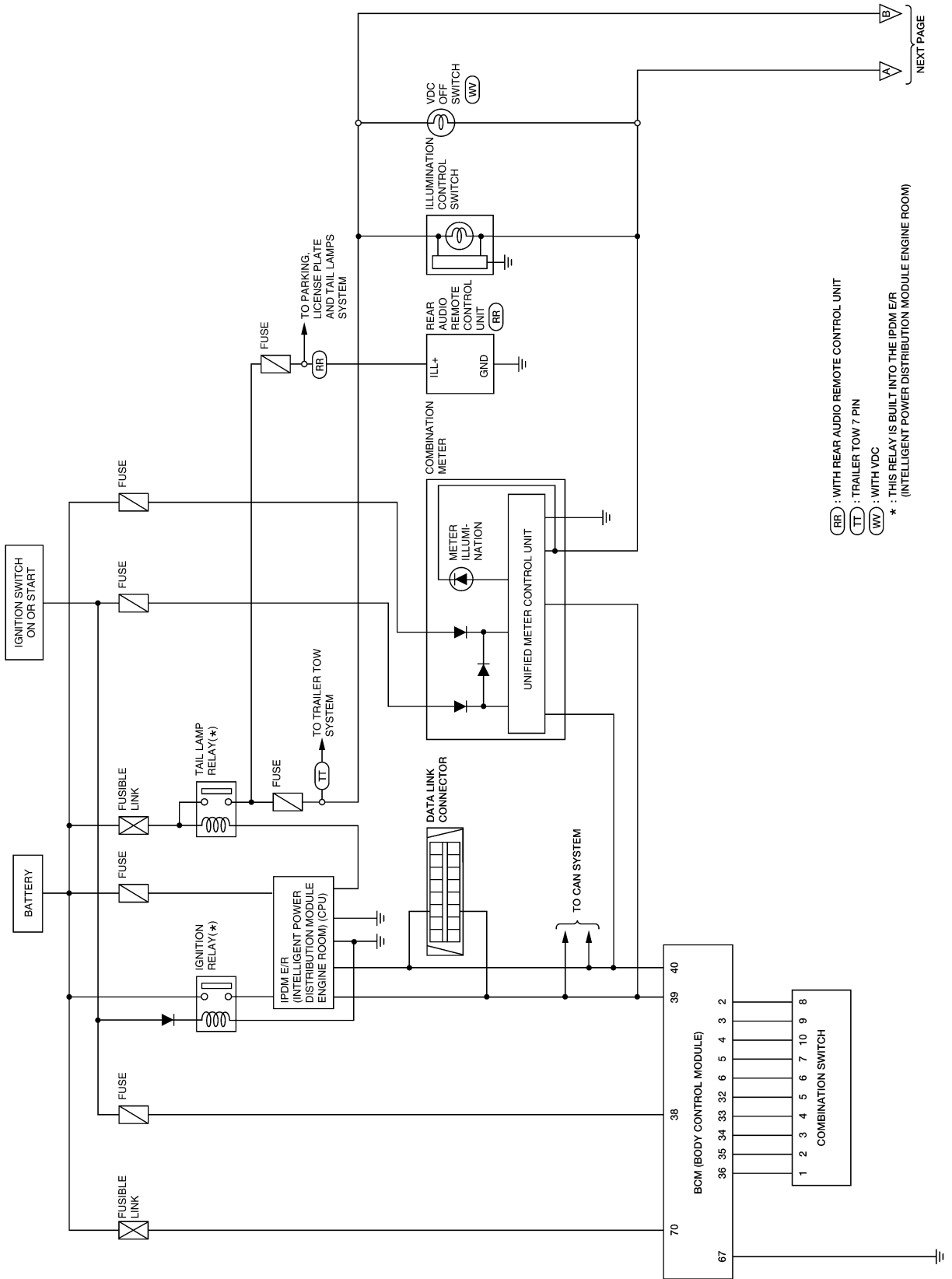

WKWA3784E

# ILLUMINATION

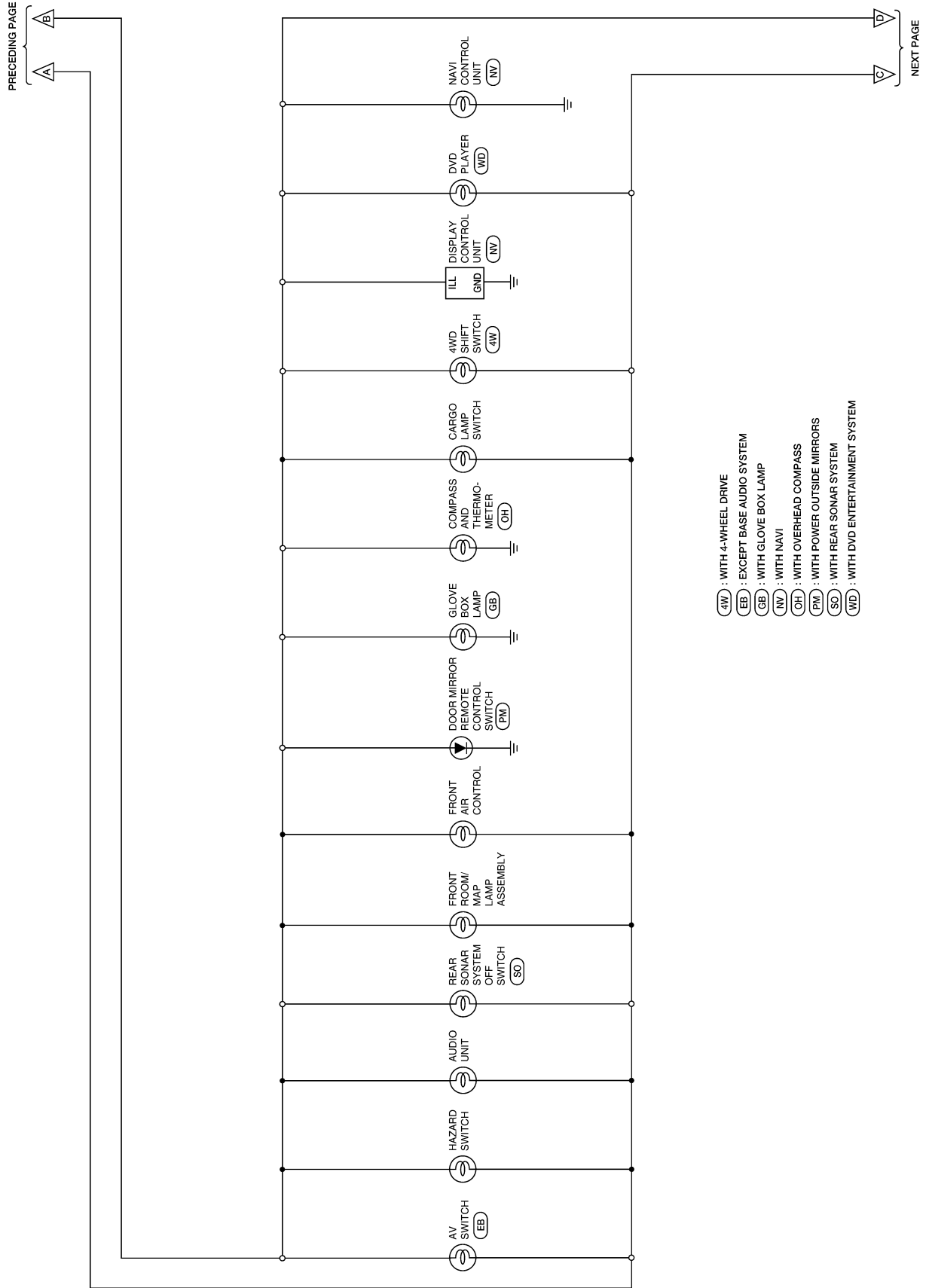

A  
B  
C  
D  
E  
F  
G  
H  
I  
J  
LT  
L  
M

# ILLUMINATION

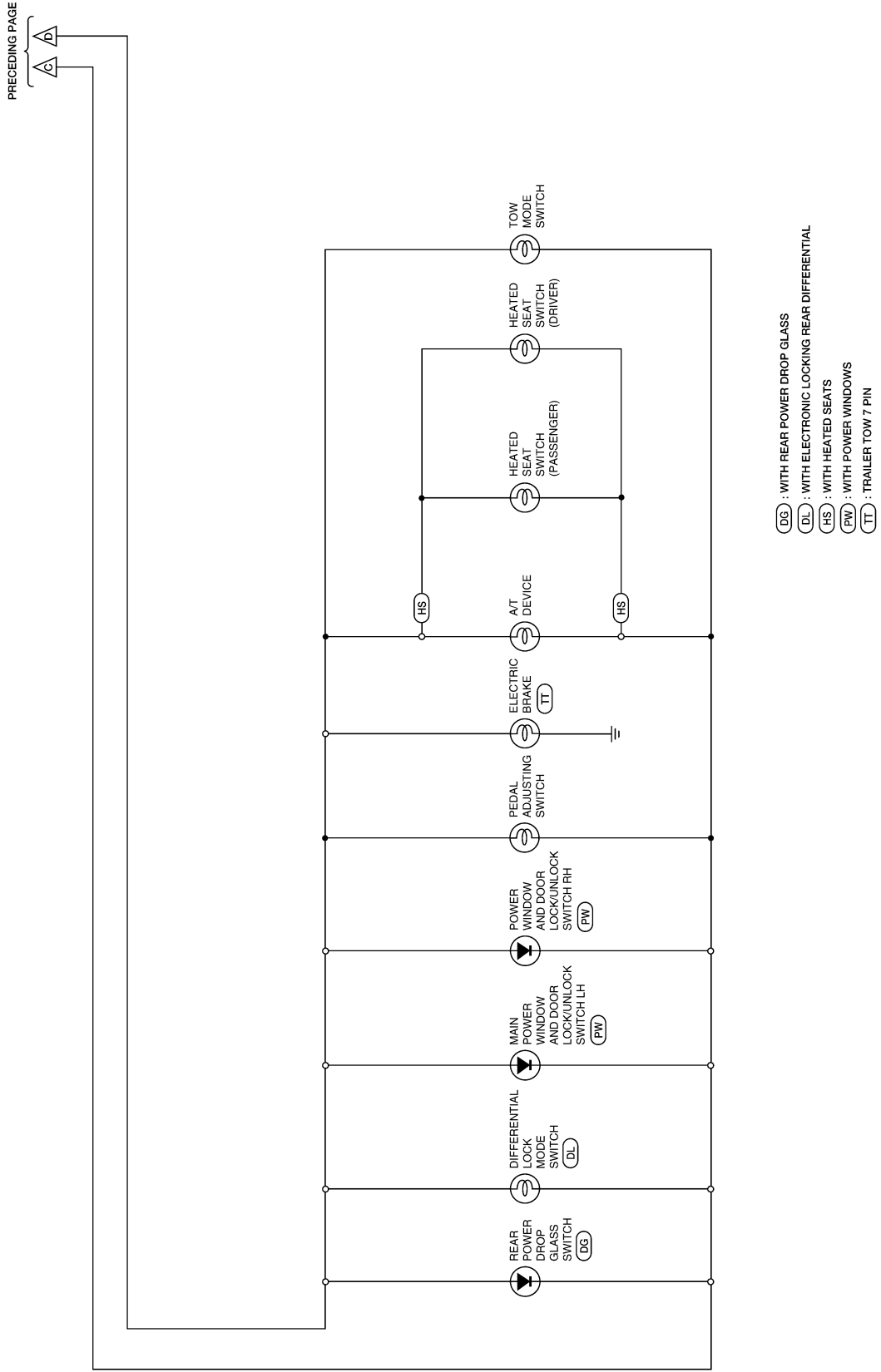

WKWA5156E

# ILLUMINATION

## Wiring Diagram — ILL —

EKS00ACJ

**LT-ILL-01**  
 : DATA LINE

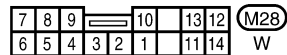
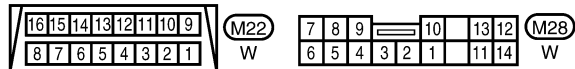
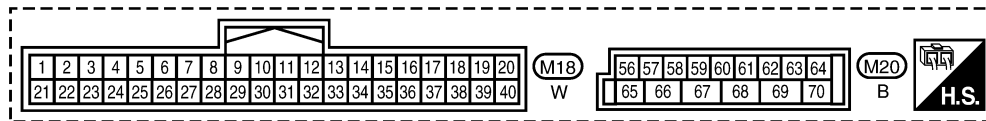
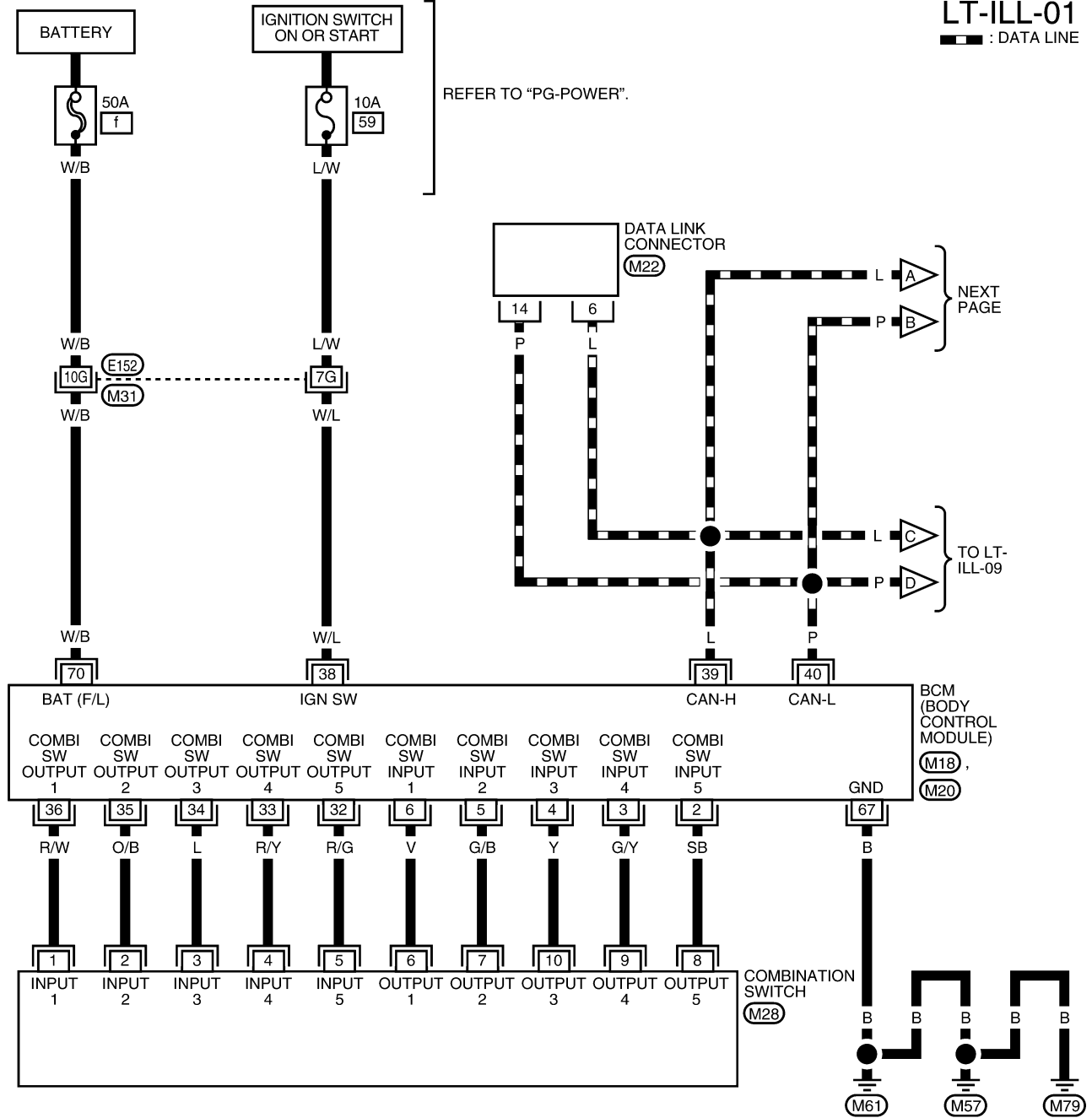

WKWA3787E

# ILLUMINATION

LT-ILL-02

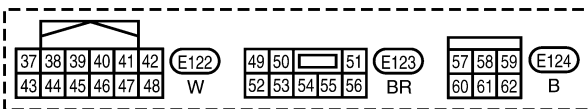
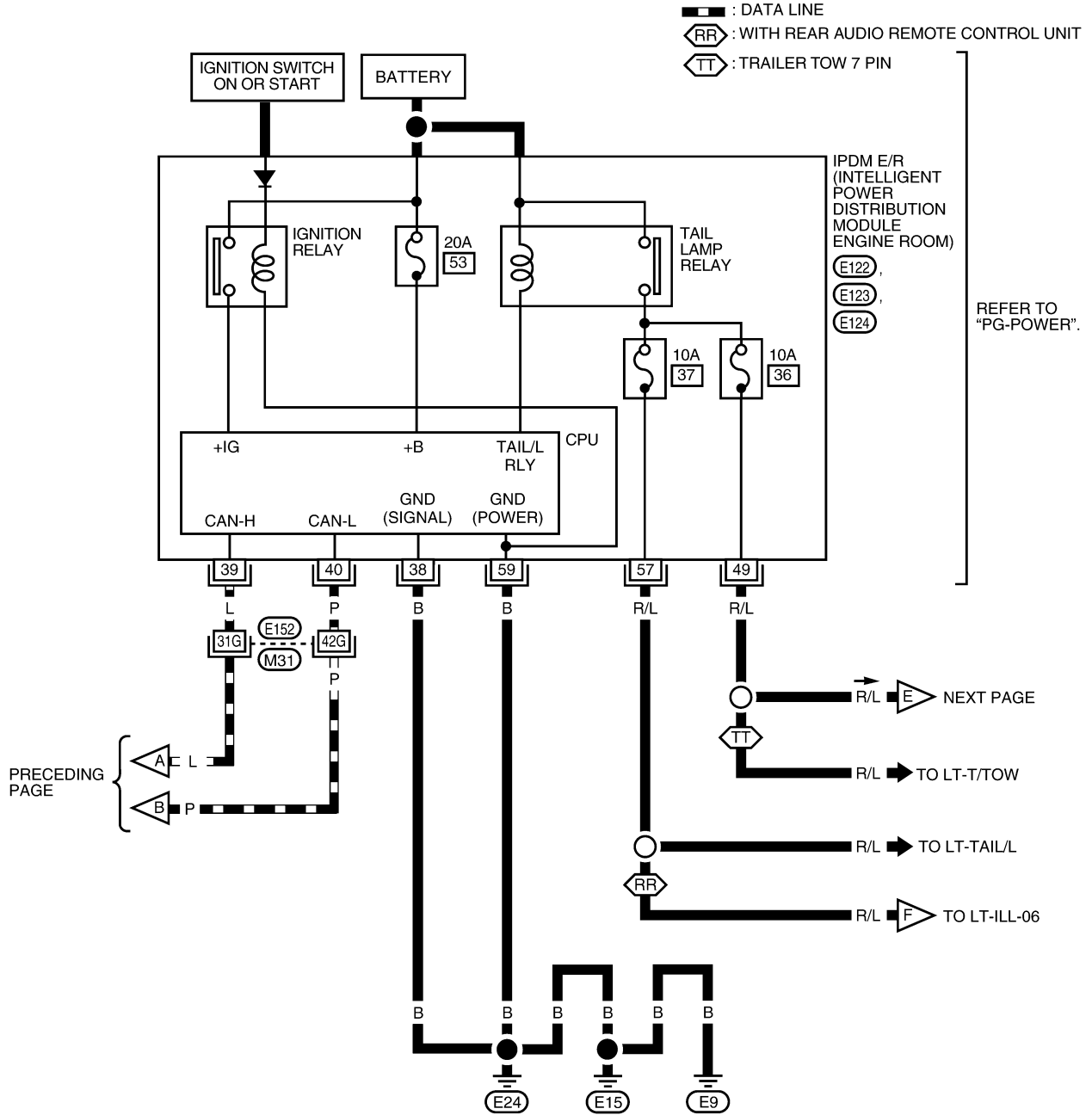

REFER TO THE FOLLOWING.  
M31 - SUPER MULTIPLE JUNCTION (SMJ)

WKWA3788E



# ILLUMINATION

LT-ILL-03

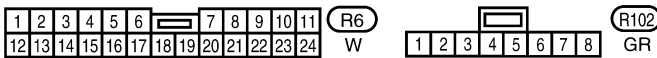
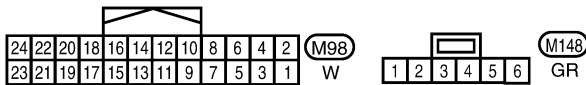
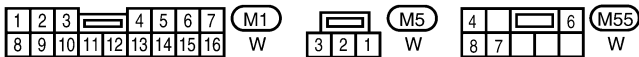
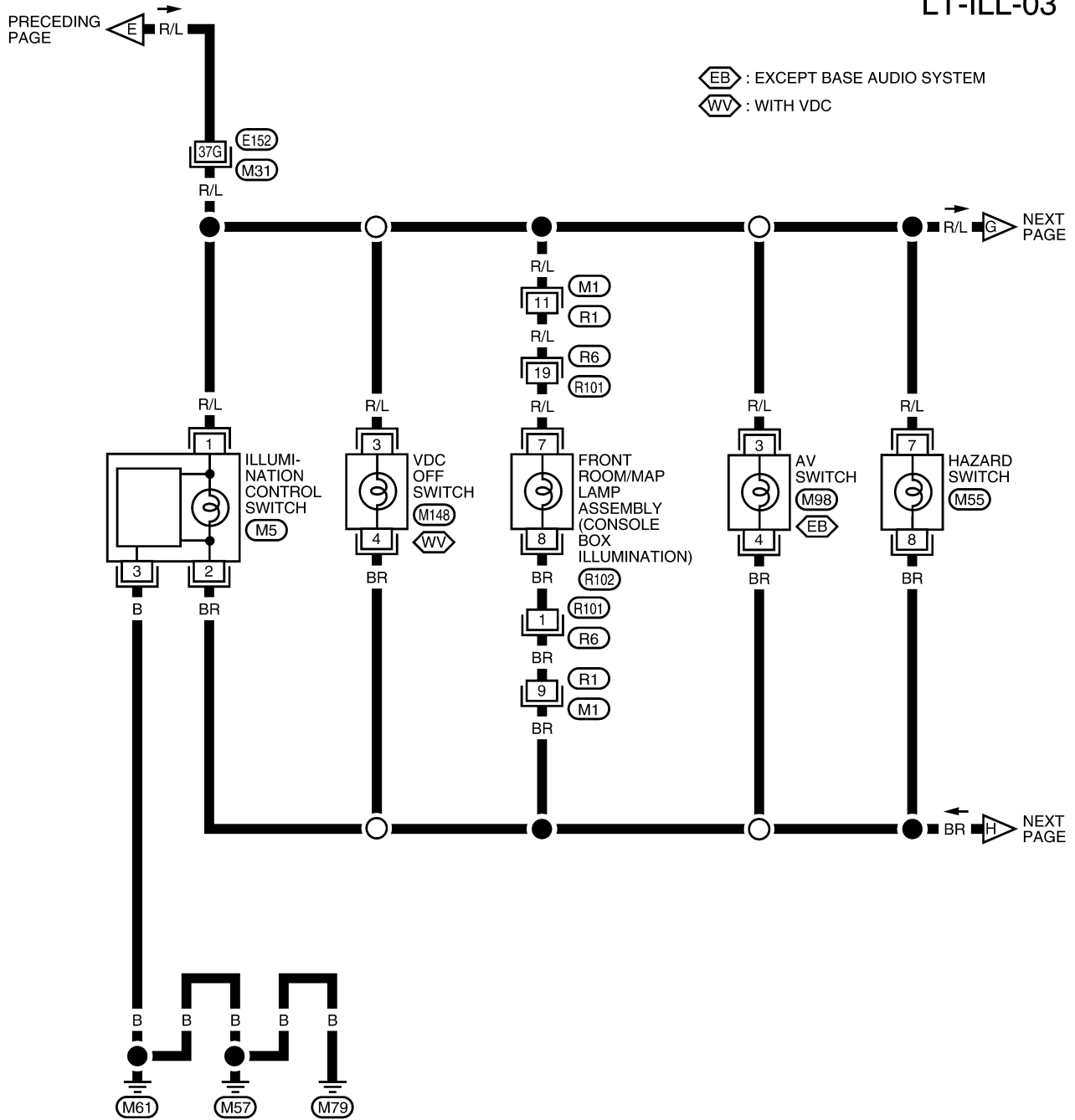

REFER TO THE FOLLOWING.  
 (M31) - SUPER MULTIPLE  
 JUNCTION (SMJ)

WKWA3789E

# ILLUMINATION

LT-ILL-04

- ⬠AD : WITH AUTOMATIC DRIVE POSITIONER
- ⬠DL : WITH ELECTRONIC LOCKING REAR DIFFERENTIAL
- ⬠GB : WITH GLOVE BOX LAMP
- ⬠PM : WITH POWER OUTSIDE MIRRORS
- ⬠SO : WITH REAR SONAR SYSTEM
- ⬠XA : WITHOUT AUTOMATIC DRIVE POSITIONER

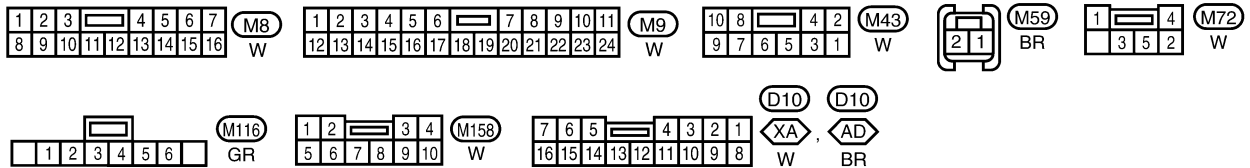
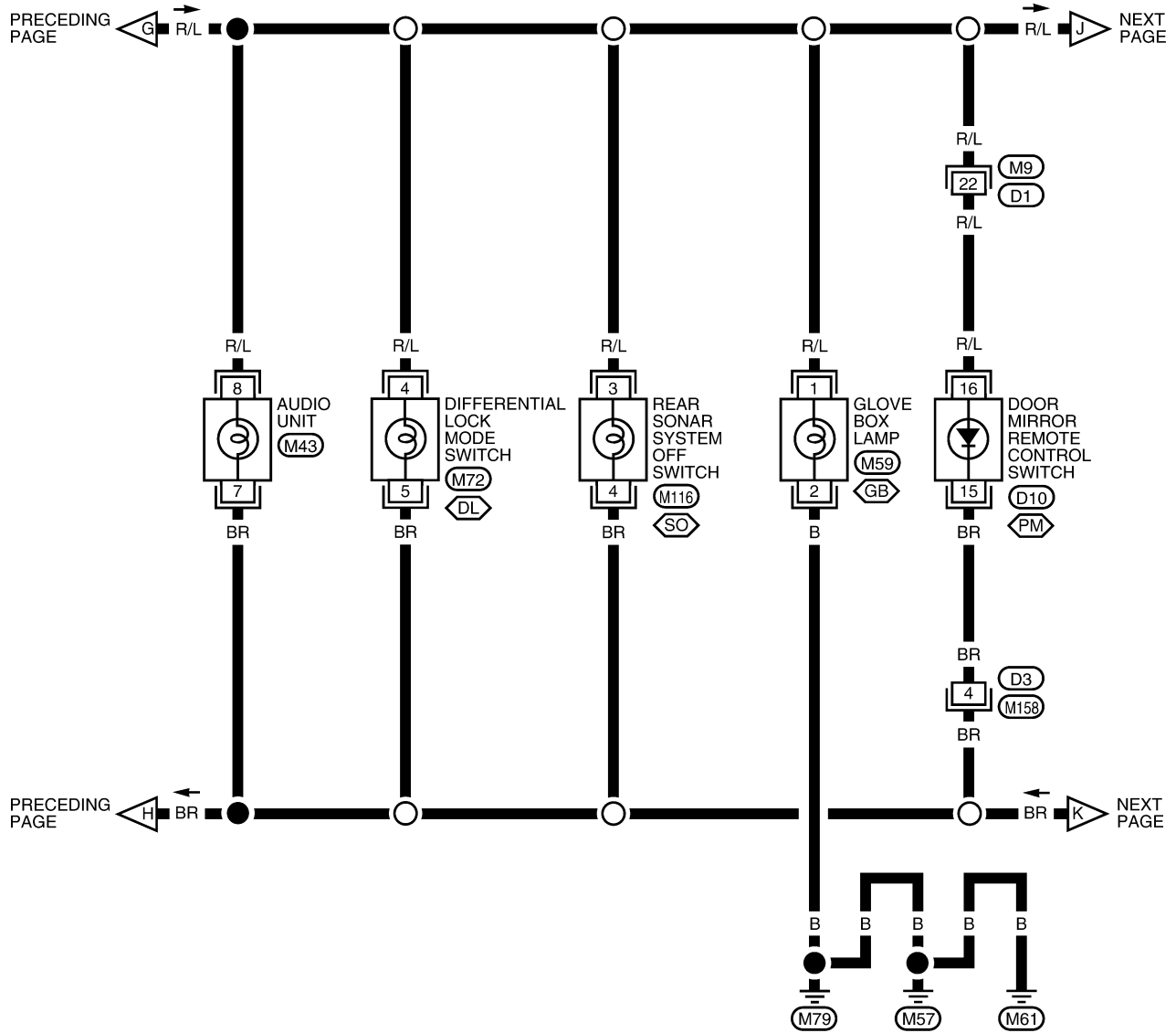

WKWA5157E

# ILLUMINATION

LT-ILL-05

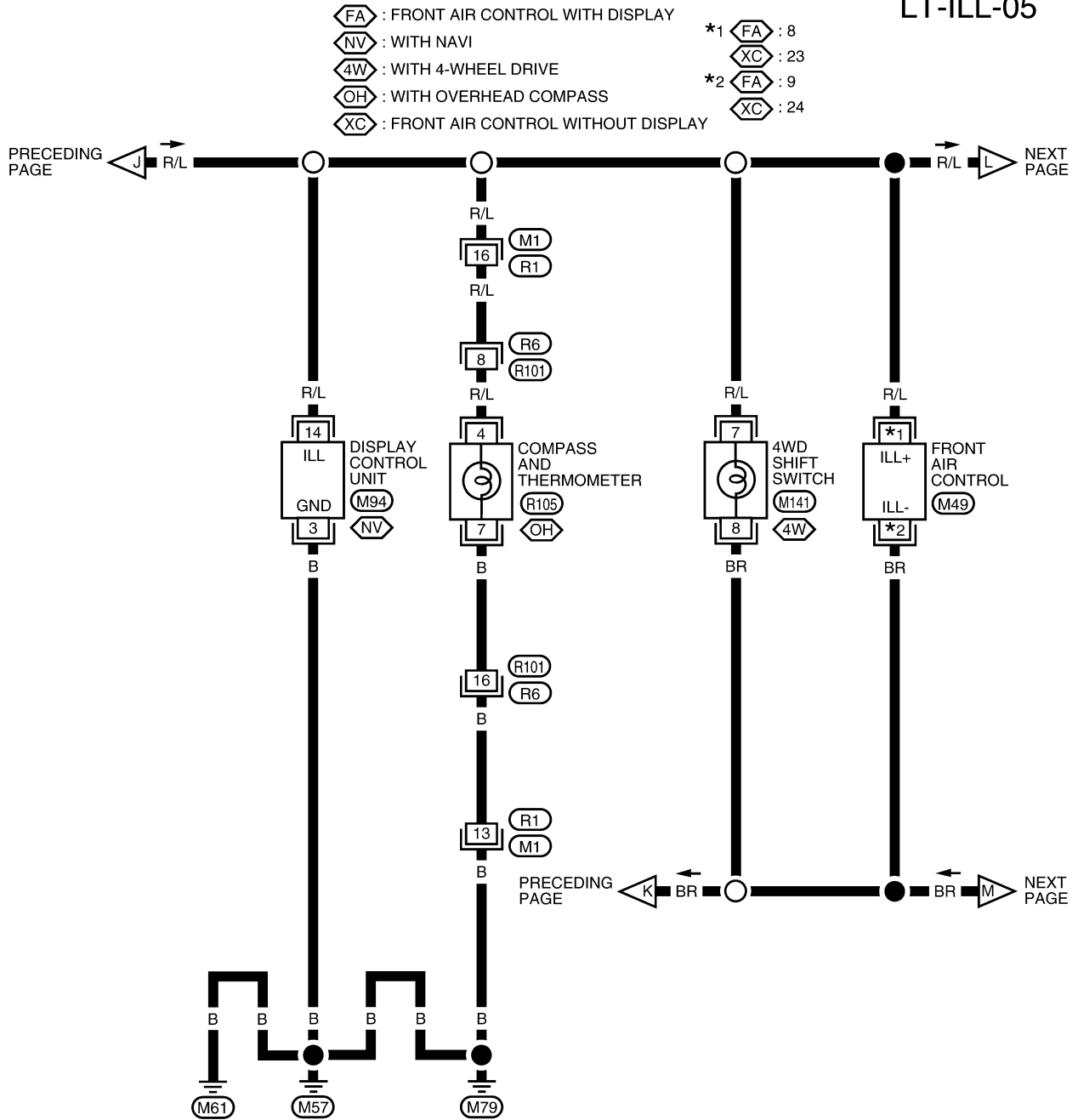

A  
B  
C  
D  
E  
F  
G  
H  
I  
J  
K  
L  
M

LT

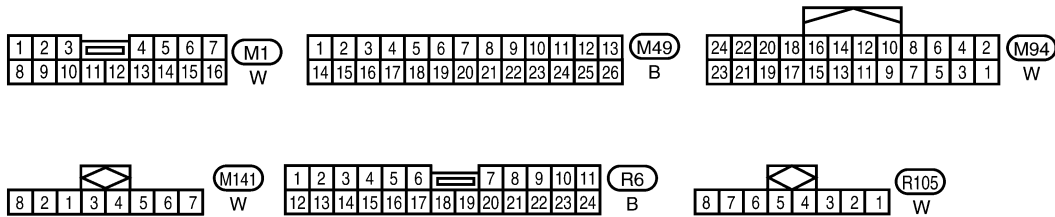

WKWA3791E

# ILLUMINATION

## LT-ILL-06

- : WITH NAVI
- : WITH DVD ENTERTAINMENT SYSTEM
- : WITH REAR AUDIO REMOTE CONTROL UNIT

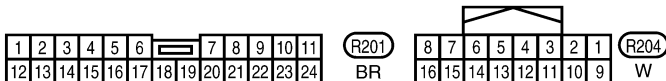
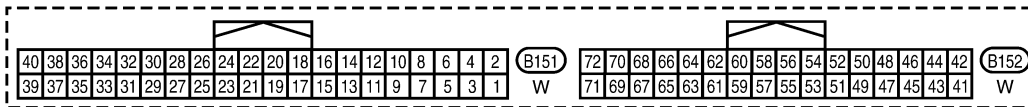
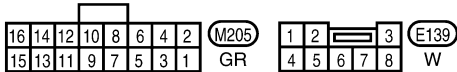
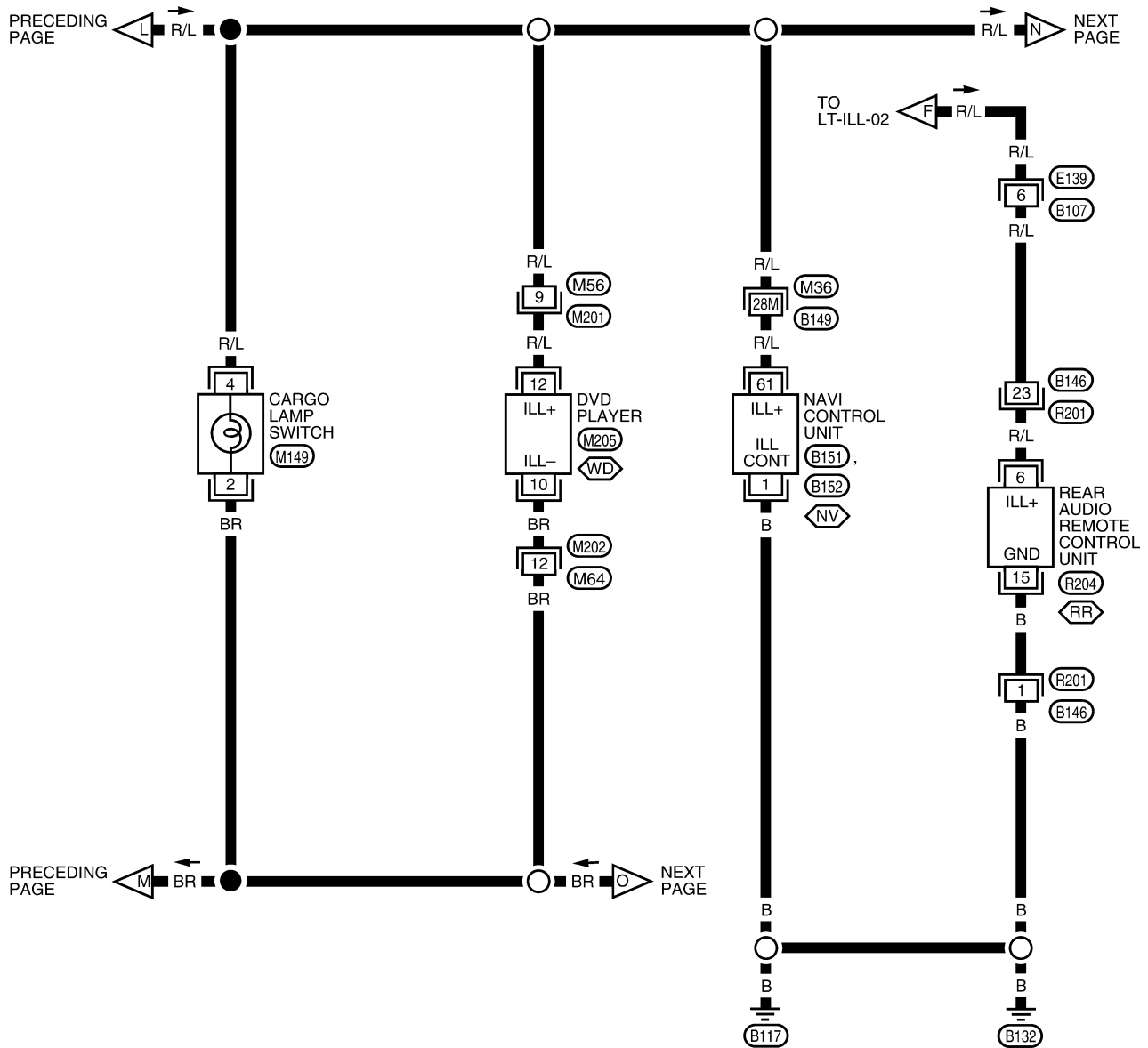

REFER TO THE FOLLOWING.  
 - SUPER MULTIPLE JUNCTION (SMJ)

WKWA3792E

# ILLUMINATION

LT-ILL-07

TT : TRAILER TOW 7 PIN  
PW : WITH POWER WINDOWS

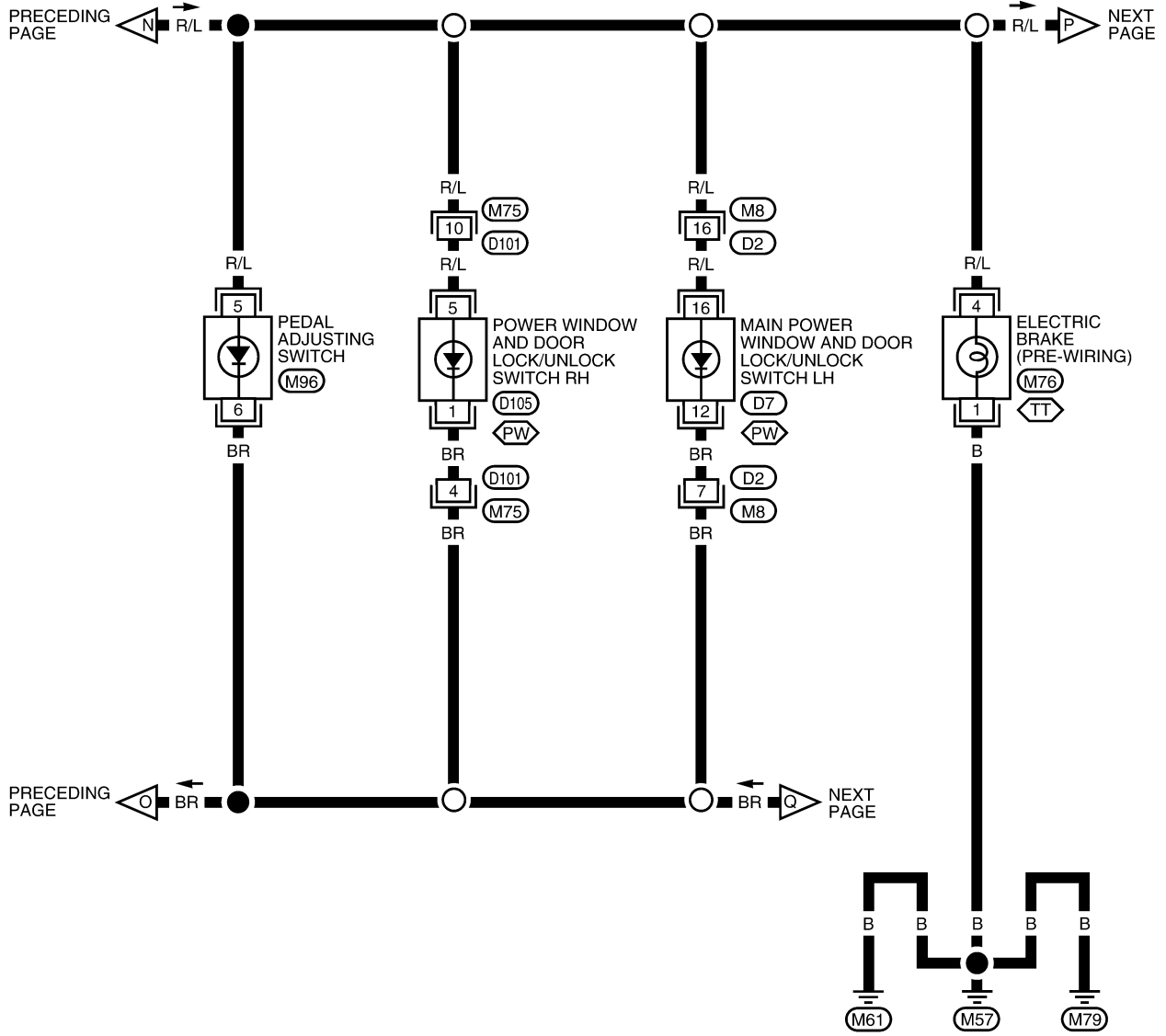

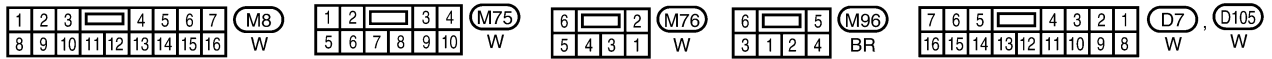

A  
B  
C  
D  
E  
F  
G  
H  
I  
J  
LT  
L  
M



WKWA5158E

# ILLUMINATION

LT-ILL-08

-  : WITH REAR POWER DROP GLASS
-  : WITH HEATED SEATS
-  : FLOOR SHIFT

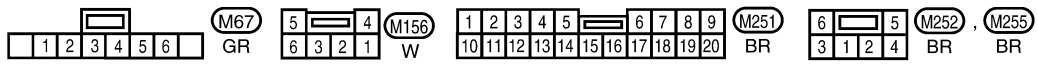
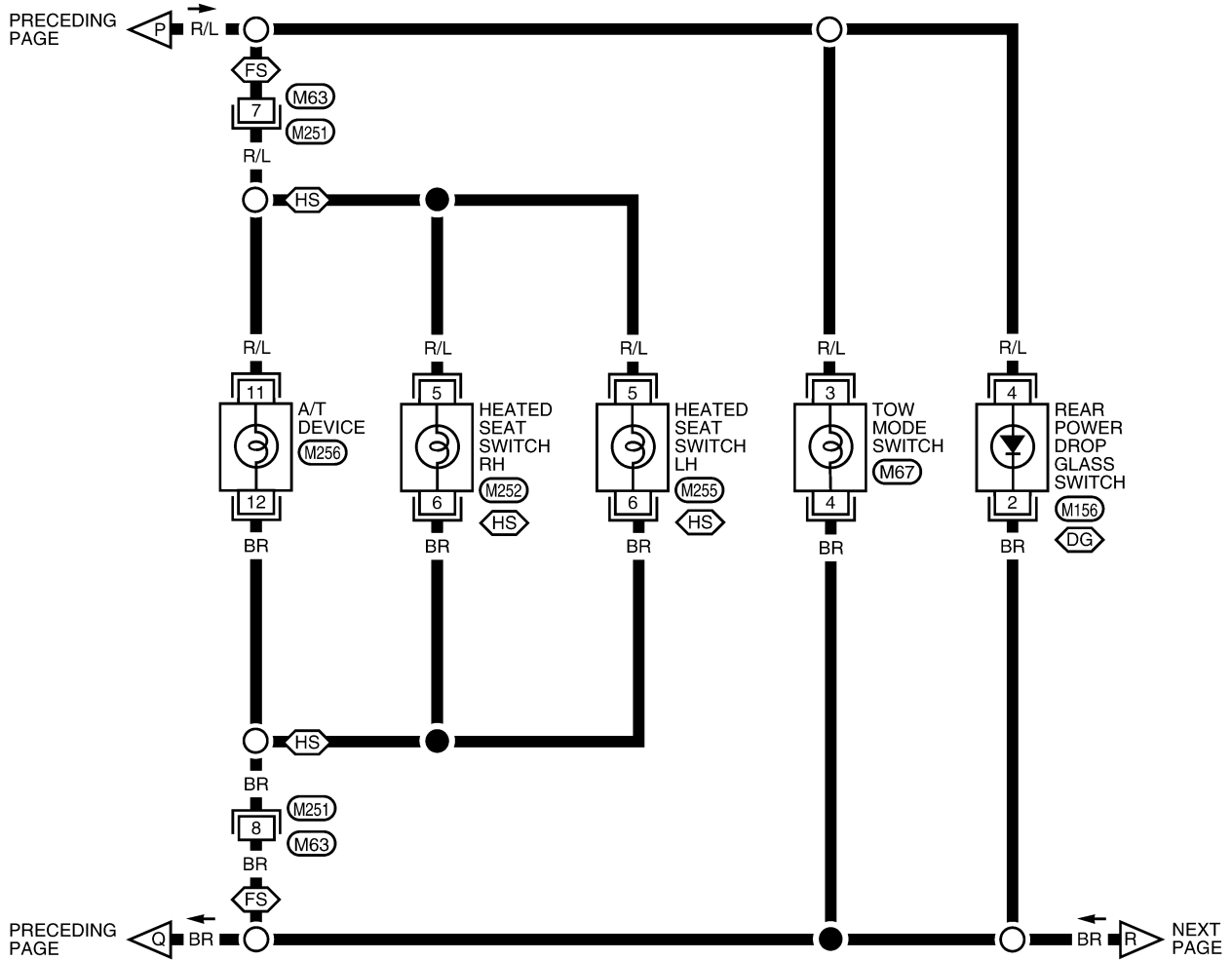

WKWA3794E

# ILLUMINATION

LT-ILL-09

— : DATA LINE

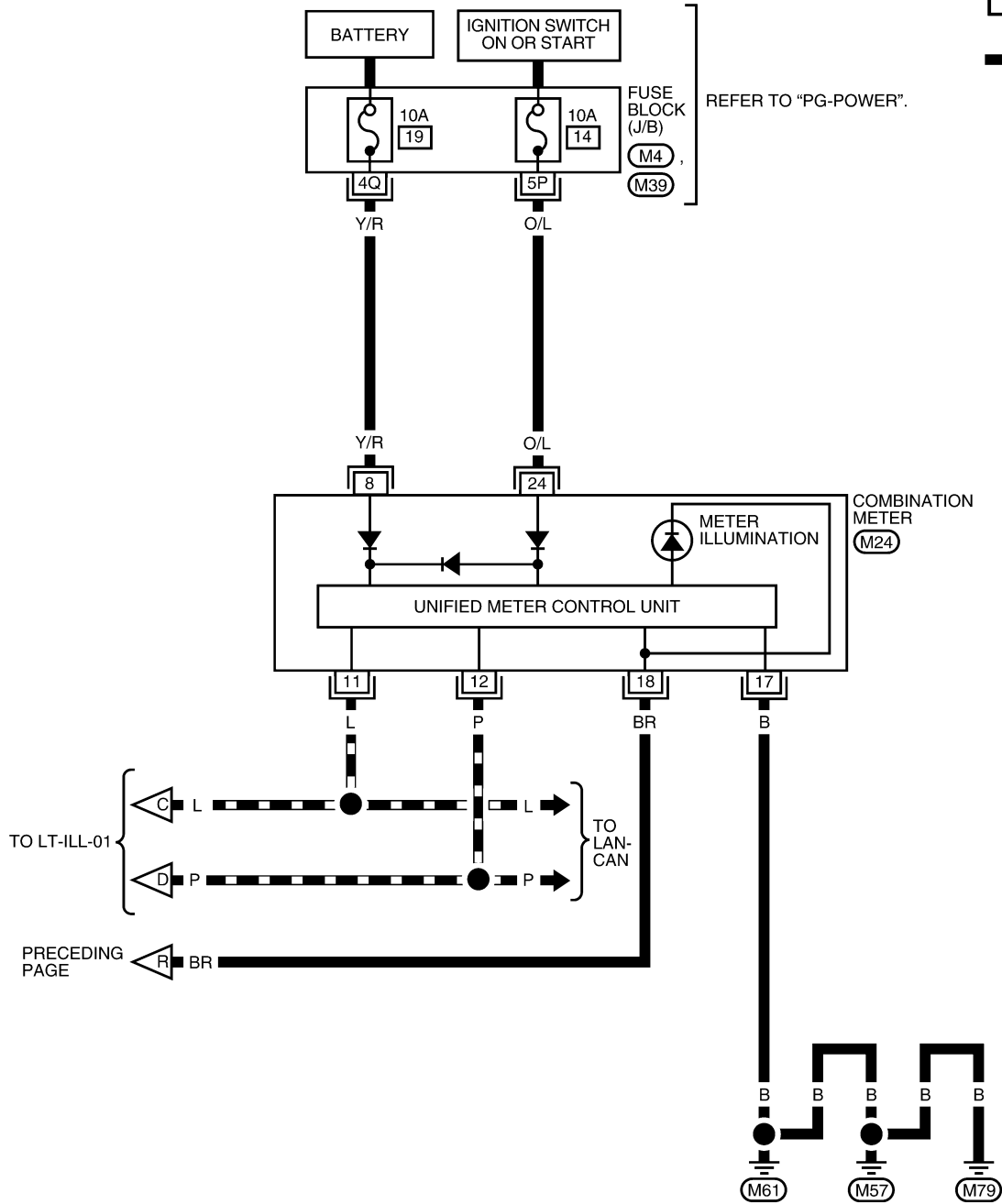

A  
B  
C  
D  
E  
F  
G  
H  
I  
J  
LT  
L  
M

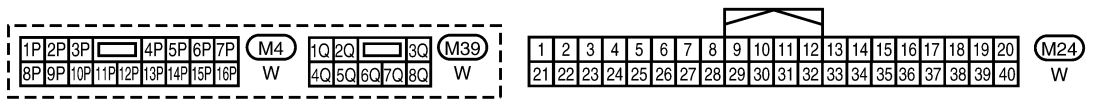

WKWA3795E

# ILLUMINATION

## Removal and Installation ILLUMINATION CONTROL SWITCH

EKS00ACK

### Removal

1. Remove cluster lid A. Refer to [JP-13, "COMBINATION METER"](#).
2. Carefully pry tabs and remove illumination control switch from cluster lid A.

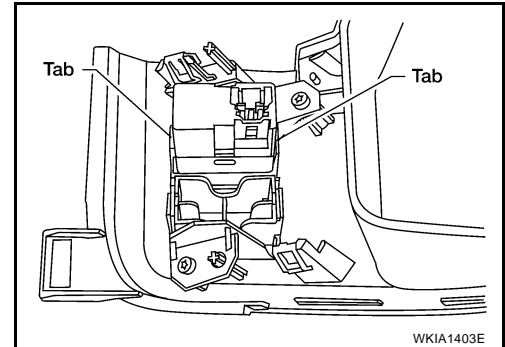

### Installation

Installation is in the reverse order of removal.



# BULB SPECIFICATIONS

## BULB SPECIFICATIONS

PF:26297

### Headlamp

EKS00ACL

Item	Wattage (W)*
Low	51 (HB4)
High	60 (HB3)

\*: Always check with the Parts Department for the latest parts information.

### Exterior Lamp

EKS00ACM

Item	Wattage (W)*	
Front combination lamp	Turn signal/parking lamp (front)	27/8
	Side marker (front)	3.8
Rear combination lamp	Stop/tail lamp	27/7
	Turn signal lamp	27
	Back-up lamp	18
	Cargo lamp (tailgate)	16
Fog lamp	37.5	
License plate lamp	5	
High-mounted stop lamp	*	
Cargo lamp (in high-mounted stop lamp)	16	
Puddle lamp	8	

\*: Always check with the Parts Department for the latest parts information.

### Interior Lamp/Illumination

EKS00ACN

Item	Wattage (W)*
Glove box lamp	3.4
Room/Map lamp	8
A/T device lamp	3
Foot lamp	3.4
Step lamp	3.8
Vanity lamp	1.32
Personal lamp	5

\*: Always check with the Parts Department for the latest parts information.

# BULB SPECIFICATIONS

---