

A
B
C
D
E
F
G
H
I
J
L
M

DI

SECTION

DRIVER INFORMATION SYSTEM

CONTENTS

PRECAUTION	3	Water Temperature Signal Inspection	18
Precautions for Supplemental Restraint System (SRS) "AIR BAG" and "SEAT BELT PRE-TENSIONER"	3	Engine Speed Signal Inspection	18
PREPARATION	4	Engine Oil Pressure Signal Inspection	19
Commercial Service Tool	4	Fuel Level Sensor Unit Inspection	20
COMBINATION METERS	5	FUEL LEVEL SENSOR UNIT	20
Component Parts and Harness Connector Location	5	LOW-FUEL WARNING LAMP	20
System Description	5	Fuel Gauge Fluctuates, Indicates Wrong Value, or Varies	21
UNIFIED METER CONTROL UNIT	5	Fuel Gauge Does Not Move to Full-position	21
POWER SUPPLY AND GROUND CIRCUIT	6	Electrical Components Inspection	22
WATER TEMPERATURE GAUGE	6	FUEL LEVEL SENSOR UNIT CHECK	22
ENGINE OIL PRESSURE GAUGE	6	OIL PRESSURE SWITCH CHECK	22
A/T OIL TEMPERATURE GAUGE (IF EQUIPPED)	6	Removal and Installation of Combination Meter	22
VOLTAGE GAUGE	6	COMPASS AND THERMOMETER	23
TACHOMETER	6	System Description	23
FUEL GAUGE	6	OUTSIDE TEMPERATURE DISPLAY	23
SPEEDOMETER	6	DIRECTION DISPLAY	23
ODO/TRIP METER	6	Wiring Diagram — COMPAS —	24
CAN COMMUNICATION SYSTEM DESCRIPTION	6	Trouble Diagnoses	25
Arrangement of Combination Meter	7	PRELIMINARY CHECK FOR THERMOMETER..	25
Internal Circuit	8	INSPECTION/COMPASS AND THERMOMETER	25
Wiring Diagram — METER —	9	Calibration Procedure for Compass	26
Combination Meter Harness Connector Terminal		CORRECTION FUNCTIONS OF COMPASS	26
Layout	11	INITIAL CORRECTION PROCEDURE FOR COMPASS	26
Terminals and Reference Values for Combination Meter	11	WARNING LAMPS	27
Self-Diagnosis Mode of Combination Meter	12	Schematic	27
SELF-DIAGNOSIS FUNCTION	12	Wiring Diagram — WARN —	28
HOW TO INITIATE COMBINATION METER SELF-DIAGNOSIS MODE	12	Oil Pressure Warning Lamp Stays Off (Ignition Switch ON)	34
COMBINATION METER SELF-DIAGNOSIS MODE FUNCTIONS	12	Oil Pressure Warning Lamp Does Not Turn Off (Oil Pressure Is Normal)	34
How to Proceed With Trouble Diagnosis	16	A/T INDICATOR	35
Preliminary Check	16	Wiring Diagram — AT/IND —	35
Symptom Chart	17	A/T Indicator Does Not Illuminate	36
Power Supply and Ground Circuit Inspection	17	WARNING CHIME	37
Vehicle Speed Signal Inspection	18	Component Parts and Harness Connector Location..	37
		System Description	38
		FUNCTION	38

IGNITION KEY WARNING CHIME	38	REAR SONAR SYSTEM OFF SWITCH	51
LIGHT WARNING CHIME	38	SONAR BUZZER	51
SEAT BELT WARNING CHIME	39	REAR SONAR SENSOR	52
CAN Communication System Description	39	Wiring Diagram — SONAR —	53
Wiring Diagram — CHIME —	40	Sonar Control Unit Harness Connector Terminal Layout	55
Terminals and Reference Values for BCM	42	Terminals and Reference Values for Sonar Control Unit	55
Terminals and Reference Values for Combination Meter	42	How to Proceed With Trouble Diagnosis	56
How to Proceed With Trouble Diagnosis	42	Pre-diagnosis Inspection	56
Preliminary Check	42	SENSOR STATUS CHECK	56
INSPECTION FOR POWER SUPPLY AND GROUND CIRCUIT	42	Self-diagnosis Function	56
CONSULT-II Function (BCM)	43	ENTERING DIAGNOSTICS MODE	56
CONSULT-II START PROCEDURE	43	REQUESTING NUMBER OF FAULT CODES MODE	57
DATA MONITOR	43	REQUESTING FAULT CODES MODE	57
ACTIVE TEST	43	IDLING OR CLEARING FAULT CODES MODE...	57
SELF-DIAGNOSTIC RESULTS	43	Preliminary Check	58
All Warning Chimes Do Not Operate	44	INSPECTION FOR POWER SUPPLY AND GROUND CIRCUIT	58
Key Warning Chime and Light Warning Chime Do Not Operate (Seat Belt Warning Chime Does Oper- ate)	44	Symptom Chart	59
Key Warning Chime Does Not Operate	45	Component Inspection	60
Light Warning Chime Does Not Operate	47	SONAR BUZZER	60
Seat Belt Warning Chime Does Not Operate	48	REAR SONAR SYSTEM OFF SWITCH	60
REAR SONAR SYSTEM	50	REAR SONAR SYSTEM OFF INDICATOR	61
Component Parts and Harness Connector Location..	50	Removal and Installation	61
System Description	51	REAR SONAR SENSORS	61
FUNCTION	51	SONAR CONTROL UNIT	61

PRECAUTION

PRECAUTION

PFP:00011

Precautions for Supplemental Restraint System (SRS) “AIR BAG” and “SEAT BELT PRE-TENSIONER”

EKS00ACO

The Supplemental Restraint System such as “AIR BAG” and “SEAT BELT PRE-TENSIONER”, used along with a front seat belt, helps to reduce the risk or severity of injury to the driver and front passenger for certain types of collision. This system includes seat belt switch inputs and dual stage front air bag modules. The SRS system uses the seat belt switches to determine the front air bag deployment, and may only deploy one front air bag, depending on the severity of a collision and whether the front occupants are belted or unbelted. Information necessary to service the system safely is included in the SRS and SB section of this Service Manual.

WARNING:

- To avoid rendering the SRS inoperative, which could increase the risk of personal injury or death in the event of a collision which would result in air bag inflation, all maintenance must be performed by an authorized NISSAN/INFINITI dealer.
- Improper maintenance, including incorrect removal and installation of the SRS, can lead to personal injury caused by unintentional activation of the system. For removal of Spiral Cable and Air Bag Module, see the SRS section.
- Do not use electrical test equipment on any circuit related to the SRS unless instructed to in this Service Manual. SRS wiring harnesses can be identified by yellow and/or orange harnesses or harness connectors.

A

B

C

D

E

F

G

H

I

J

DI

L

M

PREPARATION

PREPARATION

PF0:00002

Commercial Service Tool

EKS00ACQ

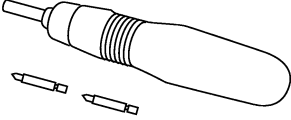
Tool name	Description
<p data-bbox="162 296 272 323">Power tool</p>  <p data-bbox="852 499 922 514">PBIC0191E</p>	<p data-bbox="1015 296 1274 323">Loosening bolts and nuts.</p>

COMBINATION METERS

Component Parts and Harness Connector Location

EKS00ACT

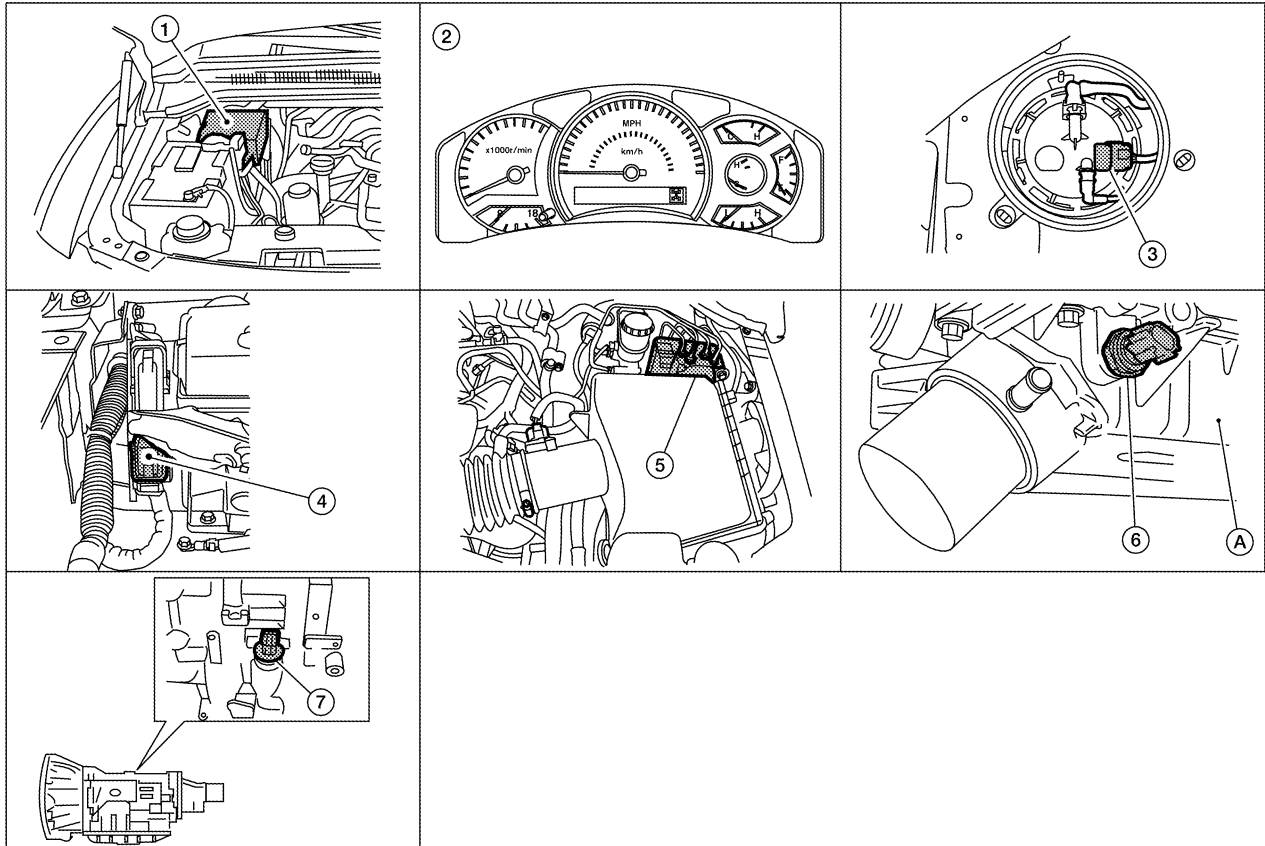

- | | | |
|--|---|--|
| 1. IPDM E/R E122 | 2. Combination meter M24 | 3. Fuel level sensor unit and fuel pump C5 (view with fuel tank removed) |
| 4. ECM E16 (view with battery removed) | 5. ABS actuator and electric unit (control unit) E125 | 6. Oil pressure switch F4
A. Oil pan (upper) |
| 7. A/T assembly F9 | | |

WKIA5605E

System Description UNIFIED METER CONTROL UNIT

EKS00ACR

- Speedometer, odometer, tachometer, fuel gauge, oil pressure gauge, voltage gauge, A/T oil temperature gauge (if equipped), and water temperature gauge are controlled by the unified meter control unit, which is built into the combination meter.
- Warning indicators are controlled by signals drawn from the CAN communication system, and components connected directly to the combination meter.
- Digital meter is adopted for odometer/trip meters*, as well as the A/T position indicator display.
*The record of the odometer is kept even if the battery cable is disconnected.
- Odometer/trip meters and A/T indicator segments can be checked in diagnosis mode.
- Meters/gauges can be checked in diagnosis mode.

Illumination control

The unified meter control unit outputs the speedometer, odometer/trip meters, tachometer, engine oil pressure gauge, voltage gauge, A/T indicator, A/T oil temperature gauge (if equipped), fuel and temperature gauge lighting when the ignition switch is turned on. When the headlamp (combination) switch is turned on, the illumination control switch can be used to adjust the brightness of the combination meter illumination and the odometer/trip meters and meter illumination. When the ignition switch is turned from the OFF to the ON position, the combination meter dial lighting will remain off for 0.7 seconds. For additional combination meter illumination control information, refer to [LT-129, "System Description"](#).

COMBINATION METERS

POWER SUPPLY AND GROUND CIRCUIT

Power is supplied at all times

- through 10A fuse [No.19, located in the fuse block (J/B)]
- to combination meter terminal 8.

With the ignition switch in the ON or START position, power is supplied

- through 10A fuse [No.14, located in the fuse block (J/B)]
- to combination meter terminal 24.

Ground is supplied

- to combination meter terminal 17
- through body grounds M57, M61 and M79.

WATER TEMPERATURE GAUGE

The water temperature gauge indicates the engine coolant temperature.

ECM provides an engine coolant temperature signal to combination meter via CAN communication lines.

ENGINE OIL PRESSURE GAUGE

The engine oil pressure gauge indicates whether the engine oil pressure is low or normal.

The oil pressure gauge is controlled by the IPDM E/R (intelligent power distribution module engine room). Low oil pressure causes oil pressure switch terminal 1 to provide ground to IPDM E/R terminal 42. The IPDM E/R then signals the combination meter (unified meter control unit) via CAN communication lines and a low oil pressure indication is displayed by the oil pressure gauge.

A/T OIL TEMPERATURE GAUGE (IF EQUIPPED)

The A/T oil temperature gauge indicates the A/T fluid temperature.

TCM provides a A/T oil temperature signal to combination meter via CAN communication lines.

VOLTAGE GAUGE

The voltage gauge indicates the battery/charging system voltage.

The voltage gauge is regulated by the unified meter control unit.

TACHOMETER

The tachometer indicates engine speed in revolutions per minute (rpm).

ECM provides an engine speed signal to combination meter via CAN communication lines.

FUEL GAUGE

The fuel gauge indicates the approximate fuel level in the fuel tank.

The fuel gauge is regulated by the unified meter control unit and a variable resistor signal supplied

- to combination meter terminal 15
- through fuel level sensor unit and fuel pump terminal 2
- through fuel level sensor unit and fuel pump terminal 5
- from combination meter terminal 16.

SPEEDOMETER

ABS actuator and electric unit (control unit) provides a vehicle speed signal to the combination meter via CAN communication lines.

ODO/TRIP METER

The vehicle speed signal and the memory signals from the meter memory circuit are processed by the combination meter and the mileage is displayed.

How to Change the Display

Refer to Owner's Manual for odo/trip meter operating instructions.

CAN COMMUNICATION SYSTEM DESCRIPTION

Refer to [LAN-2, "SYSTEM DESCRIPTION"](#) .

COMBINATION METERS

Arrangement of Combination Meter

EKS00ACU

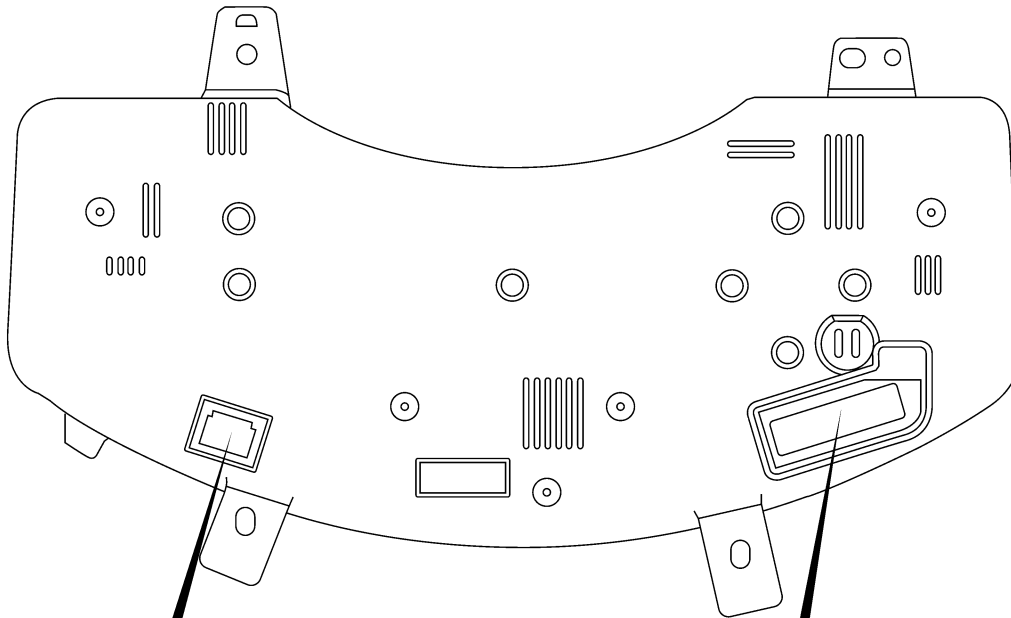
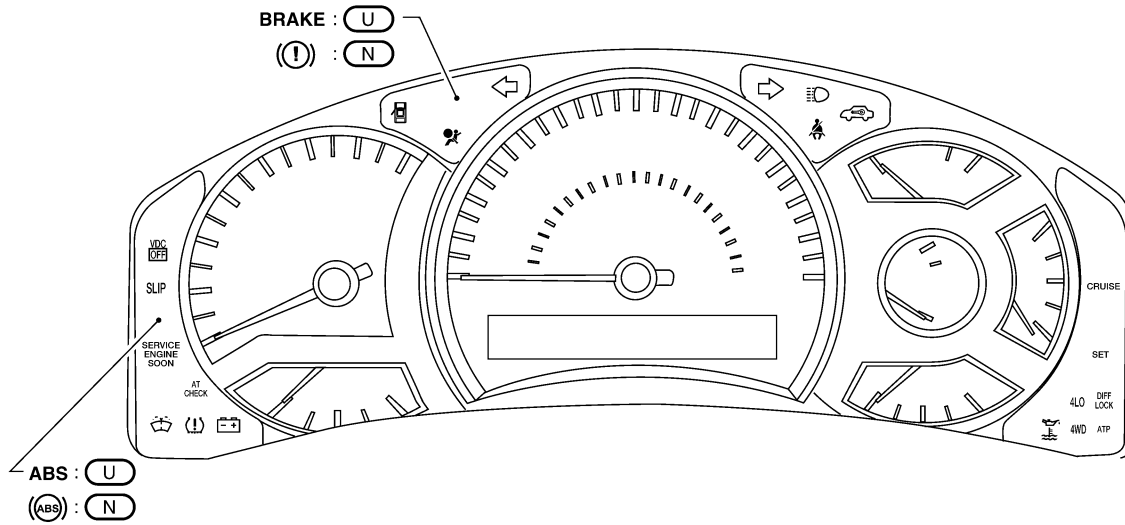

N : CANADA
U : USA

46	45	44	43	42	41
52	51	50	49	48	47

M25

20	19	18	17	16	15	14	13	12	11	10	9	8	7	6	5	4	3	2	1
40	39	38	37	36	35	34	33	32	31	30	29	28	27	26	25	24	23	22	21

M24

WKIA5726E

COMBINATION METERS

Internal Circuit

EKS00ACV

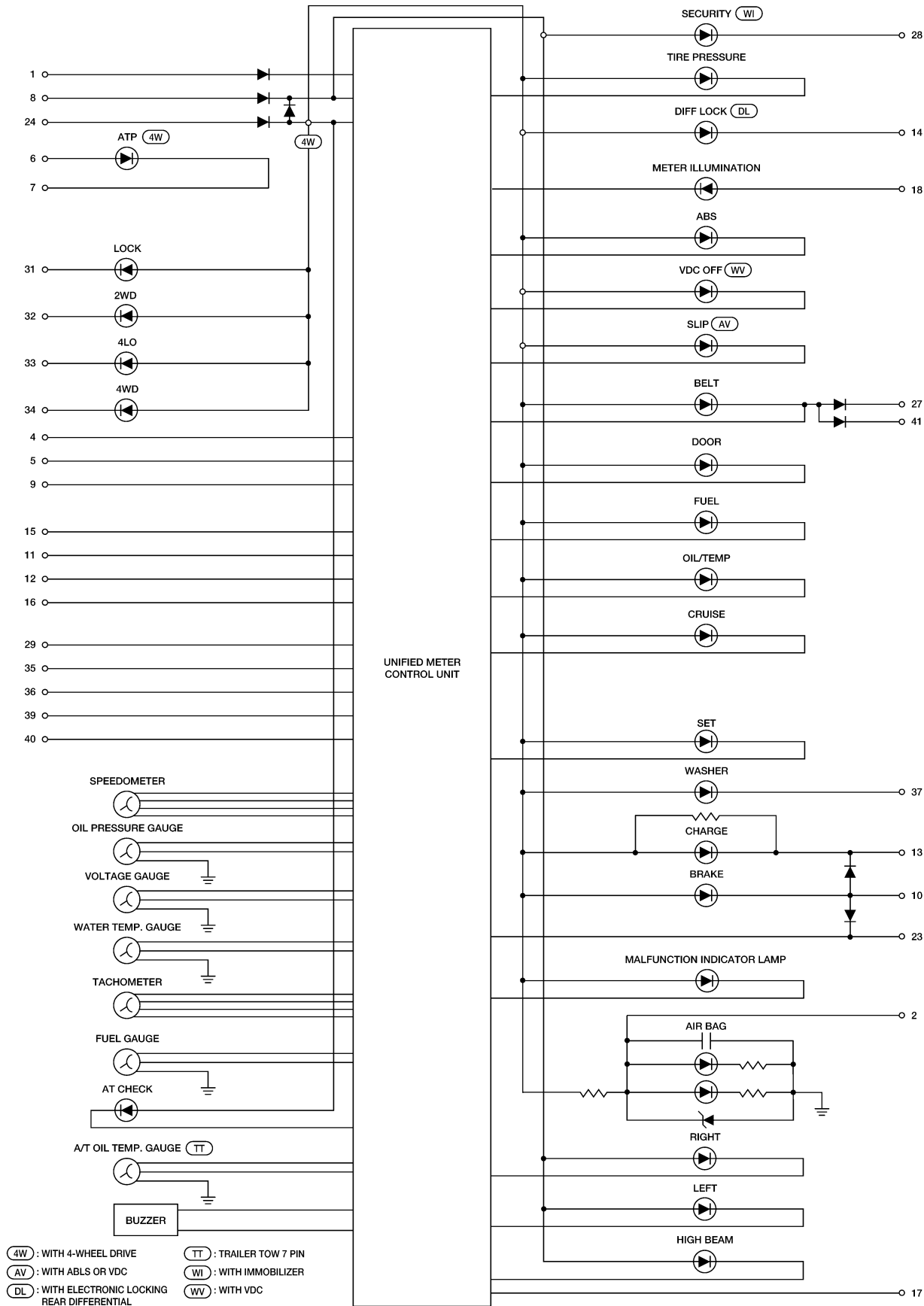

WKWA5160E

COMBINATION METERS

Wiring Diagram — METER —

EKS00ACW

DI-METER-01

— : DATA LINE
 : TRAILER TOW 7 PIN

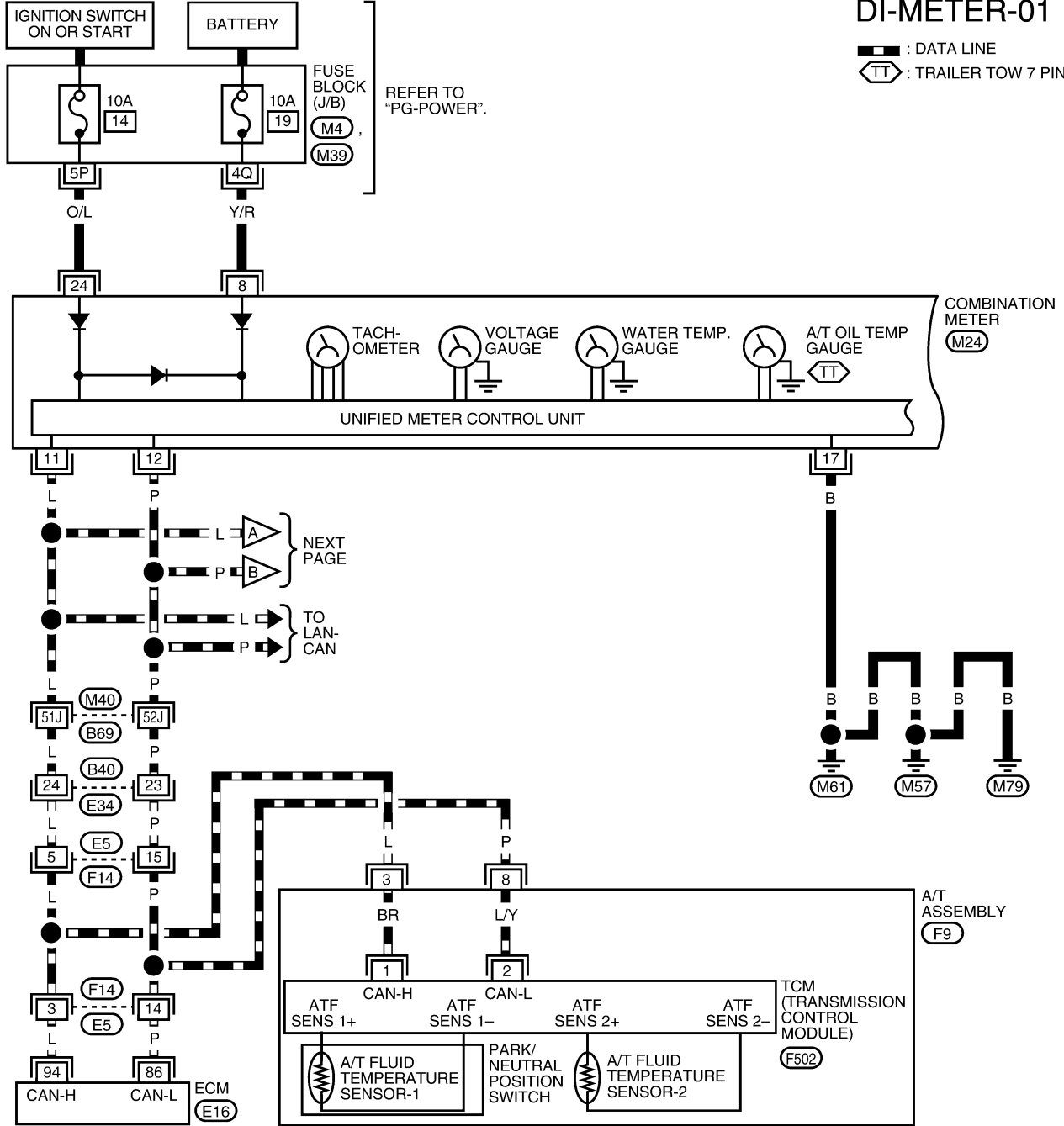

A
B
C
D
E
F
G
H
I
J
DI
L
M

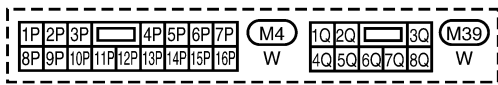

REFER TO THE FOLLOWING.
 (E16) - ELECTRICAL UNITS
 (M40) - SUPER MULTIPLE JUNCTION (SMJ)

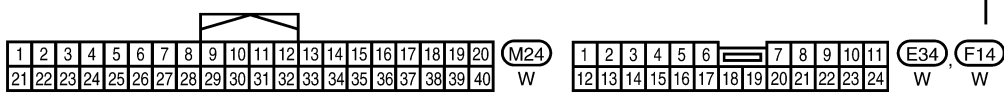

*: THIS CONNECTOR IS NOT SHOWN IN "HARNESS LAYOUT" OF PG SECTION.

WKWA5161E

COMBINATION METERS

DI-METER-02

▬ : DATA LINE

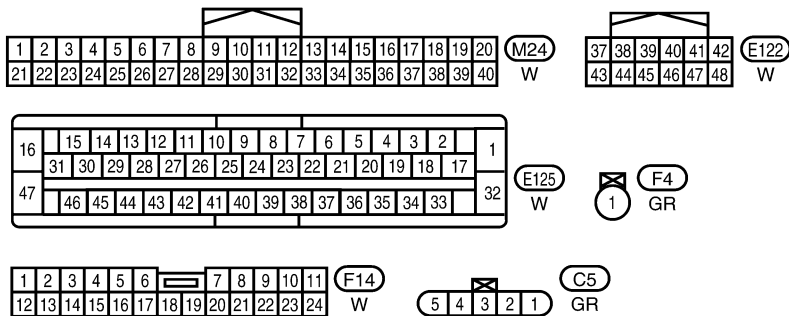
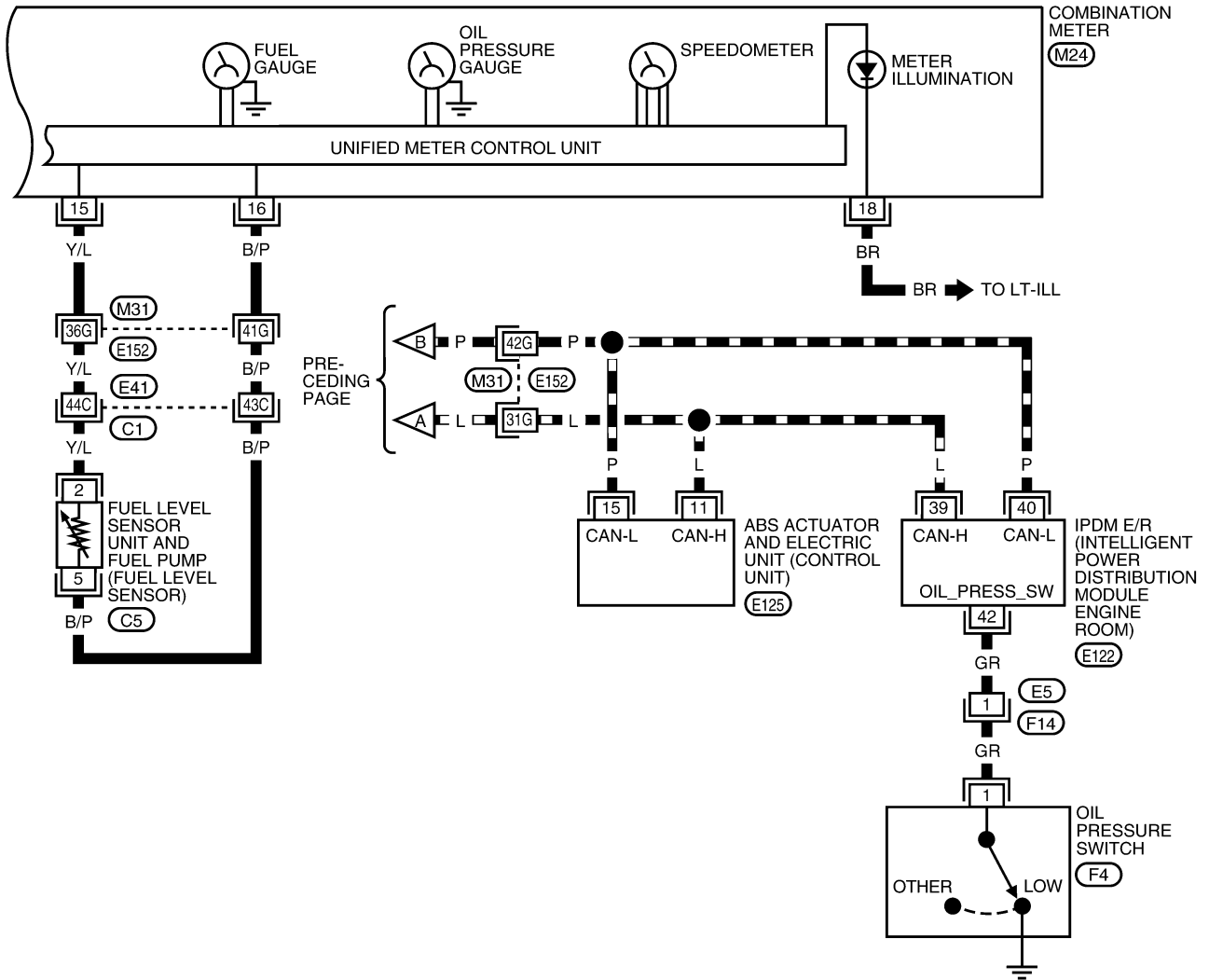

REFER TO THE FOLLOWING.
 (M31), (C1) - SUPER
 MULTIPLE JUNCTION (SMJ)

WKWA5162E

COMBINATION METERS

Combination Meter Harness Connector Terminal Layout

EKS00IZV

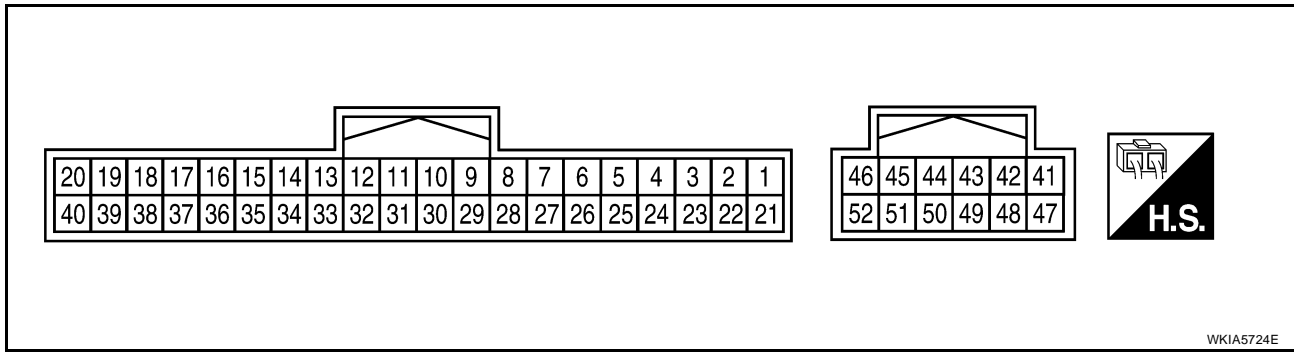

Terminals and Reference Values for Combination Meter

EKS00ACX

Terminal No.	Wire color	Item	Condition		Reference value (V) (Approx.)
			Ignition switch	Operation or condition	
1	O	Ignition switch ACC or ON	ON	—	Battery voltage
8	Y/R	Battery power supply	OFF	—	Battery voltage
9	R/G	Stop lamp switch	ON	Brake pedal depressed	Battery voltage
				Brake pedal released	0
10	P/B	Brake fluid level switch	ON	Brake fluid level low	0
				Brake fluid level normal	Battery voltage
11	L	CAN-H	—	—	—
12	P	CAN-L	—	—	—
14	L	DIFF LOCK indicator input	OFF	DIFF LOCK indicator ON	0
				DIFF LOCK indicator OFF	Battery voltage
15	Y/L	Fuel level sensor signal	—	—	Refer to DI-20, "Fuel Level Sensor Unit Inspection" .
16	B/P	Fuel level sensor and oil pressure sensor ground	ON	—	0V
17	B	Ground	—	—	0V
18	BR	Illumination control switch	—	Lighting switch ON	Refer to LT-130, "ILLUMINATION OPERATION BY LIGHTING SWITCH" .
23	G	Parking Brake switch	ON	Parking brake applied	0
				Parking brake released	Battery voltage
24	O/L	Ignition switch ON or START	ON	—	Battery voltage
27	O/B	Seat belt buckle switch LH	ON	Unfastened (ON)	0
				Fastened (OFF)	Battery voltage
28	G/O	Security indicator input	OFF	Security indicator ON	0
				Security indicator OFF	Battery voltage
29	W/R	Vehicle speed signal (8-pulse)	ON	Speedometer operated [When vehicle speed is approx. 40 km/h (25 MPH)]	

PKIA1935E

COMBINATION METERS

Terminal No.	Wire color	Item	Condition		Reference value (V) (Approx.)
			Ignition switch	Operation or condition	
37	W/L	Washer fluid level switch	ON	Washer fluid level low	0
				Washer fluid level normal	Battery voltage
41	P/L	Seat belt buckle switch RH	ON	Unfastened (ON)	0
				Fastened (OFF)	Battery voltage

Self-Diagnosis Mode of Combination Meter SELF-DIAGNOSIS FUNCTION

EKS00AC Y

The following items can be checked during Combination Meter Self-Diagnosis Mode.

- Gauge sweep and present gauge values.
- Illuminates all odometer, fuel, and engine temperature segments.
- Illuminates all micro controlled lamps/LEDs regardless of switch configuration.
- Displays estimated present battery voltage.
- Displays seat belt buckle switch LH status.

HOW TO INITIATE COMBINATION METER SELF- DIAGNOSIS MODE

NOTE:

Once entered, Combination Meter Self-Diagnosis Mode will function with the ignition switch in ON or START. Combination Meter Self-Diagnosis Mode will exit upon turning the ignition switch to OFF or ACC. To initiate Combination Meter Self-Diagnosis Mode, refer to the following procedure.

1. Turn the ignition switch ON, while holding the odometer/trip meter switch for 5 - 8 seconds. When the diagnosis function is activated the odometer/trip meter will display tESt.

NOTE:

Check combination meter power supply and ground circuit when self-diagnosis mode of combination meter does not start. Refer to [DI-17, "Power Supply and Ground Circuit Inspection"](#) . Replace combination meter if normal. Refer to [IP-13, "COMBINATION METER"](#) .

COMBINATION METER SELF-DIAGNOSIS MODE FUNCTIONS

To interpret Combination Meter Self-Diagnosis Mode functions, refer to the following table.

Event	Odometer Display	Description of Test/Data	Notes:
Odometer/trip meter A/B switch held from 5 to 8 seconds (or until released)	tESt		Initiating self-diagnosis mode
Odometer/trip meter A/B switch engaged and released = next test requested	rXXXX, FAIL	Return to normal operation of all lamps/LEDs and displays hex ROM rev. If a ROM checksum fault exists, display alternates between "r XXXX" and "FAIL".	
Next test requested	nrXXXX	Displays hex ROM rev as stored in NVM.	
Next test requested	Sc1XX	Displays 8-bit software configuration value in Hex format.	Bit Coding 7-3 = reserved for future use 2 = TCS/VDC 0 = not present 1 = present 1 = Shift type 0 = Column shift 1 = Floor shift 0 = ICC 0 = not present 1 = present
Next test requested	Sc2XX	Displays 8-bit software configuration value in Hex format.	Bit coding 7-0 = Reserved for future use

COMBINATION METERS

Event	Odometer Display	Description of Test/Data	Notes:	
Next test requested	EprXX	Displays 8-bit software configuration value in Hex format.	Bit Coding 7-2 = reserved for future use 1 = A/T Oil Temp (gauge) 0 = not present 1 = present 1 = Odo Units 0 = kilometers 1 = miles	A
Next test requested	1nFXX	Displays 8-bit market info value in Hex format.	\$31 = USA \$2A = Canada	B
Next test requested	cYLXX	Displays 8-bit engine configuration value in Hex format.	\$08 = 8 cylinder \$06 = 6 cylinder	C
Next test requested	bulb	Illuminates all micro-controlled lamps/LEDs regardless of SW configuration.		D
Next test requested	D-HI	Meter/LCD Illumination.		E
Next test requested	(All segments illuminated)	Lights all odometer/trip meter, fuel, and engine temperature display segments.	Full daytime brightness all LCD segments active	F
Next test requested	N-HI	Meter/LCD Illumination.		G
Next test requested	(All segments illuminated)	Lights all odometer/trip meter, fuel, and engine temperature display segments.	Full nighttime brightness all LCD segments active	H
Next test requested	N-LO	Meter/LCD Illumination.		I
Next test requested	(All segments illuminated)	Lights all odometer/trip meter, fuel, and engine temperature display segments.	Min. nighttime brightness all LCD segments active	J
Next test requested	dS XX	Current dimming step.	1-21	
Next test requested	EE XX, FAIL	Hex EE level. If EE checksum fault exists, display alternates between "EE XX" and "FAIL".		DI
Next test requested	dtXXXX	Hex coding of final manufacturing test date.		L
Next test requested	GAGE	Performs sweep of all gauges, then displays present gauge values. Performs checksum tests on ROM and EE.	Gauges sweep within 10 seconds	M
Next test requested	FFXXXX	Displays 16-bit fuel flow constant "Q" in tenths of cc/min in Hex format.	\$0000 - \$FFFF	
Next test requested	tF	Displays 16-bit tire factor "A" in hundredths in Hex format.	\$0000 - \$FFFF	
Next test requested	oP	Current oil pressure value in A/D counts in hex format.	\$00 - \$FF	
Next test requested	ot1XX	Displays oil pressure tell-tale "on" threshold in A/D counts in Hex format.	\$00 - \$FF	

COMBINATION METERS

Event	Odometer Display	Description of Test/Data	Notes:
Next test requested	ot0XX	Displays oil pressure tell-tale "off" threshold in A/D counts in Hex format.	\$00 - \$FF
Next test requested	XXXXX	Raw uncompensated english speed value in hundredths of MPH. Speedometer indicates present speed.	Will display "-----" if message is not received. Will display "99999" if data received is invalid
Next test requested	XXXXX	Raw uncompensated metric speed value in hundredths of KPH. Speedometer indicates present speed.	Will display "-----" if message is not received. Will display "99999" if data received is invalid
Next test requested	tXXXX	Tachometer value in RPM. Tachometer indicates present RPM.	Will display "-----" if message is not received.
Next test requested	F1 XXXX	Present ratioed fuel level A/D input 1 in decimal format. Fuel gauge indicates present filtered level.	000-009 = Short circuit 010-254 = Normal range 255 = Open circuit --- = Missing 5 seconds
Next test requested	F2 XXX	Present FLPS.	010-254 normal range
Next test requested	FS X	Fuel filter rate	0 = Normal 1 = Fast
Next test requested	XXXX	Last temperature gauge input value in degrees C. Temperature gauge indicates present filtered temperature.	Will display "---"C if message is not received. Will display "999" if data received is invalid.
Next test requested	BAtXX.X	Estimated present battery voltage.	
Next test requested	rES -X	Seat belt buckle switch LH status.	0 = Unbuckled 1 = Buckled
Next test requested	PA -XX	Hex value port A.	
Next test requested	Pb -XX	Hex value port B.	
Next test requested	PE -XX	Hex value port E.	
Next test requested	PL -XX	Hex value port L.	
Next test requested	P6 -XX	Hex value port K.	
Next test requested	Pn -XX	Hex value port M.	
Next test requested	PP -XX	Hex value port P.	
Next test requested	PS -XX	Hex value port S.	
Next test requested	Pt -XX	Hex value port T.	
Next test requested	Pu -XX	Hex value port U.	
Next test requested	P4 -XX	Hex value port V.	
Next test requested	Puu -XX	Hex value port W.	
Next test requested	A00XXX	A/D port A/D value (non-ratioed).	0-255
Next test requested	A01XXX	A/D port A/D value (non-ratioed).	0-255
Next test requested	A02XXX	A/D port A/D value (non-ratioed).	0-255
Next test requested	A03XXX	A/D port A/D value (non-ratioed).	0-255

COMBINATION METERS

Event	Odometer Display	Description of Test/Data	Notes:
Next test requested	A04XXX	A/D port A/D value (non-ratioed).	0-255
Next test requested	A05XXX	A/D port A/D value (non-ratioed).	0-255
Next test requested	A06XXX	A/D port A/D value (non-ratioed).	0-255
Next test requested	A07XXX	A/D port A/D value (non-ratioed).	0-255
Next test requested	A08XXX	A/D port A/D value (non-ratioed).	0-255
Next test requested	A09XXX	A/D port A/D value (non-ratioed).	0-255
Next test requested	A10XXX	A/D port A/D value (non-ratioed).	0-255
Next test requested	A11XXX	A/D port A/D value (non-ratioed).	0-255
Next test requested	A12XXX	A/D port A/D value (non-ratioed).	0-255
Next test requested	A13XXX	A/D port A/D value (non-ratioed).	0-255
Next test requested	A14XXX	A/D port A/D value (non-ratioed).	0-255
Next test requested	A15XXX	A/D port A/D value (non-ratioed).	0-255
Next test requested	PA0-XX	Hex value representing state of A/D ports 0-7.	
Next test requested	PA1-XX	Hex value representing state of A/D ports 0-7.	
Next test requested	Thr-XXX	Decimal value of thermistor A/D reading.	0-255
Next test requested	rXXXX, FAIL		Return to beginning of self-diagnosis.

A

B

C

D

E

F

G

H

I

J

DI

L

M

COMBINATION METERS

EKS00ACZ

How to Proceed With Trouble Diagnosis

1. Confirm the symptom or customer complaint.
2. Perform preliminary check. Refer to [DI-16, "Preliminary Check"](#) .
3. According to the symptom chart, repair or replace the cause of the symptom.
4. Does the meter operate normally? If so, go to 5. If not, go to 2.
5. Inspection End.

Preliminary Check

EKS00AD0

1. CHECK WARNING INDICATOR ILLUMINATION

1. Turn ignition switch ON.
2. Make sure warning indicators (such as malfunction indicator lamp and oil pressure low/coolant temperature high warning indicator) illuminate.

Do warning indicators illuminate?

YES >> GO TO 2.

NO >> Check ignition power supply system of combination meter. Refer to [DI-17, "Power Supply and Ground Circuit Inspection"](#) .

2. CHECK OPERATION OF SELF-DIAGNOSIS MODE (COMBINATION METER)

Perform self-diagnosis mode of combination meter. Refer to [DI-12, "Self-Diagnosis Mode of Combination Meter"](#) .

Does self-diagnosis mode operate normally?

YES >> GO TO 3.

NO >> Check combination meter power supply and ground circuit. Refer to [DI-17, "Power Supply and Ground Circuit Inspection"](#) .

3. CHECK ODOMETER OPERATION

Check segment display status of odometer.

Is the display normal?

YES >> GO TO 4.

NO >> Replace the combination meter. Refer to [IP-13, "COMBINATION METER"](#) .

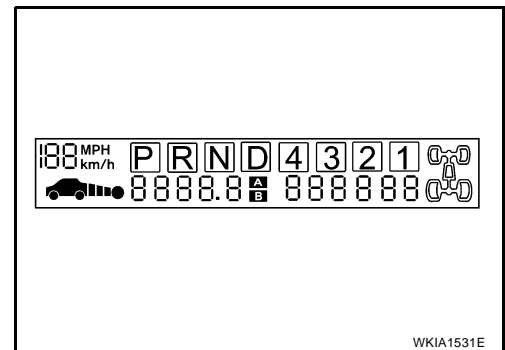

4. CHECK COMBINATION METER CIRCUIT

Check indication of each meter/gauge in self-diagnosis mode.

OK or NG

OK >> Go to [DI-17, "Symptom Chart"](#) .

NG >> Replace the combination meter. Refer to [IP-13, "COMBINATION METER"](#) .

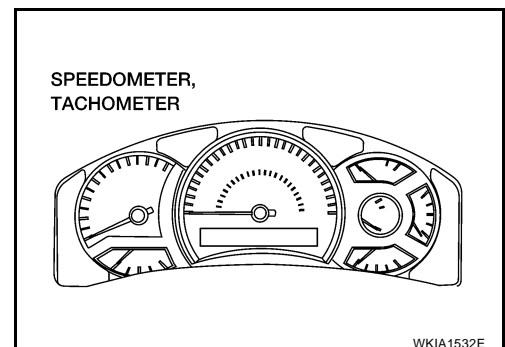

COMBINATION METERS

Symptom Chart

EKS00AD2

Trouble phenomenon	Possible cause
Improper tachometer indication.	Refer to DI-18, "Engine Speed Signal Inspection" .
Improper water temperature gauge indication.	Refer to DI-18, "Water Temperature Signal Inspection" .
Improper speedometer or odometer.	Refer to DI-18, "Vehicle Speed Signal Inspection" .
Improper engine oil pressure gauge indication.	Refer to DI-19, "Engine Oil Pressure Signal Inspection" .
Improper A/T oil temperature gauge indication.	Refer to AT-125, "DTC P1710 A/T FLUID TEMPERATURE SENSOR CIRCUIT" .
Improper voltage meter indication.	Refer to IP-13, "COMBINATION METER" .
Improper fuel gauge indication.	Refer to DI-20, "Fuel Level Sensor Unit Inspection" .
Fuel warning lamp indication is irregular.	
More than one gauge does not give proper indication.	Replace the combination meter. Refer to IP-13, "COMBINATION METER" .
Improper A/T position indication.	Refer to DI-35, "A/T INDICATOR" .
Illumination control does not operate properly.	Refer to LT-129, "ILLUMINATION" .

Power Supply and Ground Circuit Inspection

EKS00AD1

1. CHECK FUSES

Check for blown combination meter fuses.

Unit	Power source	Fuse No.
Combination meter	Battery	19
	Ignition switch ON or START	14

Refer to [DI-9, "Wiring Diagram — METER —"](#) .

OK or NG

OK >> GO TO 2.

NG >> If fuse is blown, be sure to eliminate cause of malfunction before installing new fuse. Refer to [PG-4, "POWER SUPPLY ROUTING CIRCUIT"](#) .

2. CHECK POWER SUPPLY CIRCUIT

- Disconnect combination meter connector.
- Check voltage between combination meter harness connector terminals and ground.

Terminals		(-)	Ignition switch position		
(+)			OFF	ACC	ON
Connector	Terminal	Ground	Battery voltage	Battery voltage	Battery voltage
	8		0V	0V	Battery voltage
M24	24				

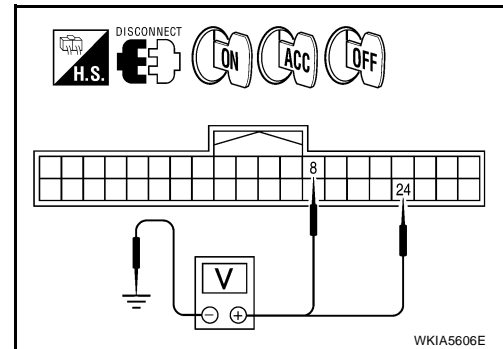

OK or NG

OK >> GO TO 3.

NG >> Check the harness for open between combination meter and fuse.

COMBINATION METERS

3. CHECK GROUND CIRCUIT

1. Turn ignition switch OFF.
2. Check continuity between combination meter harness connector terminal and ground.

Terminals		(-)	Continuity
(+)			
Connector	Terminal		
M24	17	Ground	Yes

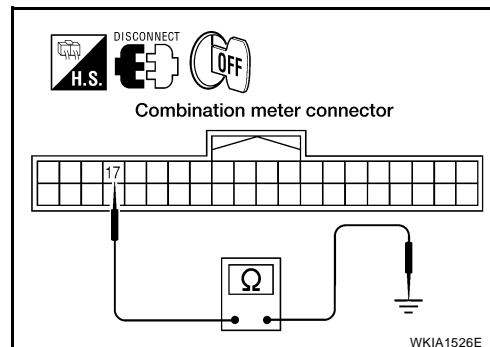

OK or NG

- OK >> Inspection End.
- NG >> Repair harness or connector.

Vehicle Speed Signal Inspection

EKS00AD3

1. CHECK ABS ACTUATOR AND ELECTRIC UNIT (CONTROL UNIT) SELF-DIAGNOSIS

Perform ABS actuator and electric unit (control unit) self-diagnosis. Refer to [BRC-22, "SELF-DIAGNOSIS"](#) .
Self-diagnostic result content

- No malfunction detected>>Replace the combination meter. Refer to [IP-13, "COMBINATION METER"](#) .
- Malfunction detected>>Perform "Diagnostic Procedure" for displayed DTC.

Water Temperature Signal Inspection

EKS00AD4

1. CHECK ECM SELF-DIAGNOSIS

Perform ECM self-diagnosis. Refer to [EC-120, "SELF-DIAG RESULTS MODE"](#) .

Self-diagnostic result content

- No malfunction detected>>Replace the combination meter. Refer to [IP-13, "COMBINATION METER"](#) .
- Malfunction detected>>Perform "Diagnostic procedure" for displayed DTC.

Engine Speed Signal Inspection

EKS00AD5

1. CHECK ECM SELF-DIAGNOSIS

Perform ECM self-diagnosis. Refer to [EC-120, "SELF-DIAG RESULTS MODE"](#) .

Self-diagnostic result content

- No malfunction detected>>Replace the combination meter. Refer to [IP-13, "COMBINATION METER"](#) .
- Malfunction detected>>Perform "Diagnostic procedure" for displayed DTC.

COMBINATION METERS

EKS00AD6

Engine Oil Pressure Signal Inspection

1. CHECK SELF-DIAGNOSTIC RESULTS OF IPDM E/R

Select "IPDM E/R" on CONSULT-II, and perform self-diagnosis of IPDM E/R. Refer to [PG-20, "SELF-DIAGNOSTIC RESULTS"](#) .

Self-diagnostic results content

No malfunction detected>>GO TO 2.

Malfunction detected>>GO TO [PG-20, "Display Item List"](#) .

2. CHECK IPDM E/R INPUT SIGNAL

Select "IPDM E/R" on CONSULT-II. Operate ignition switch with "OIL P SW" of "DATA MONITOR" and check operation status.

When ignition switch is in ON : OIL P SW CLOSE position (Engine stopped)

When engine running : OIL P SW OPEN

OK or NG

OK >> Replace combination meter. Refer to [IP-13, "COMBINATION METER"](#) .

NG >> GO TO 3.

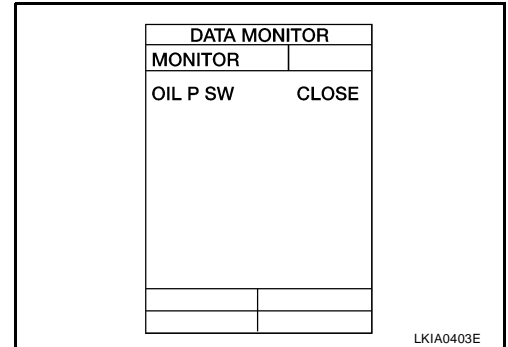

3. CHECK OIL PRESSURE SWITCH CIRCUIT

1. Turn ignition switch OFF.
2. Disconnect IPDM E/R connector E122 and oil pressure switch connector F4.
3. Check continuity between IPDM E/R harness connector E122 (A) terminal 42 and oil pressure switch harness connector F4 (B) terminal 1.

Continuity should exist.

OK or NG

OK >> GO TO 4.

NG >> Repair harness or connector.

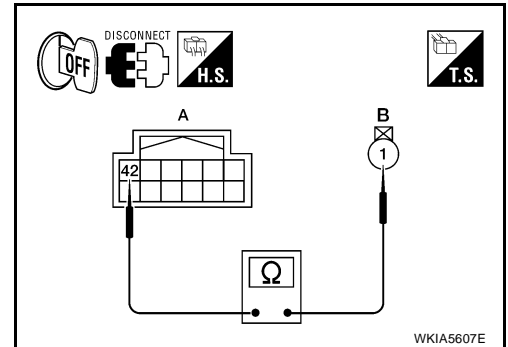

4. CHECK OIL PRESSURE SWITCH

Check oil pressure switch. Refer to [DI-22, "OIL PRESSURE SWITCH CHECK"](#) .

OK or NG

OK >> Replace IPDM E/R. Refer to [PG-30, "Removal and Installation of IPDM E/R"](#) .

NG >> Replace oil pressure switch.

COMBINATION METERS

EKS00AD7

Fuel Level Sensor Unit Inspection

FUEL LEVEL SENSOR UNIT

The following symptoms do not indicate a malfunction.

- Depending on vehicle position or driving circumstance, the fuel in the tank shifts and the indication may fluctuate.
- If the vehicle is fueled with the ignition switch ON, the indication will update slowly.
- If the vehicle is tilted when the ignition switch is turned ON, fuel in the tank may flow to one direction resulting in a change of reading.

LOW-FUEL WARNING LAMP

Depending on vehicle posture or driving circumstances, the fuel level in the tank varies, and the warning lamp ON timing may be changed.

1. CHECK HARNESS CONNECTOR

Check combination meter and fuel level sensor unit and fuel pump terminals (meter-side, and harness-side) for poor connection.

OK or NG

- OK >> GO TO 2.
- NG >> Repair or replace terminals or connectors.

2. CHECK HARNESS CONNECTOR OUTPUT SIGNAL

1. Disconnect fuel level sensor unit and fuel pump connector.
2. Turn ignition switch ON.
3. Check voltage between combination meter harness connector M24 terminal 15 and ground.

Battery voltage should exist.

OK or NG

- OK >> GO TO 3.
- NG >> Replace the combination meter. Refer to [IP-13, "COMBINATION METER"](#).

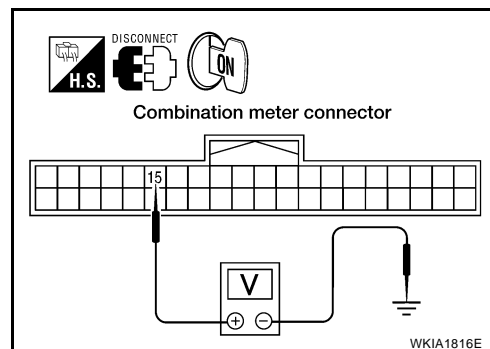

3. CHECK HARNESS FOR OPEN OR SHORT CIRCUIT

1. Turn ignition switch OFF.
2. Disconnect combination meter connector M24.
3. Check continuity between combination meter harness connector M24 (B) terminal 15 and fuel level sensor unit and fuel pump harness connector C5 (A) terminal 2.

Continuity should exist.

4. Check continuity between fuel level sensor unit and fuel pump harness connector C5 (A) terminal 2 and ground.

Continuity should not exist.

OK or NG

- OK >> GO TO 4.
- NG >> Repair harness or connector.

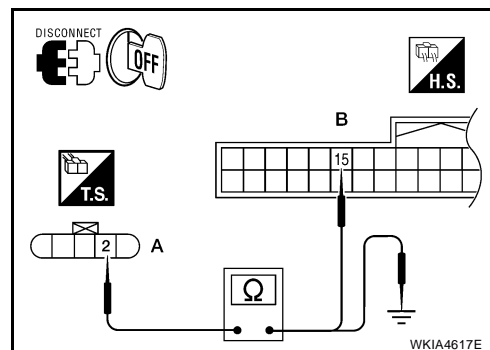

COMBINATION METERS

4. CHECK FUEL LEVEL SENSOR CIRCUIT

1. Check continuity between combination meter harness connector M24 (B) terminal 16 and fuel level sensor unit and fuel pump harness connector C5 (A) terminal 5.

Continuity should exist.

2. Check continuity between fuel level sensor unit and fuel pump harness connector C5 (A) terminal 5 and ground.

Continuity should not exist.

OK or NG

- OK >> GO TO 5.
- NG >> Repair harness or connector.

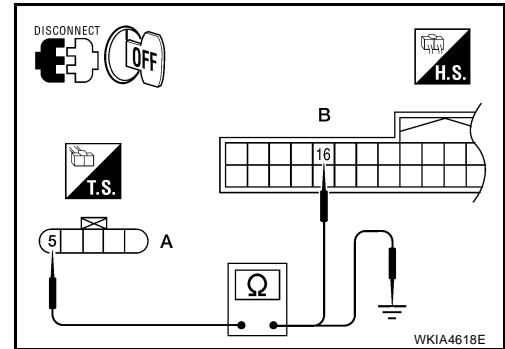

5. CHECK FUEL LEVEL SENSOR UNIT

Check the fuel level sensor unit. Refer to [DI-22, "FUEL LEVEL SENSOR UNIT CHECK"](#).

OK or NG

- OK >> GO TO 6.
- NG >> Replace the fuel level sensor unit. Refer to [FL-5, "Removal and Installation"](#).

6. CHECK INSTALLATION CONDITION

Check fuel level sensor unit installation, and determine whether the float arm interferes or binds with any of the internal components in the fuel tank.

OK or NG

- OK >> Replace the combination meter. Refer to [IP-13, "COMBINATION METER"](#).
- NG >> Install the fuel level sensor unit properly.

Fuel Gauge Fluctuates, Indicates Wrong Value, or Varies

EKS00AD8

1. CHECK FUEL GAUGE FLUCTUATION

Test drive vehicle to see if gauge fluctuates only during driving or just before or just after stopping.

Does the indication value vary only during driving or just before or just after stopping?

- YES >> The fluctuation may be caused by fuel level change in the fuel tank. Condition is normal.
- NO >> Ask the customer about the situation when the symptom occurs in detail, Refer to [DI-20, "Fuel Level Sensor Unit Inspection"](#).

Fuel Gauge Does Not Move to Full-position

EKS00AD9

1. CHECK POINTER MOVEMENT TO FULL-POSITION

Does it take a long time for the pointer to move to full-position?

YES or NO

- YES >> GO TO 2.
- NO >> GO TO 3.

2. CHECK IGNITION SWITCH POSITION

Was the vehicle fueled with the ignition switch ON?

YES or NO

- YES >> Be sure to fuel the vehicle with the ignition switch OFF. Otherwise, it will take a long time for the pointer to move to full-position because of the characteristic of the fuel gauge.
- NO >> GO TO 3.

COMBINATION METERS

3. OBSERVE VEHICLE POSITION

Is the vehicle parked on an incline?

YES or NO

- YES >> Check the fuel level indication with vehicle on a level surface.
- NO >> GO TO 4.

4. CHECK POINTER MOVEMENT TO EMPTY-POSITION

During driving, does the fuel gauge move gradually toward empty-position?

YES or NO

- YES >> Check the fuel level sensor unit. Refer to [DI-22, "FUEL LEVEL SENSOR UNIT CHECK"](#) .
- NO >> Check fuel level sensor unit installation, and determine whether the float arm interferes or binds with any of the internal components in the fuel tank.

Electrical Components Inspection FUEL LEVEL SENSOR UNIT CHECK

EKS00ADA

For removal, refer to [FL-5, "Removal and Installation"](#) .

Check Fuel Level Sensor Unit and Fuel Pump

Check resistance between fuel level sensor unit and fuel pump connector terminals 2 and 5.

Terminals		Float position		mm (in)	Resistance value Ω (Approx.)
2	5	*1	Empty	25.86 (1.02)	81.66
		*2	Full	254.6 (10.02)	6.98

*1 and *2: When float rod is in contact with stopper.

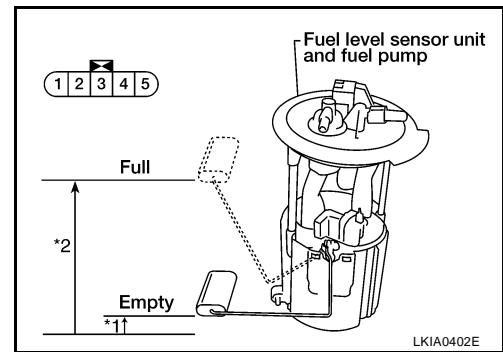

OIL PRESSURE SWITCH CHECK

Check continuity between the oil pressure switch and body ground.

Condition	Oil pressure kPa (kg/cm ² , psi)	Continuity
Engine stopped	Less than 29 (0.3, 4)	Yes
Engine running	More than 29 (0.3, 4)	No

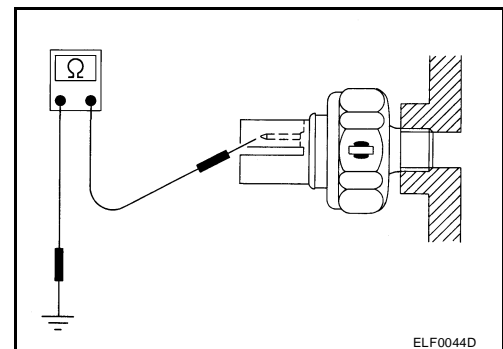

Removal and Installation of Combination Meter

EKS00ADB

Refer to [IP-13, "COMBINATION METER"](#) .

COMPASS AND THERMOMETER

COMPASS AND THERMOMETER

PF24835

System Description

EKS00D78

This unit displays the following items:

- Earth magnetism and heading direction of vehicle.
- Outside air temperature.
- Caution for frozen road surfaces.

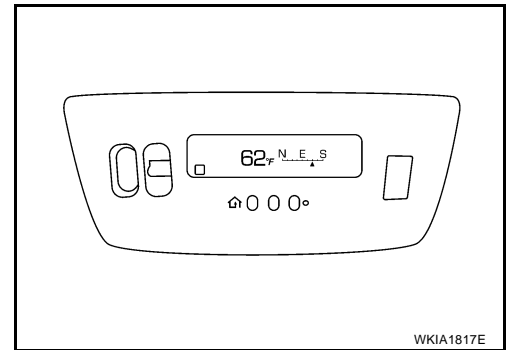

OUTSIDE TEMPERATURE DISPLAY

Push the mode switch when the ignition switch is in the ON position. The outside temperature will be displayed in "°F".

- Selecting the indication range
Push the mode switch to change from °F → °C → OFF → °F.
- The indicated temperature on the thermometer is not readily affected by engine heat. It changes only when one of the following conditions is present.
 - The temperature detected by the ambient sensor is lower than the indicated temperature on the thermometer.
 - The vehicle speed is greater than 20 km/h (12 MPH).
(This is to prevent the indicated temperature from being affected by engine heat during low-speed driving.)
 - The ignition switch has been turned to the OFF position for more than 2 hours. (The engine is cold.)

DIRECTION DISPLAY

Push the mode switch when the ignition switch is in the ON position. The direction will be displayed.

A

B

C

D

E

F

G

H

I

J

DI

L

M

COMPASS AND THERMOMETER

Wiring Diagram — COMPAS —

EKS00D79

DI-COMPAS-01

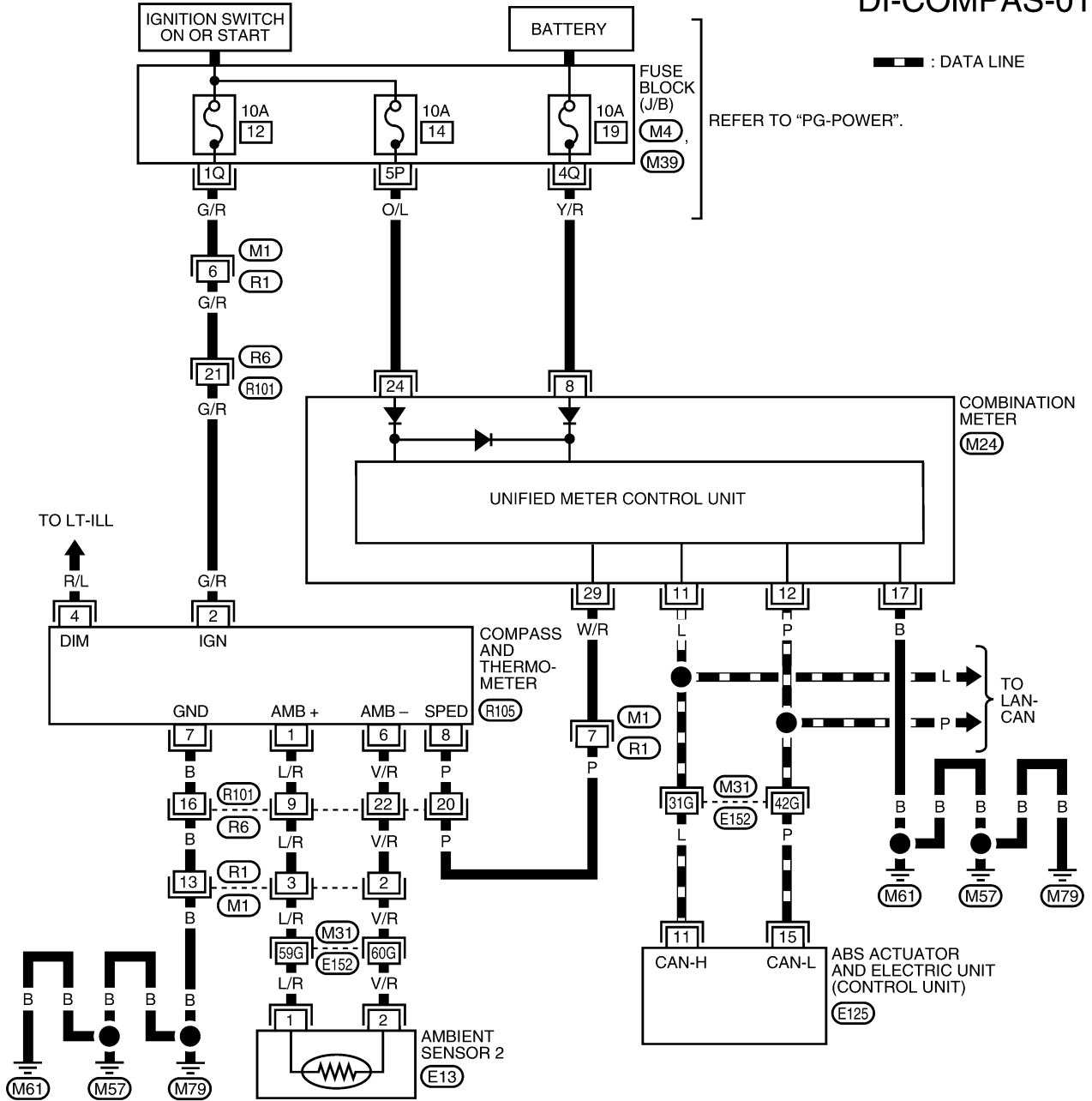

— : DATA LINE

REFER TO "PG-POWER".

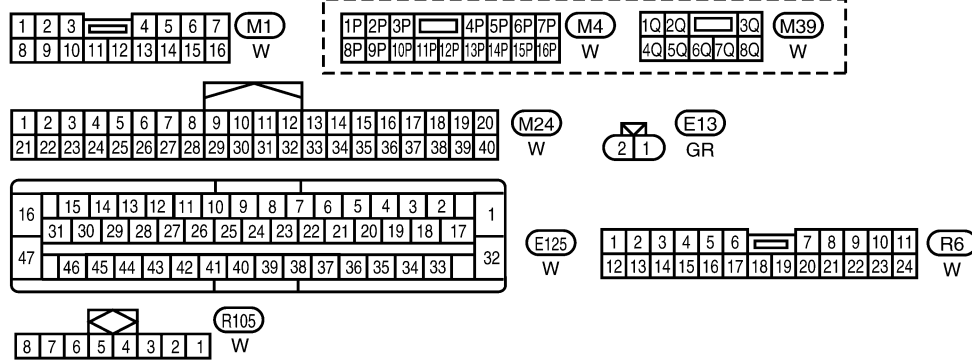

REFER TO THE FOLLOWING.

(M31) - SUPER MULTIPLE JUNCTION (SMJ)

WKWA3710E

COMPASS AND THERMOMETER

EKS00D7A

Trouble Diagnoses

PRELIMINARY CHECK FOR THERMOMETER

1. COOL DOWN CHECK

1. Turn the ignition switch to the ON position.
2. Cool down ambient sensor 2 with water or ice.

Does the indicated temperature drop?

YES >> GO TO 2.

NO >> The system is malfunctioning. Refer to [DI-25, "INSPECTION/COMPASS AND THERMOMETER"](#)

2. WARM UP CHECK

1. Leave the vehicle for 10 minutes.
2. With the ignition switch in the ON position, disconnect and reconnect ambient sensor 2 connector.

Does the indicated temperature rise?

YES >> The system is OK.

NO >> The system is malfunctioning. Refer to [DI-25, "INSPECTION/COMPASS AND THERMOMETER"](#)

NOTE:

The indicated temperature on the thermometer is not readily affected by engine heat. It changes only when one of the following conditions is present.

- The temperature detected by ambient sensor 2 is lower than the indicated temperature on the thermometer.
- The vehicle speed is greater than 20 km/h (13 MPH).
(This is to prevent the indicated temperature from being affected by engine heat during low-speed driving.)
- The ignition switch has been turned to the OFF position for more than 2 hours. (The engine is cold.)

INSPECTION/COMPASS AND THERMOMETER

Symptom	Possible causes	Repair order
No display at all	<ol style="list-style-type: none"> 1. 10A fuse 2. Ground circuit 3. Compass and thermometer 	<ol style="list-style-type: none"> 1. Check 10A fuse [No. 12, located in fuse block (J/B)]. Turn the ignition switch ON and verify that battery positive voltage is at terminal 2 of compass and thermometer. 2. Check ground circuit for compass and thermometer. 3. Replace compass and thermometer.
Forward direction indication slips off the mark or incorrect	<ol style="list-style-type: none"> 1. In manual correction mode (Bar and display vanish) 2. Zone variation change is not done 	<ol style="list-style-type: none"> 1. Drive the vehicle and turn at an angle of 90°. 2. Perform the zone variation change.
Compass reading remains unchanged	<ol style="list-style-type: none"> 1. Vehicle speed signal is not entered 2. Compass and thermometer 	<ol style="list-style-type: none"> 1. Check harness for open or short between combination meter terminal 29 and compass and thermometer terminal 8. 2. Replace compass and thermometer.
Displays wrong temperature when ambient temperature is between -40°C (-40°F) and 55°C (130°F) (See NOTE above)	<ol style="list-style-type: none"> 1. Check operation 2. Ambient sensor circuit 3. Vehicle speed signal is not entered 4. Ambient sensor 2 5. Compass and thermometer 	<ol style="list-style-type: none"> 1. Perform preliminary check shown above. 2. Check harness for open or short between ambient sensor 2 and compass and thermometer. 3. Check harness for open or short between combination meter terminal 29 and compass and thermometer terminal 8. 4. Replace ambient sensor 2. 5. Replace compass and thermometer.
Displays SC or OC	<ol style="list-style-type: none"> 1. Ambient sensor circuit 2. Ambient sensor 2 3. Compass and thermometer 	<ol style="list-style-type: none"> 1. Check harness for open or short between ambient sensor 2 and compass and thermometer. 2. Replace ambient sensor 2. 3. Replace compass and thermometer.

COMPASS AND THERMOMETER

EKS00D7B

Calibration Procedure for Compass

The difference between magnetic North and geographical North can sometimes be great enough to cause false compass readings. In order for the compass to operate accurately in a particular zone, it must be calibrated using the following procedure.

Zone Variation Chart

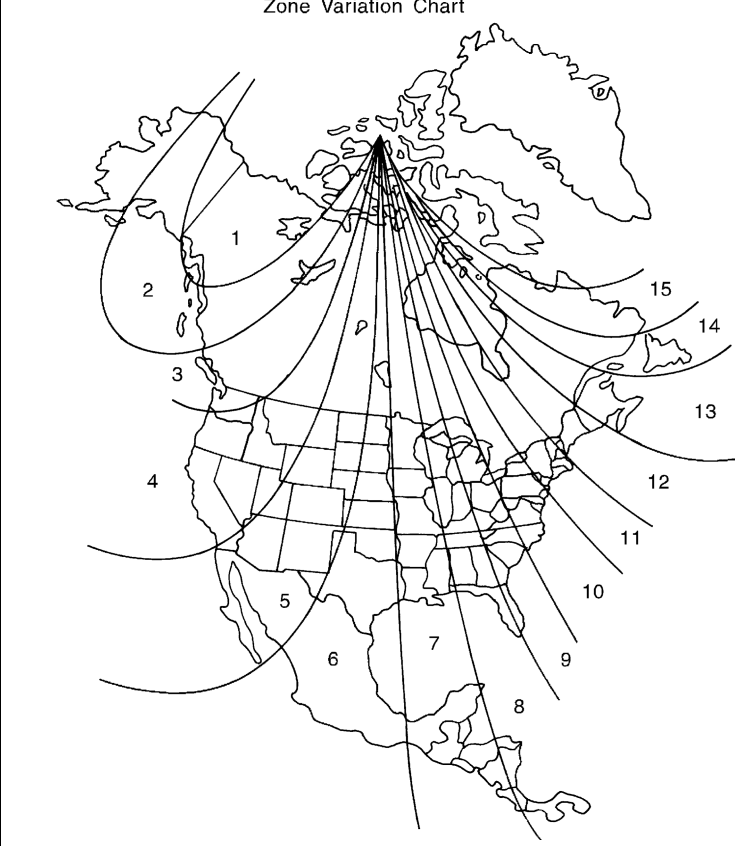

1. Determine your location on the zone map. Record your zone number.

2. Turn the ignition switch to the ON position.

3. Press and hold the mode switch for about 5 seconds. The current zone number will appear in the display.

4. Press the mode switch repeatedly until the desired number appears in the display.

Once the desired zone number is displayed, stop pressing the mode switch and the display will show a compass direction after a few seconds.

NOTE: Use zone number 5 for Hawaii.

WKIA3604E

CORRECTION FUNCTIONS OF COMPASS

The direction display is equipped with automatic correction function. If the direction is not shown correctly, carry out initial correction.

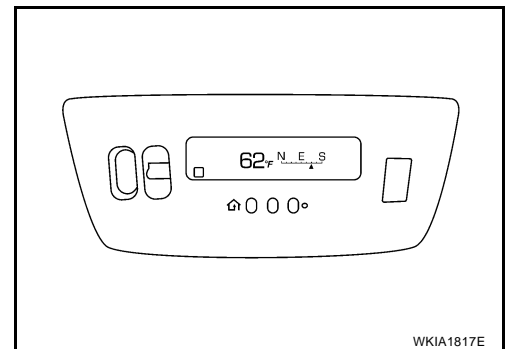

INITIAL CORRECTION PROCEDURE FOR COMPASS

1. Pushing the mode switch for about 10 seconds will enter the initial correction mode. The compass display will begin to flash.
2. Turn the vehicle slowly in an open, safe place. The initial correction is completed in approximately one and a half turns.

NOTE:

In places where the terrestrial magnetism is extremely disturbed, the initial correction may start automatically.

WARNING LAMPS

WARNING LAMPS

Schematic

PF24814

EKS00ADG

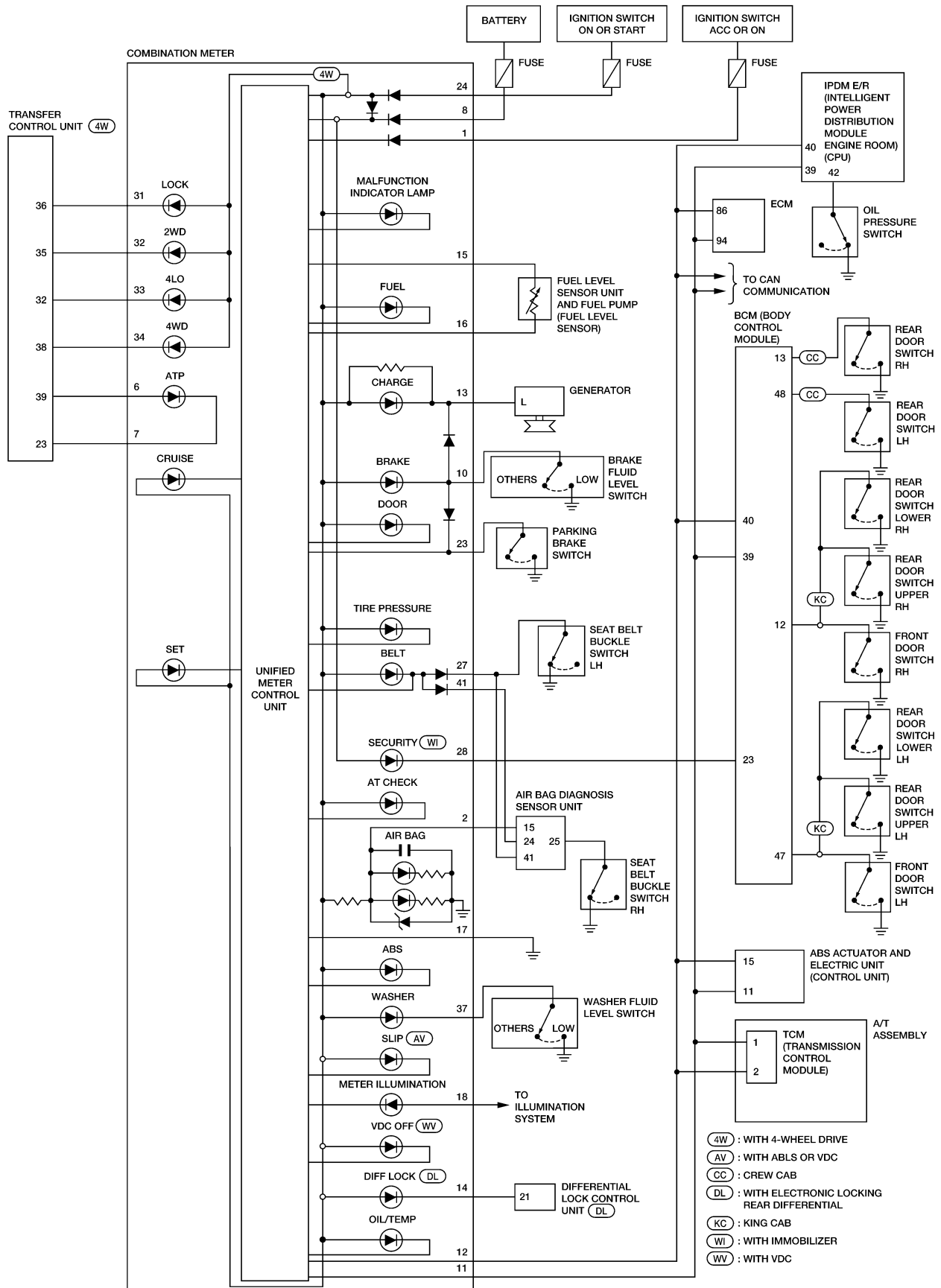

WKWA5163E

WARNING LAMPS

Wiring Diagram — WARN —

EKS00ADH

DI-WARN-01

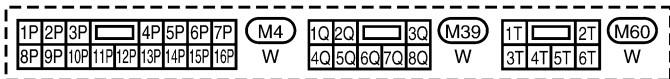
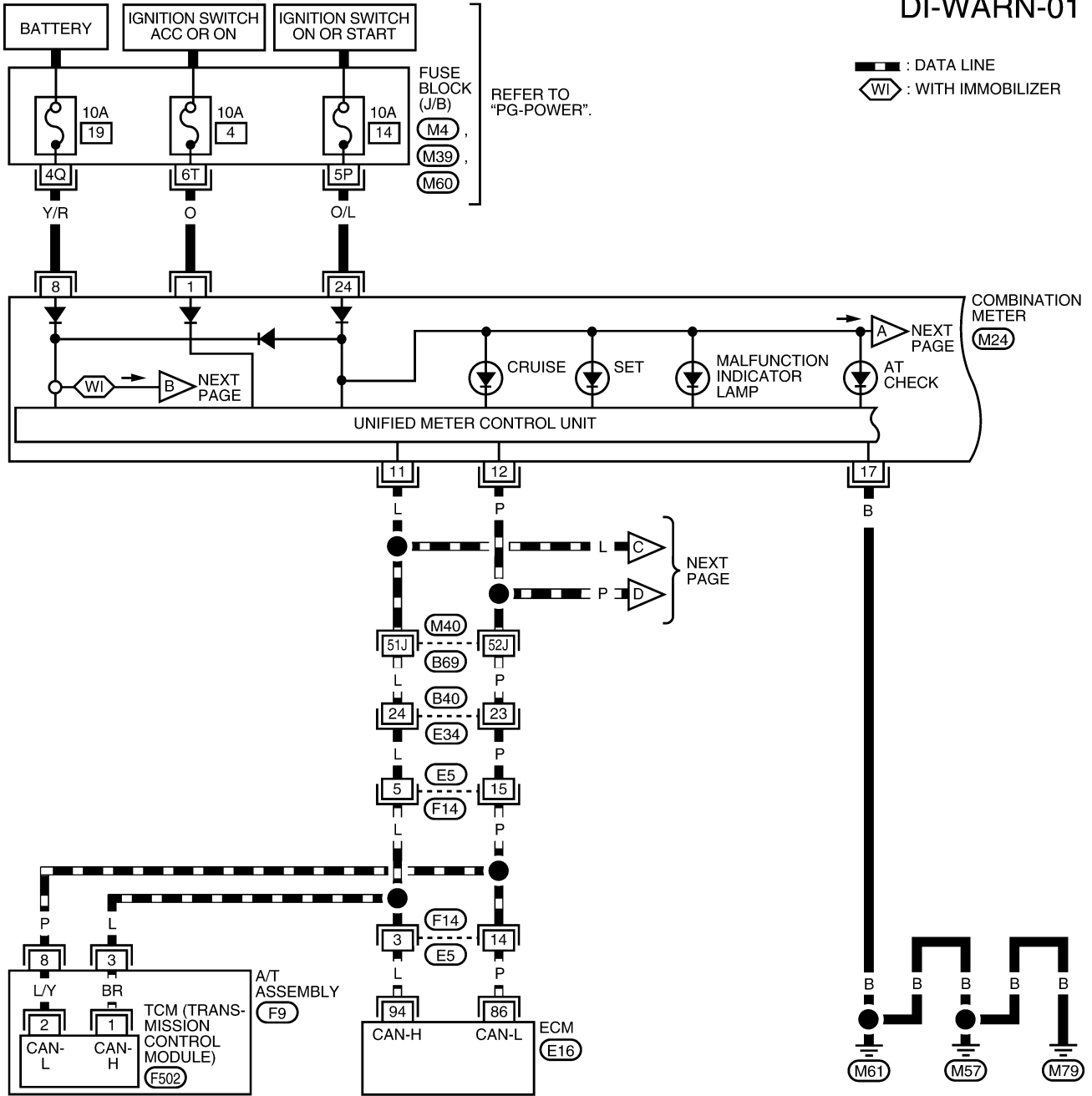

REFER TO THE FOLLOWING.
 (E16) - ELECTRICAL UNITS
 (M40) - SUPER MULTIPLE JUNCTION (SMJ)

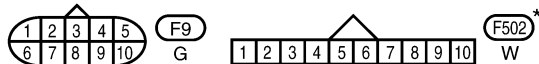
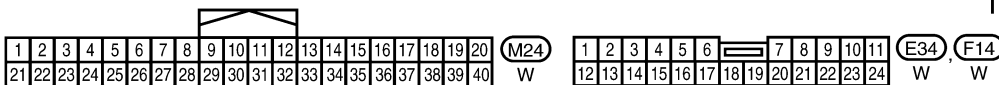

*: THIS CONNECTOR IS NOT SHOWN IN "HARNESS LAYOUT" OF PG SECTION.

WKWA5164E

WARNING LAMPS

DI-WARN-02

— : DATA LINE

AV : WITH ABLs OR VDC

WV : WITH VDC

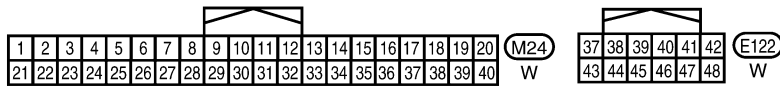
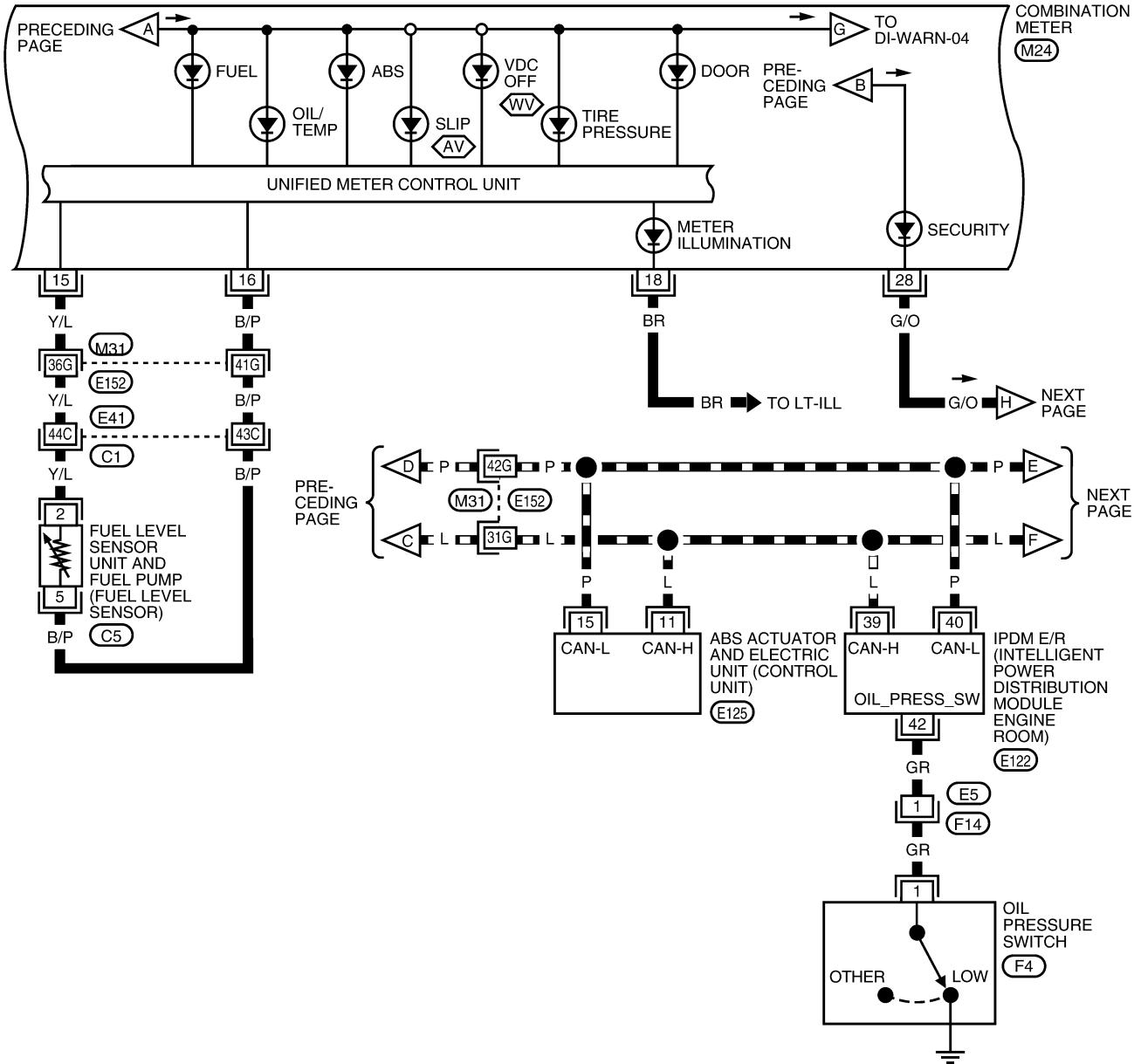

REFER TO THE FOLLOWING.
 M31, C1 - SUPER
 MULTIPLE JUNCTION (SMJ)

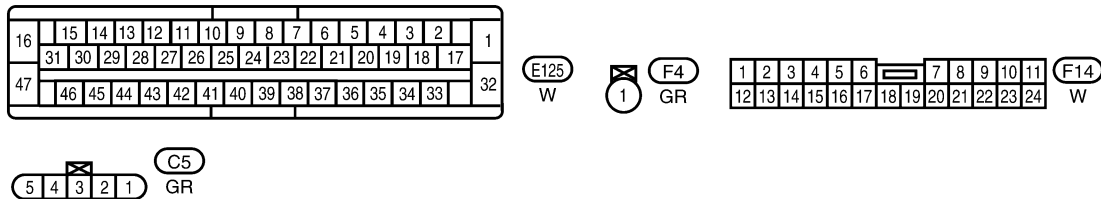

WKWA5165E

WARNING LAMPS

DI-WARN-03

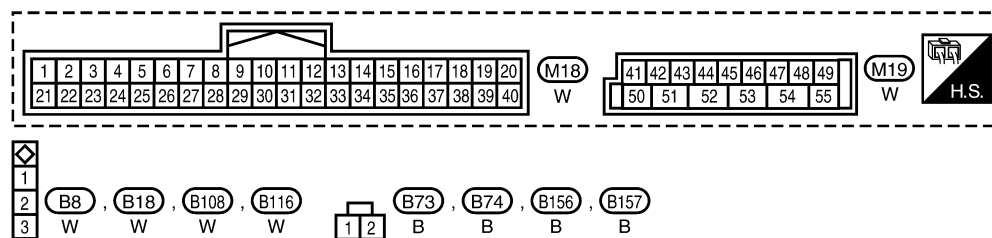
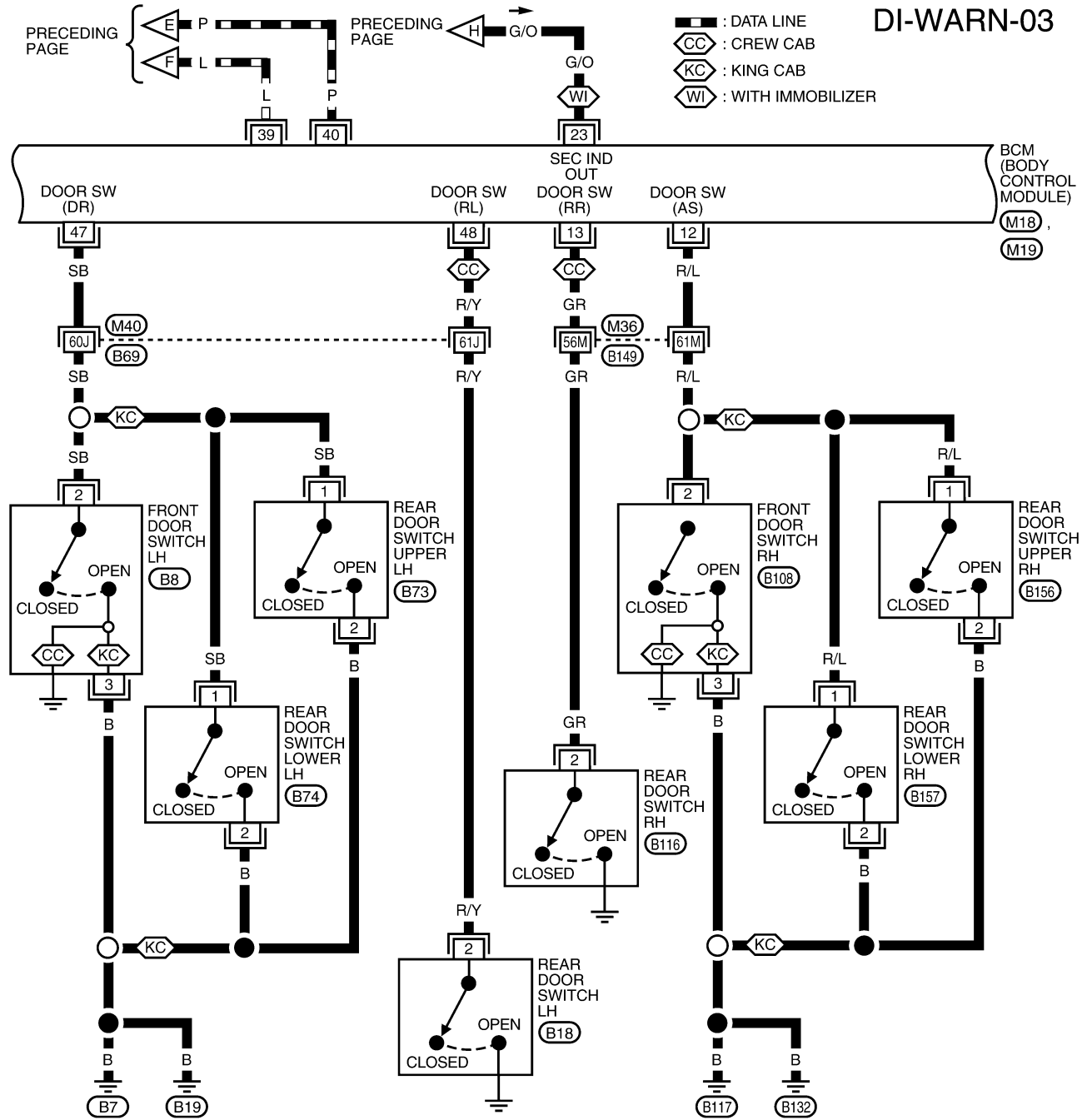

REFER TO THE FOLLOWING.
 (M36), (M40) - SUPER
 MULTIPLE JUNCTION (SMJ)

WKWA5166E

WARNING LAMPS

DI-WARN-04

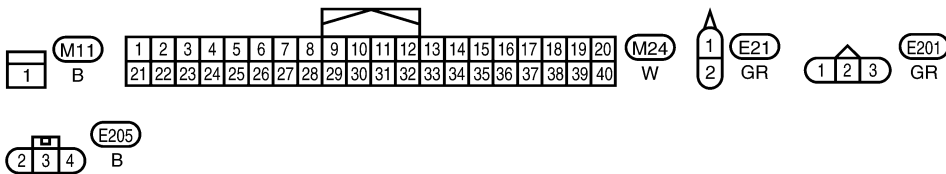
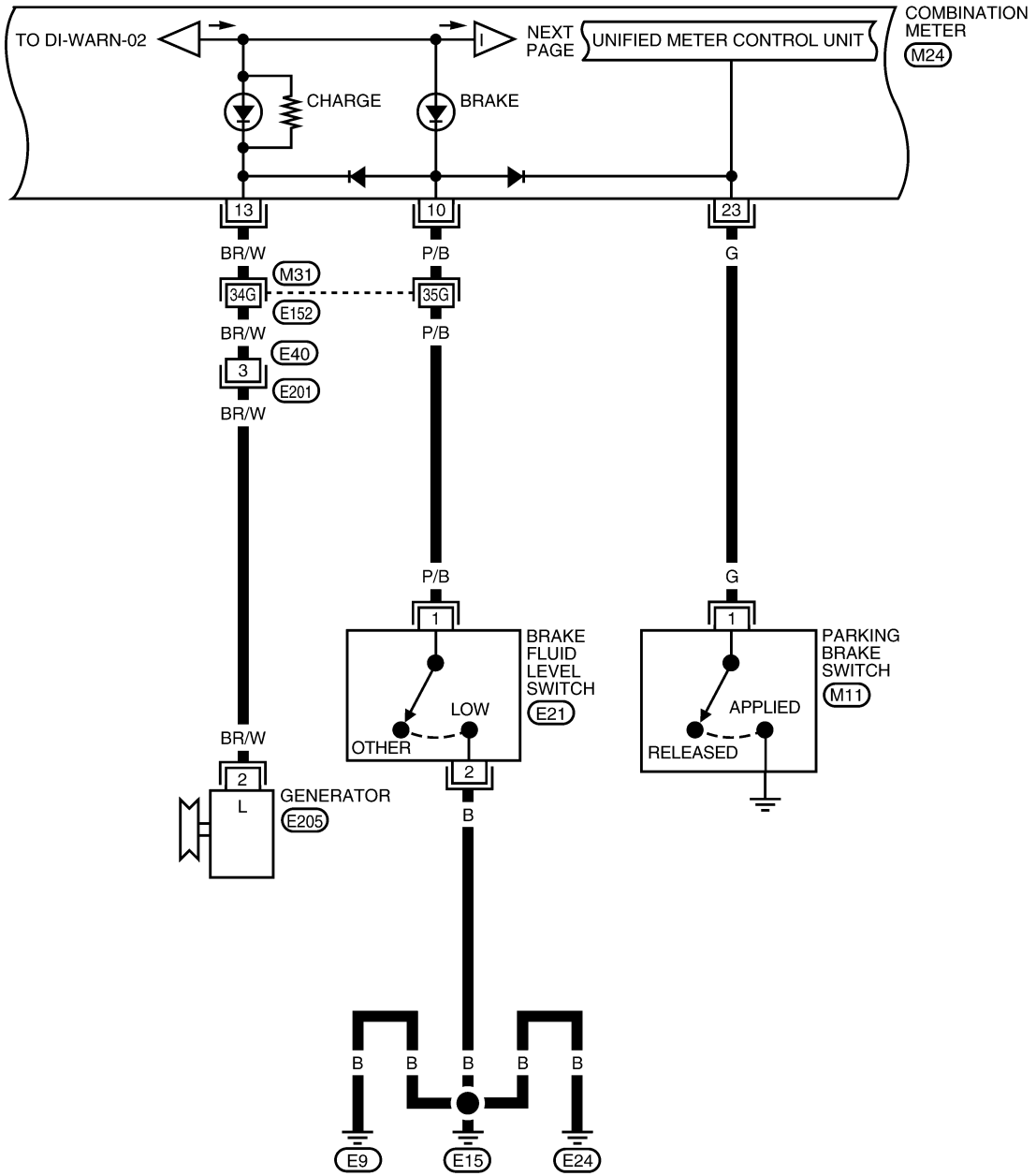

REFER TO THE FOLLOWING.
 (M31) - SUPER MULTIPLE JUNCTION (SMJ)

WKWA5167E

WARNING LAMPS

DI-WARN-05

DL : WITH ELECTRONIC LOCKING REAR DIFFERENTIAL
 4W : WITH 4-WHEEL DRIVE

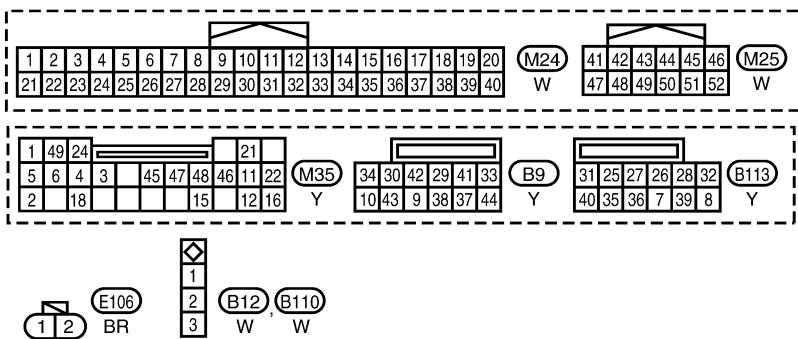
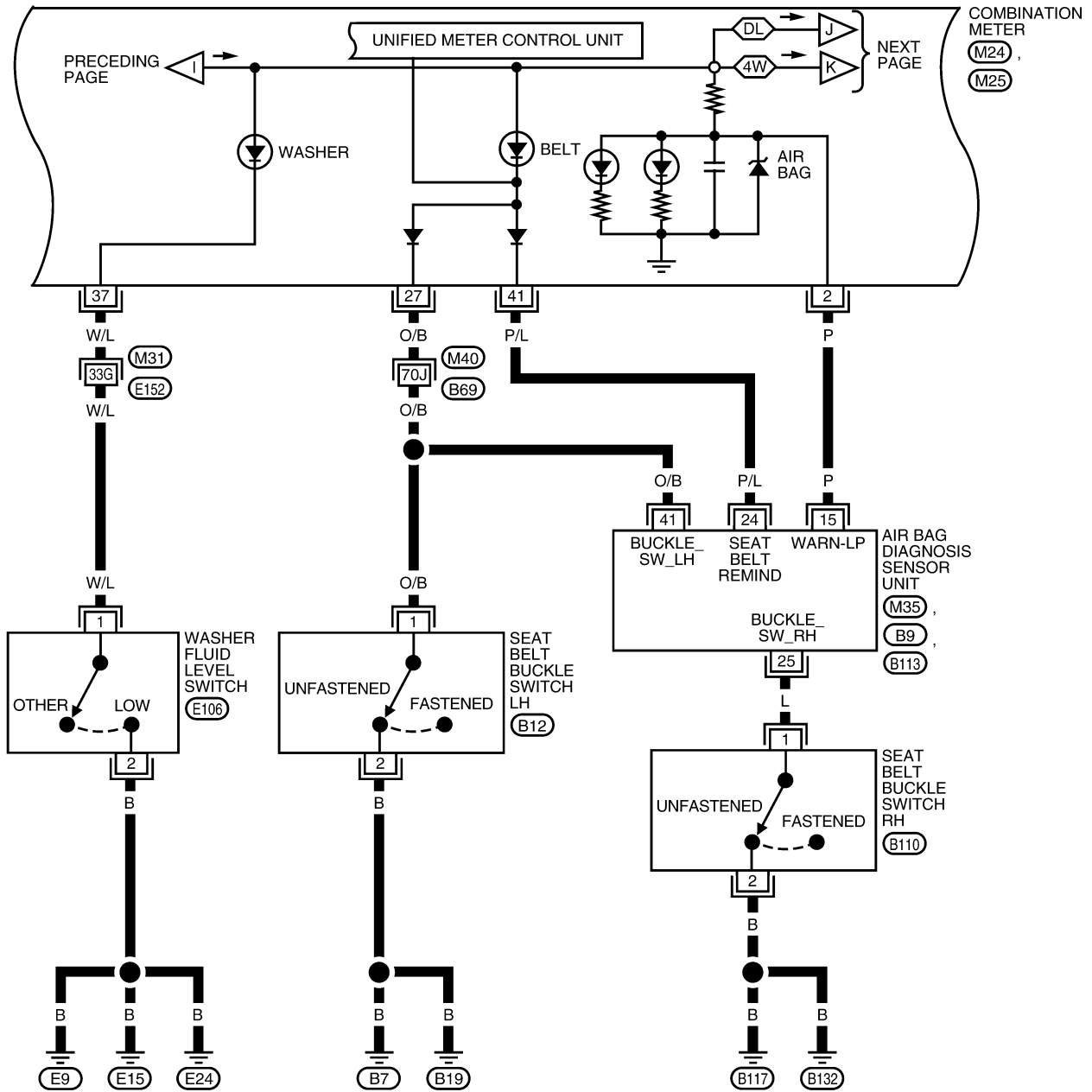

REFER TO THE FOLLOWING.
 M31, M40 - SUPER
 MULTIPLE JUNCTION (SMJ)

WKWA5168E

WARNING LAMPS

4WD Models

DI-WARN-06

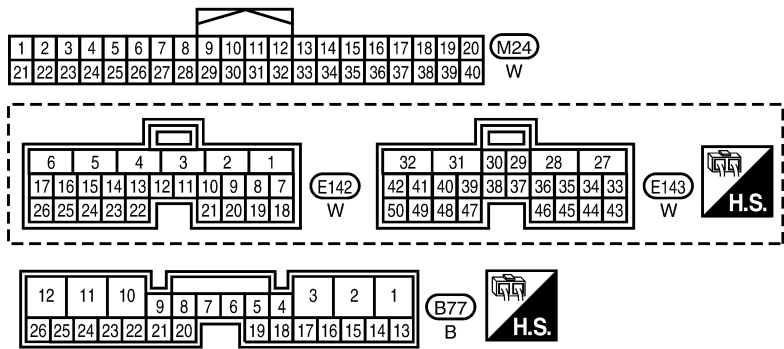
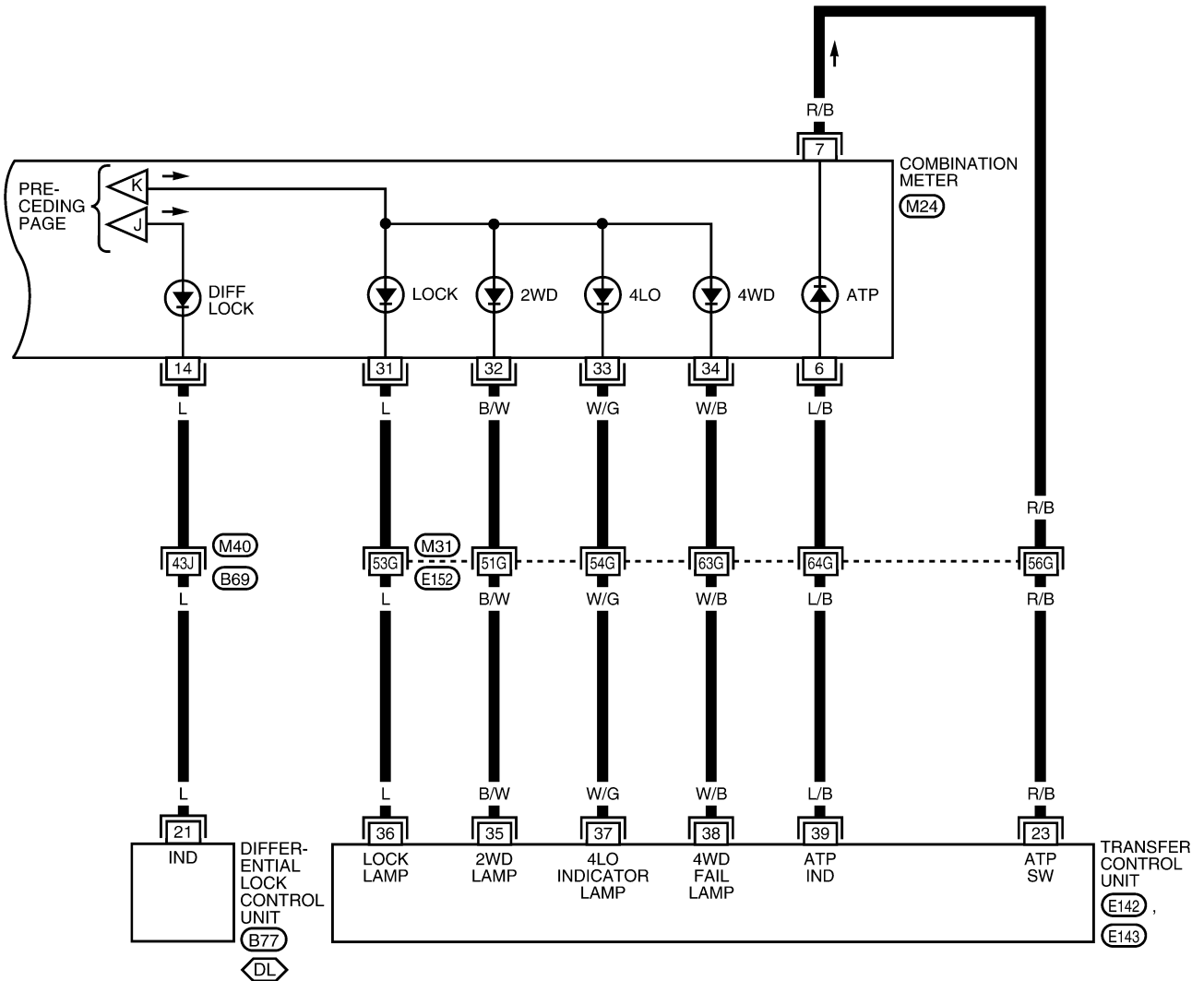

REFER TO THE FOLLOWING.
 (M31), (M40) - SUPER MULTIPLE JUNCTION (SMJ)

WKWA5169E

WARNING LAMPS

EKS00D7C

Oil Pressure Warning Lamp Stays Off (Ignition Switch ON)

1. CHECK SELF-DIAGNOSTIC RESULTS OF IPDM E/R

Select "IPDM E/R" on CONSULT-II, and perform self-diagnosis of IPDM E/R. Refer to [PG-20, "SELF-DIAGNOSTIC RESULTS"](#).

Self-diagnostic results content

No malfunction detected>>GO TO 2.

Malfunction detected>>GO TO [PG-20, "Display Item List"](#).

2. CHECK IPDM E/R INPUT SIGNAL

Select "IPDM E/R" on CONSULT-II. Operate ignition switch with "OIL P SW" of "DATA MONITOR" and check operation status.

When ignition switch is in ON : OIL P SW CLOSE position (Engine stopped)

When engine running : OIL P SW OPEN

OK or NG

OK >> Replace combination meter. Refer to [IP-13, "COMBINATION METER"](#).

NG >> GO TO 3.

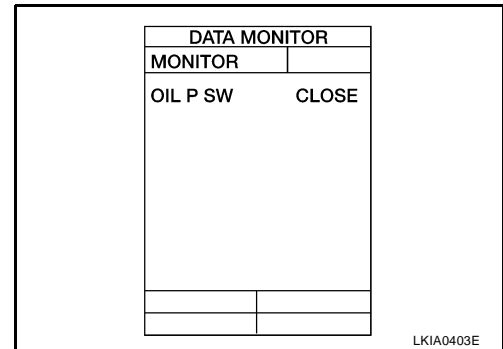

3. CHECK OIL PRESSURE SWITCH CIRCUIT

1. Turn ignition switch OFF.
2. Disconnect IPDM E/R connector E122 and oil pressure switch connector F4.
3. Check continuity between IPDM E/R harness connector E122 (A) terminal 42 and oil pressure switch harness connector F4 (B) terminal 1.

Continuity should exist.

OK or NG

OK >> GO TO 4.

NG >> Repair harness or connector.

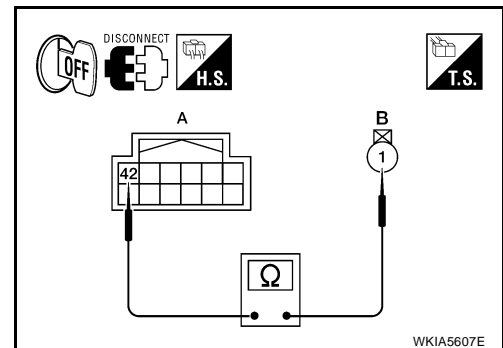

4. CHECK OIL PRESSURE SWITCH

Check oil pressure switch. Refer to [DI-22, "OIL PRESSURE SWITCH CHECK"](#).

OK or NG

OK >> Replace IPDM E/R. Refer to [PG-30, "Removal and Installation of IPDM E/R"](#).

NG >> Replace oil pressure switch.

Oil Pressure Warning Lamp Does Not Turn Off (Oil Pressure Is Normal)

EKS00D7D

NOTE:

For oil pressure inspection, refer to [LU-8, "OIL PRESSURE CHECK"](#).

1. CHECK ENGINE OIL PRESSURE GAUGE OPERATION

Observe operation of engine oil pressure gauge.

Does engine oil pressure gauge function properly?

YES >> Replace the combination meter. Refer to [IP-13, "COMBINATION METER"](#).

NO >> GO TO [DI-19, "Engine Oil Pressure Signal Inspection"](#).

A/T INDICATOR

PF24814

EKS00ADI

A/T INDICATOR

Wiring Diagram — AT/IND —

DI-AT/IND-01

— — — : DATA LINE

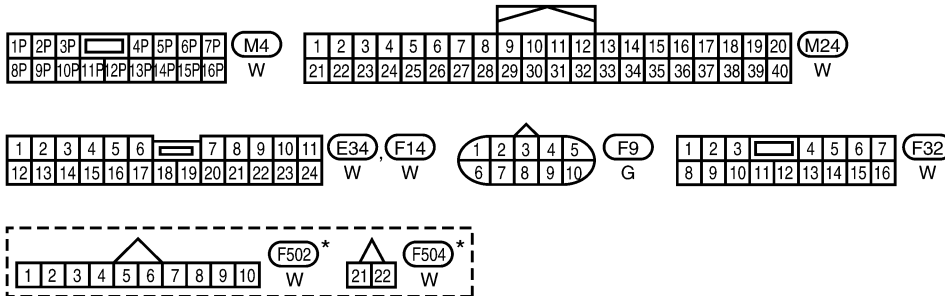
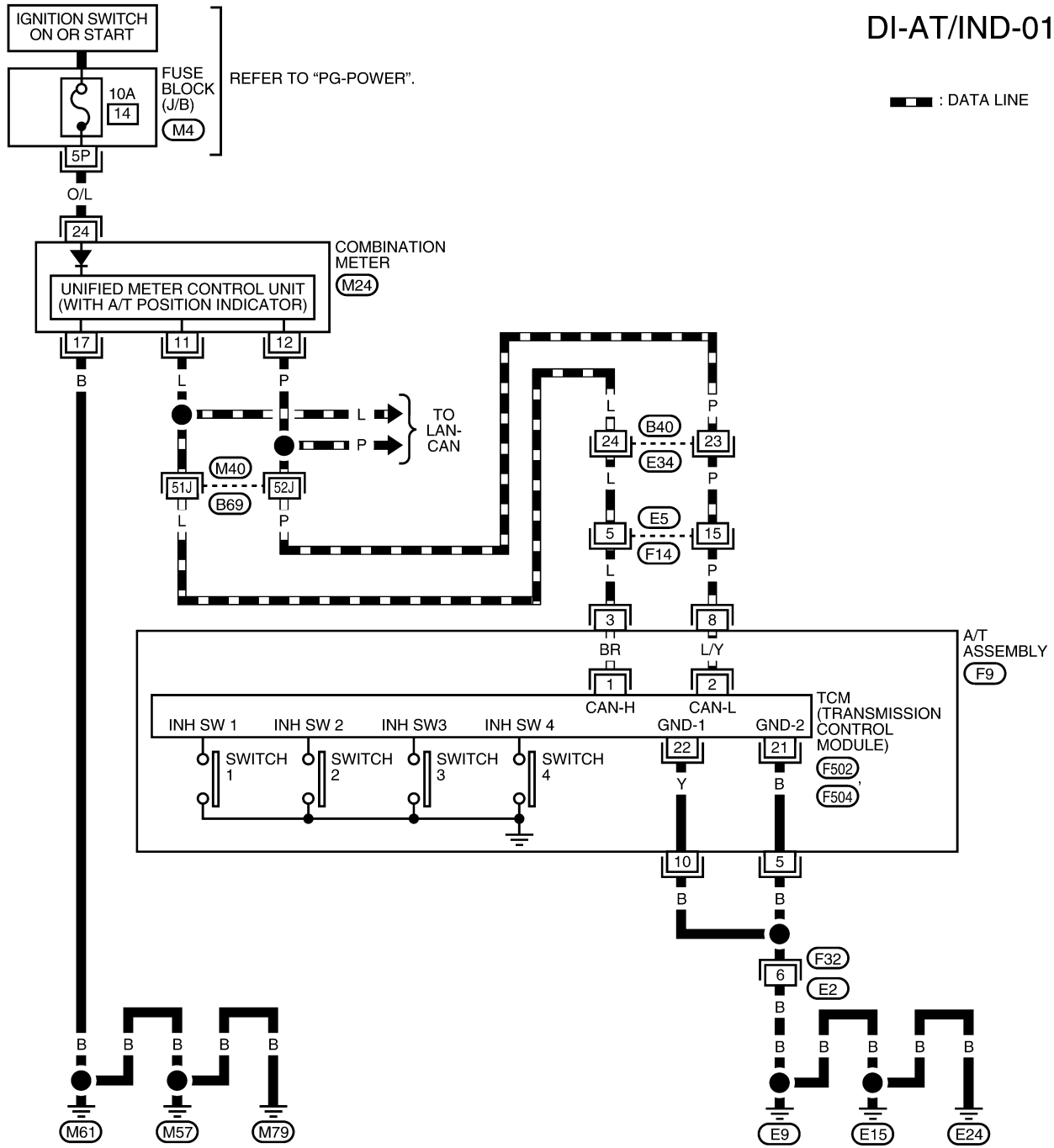

REFER TO THE FOLLOWING.

(M40) - SUPER MULTIPLE JUNCTION (SMJ)

* : THIS CONNECTOR IS NOT SHOWN IN "HARNESS LAYOUT" OF PG SECTION.

WKWA3718E

A/T INDICATOR

A/T Indicator Does Not Illuminate

EKS00ADJ

1. CHECK SELF-DIAGNOSIS OF COMBINATION METER

Perform combination meter self-diagnosis. Refer to [DI-12, "SELF-DIAGNOSIS FUNCTION"](#) .

OK or NG

OK >> GO TO 2.

NG >> Replace combination meter. Refer to [IP-13, "COMBINATION METER"](#) .

2. CHECK TCM

Perform self-diagnosis of TCM. Refer to [AT-89, "SELF-DIAGNOSTIC RESULT MODE"](#) .

OK or NG

OK >> Replace combination meter. Refer to [IP-13, "COMBINATION METER"](#) .

NG >> Refer to [DI-12, "SELF-DIAGNOSIS FUNCTION"](#) .

WARNING CHIME

WARNING CHIME

PFP:24814

Component Parts and Harness Connector Location

EKS00ADK

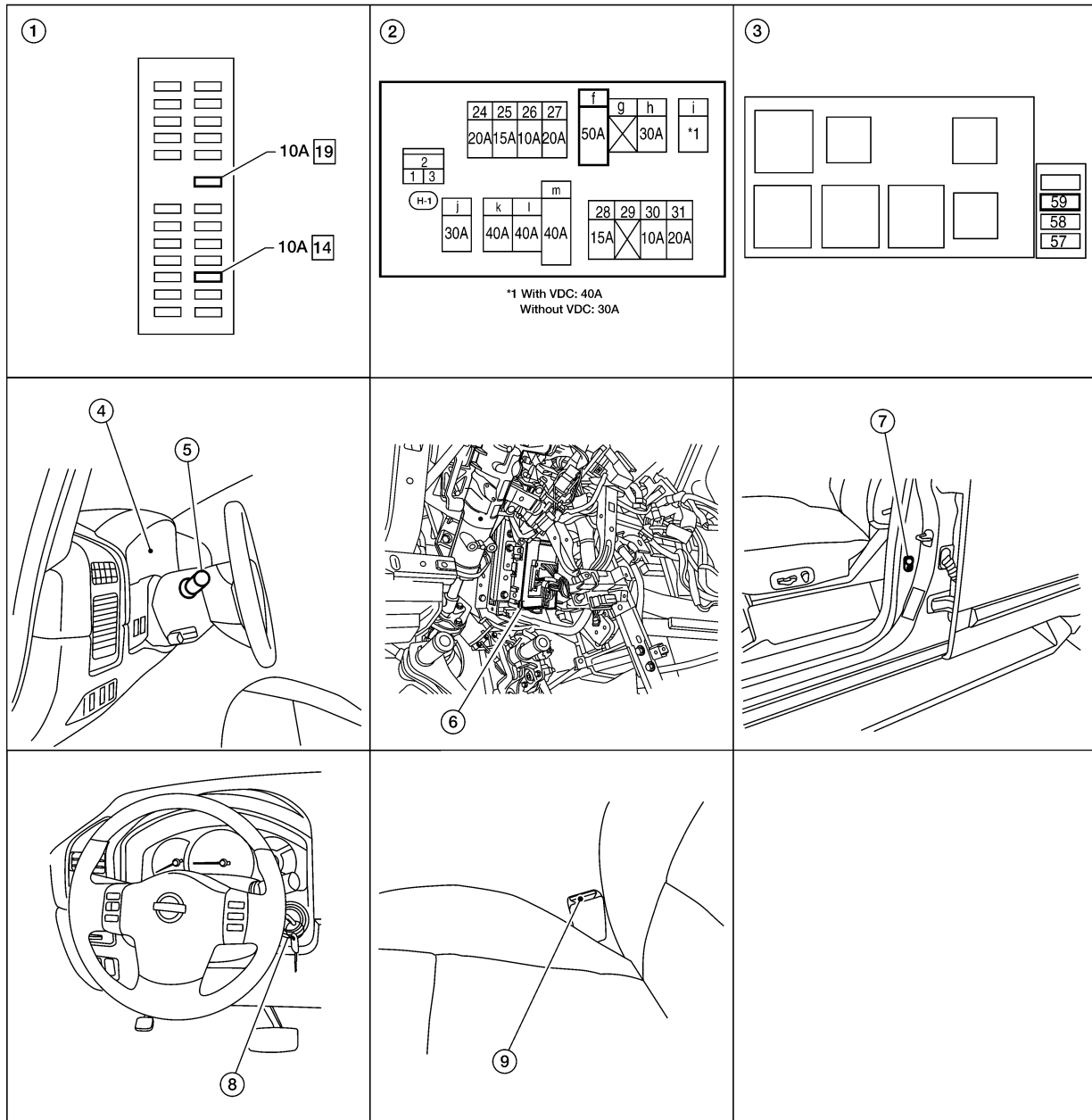

- | | | |
|----------------------------|--|---|
| 1. Fuse block (J/B) | 2. Fuse and fusible link box | 3. Fuse and relay box |
| 4. Combination meter M24 | 5. Combination switch (lighting switch) M28 | 6. BCM M18, M20 (view with instrument lower panel LH removed) |
| 7. Front door switch LH B8 | 8. Key switch and key lock solenoid M27 (floor shift)
Key switch M80 (column shift) | 9. Seat belt buckle switch LH B12 |

WKIA4619E

WARNING CHIME

EKS00ADL

System Description

FUNCTION

Power is supplied at all times

- through 50A fusible link (letter f , located in the fuse and fusible link box)
- to BCM terminal 70,
- through 10A fuse [No. 19, located in the fuse block (J/B)]
- to key switch and key lock solenoid terminal 3 (floor shift) or key switch terminal 3 (column shift).

With ignition switch in ON or START position, power is supplied

- through 10A fuse (No. 59, located in the fuse and relay box)
- to BCM terminal 38,
- through 10A fuse [No. 14, located in the fuse block (J/B)]
- to combination meter terminal 24.

Ground is supplied

- to BCM terminal 67, and
- to combination meter terminal 17
- through body grounds M57, M61, and M79.

NOTE:

When ignition key warning chime, light warning chime, and seat belt warning chime are required at the same time, the priorities for each chime are the following.

1. Light warning chime
2. Ignition key warning chime
3. Seat belt warning chime

IGNITION KEY WARNING CHIME

With the key inserted in the ignition switch, the ignition switch in OFF position, and the driver's door open, the warning chime will sound.

Power is supplied

- through key switch and key lock solenoid terminal 4 (floor shift) or key switch terminal 4 (column shift)
- to BCM terminal 37.

Ground is supplied

- to BCM terminal 47
- through front door switch LH terminal 2
- through body grounds B7 and B19 (king cab) or through front door switch LH case ground (crew cab).

BCM detects key inserted into the ignition switch, and sends key warning signal to combination meter via CAN communication lines. When the combination meter receives key warning signal, it sounds warning chime.

LIGHT WARNING CHIME

With the key removed from the ignition switch, the driver's door open, and the lighting switch (part of the combination switch) in 1st or 2nd position, the warning chime will sound. [Except when headlamp battery saver control operates (5 minutes after ignition switch is turned to OFF or ACC position) and headlamps do not illuminate.]

Signal is supplied

- from combination switch (lighting switch) terminals 1, 2, 3, 4, 5, 6, 7, 8, 9 and 10
- to BCM terminals 2, 3, 4, 5, 6, 32, 33, 34, 35 and 36.

NOTE:

BCM detected lighting switch in 1st or 2nd position. Refer to [LT-76, "Combination Switch Reading Function"](#).

Ground is supplied

- to BCM terminal 47
- through front door switch LH terminal 2.
- through body grounds B7 and B19 (king cab) or through front door switch LH case ground (crew cab).

BCM detects headlamps are illuminated, and sends light warning signal to combination meter CAN communication lines. When the combination meter receives light warning signal, it sounds warning chime.

WARNING CHIME

SEAT BELT WARNING CHIME

When the ignition switch is turned ON with the seat belt unfastened (seat belt buckle switch LH unfastened), warning chime will sound for approximately 6 seconds.

Ground is supplied

- to combination meter terminal 27
- through seat belt buckle switch LH terminal 1.

Seat belt buckle switch LH terminal 2 is grounded through body grounds B7 and B19.

The combination meter sends seat belt buckle switch LH unfastened signal to BCM via CAN communication line.

BCM receives seat belt buckle switch LH unfastened signal from combination meter via CAN communication line, and sends seat belt warning signal to the combination meter via CAN communication line. When the combination meter receives the seat belt warning signal, it sounds the warning chime. The BCM controls the (6 second) duration of the seat belt warning chime.

CAN Communication System Description

EKS00ADM

Refer to [LAN-2, "SYSTEM DESCRIPTION"](#) .

A
B
C
D
E
F
G
H
I
J
L
M

DI

WARNING CHIME

Wiring Diagram — CHIME —

EKS00ADN

DI-CHIME-01

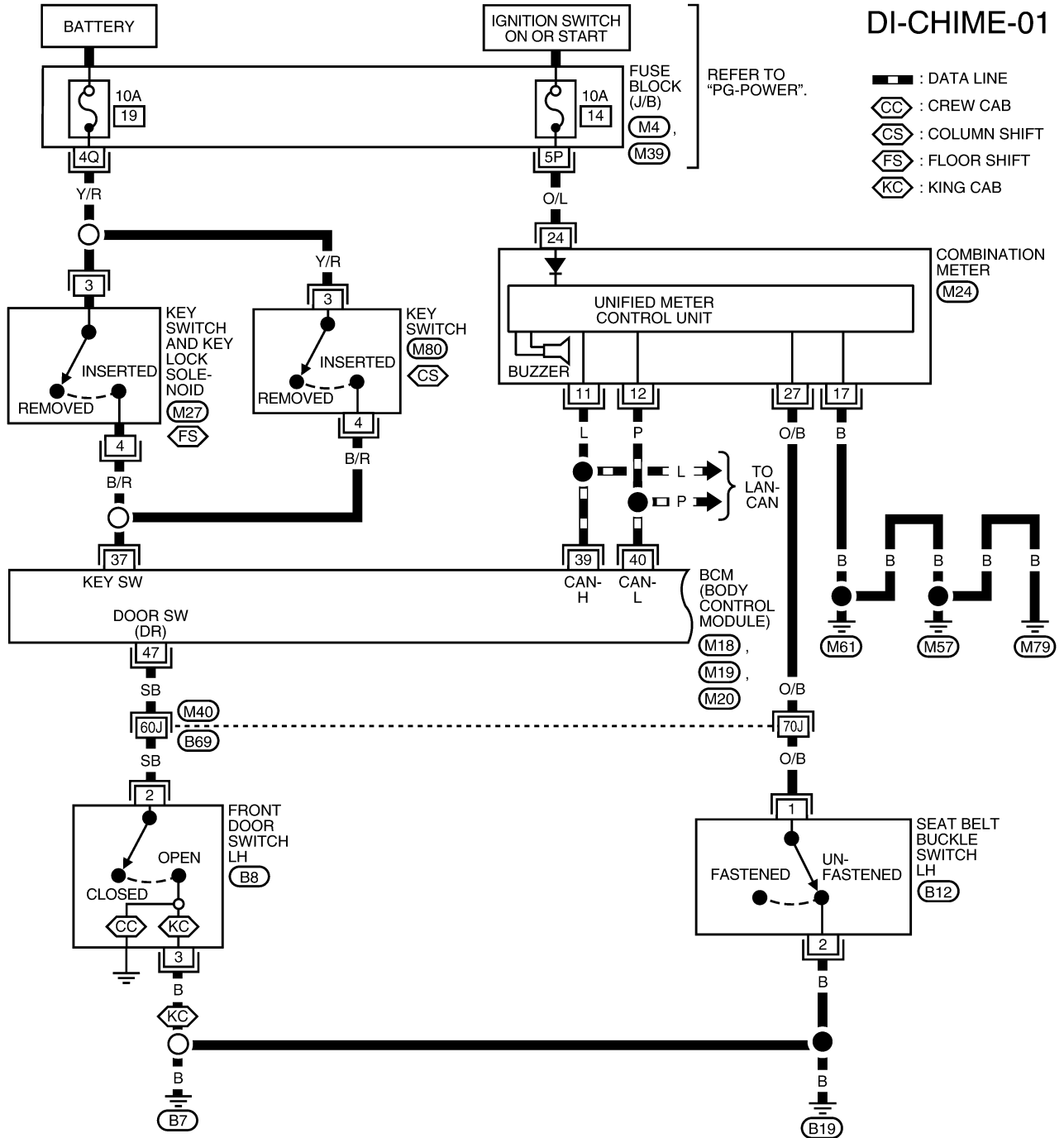

- : DATA LINE
- CC : CREW CAB
- CS : COLUMN SHIFT
- FS : FLOOR SHIFT
- KC : KING CAB

REFER TO "PG-POWER".

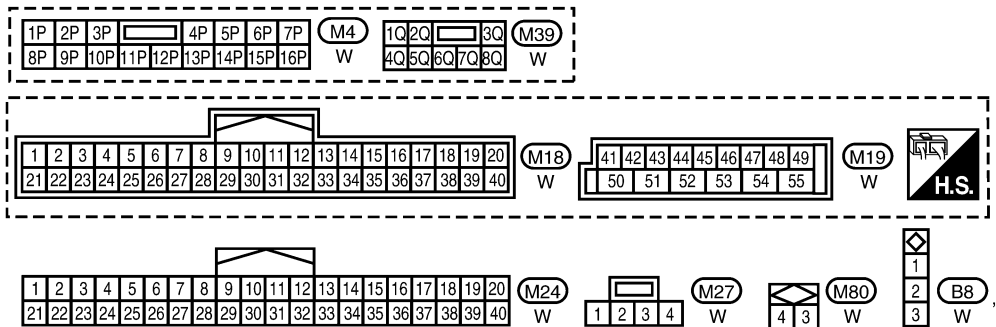

REFER TO THE FOLLOWING.
 M40 - SUPER MULTIPLE JUNCTION (SMJ)

WKWA3719E

WARNING CHIME

DI-CHIME-02

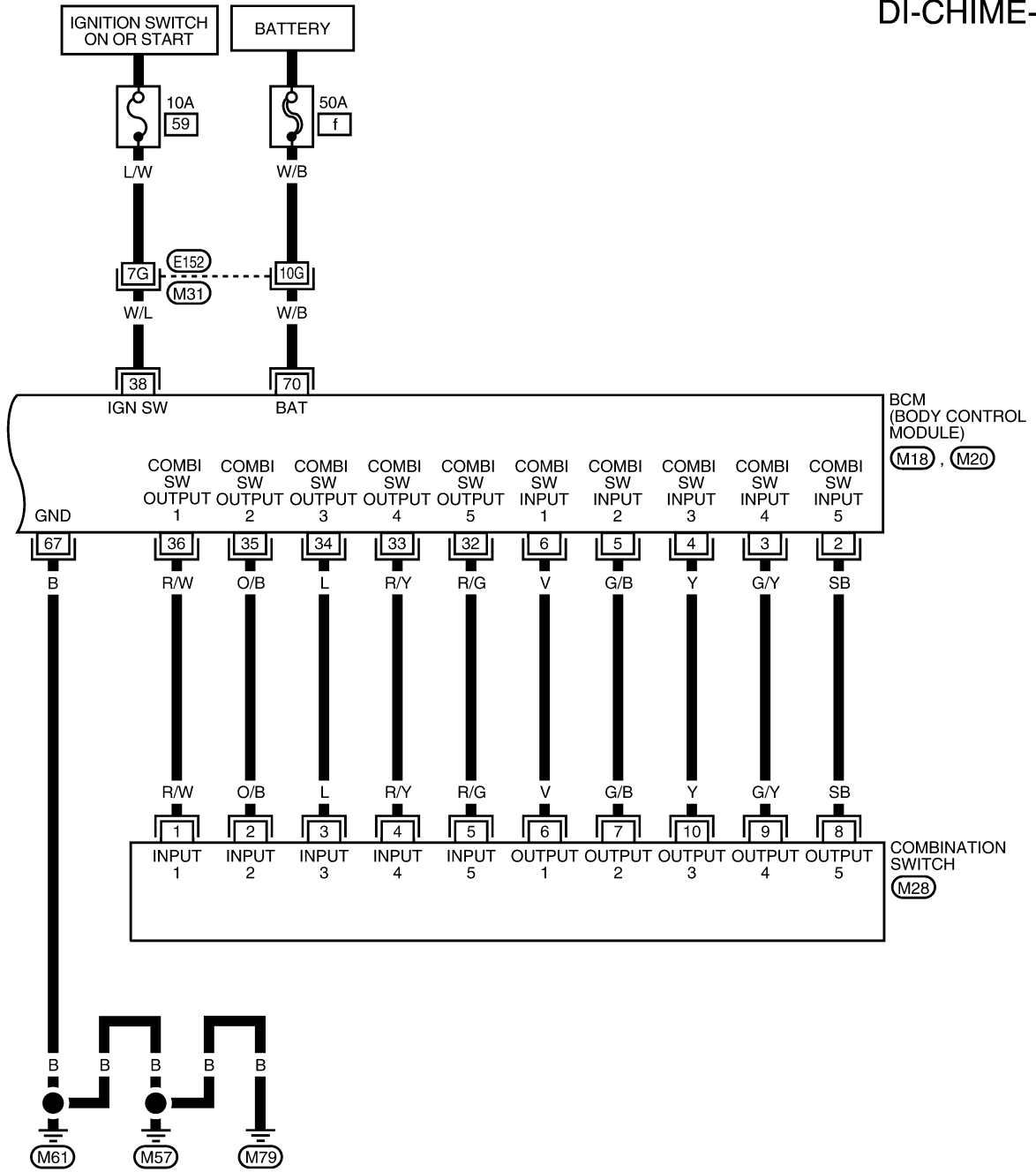

A
B
C
D
E
F
G
H
I
J
DI
L
M

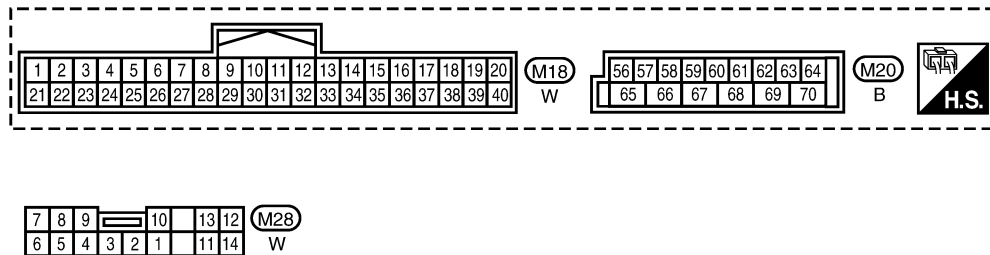

REFER TO THE FOLLOWING.
(M31) - SUPER MULTIPLE JUNCTION (SMJ)



WKWA3720E

WARNING CHIME

Terminals and Reference Values for BCM

EKS00ADO

Refer to [BCS-12, "Terminals and Reference Values for BCM"](#) .

Terminals and Reference Values for Combination Meter

EKS00ADP

Refer to [DI-11, "Terminals and Reference Values for Combination Meter"](#) .

How to Proceed With Trouble Diagnosis

EKS00ADQ

1. Confirm the symptom or customer complaint.
2. Understand operation description and function description. Refer to [DI-38, "System Description"](#) .
3. Perform the preliminary check. Refer to [DI-42, "Preliminary Check"](#) .
4. Check symptom and repair or replace the cause of malfunction.
5. Does the warning chime operate properly? If so, go to 6. If not, go to 3.
6. Inspection End.

Preliminary Check

EKS00ADR

INSPECTION FOR POWER SUPPLY AND GROUND CIRCUIT

Refer to [BCS-16, "BCM Power Supply and Ground Circuit Check"](#) .

WARNING CHIME

CONSULT-II Function (BCM)

EKS00ADS

CONSULT-II can display each diagnostic item using the diagnostic test modes shown following.

BCM diagnostic test item	Diagnostic mode	Description
Inspection by part	WORK SUPPORT	Supports inspections and adjustments. Commands are transmitted to the BCM for setting the status suitable for required operation, input/output signals are received from the BCM and received data is displayed.
	DATA MONITOR	Displays BCM input/output data in real time.
	ACTIVE TEST	Operation of electrical loads can be checked by sending drive signal to them.
	SELF-DIAG RESULTS	Displays BCM self-diagnosis results.
	CAN DIAG SUPPORT MNTR	The result of transmit/receive diagnosis of CAN communication can be read.
	ECU PART NUMBER	BCM part number can be read.
	CONFIGURATION	Performs BCM configuration read/write functions.

CONSULT-II START PROCEDURE

Refer to [GI-38, "CONSULT-II Start Procedure"](#).

DATA MONITOR

Display Item List

Monitored item	Description
IGN ON SW	Indicates [ON/OFF] condition of ignition switch.
KEY ON SW	Indicates [ON/OFF] condition of key switch.
DOOR SW-DR	Indicates [ON/OFF] condition of front door switch (driver side).
LIGHT SW 1ST	Indicates [ON/OFF] condition of lighting switch.
BUCKLE SW	Indicates [ON/OFF] condition of seat belt buckle switch LH.

ACTIVE TEST

Display Item List

Test item	Malfunction is detected when
LIGHT WARN ALM	This test is able to check light warning chime operation. Light warning chime sounds for 2 seconds after touching "ON" on CONSULT-II screen.
IGN KEY WARN ALM	This test is able to check key warning chime operation. Key warning chime sounds for 2 seconds after touching "ON" on CONSULT-II screen.
SEAT BELT WARN TEST	This test is able to check seat belt warning chime operation. Seat belt warning chime sounds for 2 seconds after touching "ON" on CONSULT-II screen.

SELF-DIAGNOSTIC RESULTS

Display Item List

Monitored Item	CONSULT-II display	Description
CAN communication	CAN communication [U1000]	Malfunction is detected in CAN communication.

NOTE:

If "CAN communication [U1000]" is displayed, after printing the monitor item, go to "CAN System". Refer to [LAN-42, "TROUBLE DIAGNOSIS"](#).

WARNING CHIME

EKS00ADT

All Warning Chimes Do Not Operate

1. CHECK BCM CHIME OPERATION

Select "BUZZER" on CONSULT-II, and perform "LIGHT WARN ALM", "IGN KEY WARN ALM", OR "SEAT BELT WARN TEST" active test.

Does chime sound?

- YES >> Replace the BCM. Refer to [BCS-26, "REMOVAL AND INSTALLATION"](#).
- NO >> Replace the combination meter. Refer to [IP-13, "COMBINATION METER"](#).

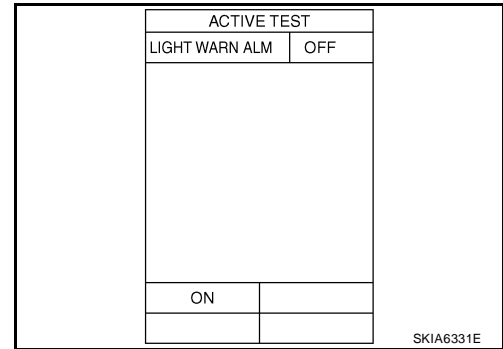

Key Warning Chime and Light Warning Chime Do Not Operate (Seat Belt Warning Chime Does Operate)

EKS00ADU

1. CHECK BCM INPUT SIGNAL

With CONSULT-II

1. Select "BCM" on CONSULT-II.
2. With "DATA MONITOR" of "BUZZER", confirm "DOOR SW-DR" changes with the status of front door LH.

When front door LH is opened : DOOR SW-DR ON

When front door LH is closed : DOOR SW-DR OFF

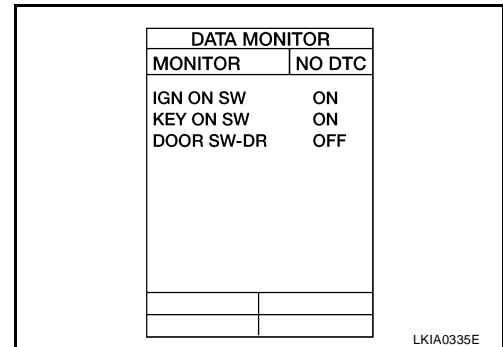

Without CONSULT-II

Check voltage between BCM harness connector M19 terminal 47 and ground.

When front door LH is opened : Approx. 0V

When front door LH is closed : Approx. 5V

OK or NG

- OK >> Replace the BCM. Refer to [BCS-26, "REMOVAL AND INSTALLATION"](#).
- NG >> GO TO 2.

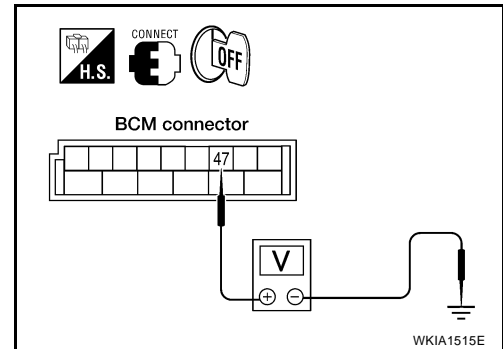

WARNING CHIME

2. CHECK FRONT DOOR SWITCH LH CIRCUIT

1. Turn ignition switch OFF.
2. Disconnect BCM connector M19 and front door switch LH connector B8.
3. Check continuity between BCM harness connector M19 terminal 47 and front door switch LH harness connector B8 terminal 2.

Continuity should exist.

4. Check continuity between BCM harness connector M19 terminal 47 and ground.

Continuity should not exist.

OK or NG

OK >> GO TO 3.

NG >> Repair harness or connector.

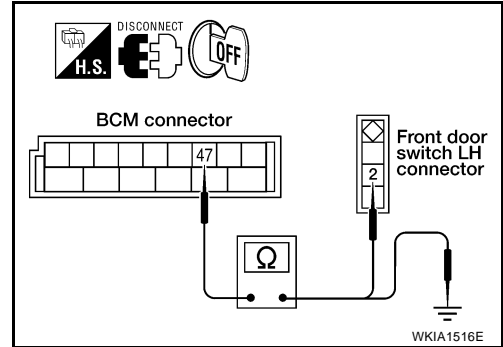

3. CHECK FRONT DOOR SWITCH LH

CREW CAB MODELS

Check continuity between front door switch LH terminal 2 and exposed metal of switch while pushing and releasing switch.

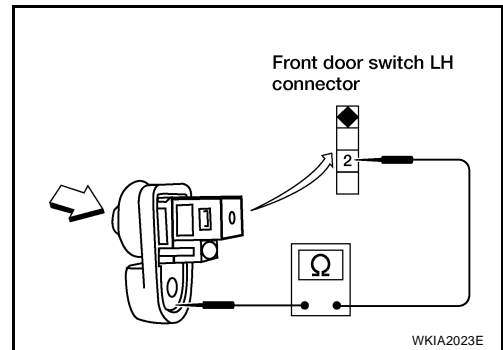

KING CAB MODELS

Check continuity between front door switch LH terminal 2 and terminal 3 of switch while pushing and releasing switch.

When front door switch LH is released : Continuity should exist.

When front door switch LH is pushed : Continuity should not exist.

OK or NG

OK >> Replace the BCM. Refer to [BCS-26, "REMOVAL AND INSTALLATION"](#).

NG >> Replace the front door switch LH.

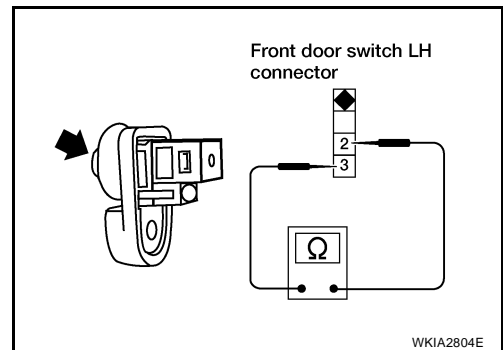

Key Warning Chime Does Not Operate

1. CHECK FUSE

Check if the key switch fuse [No. 19, located in the fuse block (J/B)] is blown. Refer to [DI-40, "Wiring Diagram — CHIME —"](#).

Is the fuse blown?

YES >> Replace the fuse. Be sure to repair the cause of malfunction before installing new fuse.

NO >> GO TO 2.

WARNING CHIME

2. CHECK WARNING CHIME OPERATION

With key removed from the ignition and the front door LH open, turn the lighting switch to 1st or 2nd position.

Does warning chime sound?

YES >> GO TO 3.

NO >> Go to [DI-44, "All Warning Chimes Do Not Operate"](#) or [DI-44, "Key Warning Chime and Light Warning Chime Do Not Operate \(Seat Belt Warning Chime Does Operate\)"](#).

3. CHECK BCM INPUT SIGNAL

① With CONSULT-II

With "DATA MONITOR" of "BUZZER", confirm "KEY ON SW" changes when the key is inserted/removed from the ignition key cylinder.

When key is inserted in ignition key cylinder : KEY ON SW ON

When key is removed from ignition key cylinder : KEY ON SW OFF

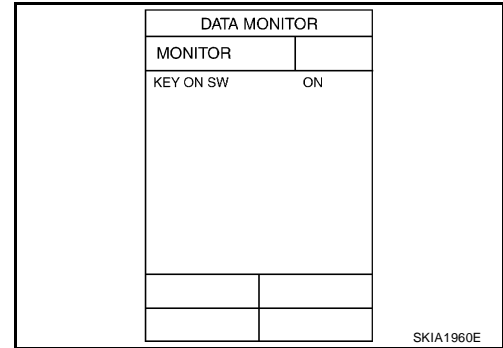

② Without CONSULT-II

Check voltage between BCM harness connector M18 terminal 37 and ground.

When key is inserted in ignition key cylinder : Approx. 12V

When key is removed from ignition key cylinder : Approx. 0V

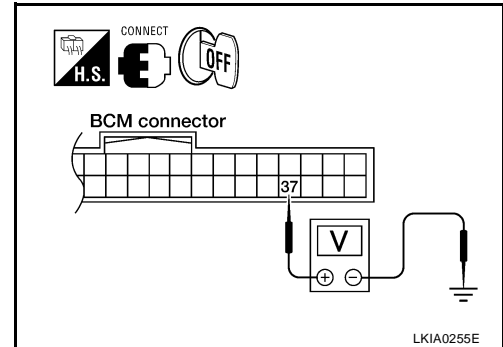

OK or NG

OK >> Replace the BCM. Refer to [BCS-26, "REMOVAL AND INSTALLATION"](#).

NG >> GO TO 4.

4. CHECK KEY SWITCH

1. Turn ignition switch OFF.
2. Disconnect key switch and key lock solenoid connector (floor shift) or key switch connector (column shift).
3. Check continuity between key switch and key lock solenoid (floor shift) or key switch (column shift) terminals 3 and 4.

When key is inserted in ignition key cylinder : Continuity should exist.

When key is removed from ignition key cylinder : Continuity should not exist.

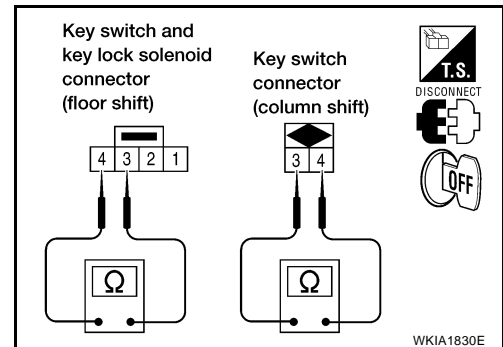

OK or NG

OK >> GO TO 5.

NG >> Replace the key switch and key lock solenoid (floor shift) or key switch (column shift).

WARNING CHIME

5. CHECK KEY SWITCH CIRCUIT

1. Disconnect BCM connector M18.
2. Check continuity between BCM harness connector M18 terminal 37 and key switch and key lock solenoid harness connector M27 (floor shift) or key switch harness connector M80 (column shift) terminal 4.

Continuity should exist.

3. Check continuity between BCM harness connector M18 terminal 37 and ground.

Continuity should not exist.

OK or NG

- OK >> GO TO 6.
 NG >> Repair harness or connector.

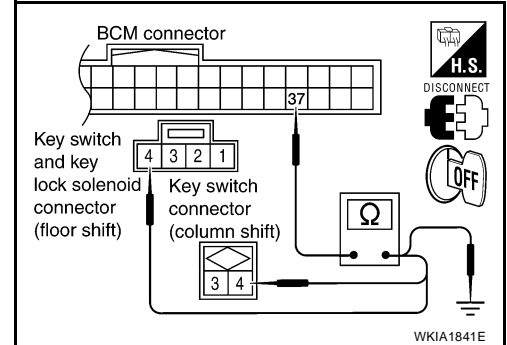

6. CHECK KEY SWITCH POWER SUPPLY CIRCUIT

Check voltage between key switch and key lock solenoid harness connector M27 (floor shift) or key switch harness connector M80 (column shift) terminal 3 and ground.

Battery voltage should exist.

OK or NG

- OK >> Replace the BCM. Refer to [BCS-26, "REMOVAL AND INSTALLATION"](#).
- NG >> Check harness for open or short between fuse and key switch and key lock solenoid connector (floor shift) or key switch connector (column shift).

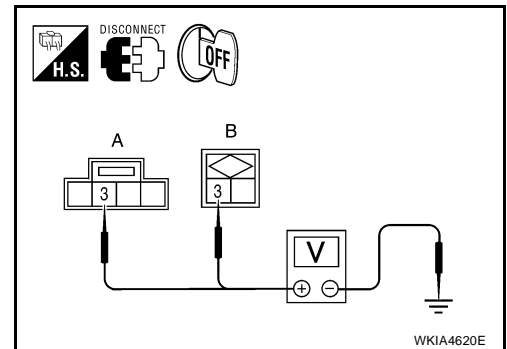

Light Warning Chime Does Not Operate

1. CHECK WARNING CHIME OPERATION

Check key warning chime and seat belt warning chime functions.

Do key warning chime and seat belt warning chime sound?

- YES >> GO TO 2.
 NO >> Go to [DI-44, "All Warning Chimes Do Not Operate"](#).

2. CHECK BCM INPUT SIGNAL

With CONSULT-II

1. Select "BCM".
2. With "DATA MONITOR" of "BUZZER", confirm "LIGHT SW 1ST" status changes when the lighting switch is moved from ON (1st position) to OFF.

Lighting switch ON (1st position) : LIGHT SW 1ST ON

Lighting switch OFF : LIGHT SW 1ST OFF

Without CONSULT-II

Check combination switch. Refer to [LT-76, "Combination Switch Reading Function"](#).

OK or NG

- OK >> Replace the BCM. Refer to [BCS-26, "REMOVAL AND INSTALLATION"](#).
- NG >> Check lighting switch. Refer to [LT-76, "Combination Switch Reading Function"](#).

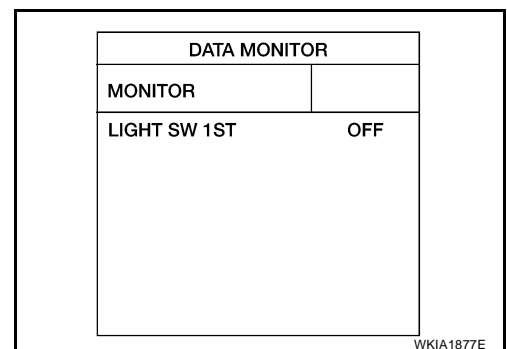

WARNING CHIME

EKS00ADX

Seat Belt Warning Chime Does Not Operate

1. CHECK WARNING CHIME OPERATION

1. With key removed from the ignition and the front door LH open, turn the lighting switch to 1st or 2nd position.
2. Return lighting switch to OFF position, and insert key into ignition.

Does warning chime sound for both steps?

YES >> GO TO 2.

NO >> Go to [DI-44, "All Warning Chimes Do Not Operate"](#) .

2. CHECK SEAT BELT WARNING LAMP OPERATION

Turn ignition switch ON. Buckle and unbuckle the driver seat belt while watching seat belt warning lamp.

When seat belt is fastened : Warning lamp OFF

When seat belt is unfastened : Warning lamp ON

OK or NG

OK >> Replace the BCM. Refer to [BCS-26, "REMOVAL AND INSTALLATION"](#) .

NG >> GO TO 3.

3. CHECK COMBINATION METER INPUT SIGNAL

1. Turn ignition switch ON.
2. Check voltage between combination meter harness connector M24 terminal 27 and ground.

When seat belt is fastened : Approx. 12V

When seat belt is unfastened : Approx. 0V

OK or NG

OK >> Replace the combination meter. Refer to [IP-13, "COMBINATION METER"](#) .

NG >> GO TO 4.

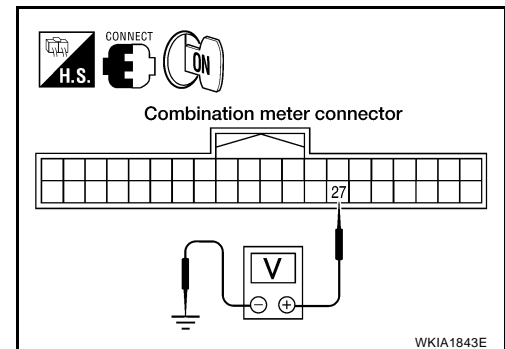

4. CHECK SEAT BELT BUCKLE SWITCH

1. Turn ignition switch OFF.
2. Disconnect seat belt buckle switch LH connector.
3. Check continuity between seat belt buckle switch LH terminals 1 and 2.

When seat belt is fastened : Continuity should not exist.

When seat belt is unfastened : Continuity should exist.

OK or NG

OK >> GO TO 5.

NG >> Replace the seat belt buckle switch LH.

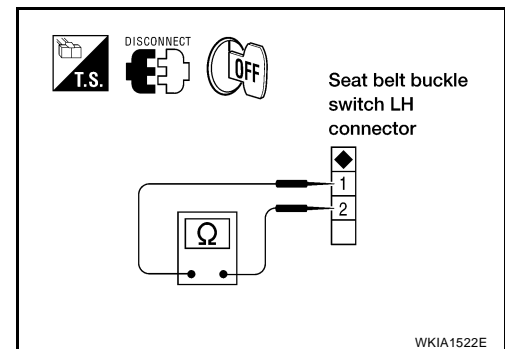

WARNING CHIME

5. CHECK SEAT BELT BUCKLE SWITCH CIRCUIT

1. Disconnect combination meter connector.
2. Check continuity between combination meter harness connector M24 terminal 27 and seat belt buckle switch LH harness connector B12 terminal 1.

Continuity should exist.

3. Check continuity between combination meter harness connector M24 terminal 27 and ground.

Continuity should not exist.

OK or NG

OK >> GO TO 6.

NG >> Repair harness or connector.

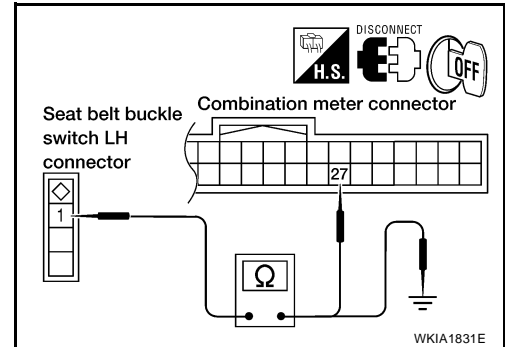

6. CHECK SEAT BELT BUCKLE SWITCH GROUND CIRCUIT

Check continuity between seat belt buckle switch LH harness connector B12 terminal 2 and ground.

Continuity should exist.

OK or NG

OK >> Replace combination meter. Refer to [IP-13, "COMBINATION METER"](#).

NG >> Repair harness or connector.

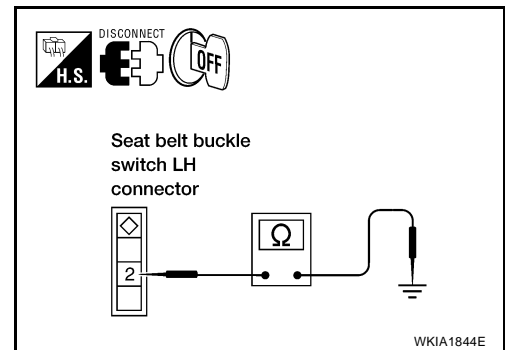

A
B
C
D
E
F
G
H
I
J
DI
L
M

REAR SONAR SYSTEM

REAR SONAR SYSTEM

PFP:28532

Component Parts and Harness Connector Location

EKS00ADY

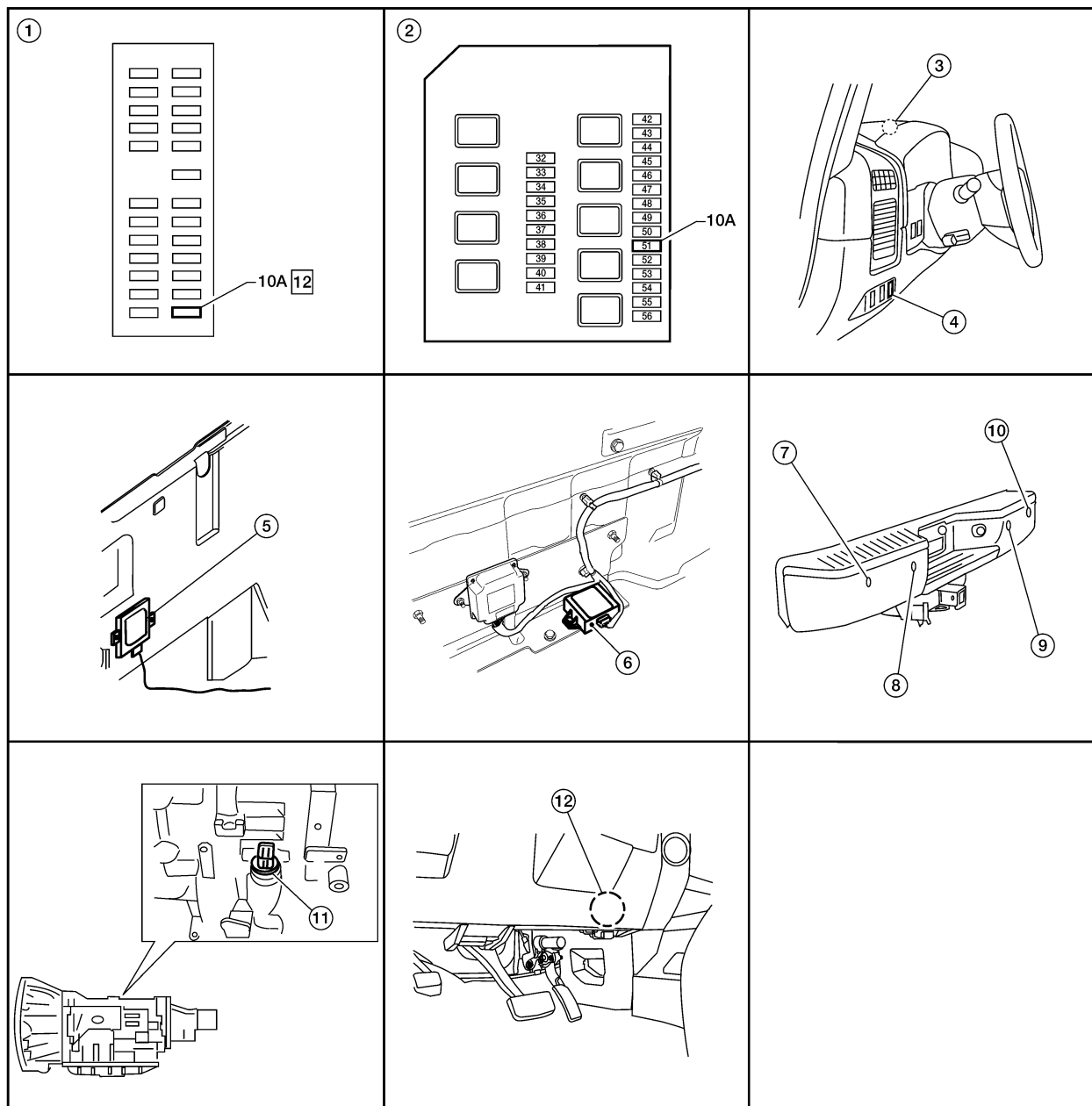

- | | | |
|--------------------------------------|--------------------------------------|--------------------------------------|
| 1. Fuse block (J/B) | 2. IPDM E/R E119 | 3. Sonar buzzer M117 |
| 4. Rear sonar system OFF switch M116 | 5. Sonar control unit B56 (crew cab) | 6. Sonar control unit B56 (king cab) |
| | (view of rear cab) | (view of rear cab) |
| 7. Rear sonar sensor LH outer C102 | 8. Rear sonar sensor LH inner C103 | 9. Rear sonar sensor RH inner C104 |
| 10. Rear sonar sensor RH outer C105 | 11. A/T assembly F9 | 12. Back-up lamp relay M73 |

WKIA4621E

REAR SONAR SYSTEM

EKS00ADZ

System Description

FUNCTION

With the ignition switch in the ON or START position, power is supplied

- through 10A fuse [No. 12 , located in the fuse block (J/B)]
- to sonar control unit terminal 8,
- through 10A fuse (No. 51, located in the IPDM E/R)
- to back-up lamp relay terminals 1 and 3.

Ground is supplied

- to sonar control unit terminal 6
- through body grounds B7 and B19.

With the ignition switch in the ON or START position, and the transmission gear selector lever in the R position, power is supplied

- to sonar control unit terminal 5
- from back-up lamp relay terminal 5.

With power and ground supplied, transmission gear selector lever in R position, and the rear sonar system OFF switch ON, the rear sonar system will detect obstacles within 1.8 m (5.9 ft.) of the rear sonar sensors. The vehicle operator is notified of obstacles by varied rate of tone from the sonar buzzer depending on distance of obstacle being sensed.

REAR SONAR SYSTEM OFF SWITCH

With power and ground supplied to the sonar control unit, transmission gear selector lever in R position, the sonar system can be disabled and the sonar buzzer silenced by momentarily pressing the rear sonar system OFF switch. The rear sonar system OFF indicator lamp will be illuminated in the rear sonar system OFF switch.

To disable the rear sonar system, ground is supplied

- to sonar control unit terminal 13
- through rear sonar system OFF switch terminal 1
- through rear sonar system OFF switch terminal 2
- from body grounds M57, M61, and M79.

To light the rear sonar system OFF indicator, power is supplied

- from sonar control unit terminal 4
- to the rear sonar system OFF switch terminal 5.

Ground is supplied

- to the rear sonar system OFF switch terminal 6
- from body grounds M57, M61, and M79.

The rear sonar system and buzzer will be disabled and the rear sonar system OFF indicator will be illuminated until the ignition switch is turned OFF. When the ignition is turned ON, the rear sonar system will be enabled. Depressing the rear sonar system OFF switch momentarily will enable the rear sonar system also. Enabling the rear sonar system will cause the rear sonar system OFF indicator to go out.

SONAR BUZZER

With the power supplied to the sonar control unit and the transmission gear selector lever in R position, a stationary object that is at least 7.0 cm (2.8 in.) wide and 1.0 m (39.0 in.) tall and that is closer than 1.8 meters (5.9 ft.) will be detected by the rear sonar sensors, causing the sonar buzzer to sound a tone. As the vehicle moves closer to the object, the rate of the tone will increase. When the object is less than 25.0 cm (10 in.) from the rear bumper, the tone will sound continuously.

Power is supplied

- from sonar control unit terminal 7
- to sonar buzzer terminal 1.

Ground is supplied

- to sonar buzzer terminal 2
- from sonar control unit terminal 3.

A
B
C
D
E
F
G
H
I
J
L
M

DI

REAR SONAR SYSTEM

REAR SONAR SENSOR

With power and ground supplied to the rear sonar sensors, the sonar sensors transmit a 38.4 kHz ultrasonic signal. This signal is reflected back to the sensor by objects large enough and close enough to be detected. The rear sonar sensors measure the time from the transmitted signal to the time the signal is reflected back and sends this information to the sonar control unit.

Power is supplied

- from sonar control unit terminal 16
- to each rear sonar sensor terminal 1.

Ground is supplied

- to each rear sonar sensor terminal 3
- from sonar control unit terminal 15.

Signal is supplied

- from each rear sonar sensor terminal 2
- to sonar control unit terminals 9, 10, 11 and 12.

REAR SONAR SYSTEM

Wiring Diagram — SONAR —

EKS00AEO

DI-SONAR-01

REFER TO "PG-POWER".

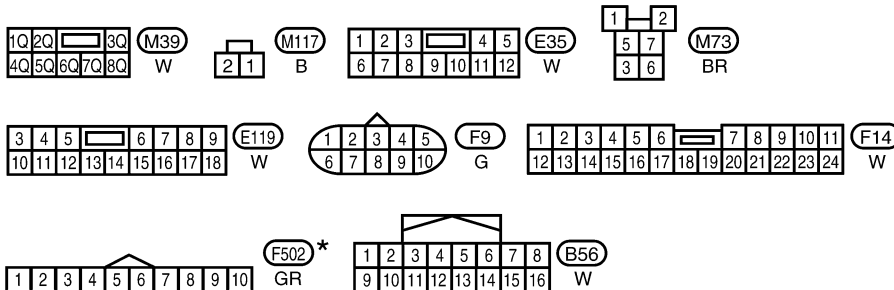
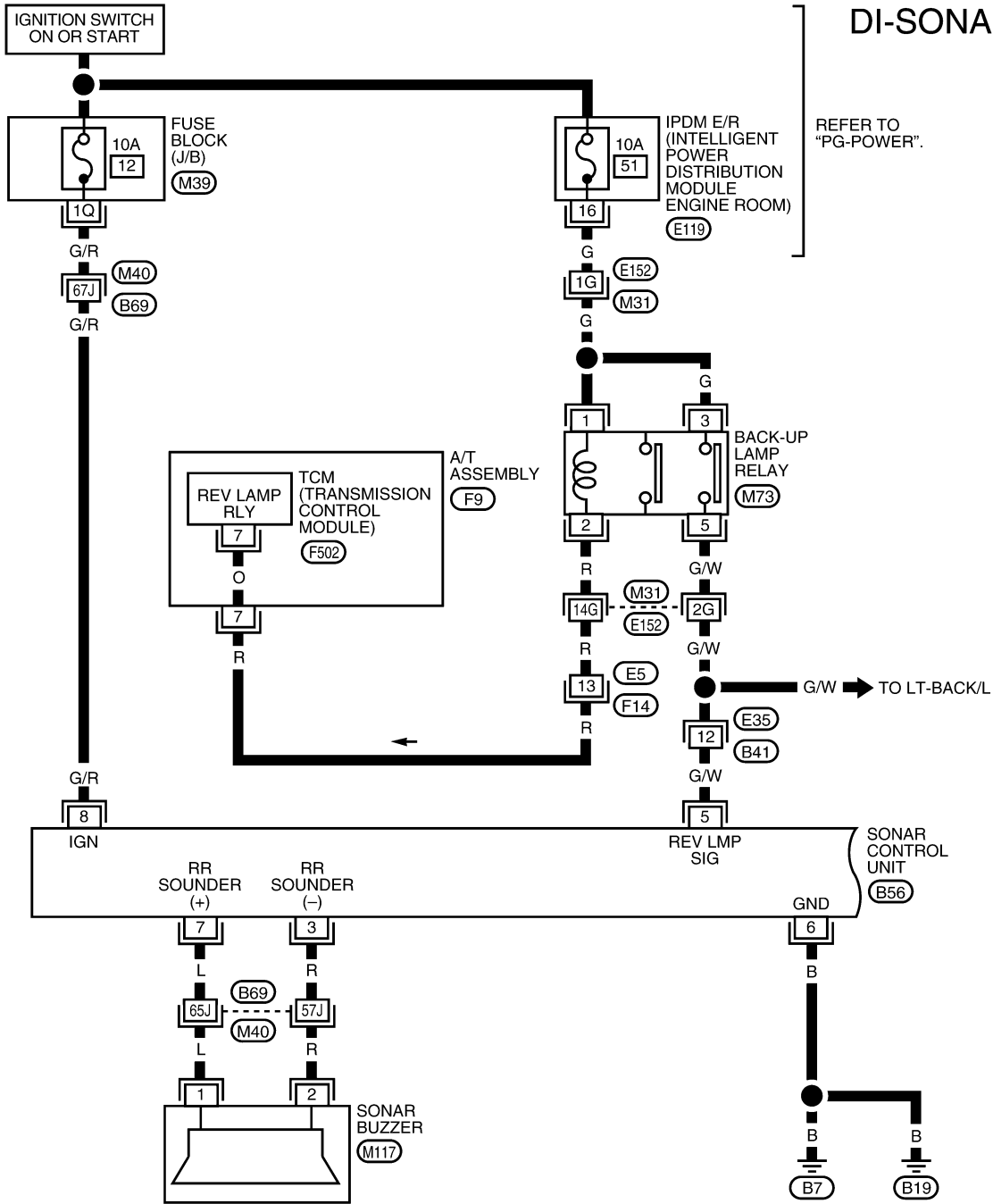

*: THIS CONNECTOR IS NOT SHOWN IN "HARNESS LAYOUT" OF PG SECTION.

REFER TO THE FOLLOWING.
 (M31), (M40) - SUPER
 MULTIPLE JUNCTION (SMJ)

WKWA3721E

REAR SONAR SYSTEM

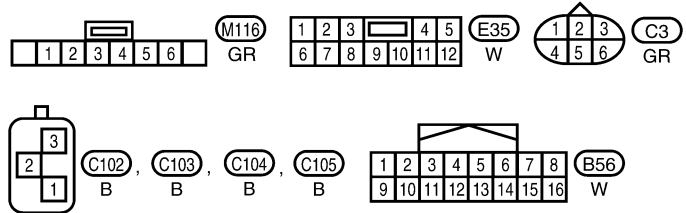
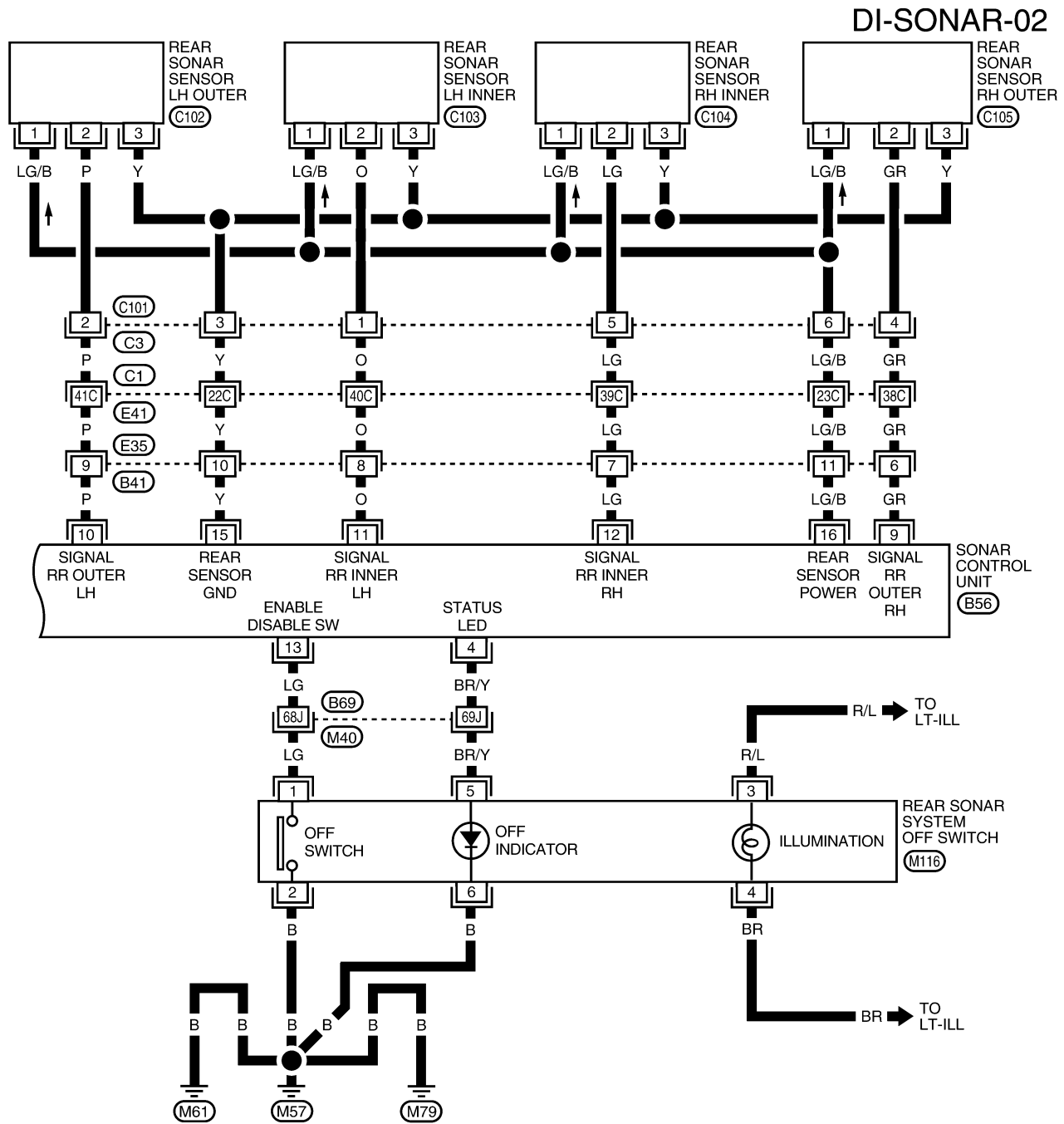

REFER TO THE FOLLOWING.
 (M40), (C1) - SUPER MULTIPLE
 JUNCTION (SMJ)

WKWA3722E

REAR SONAR SYSTEM

Sonar Control Unit Harness Connector Terminal Layout

EKS00J12

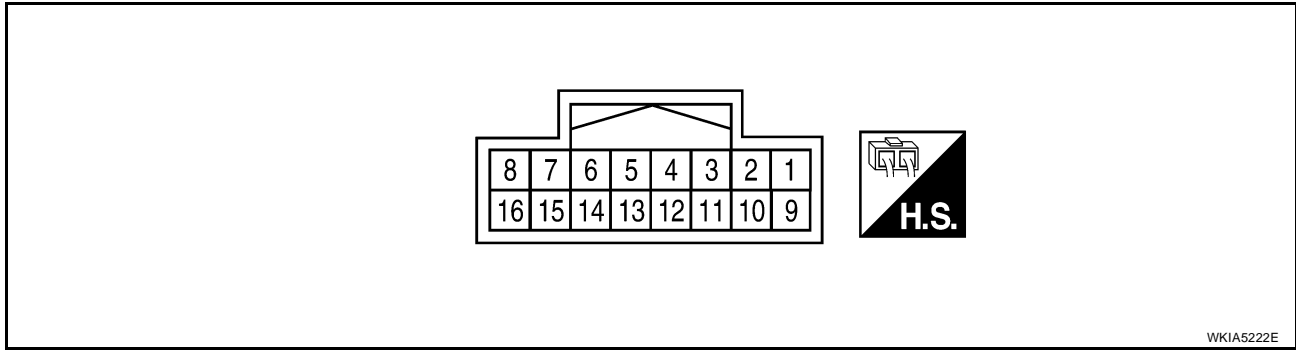

Terminals and Reference Values for Sonar Control Unit

EKS00AE1

Terminal (color)	Item	Condition		Reference value (V) (Approx.)	
		Ignition switch	Operation		
3 (R)	Sonar buzzer return	ON	—	0 - 12 (variable)	
4 (BR/Y)	Rear sonar system OFF indicator output	ON	Rear sonar system OFF switch	ON	0
				OFF	Battery voltage
5 (G/W)	Reverse signal	ON	Transmission gear selector lever	R position	Battery voltage
			Transmission gear selector lever	Not R position	0
6 (B)	Sonar control unit ground	—	—	0	
7 (L)	Sonar buzzer drive signal	ON	—	Battery voltage	
8 (G/R)	Sonar control unit power	ON	—	Battery voltage	
9 (GR)	Rear sonar sensor signal - RH outer	ON	<ul style="list-style-type: none"> ● Rear sonar system OFF switch ON ● Transmission gear selector lever in R position ● Distant or no obstacles 	Battery voltage	
10 (P)	Rear sonar sensor signal - LH outer	ON	<ul style="list-style-type: none"> ● Rear sonar system OFF switch ON ● Transmission gear selector lever in R position ● Distant or no obstacles 	Battery voltage	
11 (O)	Rear sonar sensor signal - LH inner	ON	<ul style="list-style-type: none"> ● Rear sonar system OFF switch ON ● Transmission gear selector lever in R position ● Distant or no obstacles 	Battery voltage	
12 (LG)	Rear sonar sensor signal - RH inner	ON	<ul style="list-style-type: none"> ● Rear sonar system OFF switch ON ● Transmission gear selector lever in R position ● Distant or no obstacles 	Battery voltage	
13 (LG)	Rear sonar system OFF switch signal	ON	Rear sonar system OFF switch	ON	0
				OFF	Battery voltage
15 (Y)	Rear sonar sensor ground	ON	—	0	
16 (LG/B)	Rear sonar sensor power	ON	Ignition switch ON	Battery voltage	

REAR SONAR SYSTEM

EKS00AE2

How to Proceed With Trouble Diagnosis

1. Confirm the symptom or customer complaint.
2. Understand operation description and function description. Refer to [DI-51, "System Description"](#) .
3. Perform pre-diagnosis inspection. Refer to [DI-56, "Pre-diagnosis Inspection"](#) .
4. Perform self-diagnosis. Refer to [DI-56, "Self-diagnosis Function"](#) .
5. Perform the preliminary check. Refer to [DI-58, "Preliminary Check"](#) .
6. Check symptom and repair or replace the cause of malfunction. Refer to [DI-59, "Symptom Chart"](#) .
7. Clear fault codes. Refer to [DI-57, "IDLING OR CLEARING FAULT CODES MODE"](#) .
8. Does the rear sonar system operate properly? If so, go to 9. If not, go to 3.
9. Inspection End.

Pre-diagnosis Inspection SENSOR STATUS CHECK

EKS00AE3

- Check that the rear sonar sensors are properly aligned (bumper is not misaligned, no deformation in sensor mounting area).
- Check that snow, mud, or other foreign objects are not adhering to the rear sonar sensors.
- Check that there is no deformation, scratches, or other damage to the rear sonar sensors.
- Check that water has not accumulated in the rear sonar sensors.

CAUTION:

Use water, cotton swab, or other soft material for cleaning the sensors.

1. Check that there are no obstacles within each rear sonar sensor's detection range.

	Detection range
Rear sonar sensors	Approx. 1.8 m (5.9 ft.) maximum

2. Check that there are no nearby ultrasound sources (such as the sounds of vehicle horns, motorcycle engines, or truck air brakes).
3. Check that the vehicle is on a level surface.

Self-diagnosis Function

EKS00AE4

There are four modes of self-diagnosis; entering diagnostics, requesting number of fault codes, requesting fault codes, and idling or clearing fault codes. These steps must be followed in order. Self-diagnosis can be manually exited by turning the ignition OFF, or selecting reverse gear. Self-diagnosis will exit unless a fault code request occurs before a message is repeated five times without acknowledgement.

ENTERING DIAGNOSTICS MODE

1. Turn ignition switch ON. Rear sonar system OFF switch indicator lamp illuminates for three seconds and then turns off.
2. Immediately push rear sonar system OFF switch ten times within five seconds.
3. The sonar buzzer will sound once and the rear sonar system OFF indicator will flash once.

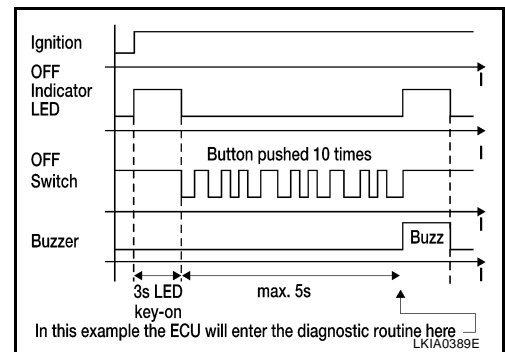

REAR SONAR SYSTEM

REQUESTING NUMBER OF FAULT CODES MODE

1. While in diagnostic mode, push rear sonar system OFF switch once.
2. The sonar buzzer will sound once.
3. Rear sonar system OFF indicator will flash once and sonar buzzer will sound once for each fault code detected.
4. There will be a four second pause.
5. The number of fault codes will repeat five times then pause.

NOTE:

Self-diagnosis will exit unless requesting fault codes occurs before five repeats ends.

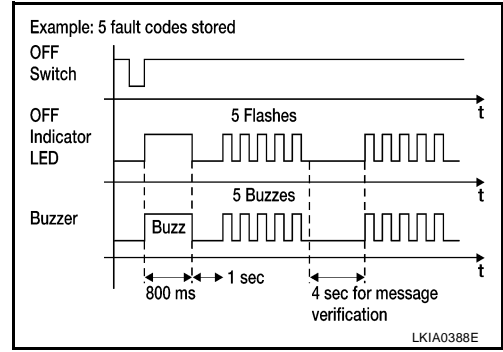

REQUESTING FAULT CODES MODE

1. While in "requesting number of fault codes" mode, push rear sonar system OFF switch once.
2. The sonar buzzer will sound once.
3. Rear sonar system OFF indicator will flash and sonar buzzer will sound the first digit of the fault code followed by a one second pause.
4. Rear sonar system OFF indicator will flash and sonar buzzer will sound the second digit of the fault code followed by a four second pause.
5. The fault codes will repeat five times then pause.

NOTE:

Requesting fault codes will exit unless the fault code is acknowledged before five repeats ends.

The fault code is acknowledged by pushing the rear sonar system OFF switch once (the sonar buzzer may sound). When all fault codes have been indicated, idle mode will be entered. See the following table for fault code identification.

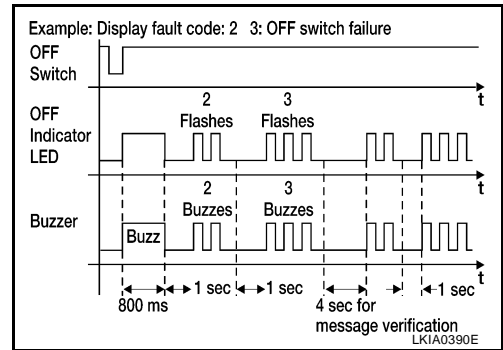

Fault Code	Malfunction	Page Reference
1 1	Rear sonar sensor LH outer	Check harness for open or short. If NG repair or replace harness. If OK replace sensor. Refer to DI-61, "REAR SONAR SENSORS" .
1 2	Rear sonar sensor LH inner	
1 3	Rear sonar sensor RH inner	
1 4	Rear sonar sensor RH outer	
2 1	Sonar buzzer	DI-60, "SONAR BUZZER"
2 2	Rear sonar system OFF indicator	DI-61, "REAR SONAR SYSTEM OFF INDICATOR"
2 3	Rear sonar system OFF switch	DI-60, "REAR SONAR SYSTEM OFF SWITCH"
2 4	Sonar control unit	Replace sonar control unit. Refer to DI-61, "SONAR CONTROL UNIT" .

IDLING OR CLEARING FAULT CODES MODE

NOTE:

While in idle mode, self-diagnosis will automatically exit if no activity occurs for thirty seconds.

REAR SONAR SYSTEM

1. Push and hold rear sonar system OFF switch for three seconds to reset time-out counter.
2. Push and hold rear sonar system OFF switch for three seconds to clear codes.

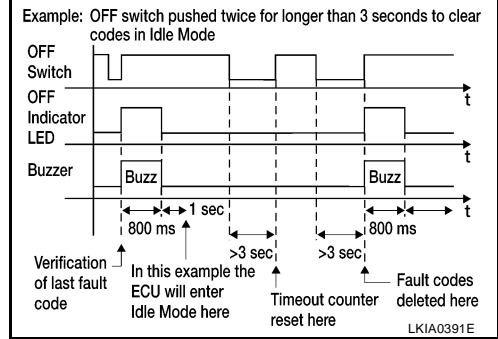

EKS00AE5

Preliminary Check INSPECTION FOR POWER SUPPLY AND GROUND CIRCUIT

1. CHECK FUSES

Check for blown rear sonar system fuses.

Unit	Power Source	Fuse
Sonar control unit	ON or START	12

Refer to [DI-53, "Wiring Diagram — SONAR —"](#).

OK or NG

OK >> GO TO 2.

NG >> If fuse is blown, be sure to eliminate cause of problem before installing new fuse. Refer to [PG-4, "POWER SUPPLY ROUTING CIRCUIT"](#).

2. CHECK POWER SUPPLY CIRCUIT

1. Disconnect sonar control unit connector.
2. Check voltage between sonar control unit connector B56 terminal 8 and ground.

Terminals		Ignition switch position	
(+)		(-)	
Connector	Terminal	ON or START	
B56	8	Ground	Battery voltage

OK or NG

OK >> GO TO 3.

NG >> Check harness for open between sonar control unit and fuse.

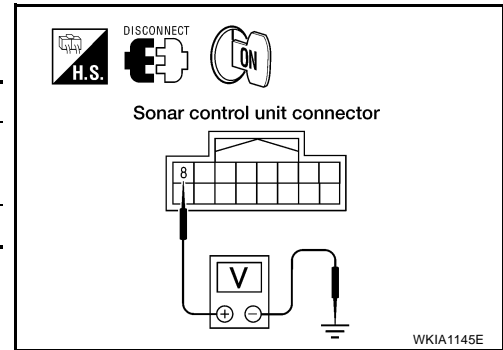

3. CHECK GROUND CIRCUIT

1. Turn ignition switch OFF.
2. Check continuity between sonar control unit B56 terminal 6 and ground.

Terminals		Continuity	
(+)			
Connector	Terminal	(-)	
B56	6	Ground	Yes

OK or NG

OK >> Inspection End.

NG >> Check harness ground circuit.

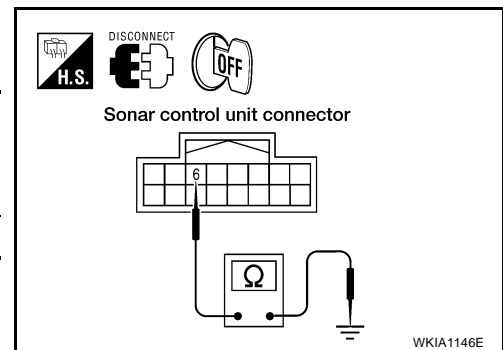

REAR SONAR SYSTEM

EKS00AE6

Symptom Chart

Symptom	Repair order
When the rear sonar system OFF switch is OFF, the indicator lamp does not light and the buzzer does not sound.	<ol style="list-style-type: none"> 1. Check rear sonar system OFF switch for malfunction. Refer to DI-60, "REAR SONAR SYSTEM OFF SWITCH" . 2. Check rear sonar system OFF switch ground circuit. 3. Check harness and connections between rear sonar system OFF switch and sonar control unit. 4. Replace sonar control unit. Refer to DI-61, "SONAR CONTROL UNIT" .
When the rear sonar system OFF switch is OFF, the indicator lamp does not light but buzzer sounds.	<ol style="list-style-type: none"> 1. Check rear sonar system OFF indicator for malfunction. Refer to DI-61, "REAR SONAR SYSTEM OFF INDICATOR" . 2. Check harness and connections between rear sonar system OFF indicator and sonar control unit. 3. Replace sonar control unit. Refer to DI-61, "SONAR CONTROL UNIT" .
When the rear sonar system OFF switch is OFF, the sonar buzzer does not sound but indicator lamp illuminates.	<ol style="list-style-type: none"> 1. Check sonar buzzer. Refer to DI-60, "SONAR BUZZER" . 2. Check harness and connections between sonar buzzer and sonar control unit. 3. Replace sonar control unit. Refer to DI-61, "SONAR CONTROL UNIT" .
When rear sonar system OFF switch is ON, the rear sonar system OFF indicator lamp lights up and the sonar buzzer sounds intermittently (for about 4 seconds).	<ol style="list-style-type: none"> 1. Check harness between rear sonar sensors and sonar control unit for an open condition. 2. Check rear sonar sensors for malfunction. 3. Replace sonar control unit. Refer to DI-61, "SONAR CONTROL UNIT" .
The rear sonar system operates with the rear sonar system OFF switch OFF.	<ol style="list-style-type: none"> 1. Check rear sonar system OFF switch for malfunction. Refer to DI-60, "REAR SONAR SYSTEM OFF SWITCH" . 2. Check rear sonar system OFF switch ground circuit. 3. Check harness and connections between rear sonar system OFF switch and sonar control unit. 4. Replace sonar control unit. Refer to DI-61, "SONAR CONTROL UNIT" .
When the transmission gear selector lever is in the R position and the rear sonar system OFF switch is OFF, the sonar system does not operate.	<ol style="list-style-type: none"> 1. Check for PNP switch failure. Refer to AT-89, "SELF-DIAGNOSTIC RESULT MODE" . 2. Check harness and connections between sonar control unit and PNP/reverse lamp circuits. 3. Replace sonar control unit. Refer to DI-61, "SONAR CONTROL UNIT" .

A
B
C
D
E
F
G
H
I
J
DI
L
M

REAR SONAR SYSTEM

Symptom	Repair order
<p>When the rear sonar system OFF switch is OFF, the indicator lamp lights up and buzzer sounds although there is no obstacle within the detection range.</p>	<ol style="list-style-type: none"> 1. Check for adhesion of snow, mud, or other foreign objects to rear sonar sensors; dew condensation; etc. Refer to DI-56, "Pre-diagnosis Inspection" . 2. Check that the rear sonar sensors are properly aligned (bumper is not misaligned, no deformation in sensor mounting area). 3. Check harness and connections between rear sonar sensors and sonar control unit. 4. Check rear sonar sensors for malfunction. 5. Replace sonar control unit. Refer to DI-61, "SONAR CONTROL UNIT" .
<p>The rear sonar sensors do not operate according to the distance between each sensor and the obstacle. (There is a large error in the obstacle detection distance.)</p>	<ol style="list-style-type: none"> 1. Check rear sonar sensors for malfunction. 2. Replace sonar control unit. Refer to DI-61, "SONAR CONTROL UNIT" . 3. Check for adhesion of snow, mud, or other foreign objects to rear sonar sensors; dew condensation; etc. Refer to DI-56, "Pre-diagnosis Inspection" . 4. Check that the rear sonar sensors are properly aligned (bumper is not misaligned, no deformation in sensor mounting area).

Component Inspection SONAR BUZZER

EKS00AE7

1. Disconnect the sonar buzzer connector.
2. Check continuity between buzzer connector M117 terminal 1 and terminal 2

1 - 2 : Continuity should exist

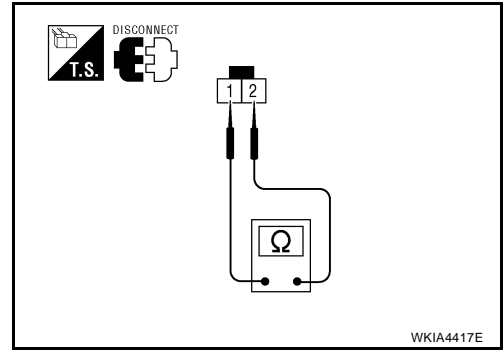

REAR SONAR SYSTEM OFF SWITCH

Disconnect the rear sonar system OFF switch M116. Check the continuity between following terminals.

Rear sonar system OFF switch	Terminal to be inspected	Continuity
Depressed	1 - 2	Yes
Released		No

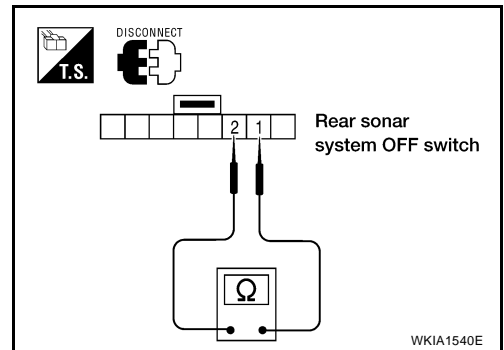

REAR SONAR SYSTEM

REAR SONAR SYSTEM OFF INDICATOR

Disconnect the rear sonar system OFF switch connector M116, and apply battery voltage (approx. 12V) to terminal 5. Check the rear sonar system OFF indicator operation when terminal 6 is connected to battery ground.

	Terminal to be inspected	Condition	Operation
Rear sonar system OFF switch	5	Approx. 12V	Rear sonar system OFF indicator lights
	6	Ground	

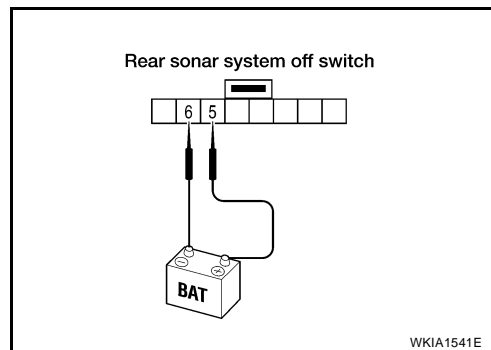

Removal and Installation REAR SONAR SENSORS

Refer to [EI-18, "REAR BUMPER"](#).

SONAR CONTROL UNIT

Removal

1. Remove the rear panel. Refer to [EI-39, "REAR"](#).
2. For king cab models only, pull up the carpet to gain access to the sonar control unit.
3. Disconnect the sonar control unit connector.
4. Remove the sonar control unit bolts and remove sonar control unit.

Installation

Installation is in the reverse order of removal.

A
B
C
D
E
F
G
H
I
J
DI
L
M

REAR SONAR SYSTEM
