

SECTION EI
EXTERIOR & INTERIOR

A
B
C

CONTENTS

<p>PRECAUTIONS 3</p> <p>Service Notice 3</p> <p>Precautions for Supplemental Restraint System (SRS) "AIR BAG" and "SEAT BELT PRE-TENSIONER" 3</p> <p>PREPARATION 4</p> <p>Special Service Tools 4</p> <p>Commercial Service Tools 4</p> <p>SQUEAK AND RATTLE TROUBLE DIAGNOSES..... 5</p> <p>Work Flow 5</p> <p style="padding-left: 20px;">CUSTOMER INTERVIEW 5</p> <p style="padding-left: 20px;">DUPLICATE THE NOISE AND TEST DRIVE 6</p> <p style="padding-left: 20px;">CHECK RELATED SERVICE BULLETINS 6</p> <p style="padding-left: 20px;">LOCATE THE NOISE AND IDENTIFY THE ROOT CAUSE 6</p> <p style="padding-left: 20px;">REPAIR THE CAUSE 6</p> <p style="padding-left: 20px;">CONFIRM THE REPAIR 7</p> <p>Generic Squeak and Rattle Troubleshooting 7</p> <p style="padding-left: 20px;">INSTRUMENT PANEL 7</p> <p style="padding-left: 20px;">CENTER CONSOLE 7</p> <p style="padding-left: 20px;">DOORS 7</p> <p style="padding-left: 20px;">TRUNK 8</p> <p style="padding-left: 20px;">SUNROOF/HEADLINING 8</p> <p style="padding-left: 20px;">OVERHEAD CONSOLE (FRONT AND REAR)..... 8</p> <p style="padding-left: 20px;">SEATS 8</p> <p style="padding-left: 20px;">UNDERHOOD 8</p> <p>Diagnostic Worksheet 9</p> <p>CLIP AND FASTENER11</p> <p>Clip and Fastener11</p> <p>FRONT BUMPER 14</p> <p>Removal and Installation 14</p> <p style="padding-left: 20px;">STEEL BUMPER 14</p> <p style="padding-left: 20px;">PLASTIC BUMPER 16</p> <p>REAR BUMPER 18</p> <p>Removal and Installation 18</p> <p style="padding-left: 20px;">REMOVAL 18</p> <p style="padding-left: 20px;">INSTALLATION 19</p>	<p>FRONT GRILLE 20</p> <p>Removal and Installation 20</p> <p style="padding-left: 20px;">REMOVAL 20</p> <p style="padding-left: 20px;">INSTALLATION 20</p> <p>COWL TOP 21</p> <p>Removal and Installation 21</p> <p style="padding-left: 20px;">REMOVAL 21</p> <p style="padding-left: 20px;">INSTALLATION 22</p> <p>FRONT FENDER 23</p> <p>Removal and Installation 23</p> <p style="padding-left: 20px;">REMOVAL 23</p> <p style="padding-left: 20px;">INSTALLATION 23</p> <p>FENDER PROTECTOR 24</p> <p>Removal and Installation 24</p> <p style="padding-left: 20px;">REMOVAL 24</p> <p style="padding-left: 20px;">INSTALLATION 24</p> <p>RUNNING BOARDS 25</p> <p>Removal and Installation 25</p> <p style="padding-left: 20px;">REMOVAL 26</p> <p style="padding-left: 20px;">INSTALLATION 26</p> <p>MUDGUARD 27</p> <p>Removal and Installation 27</p> <p>DOOR OUTSIDE MOLDING 28</p> <p>Removal and Installation 28</p> <p style="padding-left: 20px;">FRONT DOOR OUTSIDE MOLDING 29</p> <p style="padding-left: 20px;">REAR DOOR OUTSIDE MOLDING 29</p> <p>SIDE GUARD MOLDING 30</p> <p>Removal and Installation 30</p> <p style="padding-left: 20px;">REMOVAL 31</p> <p style="padding-left: 20px;">INSTALLATION 31</p> <p>DOOR FINISHER 32</p> <p>Removal and Installation 32</p> <p style="padding-left: 20px;">FRONT DOOR 32</p> <p style="padding-left: 20px;">REAR DOOR - CREW CAB 33</p> <p style="padding-left: 20px;">REAR DOOR - KING CAB 35</p>
--	---

D
E
F
G
H
EI
J
K
L
M

BODY SIDE TRIM	36	HEADLINING	43
Removal and Installation	36	Removal and Installation	43
KING CAB	36	REMOVAL	47
CREW CAB	37	INSTALLATION	47
LOWER DASH SIDE FINISHER	38	BED RAILS AND TRIM	48
CENTER PILLAR LOWER FINISHER	38	Removal and Installation	48
CENTER PILLAR UPPER FINISHER	38	REMOVAL	49
FRONT PILLAR FINISHER	38	INSTALLATION	49
KICKING PLATES	38	TAIL GATE FINISHER	50
DOOR PARTING SEALS	38	Removal and Installation	50
REAR	39	REMOVAL	50
FLOOR TRIM	41	INSTALLATION	50
Removal and Installation	41	STORAGE BOX	51
REMOVAL	41	Removal and Installation	51
INSTALLATION	42	REMOVAL	51
		INSTALLATION	52

PRECAUTIONS

PRECAUTIONS

PFP:00001

Service Notice

EIS004E7

- When removing or installing various parts, place a cloth or padding on the vehicle body to prevent scratches.
- Handle trim, molding, instruments, grille, etc. carefully during removing or installing. Be careful not to soil or damage them.
- Apply sealing compound where necessary when installing parts.
- When applying sealing compound, be careful that the sealing compound does not protrude from parts.
- When replacing any metal parts (for example body outer panel, members, etc.), be sure to take rust prevention measures.

Precautions for Supplemental Restraint System (SRS) “AIR BAG” and “SEAT BELT PRE-TENSIONER”

EIS004E8

The Supplemental Restraint System such as “AIR BAG” and “SEAT BELT PRE-TENSIONER”, used along with a front seat belt, helps to reduce the risk or severity of injury to the driver and front passenger for certain types of collision. This system includes seat belt switch inputs and dual stage front air bag modules. The SRS system uses the seat belt switches to determine the front air bag deployment, and may only deploy one front air bag, depending on the severity of a collision and whether the front occupants are belted or unbelted. Information necessary to service the system safely is included in the SRS and SB section of this Service Manual.

WARNING:

- **To avoid rendering the SRS inoperative, which could increase the risk of personal injury or death in the event of a collision which would result in air bag inflation, all maintenance must be performed by an authorized NISSAN/INFINITI dealer.**
- **Improper maintenance, including incorrect removal and installation of the SRS, can lead to personal injury caused by unintentional activation of the system. For removal of Spiral Cable and Air Bag Module, see the SRS section.**
- **Do not use electrical test equipment on any circuit related to the SRS unless instructed to in this Service Manual. SRS wiring harnesses can be identified by yellow and/or orange harnesses or harness connectors.**

PREPARATION

PREPARATION

PF0:00002

Special Service Tools

EIS004E9

The actual shapes of Kent-Moore tools may differ from those of special service tools illustrated here.

Tool number (Kent-Moore No.) Tool name	Description
— (J-39570) Chassis ear	Locating the noise
— (J-43980) NISSAN Squeak and Rattle kit	Repairing the cause of noise

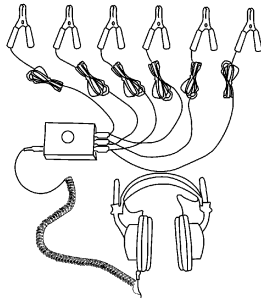

SBT839

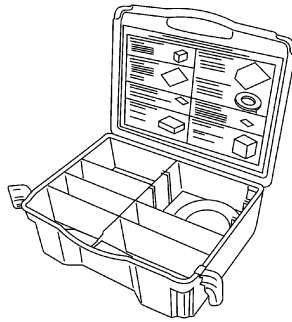

SBT840

Commercial Service Tools

EIS004EA

(Kent-Moore No.) Tool name	Description
(J-39565) Engine ear	Locating the noise

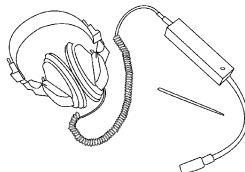

SIIA0995E

SQUEAK AND RATTLE TROUBLE DIAGNOSES

SQUEAK AND RATTLE TROUBLE DIAGNOSES

PF0:0000

Work Flow

EIS004EB

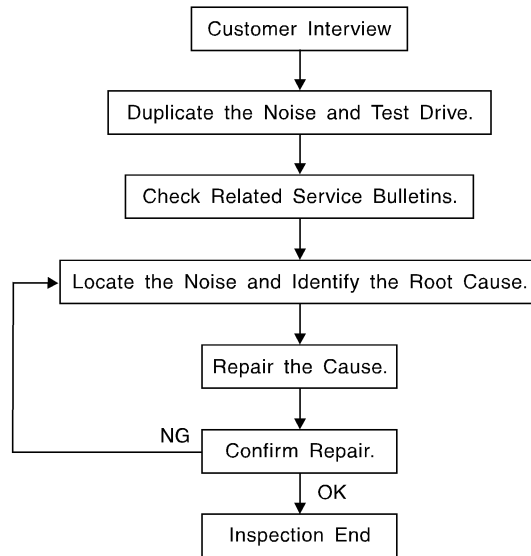

SBT842

CUSTOMER INTERVIEW

Interview the customer if possible, to determine the conditions that exist when the noise occurs. Use the Diagnostic Worksheet during the interview to document the facts and conditions when the noise occurs and any customer's comments; refer to [EI-9, "Diagnostic Worksheet"](#). This information is necessary to duplicate the conditions that exist when the noise occurs.

- The customer may not be able to provide a detailed description or the location of the noise. Attempt to obtain all the facts and conditions that exist when the noise occurs (or does not occur).
- If there is more than one noise in the vehicle, be sure to diagnose and repair the noise that the customer is concerned about. This can be accomplished by test driving the vehicle with the customer.
- After identifying the type of noise, isolate the noise in terms of its characteristics. The noise characteristics are provided so the customer, service adviser and technician are all speaking the same language when defining the noise.
- Squeak —(Like tennis shoes on a clean floor)
Squeak characteristics include the light contact/fast movement/brought on by road conditions/hard surfaces = higher pitch noise/softer surfaces = lower pitch noises/edge to surface = chirping.
- Creak—(Like walking on an old wooden floor)
Creak characteristics include firm contact/slow movement/twisting with a rotational movement/pitch dependent on materials/often brought on by activity.
- Rattle—(Like shaking a baby rattle)
Rattle characteristics include the fast repeated contact/vibration or similar movement/loose parts/missing clip or fastener/incorrect clearance.
- Knock —(Like a knock on a door)
Knock characteristics include hollow sounding/sometimes repeating/often brought on by driver action.
- Tick—(Like a clock second hand)
Tick characteristics include gentle contacting of light materials/loose components/can be caused by driver action or road conditions.
- Thump—(Heavy, muffled knock noise)
Thump characteristics include softer knock/dead sound often brought on by activity.
- Buzz—(Like a bumble bee)
Buzz characteristics include high frequency rattle/firm contact.
- Often the degree of acceptable noise level will vary depending upon the person. A noise that you may judge as acceptable may be very irritating to the customer.
- Weather conditions, especially humidity and temperature, may have a great effect on noise level.

SQUEAK AND RATTLE TROUBLE DIAGNOSES

DUPLICATE THE NOISE AND TEST DRIVE

If possible, drive the vehicle with the customer until the noise is duplicated. Note any additional information on the Diagnostic Worksheet regarding the conditions or location of the noise. This information can be used to duplicate the same conditions when you confirm the repair.

If the noise can be duplicated easily during the test drive, to help identify the source of the noise, try to duplicate the noise with the vehicle stopped by doing one or all of the following:

- 1) Close a door.
 - 2) Tap or push/pull around the area where the noise appears to be coming from.
 - 3) Rev the engine.
 - 4) Use a floor jack to recreate vehicle "twist".
 - 5) At idle, apply engine load (electrical load, half-clutch on M/T model, drive position on A/T model).
 - 6) Raise the vehicle on a hoist and hit a tire with a rubber hammer.
- Drive the vehicle and attempt to duplicate the conditions the customer states exist when the noise occurs.
 - If it is difficult to duplicate the noise, drive the vehicle slowly on an undulating or rough road to stress the vehicle body.

CHECK RELATED SERVICE BULLETINS

After verifying the customer concern or symptom, check ASIST for Technical Service Bulletins (TSBs) related to that concern or symptom.

If a TSB relates to the symptom, follow the procedure to repair the noise.

LOCATE THE NOISE AND IDENTIFY THE ROOT CAUSE

1. Narrow down the noise to a general area. To help pinpoint the source of the noise, use a listening tool (Chassis Ear: J-39570, Engine Ear: J-39565 and mechanic's stethoscope).
2. Narrow down the noise to a more specific area and identify the cause of the noise by:
 - removing the components in the area that you suspect the noise is coming from. Do not use too much force when removing clips and fasteners, otherwise clips and fasteners can be broken or lost during the repair, resulting in the creation of new noise.
 - tapping or pushing/pulling the component that you suspect is causing the noise. Do not tap or push/pull the component with excessive force, otherwise the noise will be eliminated only temporarily.
 - feeling for a vibration with your hand by touching the component(s) that you suspect is (are) causing the noise.
 - placing a piece of paper between components that you suspect are causing the noise.
 - looking for loose components and contact marks.
Refer to [EI-7, "Generic Squeak and Rattle Troubleshooting"](#).

REPAIR THE CAUSE

- If the cause is a loose component, tighten the component securely.
- If the cause is insufficient clearance between components:
 - separate components by repositioning or loosening and retightening the component, if possible.
 - insulate components with a suitable insulator such as urethane pads, foam blocks, felt cloth tape or urethane tape. A NISSAN Squeak and Rattle Kit (J-43980) is available through your authorized NISSAN Parts Department.

CAUTION:

Do not use excessive force as many components are constructed of plastic and may be damaged.

Always check with the Parts Department for the latest parts information.

The following materials are contained in the NISSAN Squeak and Rattle Kit (J-43980). Each item can be ordered separately as needed.

URETHANE PADS [1.5 mm (0.059 in) thick]

Insulates connectors, harness, etc.

76268-9E005: 100×135 mm (3.94×5.31 in)/76884-71L01: 60×85 mm (2.36×3.35 in)/76884-71L02: 15×25 mm (0.59×0.98 in)

INSULATOR (Foam blocks)

Insulates components from contact. Can be used to fill space behind a panel.

73982-9E000: 45 mm (1.77 in) thick, 50×50 mm (1.97×1.97 in)/73982-50Y00: 10 mm (0.39 in) thick, 50×50 mm (1.97×1.97 in)

INSULATOR (Light foam block)

SQUEAK AND RATTLE TROUBLE DIAGNOSES

80845-71L00: 30 mm (1.18 in) thick, 30×50 mm (1.18×1.97 in)

FELT CLOTH TAPE

Used to insulate where movement does not occur. Ideal for instrument panel applications.

68370-4B000: 15×25 mm (0.59×0.98 in) pad/68239-13E00: 5 mm (0.20 in) wide tape roll. The following materials not found in the kit can also be used to repair squeaks and rattles.

UHMW (TEFLON) TAPE

Insulates where slight movement is present. Ideal for instrument panel applications.

SILICONE GREASE

Used instead of UHMW tape that will be visible or not fit.

Note: Will only last a few months.

SILICONE SPRAY

Use when grease cannot be applied.

DUCT TAPE

Use to eliminate movement.

CONFIRM THE REPAIR

Confirm that the cause of a noise is repaired by test driving the vehicle. Operate the vehicle under the same conditions as when the noise originally occurred. Refer to the notes on the Diagnostic Worksheet.

Generic Squeak and Rattle Troubleshooting

EIS004EC

Refer to Table of Contents for specific component removal and installation information.

INSTRUMENT PANEL

Most incidents are caused by contact and movement between:

1. The cluster lid A and instrument panel
2. Acrylic lens and combination meter housing
3. Instrument panel to front pillar garnish
4. Instrument panel to windshield
5. Instrument panel mounting pins
6. Wiring harnesses behind the combination meter
7. A/C defroster duct and duct joint

These incidents can usually be located by tapping or moving the components to duplicate the noise or by pressing on the components while driving to stop the noise. Most of these incidents can be repaired by applying felt cloth tape or silicone spray (in hard to reach areas). Urethane pads can be used to insulate wiring harness.

CAUTION:

Do not use silicone spray to isolate a squeak or rattle. If you saturate the area with silicone, you will not be able to recheck the repair.

CENTER CONSOLE

Components to pay attention to include:

1. Shifter assembly cover to finisher
2. A/C control unit and cluster lid C
3. Wiring harnesses behind audio and A/C control unit

The instrument panel repair and isolation procedures also apply to the center console.

DOORS

Pay attention to the:

1. Finisher and inner panel making a slapping noise
2. Inside handle escutcheon to door finisher
3. Wiring harnesses tapping
4. Door striker out of alignment causing a popping noise on starts and stops

Tapping or moving the components or pressing on them while driving to duplicate the conditions can isolate many of these incidents. You can usually insulate the areas with felt cloth tape or insulator foam blocks from the NISSAN Squeak and Rattle Kit (J-43980) to repair the noise.

A
B
C
D
E
F
G
H
EI
J
K
L
M

SQUEAK AND RATTLE TROUBLE DIAGNOSES

TRUNK

Trunk noises are often caused by a loose jack or loose items put into the trunk by the owner. In addition look for:

1. Trunk lid bumpers out of adjustment
2. Trunk lid striker out of adjustment
3. The trunk lid torsion bars knocking together
4. A loose license plate or bracket

Most of these incidents can be repaired by adjusting, securing or insulating the item(s) or component(s) causing the noise.

SUNROOF/HEADLINING

Noises in the sunroof/headlining area can often be traced to one of the following:

1. Sunroof lid, rail, linkage or seals making a rattle or light knocking noise
2. Sun visor shaft shaking in the holder
3. Front or rear windshield touching headliner and squeaking

Again, pressing on the components to stop the noise while duplicating the conditions can isolate most of these incidents. Repairs usually consist of insulating with felt cloth tape.

OVERHEAD CONSOLE (FRONT AND REAR)

Overhead console noises are often caused by the console panel clips not being engaged correctly. Most of these incidents are repaired by pushing up on the console at the clip locations until the clips engage.

In addition look for:

1. Loose harness or harness connectors.
2. Front console map/reading lamp lens loose.
3. Loose screws at console attachment points.

SEATS

When isolating seat noise it's important to note the position the seat is in and the load placed on the seat when the noise is present. These conditions should be duplicated when verifying and isolating the cause of the noise.

Cause of seat noise include:

1. Headrest rods and holder
2. A squeak between the seat pad cushion and frame
3. The rear seatback lock and bracket

These noises can be isolated by moving or pressing on the suspected components while duplicating the conditions under which the noise occurs. Most of these incidents can be repaired by repositioning the component or applying urethane tape to the contact area.

UNDERHOOD

Some interior noise may be caused by components under the hood or on the engine wall. The noise is then transmitted into the passenger compartment.

Causes of transmitted underhood noise include:

1. Any component mounted to the engine wall
2. Components that pass through the engine wall
3. Engine wall mounts and connectors
4. Loose radiator mounting pins
5. Hood bumpers out of adjustment
6. Hood striker out of adjustment

These noises can be difficult to isolate since they cannot be reached from the interior of the vehicle. The best method is to secure, move or insulate one component at a time and test drive the vehicle. Also, engine RPM or load can be changed to isolate the noise. Repairs can usually be made by moving, adjusting, securing, or insulating the component causing the noise.

SQUEAK AND RATTLE TROUBLE DIAGNOSES

EIS004ED

Diagnostic Worksheet

Dear Customer:

We are concerned about your satisfaction with your vehicle. Repairing a squeak or rattle sometimes can be very difficult. To help us fix your vehicle right the first time, please take a moment to note the area of the vehicle where the squeak or rattle occurs and under what conditions. You may be asked to take a test drive with a service advisor or technician to ensure we confirm the noise you are hearing.

SQUEAK & RATTLE DIAGNOSTIC WORKSHEET

I. WHERE DOES THE NOISE COME FROM? (circle the area of the vehicle)

The illustrations are for reference only, and may not reflect the actual configuration of your vehicle.

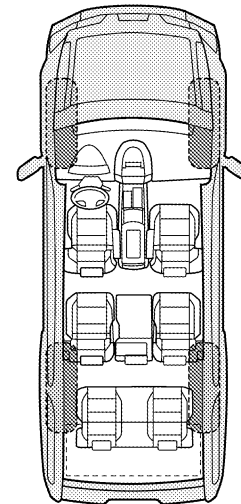
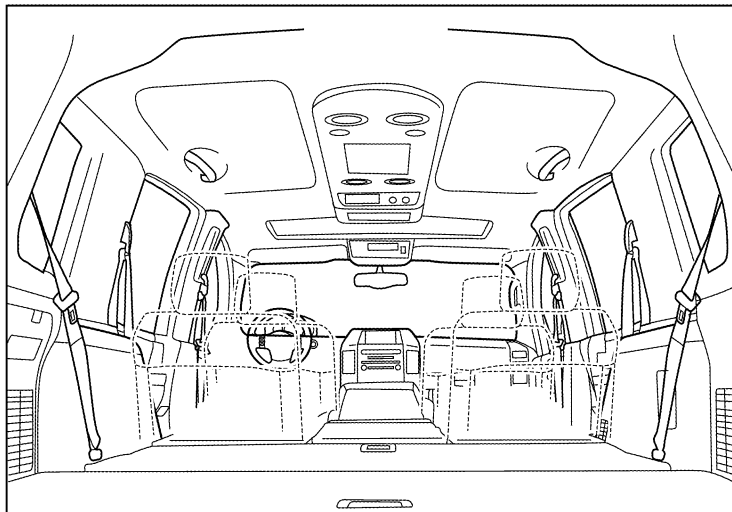
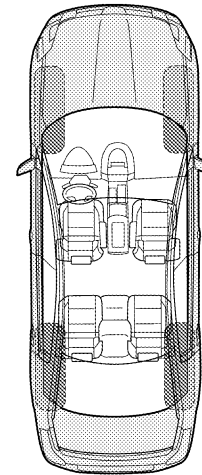
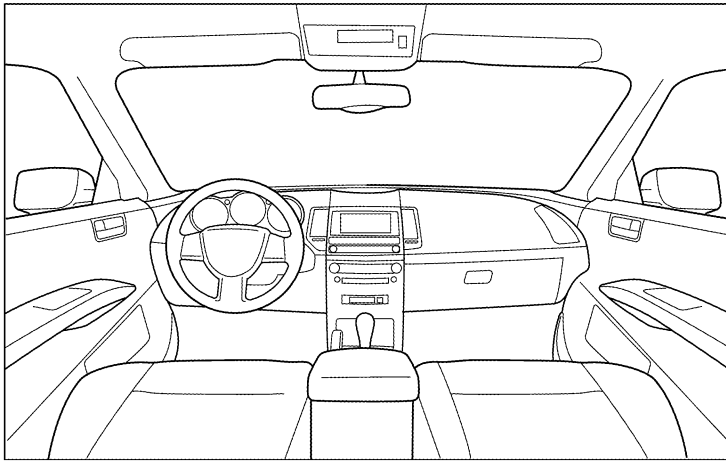

Continue to page 2 of the worksheet and briefly describe the location of the noise or rattle. In addition, please indicate the conditions which are present when the noise occurs.

A
B
C
D
E
F
G
H
EI
J
K
L
M

SQUEAK AND RATTLE TROUBLE DIAGNOSES

SQUEAK & RATTLE DIAGNOSTIC WORKSHEET - page 2

Briefly describe the location where the noise occurs:

II. WHEN DOES IT OCCUR? (please check the boxes that apply)

- | | |
|---|--|
| <input type="checkbox"/> Anytime | <input type="checkbox"/> After sitting out in the rain |
| <input type="checkbox"/> 1st time in the morning | <input type="checkbox"/> When it is raining or wet |
| <input type="checkbox"/> Only when it is cold outside | <input type="checkbox"/> Dry or dusty conditions |
| <input type="checkbox"/> Only when it is hot outside | <input type="checkbox"/> Other: |

III. WHEN DRIVING:

- Through driveways
- Over rough roads
- Over speed bumps
- Only about ____ mph
- On acceleration
- Coming to a stop
- On turns: left, right or either (circle)
- With passengers or cargo
- Other: _____
- After driving ____ miles or ____ minutes

IV. WHAT TYPE OF NOISE

- Squeak (like tennis shoes on a clean floor)
- Creak (like walking on an old wooden floor)
- Rattle (like shaking a baby rattle)
- Knock (like a knock at the door)
- Tick (like a clock second hand)
- Thump (heavy muffled knock noise)
- Buzz (like a bumble bee)

TO BE COMPLETED BY DEALERSHIP PERSONNEL

Test Drive Notes:

	YES	NO	Initials of person performing
Vehicle test driven with customer	<input type="checkbox"/>	<input type="checkbox"/>	_____
- Noise verified on test drive	<input type="checkbox"/>	<input type="checkbox"/>	_____
- Noise source located and repaired	<input type="checkbox"/>	<input type="checkbox"/>	_____
- Follow up test drive performed to confirm repair	<input type="checkbox"/>	<input type="checkbox"/>	_____

LAI0071E







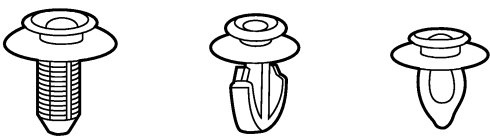

CLIP AND FASTENER

CLIP AND FASTENER

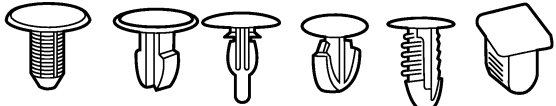
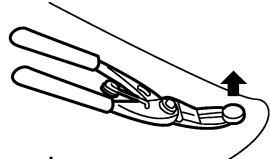
PFP:76906

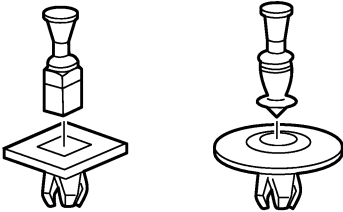
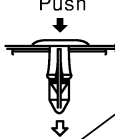
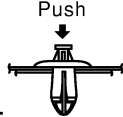
Clip and Fastener

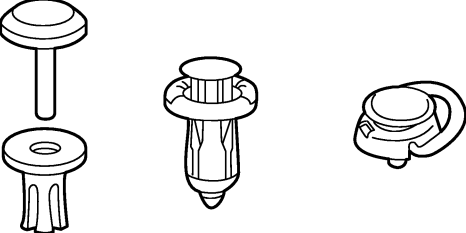

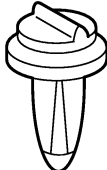
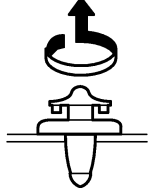





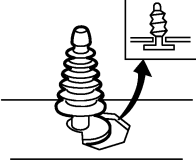
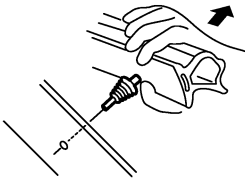

EIS004EE

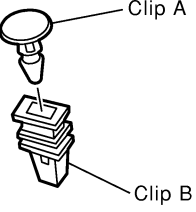
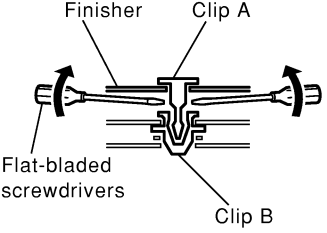
Symbol No.	Shapes	Removal & Installation
<p>C101</p> 		<p>Removal: Remove by bending up with flat-bladed screwdrivers or clip remover.</p> 
<p>C103</p> 		 <p>Removal: Remove with a clip remover.</p>
<p>C203</p> 		<p>Removal: Push center pin to catching position. (Do not remove center pin by hitting it.)</p> <p>Push</p>  <p>Installation:</p> <p>Push</p> 
<p>C205</p> 		<p>Removal:</p> <p>Flat-bladed screwdriver</p>  <p>Clip</p> <p>Finisher</p>
<p>C206</p> 		<p>Removal:</p> 

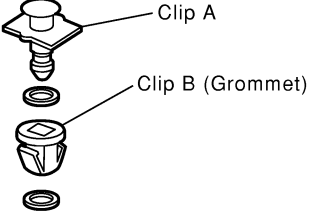
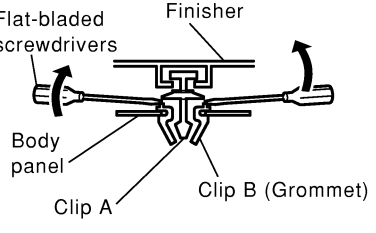
A
B
C
D
E
F
G
H
EI
J
K
L
M

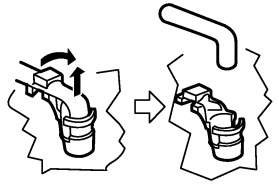

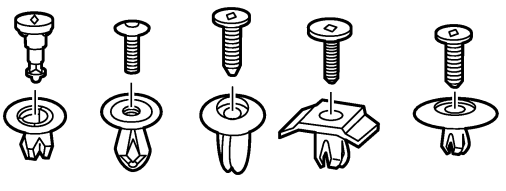





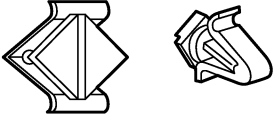

SIA0315E

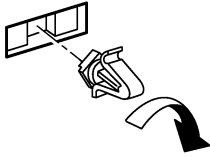
CLIP AND FASTENER

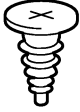
Symbol No.	Shapes	Removal & Installation
<p>CE103</p> 		<p>Removal:</p> 
<p>CF110</p> 		<p>Removal:</p> 
<p>CF118</p> 		<p>Removal:</p> 
<p>CR103</p> 		<p>Removal: Holder portion of clip must be spread out to remove rod.</p> 
<p>CS101</p> 		<p>Removal:</p> <ol style="list-style-type: none"> 1. Screw out with a Phillips screwdriver. 2. Remove female portion with flat-bladed screwdriver. 

SIIA0316E

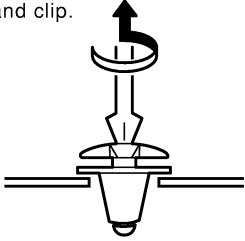
CLIP AND FASTENER

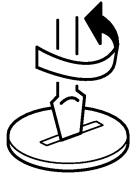
Symbol No.	Shapes	Removal & Installation	
CG101 		Removal:  Rotate 45° to remove	Installation: 
CS102 			
CS113 		Removal: Disconnect upper connection of clip with a flat-bladed screwdriver, then remove clip while inserting a flat-bladed screwdriver between body panel and clip. 	
C111 			

A
B
C
D
E
F
G
H
EI
J
K
L
M

SIIA0317E

FRONT BUMPER

FRONT BUMPER

PFP:F2022

Removal and Installation STEEL BUMPER

EIS004EF

SEC. 620

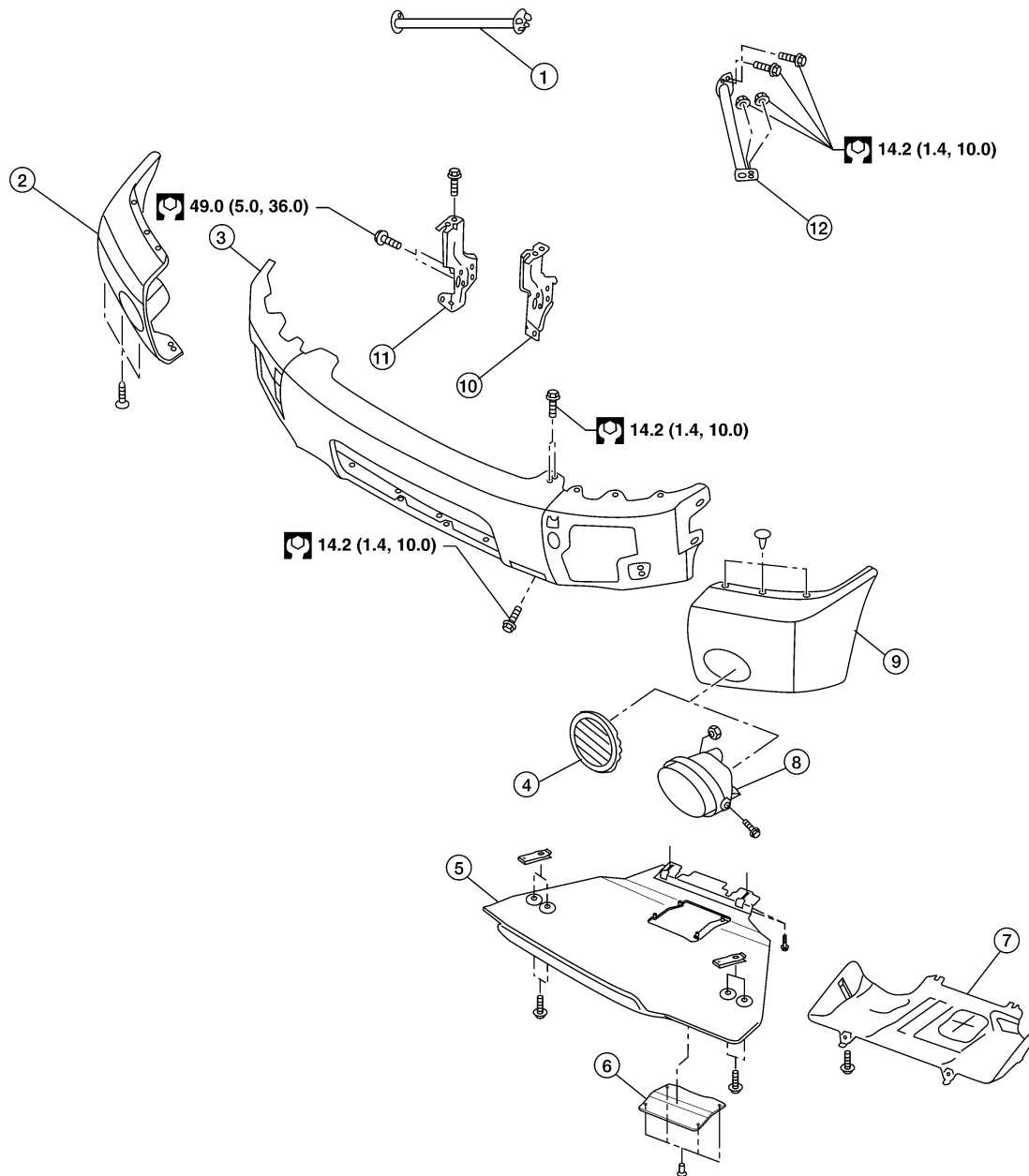

W1IA0982E

- | | | |
|---|---------------------------------------|-----------------------------|
| 1. Front bumper bracket RH | 2. Front fascia finisher RH | 3. Front bumper assembly |
| 4. Fog lamp opening finisher (if equipped) | 5. Skid plate (with off-road package) | 6. Access cover |
| 7. Front under cover (without off-road package) | 8. Fog lamp assembly (if equipped) | 9. Front fascia finisher LH |
| 10. Front bumper bracket stay RH | 11. Front bumper bracket stay LH | 12. Front bumper bracket LH |

Removal

1. Remove radiator grille. Refer to [EI-20, "FRONT GRILLE"](#).
2. Remove engine under cover or skid plate.

FRONT BUMPER

3. Remove the fog lamp (if equipped). Refer to [LT-75, "Removal and Installation"](#) .
4. Remove the front bumper side bracket nuts.
5. Remove front bumper assembly.
6. Remove front bumper RH and LH side finishers.
7. Remove front bumper brackets LH and RH.
8. Remove front bumper stays LH and RH.

Installation

Installation is in the reverse order of removal.

A

B

C

D

E

F

G

H

EI

J

K

L

M

FRONT BUMPER

PLASTIC BUMPER

SEC. 620

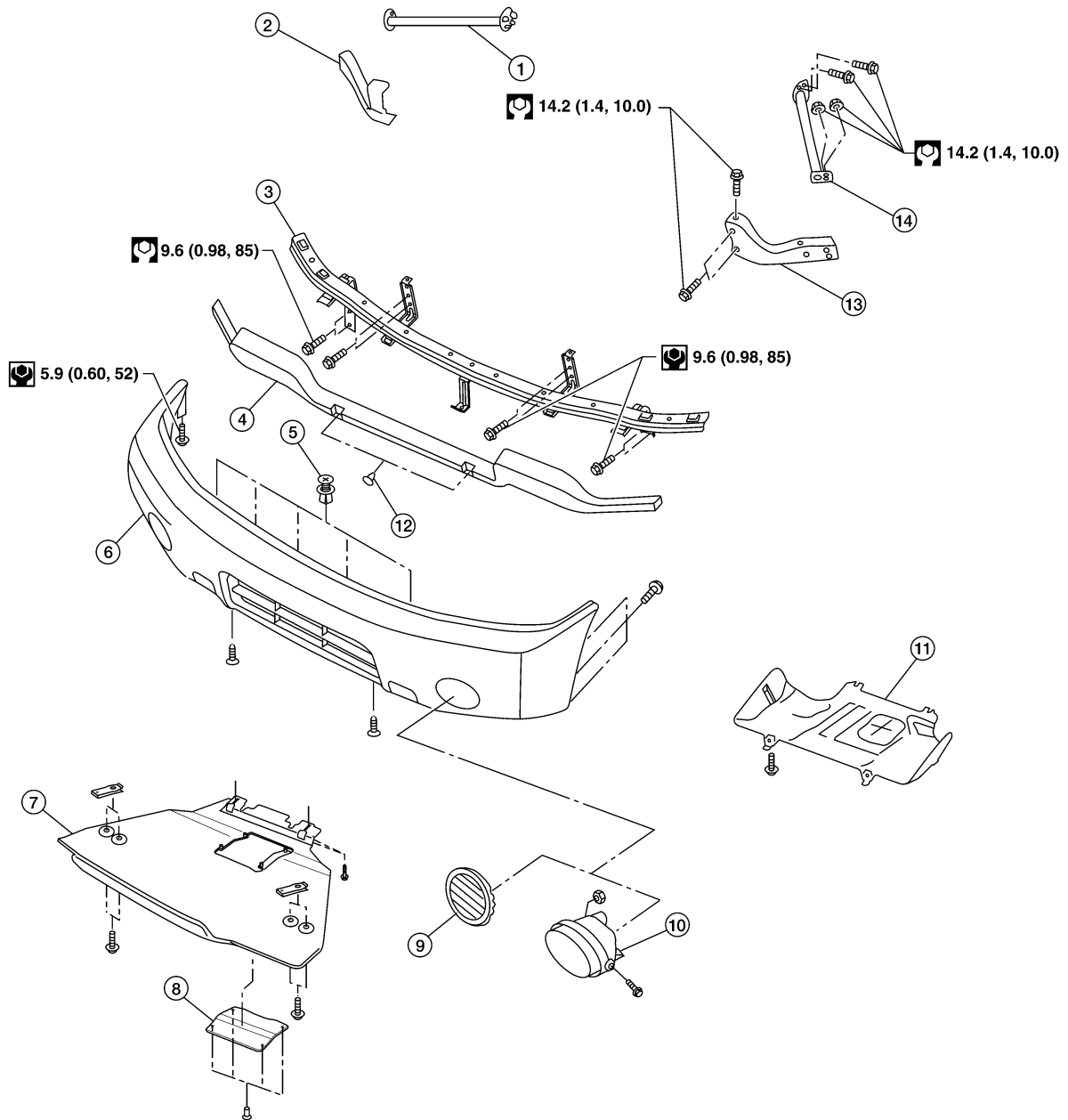

- | | | |
|---------------------------------------|--|--|
| 1. Front bumper bracket RH | 2. Front bumper stay RH | 3. Retainer bracket |
| 4. Energy absorber | 5. Fastener CS101 | 6. Plastic fascia assembly |
| 7. Skid plate (with off-road package) | 8. Access cover | 9. Fog lamp opening finisher (if equipped) |
| 10. Fog lamp assembly (if equipped) | 11. Front under cover (without off-road package) | 12. Plastic clip |
| 13. Front bumper stay LH | 14. Front bumper bracket LH | |

WIIA0983E

Removal

1. Remove radiator grille. Refer to [EI-20, "FRONT GRILLE"](#).
2. Remove skid plate or front under cover
3. Remove fog lamp, if equipped. Refer to [LT-75, "Removal and Installation"](#).
4. Remove screws and fasteners and remove plastic fascia assembly.

FRONT BUMPER

- Remove fog lamp assembly, if equipped, from plastic fascia assembly.
 - Remove fog lamp opening finisher, if equipped, from plastic fascia assembly.
5. Remove clips and energy absorber from retainer bracket.
 6. Remove retainer bracket.
 7. Remove front bumper brackets LH and RH.
 8. Remove front bumper stays LH and RH.

Installation

Installation is in the reverse order of removal.

A

B

C

D

E

F

G

H

EI

J

K

L

M

REAR BUMPER

PFP:H5022

EIS004EG

REAR BUMPER

Removal and Installation

SEC. 850

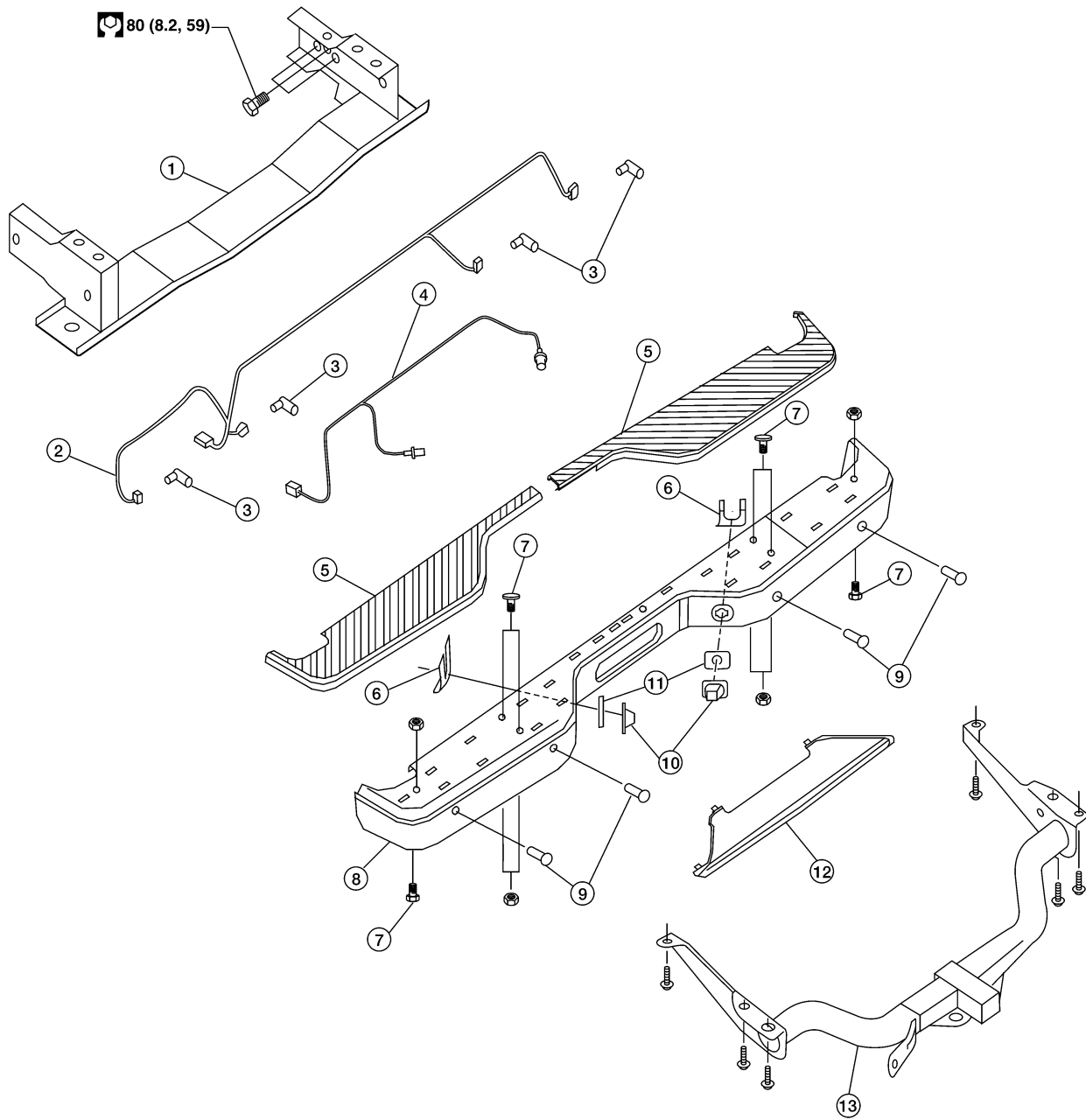

- | | | |
|------------------------------|-------------------------|--------------------------|
| 1. Rear bumper reinforcement | 2. Sonar sensor harness | 3. Sonar sensor |
| 4. License lamp harness | 5. Upper step pad | 6. License lamp clip |
| 7. Carriage bolt | 8. Rear chrome bumper | 9. Sonar sensor retainer |
| 10. License lamp | 11. License lamp washer | 12. Lower step pad |
| 13. Tow hitch (if equipped) | | |

W1IA0984E

REMOVAL

NOTE:

It is not necessary to remove the tow hitch to service the rear bumper.

1. Disconnect harness from tow hitch, if equipped.
2. Remove bolts on each side of tow hitch and remove tow hitch, if equipped.

REAR BUMPER

3. Disconnect sonar sensor harness connector, if equipped.
 - Disconnect sonar sensors from retainers.
4. Disconnect license lamp harness.
5. Remove clips from license lamps and remove lamps.
6. Release clips and remove upper step pads.
7. Remove rear chrome bumper.
8. Disconnect harness clips from black steel bumper.
9. Remove rear bumper reinforcement.
10. Remove sonar sensor retainers from rear chrome bumper, if equipped.
11. Remove sonar sensors and harness from rear chrome bumper, if equipped.
 - Disconnect sonar sensors from harness.
12. Remove license lamp harness from rear chrome bumper.

INSTALLATION

Installation is in the reverse order of removal.

- Apply sealant to clips securing upper step pad during installation.

A

B

C

D

E

F

G

H

EI

J

K

L

M

FRONT GRILLE

FRONT GRILLE

PF6:62310

Removal and Installation

EIS004EH

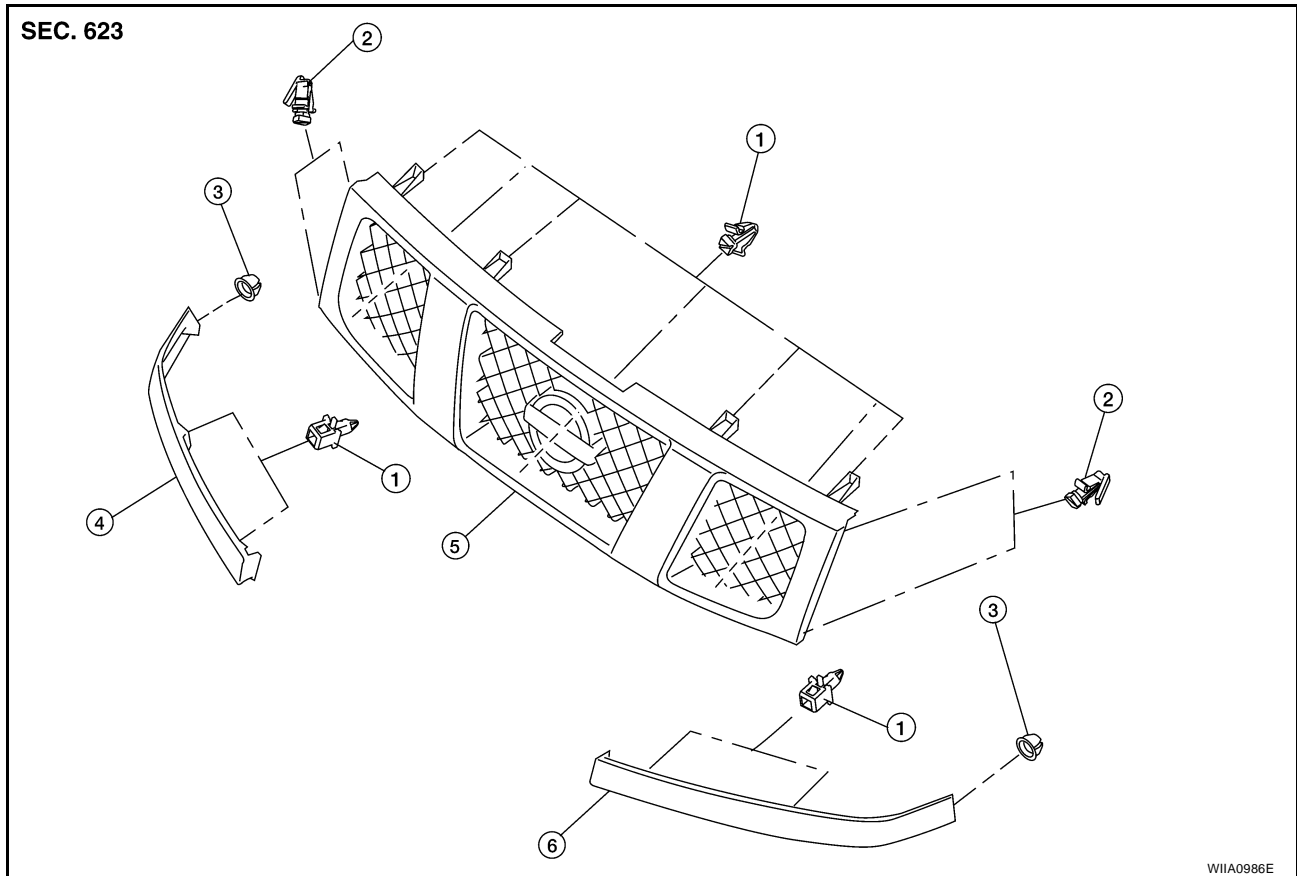

- | | | |
|---------------------------------|-----------------------|---------------------------------|
| 1. Plastic clip CG101 | 2. Plastic clip CG101 | 3. Grommet |
| 4. Front bumper filler panel RH | 5. Front grille | 6. Front bumper filler panel LH |

REMOVAL

1. Release plastic clips and remove front grille.
2. Remove LH and RH front bumper filler panels.

INSTALLATION

Installation is in the reverse order of removal.

COWL TOP

PF6:66100

COWL TOP

Removal and Installation

EIS004EI

SEC. 660

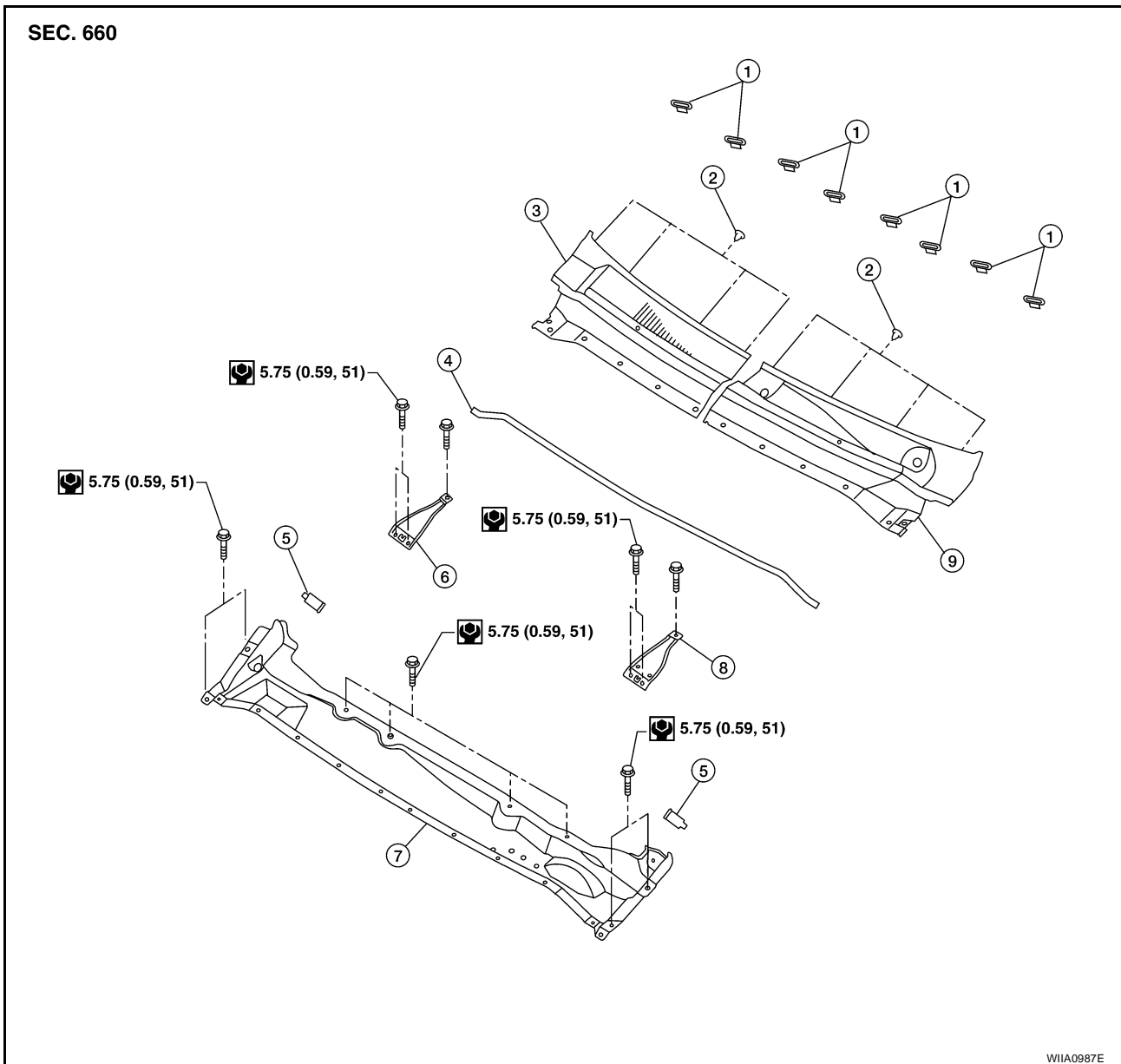

- | | | |
|-----------------------|----------------------------------|----------------------------------|
| 1. Grommet | 2. Plastic clip C103 | 3. Cowl top RH |
| 4. Cowl top seal | 5. Drain tube | 6. Cowl top extension bracket RH |
| 7. Cowl top extension | 8. Cowl top extension bracket LH | 9. Cowl top LH |

REMOVAL

1. Remove right and left wiper arms. Refer to [WW-28, "Front Wiper Arms"](#).
2. Remove cowl top seal.
 - Release plastics clips on cowl top seal which go through cowl tops LH and RH and cowl top extension.
3. Remove cowl top covers LH and RH.
 - Release plastic clips under cowl top covers attaching to grommets on hoodledge.
 - Disconnect washer tubes from washer nozzles.
4. Remove cowl top extension brackets LH and RH.
 - Disconnect wiper motor harness from cowl top extension bracket LH.
 - Cowl top extension bracket LH must be removed prior to removal of wiper motor and connecting rod assembly.

A
B
C
D
E
F
G
H
EI
J
K
L
M

COWL TOP

5. Remove wiper motor and connecting rod linkage. Refer to [WW-29, "Wiper Motor and Linkage"](#) .
6. Disconnect windshield washer tube. Refer to [WW-30, "Washer Tube Layout"](#) .
7. Remove A/C low-pressure pipe bracket from cowl top extension. Refer to [MTC-112, "REFRIGERANT LINES"](#) .
8. Remove drain tube from each side of cowl top extension.
9. Remove cowl top extension.

INSTALLATION

Installation is in the reverse order of removal.

FRONT FENDER

PFP:63100

FRONT FENDER

Removal and Installation

EIS004EJ

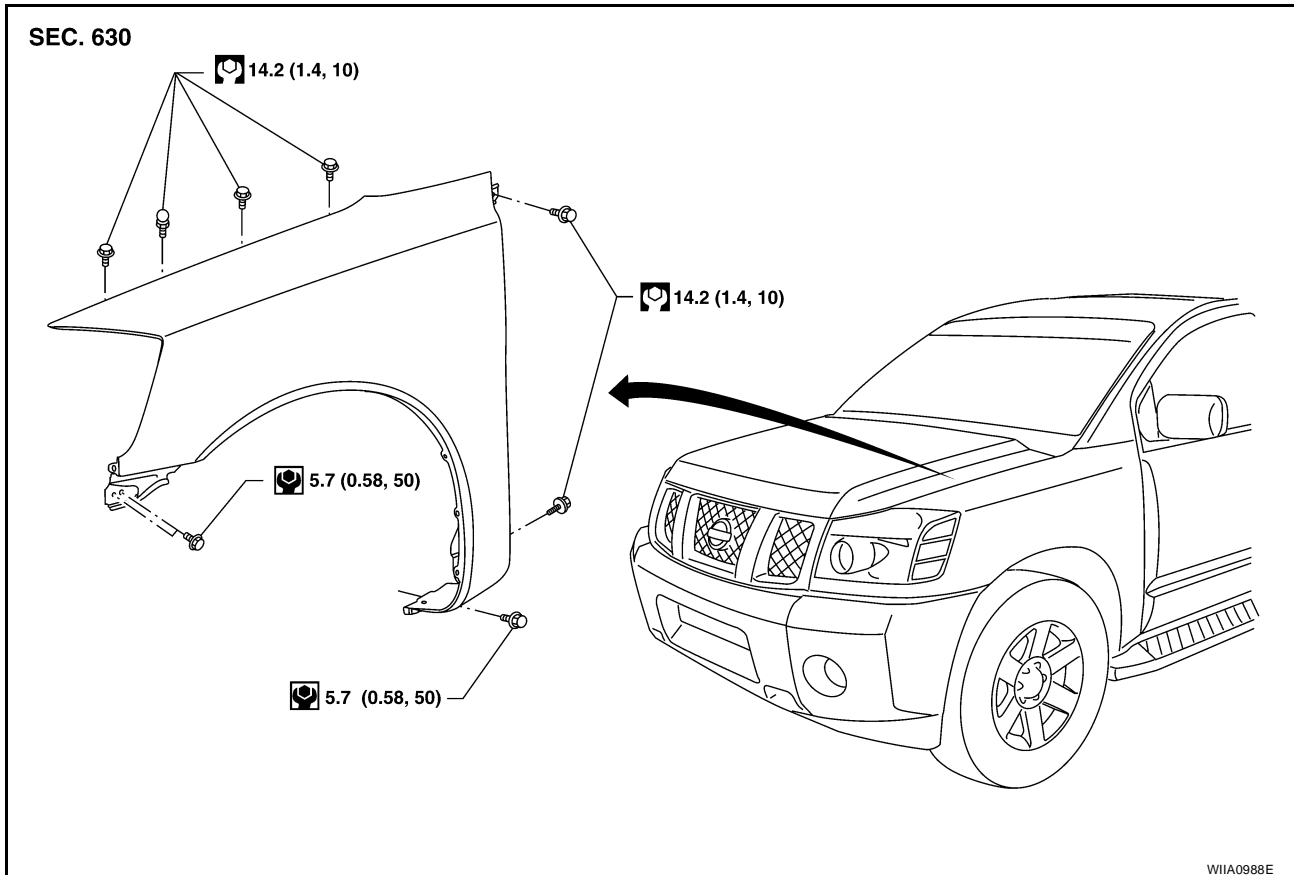

REMOVAL

1. Remove the front mudguards (if equipped). Refer to [EI-27, "MUDGUARD"](#) .
2. Remove headlamps. Refer to [LT-31, "Removal and Installation"](#) .
3. Remove fender protector. Refer to [EI-24, "FENDER PROTECTOR"](#) .
4. Remove hood stay. Refer to [BL-12, "HOOD"](#) .
5. Remove front fender.

INSTALLATION

Installation is in the reverse order of removal.

A
B
C
D
E
F
G
H
EI
J
K
L
M

FENDER PROTECTOR

PF6:63840

FENDER PROTECTOR Removal and Installation

EIS004EK

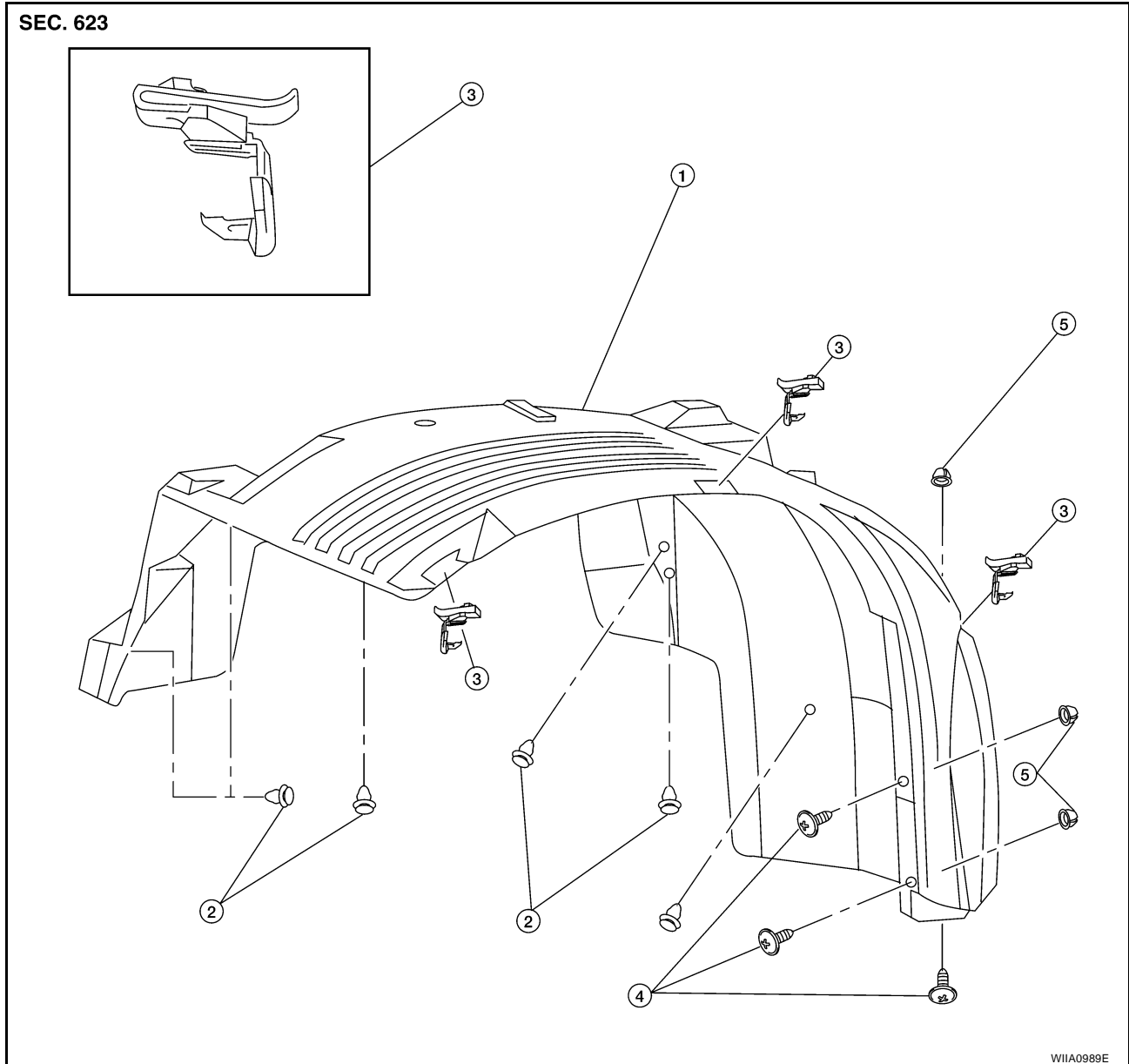

- | | | |
|------------------------|------------------|-----------------|
| 1. Fender protector LH | 2. Pushpin CS101 | 3. Plastic clip |
| 4. Screw | 5. Grommet | |

REMOVAL

1. Remove front mudguard. Refer to [EI-27, "MUDGUARD"](#).
2. Remove screws.
3. Remove plastic clips.
4. Remove pushpins.
5. Remove front fender protector.

INSTALLATION

Installation is in the reverse order of removal.

RUNNING BOARDS

RUNNING BOARDS

Removal and Installation

PF9:96110

EIS004EL

SEC. 767

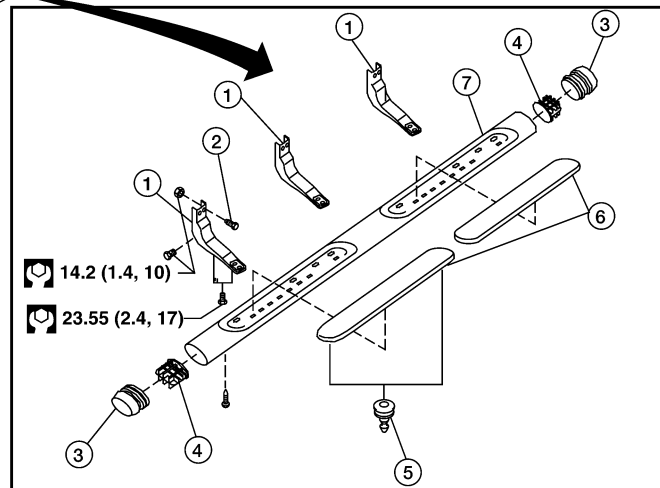
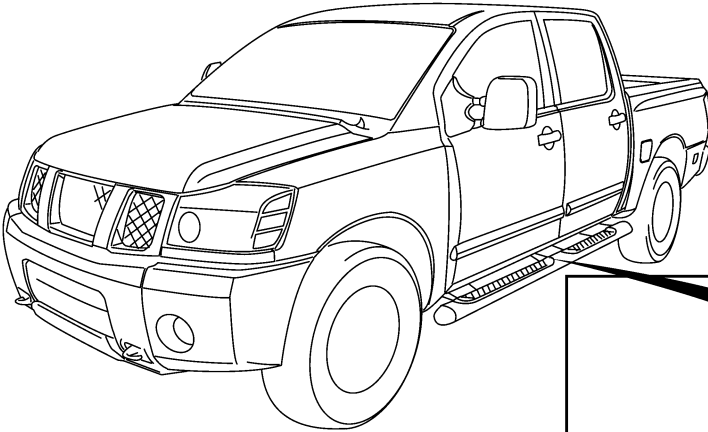
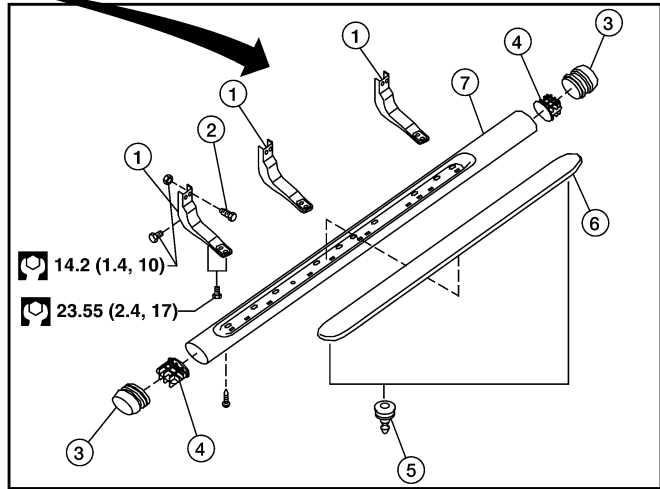
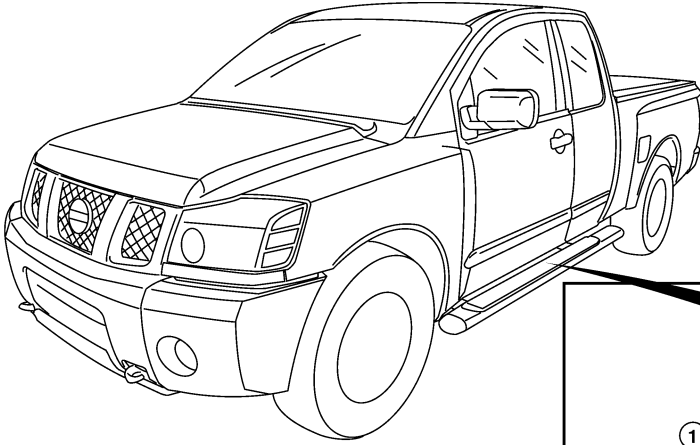

WIA0994E

A
B
C
D
E
F
G
H
EI
J
K
L
M

RUNNING BOARDS

- | | | |
|--------------------------|-----------------|-------------|
| 1. Running board bracket | 2. Weld stud | 3. End cap |
| 4. End cap reinforcement | 5. Plastic clip | 6. Step pad |
| 7. Running board | | |

REMOVAL

1. Remove bolts and remove running board from running board brackets.
2. Remove screw and remove end cap.
 - Remove reinforcement from end cap.
3. Release clips and remove step pad from running board.
4. Remove nuts and bolts and remove running board brackets.

INSTALLATION

Installation is in the reverse order of removal.

MUDGUARD

MUDGUARD

PFP:63854

Removal and Installation

EIS004EM

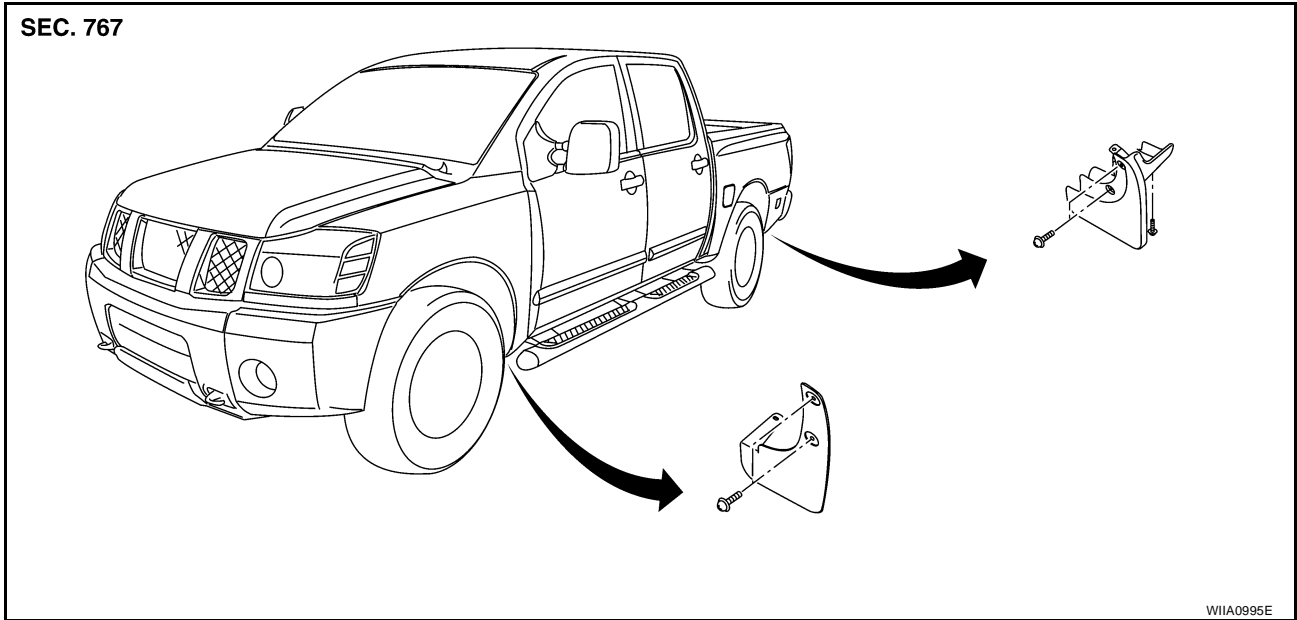

NOTE:
Crew Cab shown King Cab similar.

A
B
C
D
E
F
G
H
I
J
K
L
M

EI

DOOR OUTSIDE MOLDING

DOOR OUTSIDE MOLDING

PFP:82820

Removal and Installation

EIS004EN

SEC. 800 • 820

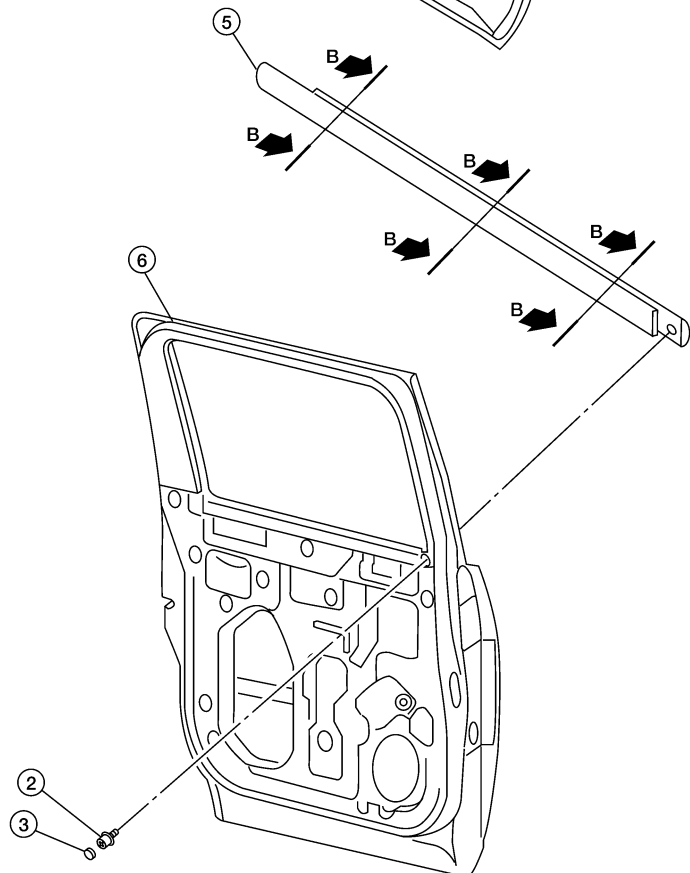
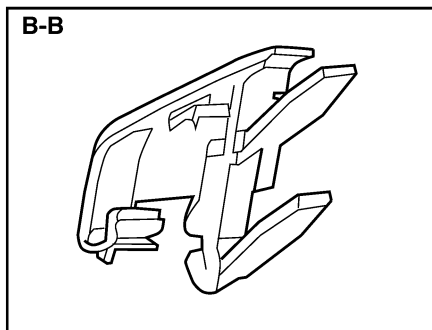
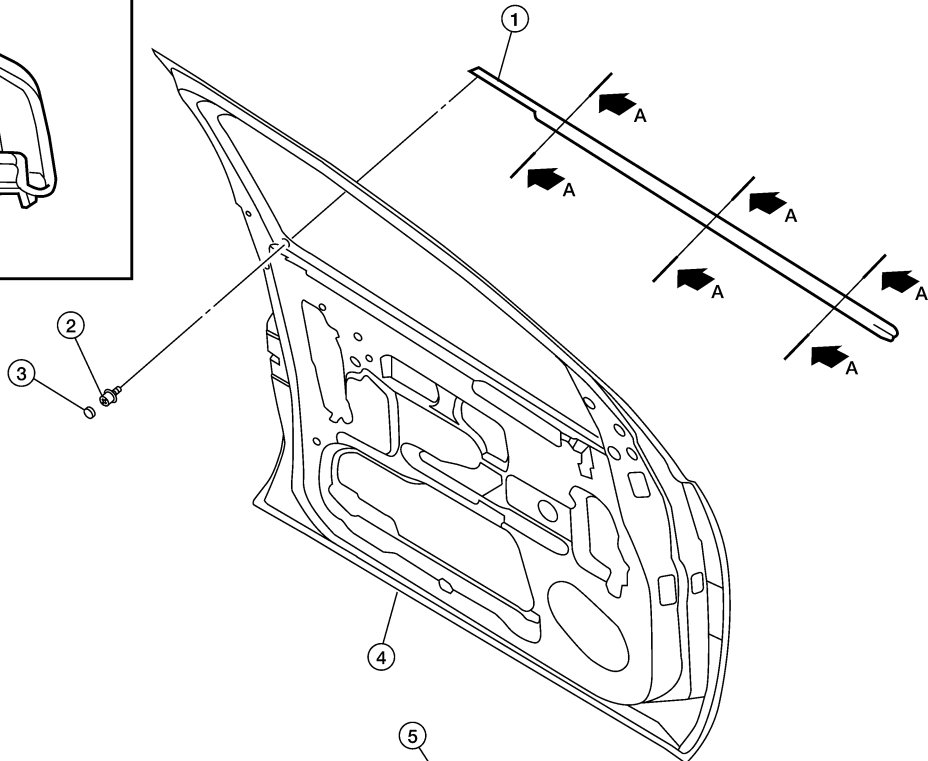
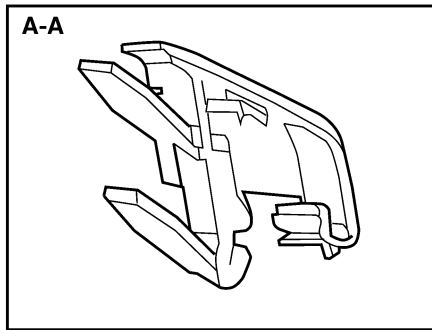

WIAA0996E

DOOR OUTSIDE MOLDING

- | | | | |
|----------------------------------|---------------------------------|-----------------------|---|
| 1. Front door outside molding LH | 2. Screw | 3. Hole cover | A |
| 4. Front door LH | 5. Rear door outside molding LH | 6. Rear door-Crew cab | |

FRONT DOOR OUTSIDE MOLDING

Removal

1. Open window fully.
2. Remove door mirror. Refer to [GW-120, "DOOR MIRROR"](#).
3. Remove molding.
 - Remove hole cover and screw.
 - Lift molding from rear side.
 - Disconnect clips from flange.

Installation

Installation is in the reverse order of removal.

REAR DOOR OUTSIDE MOLDING

Removal

1. Open window fully.
2. Remove molding.
 - Remove hole cover and screw.
 - Lift molding from rear side.
 - Disconnect clips from flange.

Installation

Installation is in the reverse order of removal.

A

B

C

D

E

F

G

H

EI

J

K

L

M

SIDE GUARD MOLDING

SIDE GUARD MOLDING Removal and Installation

PFP:76840

EIS004E0

SEC. 766

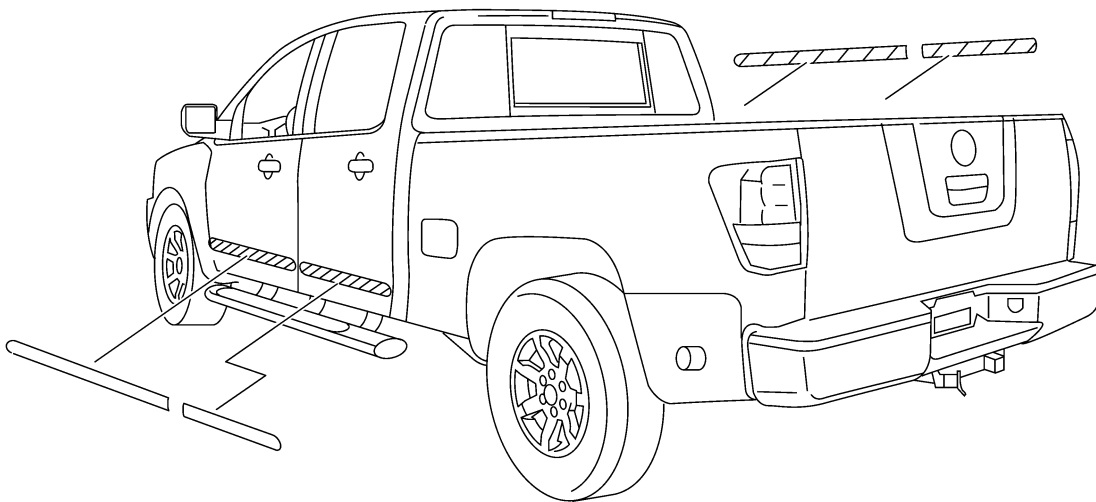
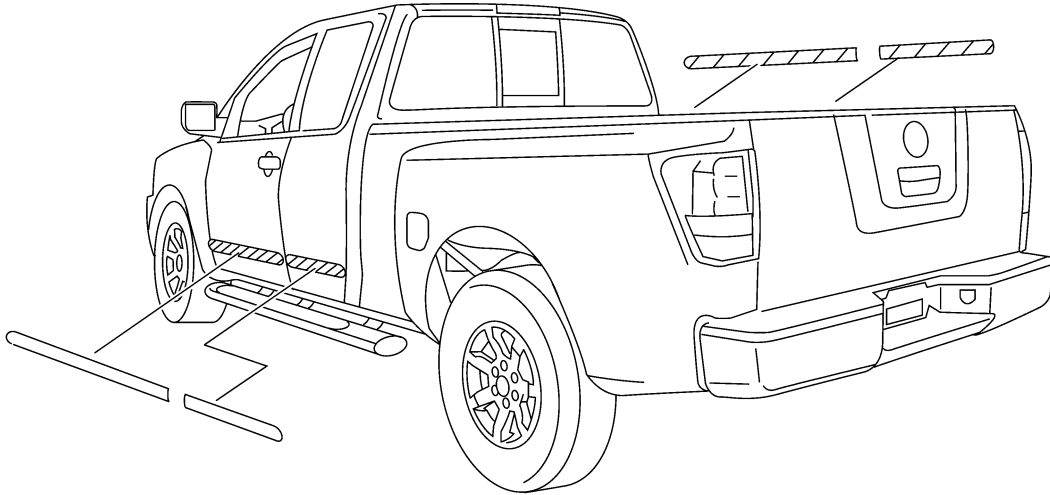

W1IA0997E

SIDE GUARD MOLDING

A Double-faced adhesive tape application locations

REMOVAL

CAUTION:

Never apply tack-paper adhesive remover to body panel surface finished with lacquer-based paints.

- Original side guard molding is affixed to body panel with double-faced adhesive tape.
- 1. Heat molding to between 30° and 40°C (86° to 104°F) with a heat gun.
- 2. Raise end of molding and cut away tape to remove molding. Remove all traces of tape.

INSTALLATION

- On vehicles coated with Hard Clear Coat, use double-faced 3M adhesive tape Product No. 4210 or equivalent, after priming with 3M primer Product No. N200, C-100 or equivalent.
- The repair parts are also affixed with double-faced adhesive tape.
- To re-use existing molding, clean all traces of double sided tape from the molding and apply new double-faced tape to the molding.
- 1. Clean the panel surface with isopropyl alcohol or equivalent to degrease the surface.
- 2. Heat the panel and molding tape surface to 30° to 40°C (86° to 104°F).
- 3. Remove the backing sheet from the tape surface.
 - Align the locating pin into the hole in the outer door.
 - Continue aligning the pins into their corresponding holes in the outer door during installation.
- 4. Press ends by hand and use a roller to apply 5 kg-f (11 lbs-f) to press molding to door surface.
 - Apply even pressure along molding to insure proper wet out.

CAUTION:

To secure contact, do not wash vehicle for 24 hours after installation.

A

B

C

D

E

F

G

H

EI

J

K

L

M

DOOR FINISHER

PF80900

DOOR FINISHER

Removal and Installation FRONT DOOR

EIS004EP

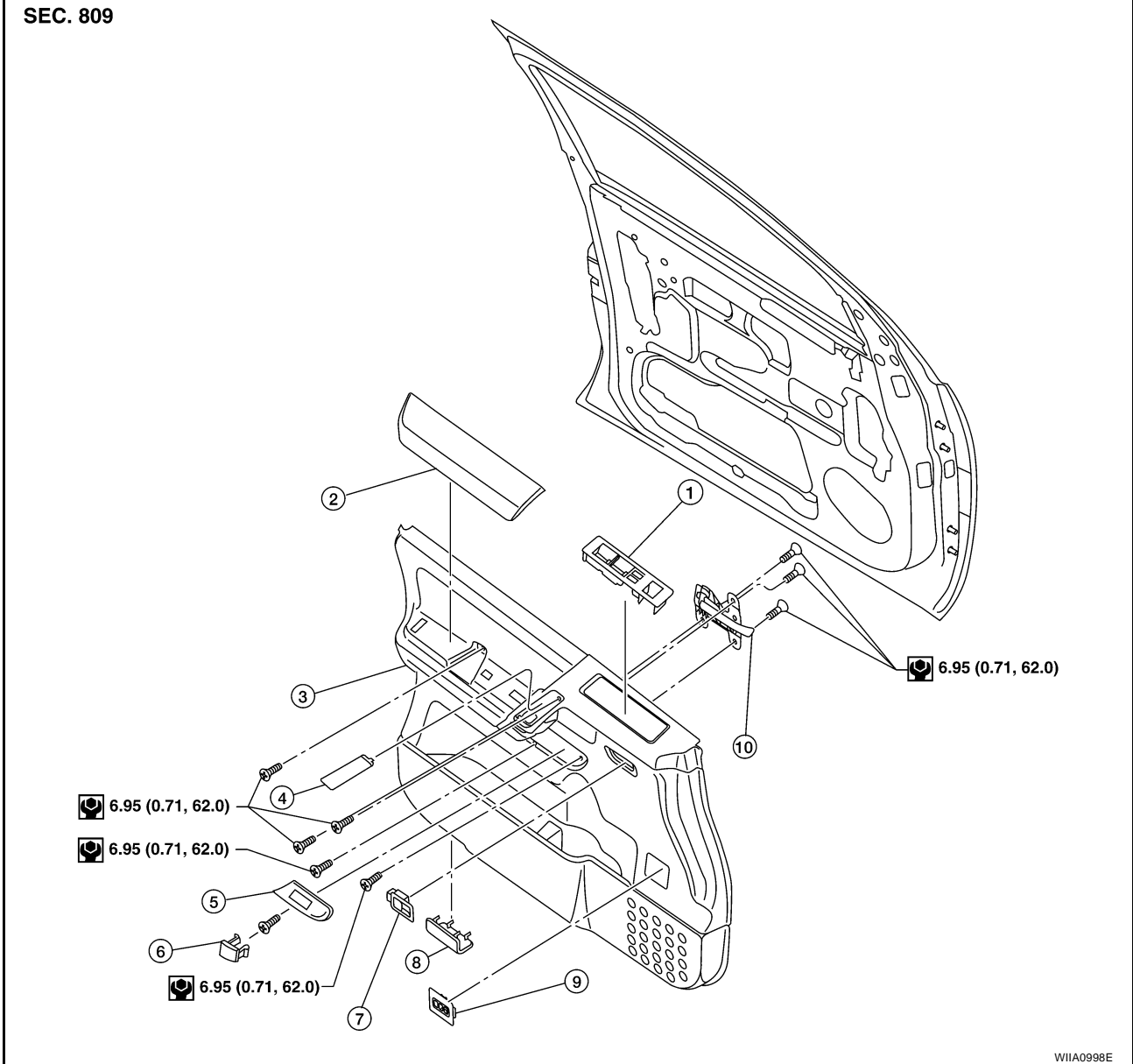

- | | | |
|---|---------------------------|-------------------------------------|
| 1. Power window switch assembly (if equipped) | 2. Armrest | 3. Front door finisher LH |
| 4. Pull handle cover | 5. Pull handle escutcheon | 6. Cap |
| 7. Door lock knob | 8. Step lamp | 9. Seat memory switch (if equipped) |

Removal

1. Remove power window switch assembly (if equipped).
 - Disconnect harness connectors.
2. Remove pull handle cover.
 - Remove screws behind pull handle cover.
3. Remove cap from pull handle escutcheon and remove screw.
4. Remove pull handle escutcheon.
 - Remove screws behind pull handle escutcheon.
5. Remove armrest.
 - Remove screw behind armrest.

DOOR FINISHER

6. Remove memory seat switch (if equipped).
 - Disconnect harness connector.
7. Remove step lamp.
 - Disconnect harness connector.
8. Remove door finisher and disconnect lock cable and handle cable from door handle assembly. Refer to [BL-130, "FRONT DOOR LOCK"](#).
9. Remove door lock knob.

Installation

Installation is in the reverse order of removal.

REAR DOOR - CREW CAB

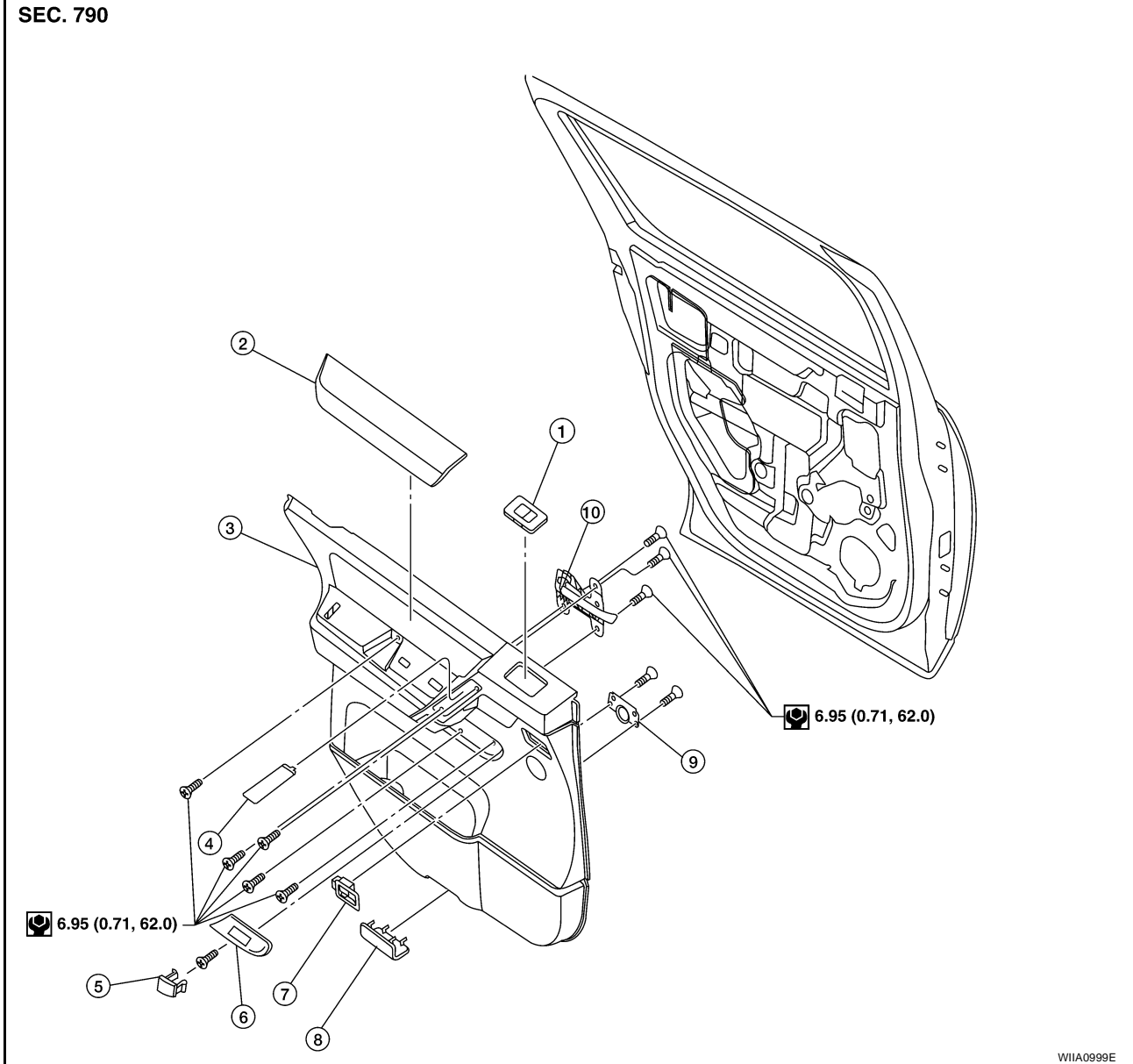

- | | | |
|---|--------------|---------------------------|
| 1. Power window switch assembly (if equipped) | 2. Armrest | 3. Rear door finisher LH |
| 4. Pull handle cover | 5. Cap | 6. Pull handle escutcheon |
| 7. Door lock knob | 8. Step lamp | 9. Rear door tweeter |

Removal

1. Remove power window switch assembly (if equipped).
 - Disconnect harness connector.

A
B
C
D
E
F
G
H
EI
J
K
L
M

DOOR FINISHER

2. Remove pull handle cover.
 - Remove screws behind pull handle cover.
3. Remove cap from pull handle escutcheon and remove screw.
4. Remove pull handle escutcheon.
 - Remove screws behind pull handle escutcheon.
5. Remove armrest.
 - Remove screws behind armrest.
6. Remove step lamp.
 - Disconnect harness connector.
7. Remove door finisher and disconnect lock cable and handle cable from door handle assembly. Refer to [BL-133, "REAR DOOR LOCK"](#).
 - Disconnect speaker connector.
8. Remove door lock knob.
9. Remove rear door tweeter.

Installation

Installation is in the reverse order of removal.

DOOR FINISHER

REAR DOOR - KING CAB

SEC. 790

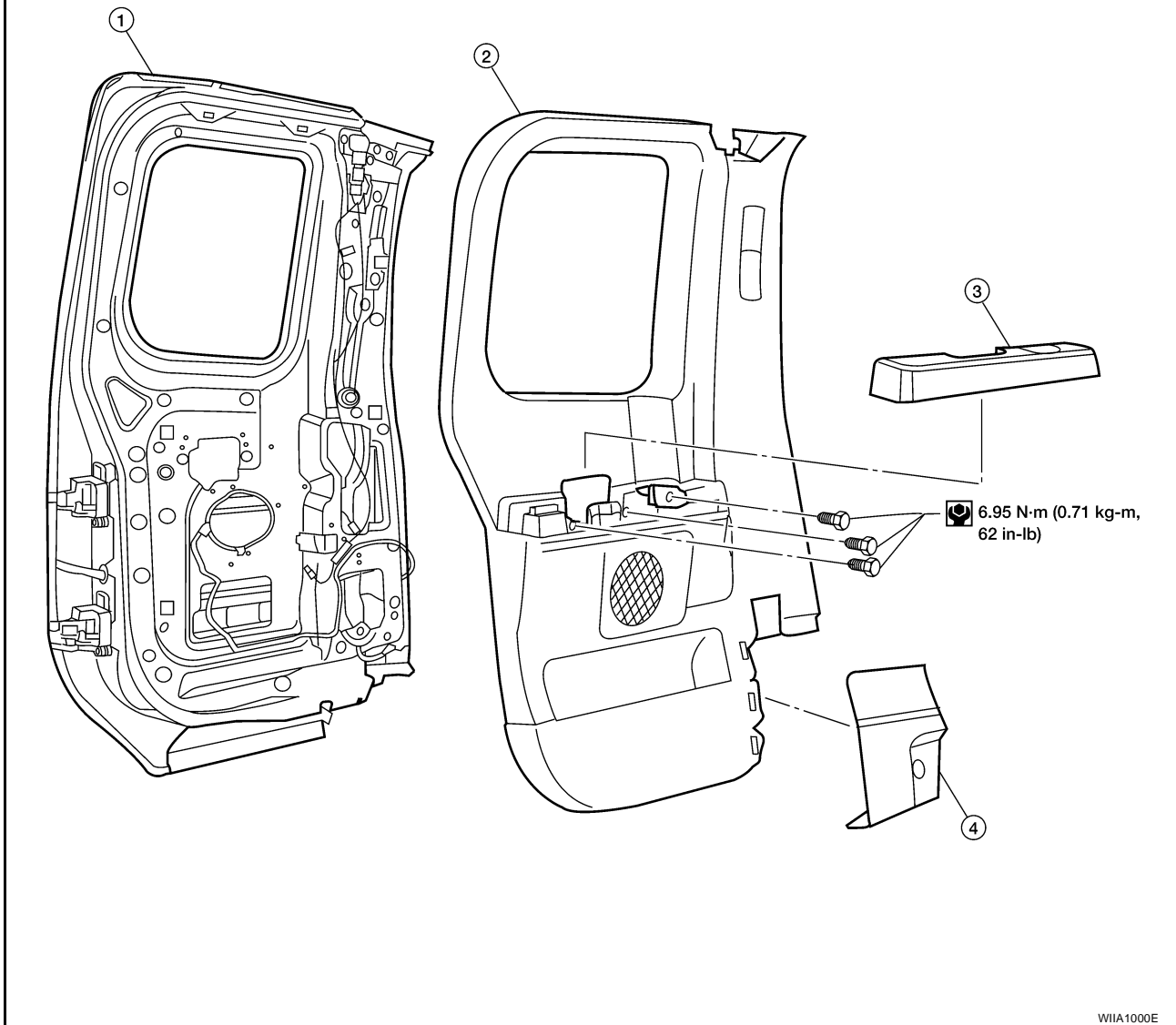

1. Rear door LH

2. Rear door finisher

3. Armrest

4. Seat belt retractor cover

Removal

1. Remove upper and lower seat belt anchor bolts. Refer to [SB-8, "Removal and Installation of Rear Seat Belt"](#).
2. Release clips and remove seat belt retractor cover.
3. Remove armrest.
4. Remove screws behind armrest.
5. Release clips and remove rear door finisher.

Installation

Installation is in the reverse order of removal.

BODY SIDE TRIM

BODY SIDE TRIM

PFP:76913

Removal and Installation KING CAB

EIS004EQ

CAUTION:

- Wrap the tip of flat-bladed screwdriver with a cloth when removing metal clips from finishers.
- When removing or installing body side welts, do not allow butyl seal to come in contact with pillar finisher.

SEC. 769

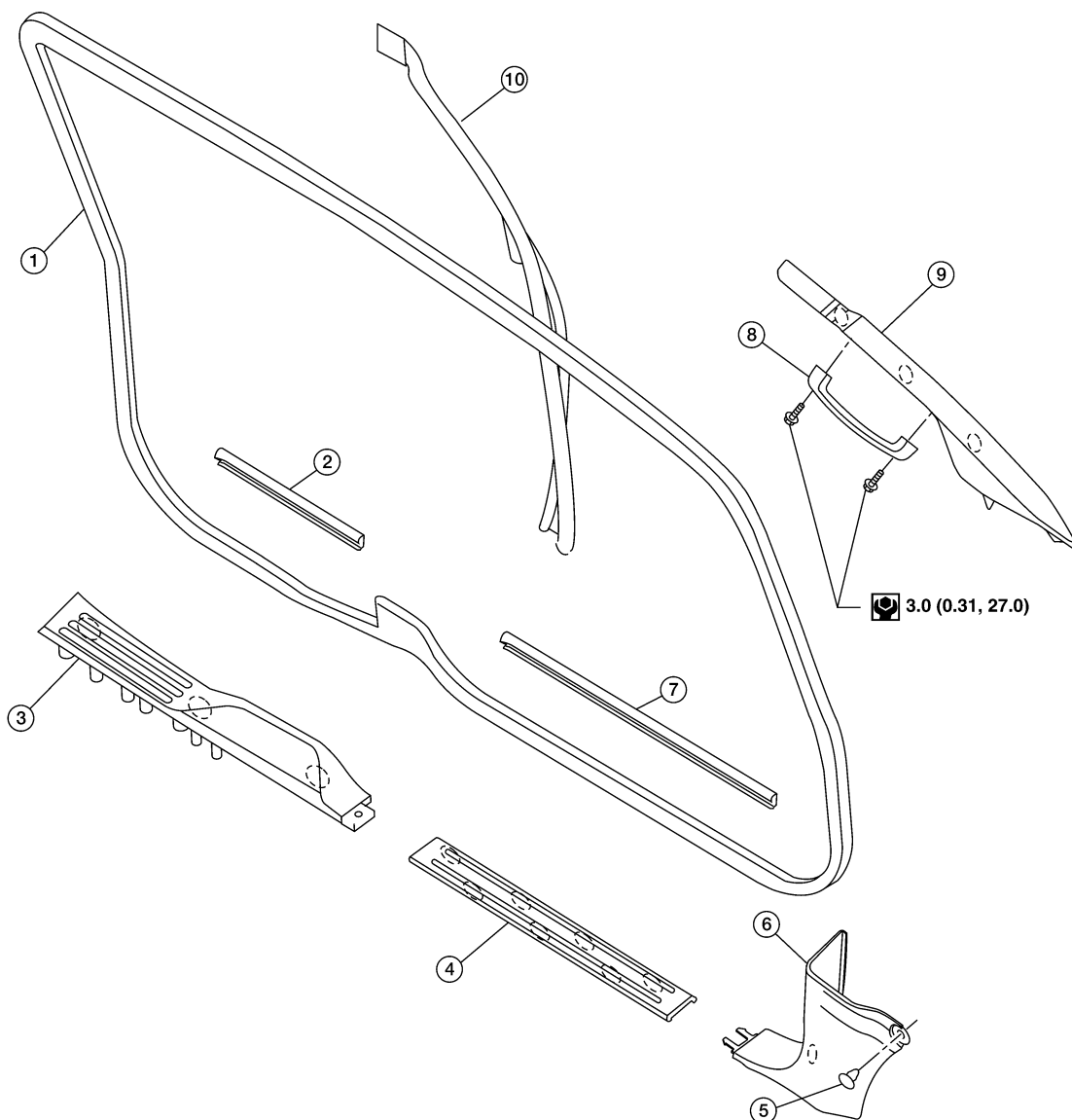

- | | | |
|----------------------------|-----------------------------|-----------------------------|
| 1. Door welt | 2. Rear door parting seal | 3. Rear kicking plate |
| 4. Front kicking plate | 5. Plastic clip C103 | 6. Lower dash side finisher |
| 7. Front door parting seal | 8. Front pillar assist grip | 9. Front pillar finisher |
| 10. Rear body side welt | | |

WIA1001E

BODY SIDE TRIM

CREW CAB

CAUTION:

- Wrap the tip of flat-bladed screwdriver with a cloth when removing metal clips from finishers.
- When removing or installing body side welts, do not allow butyl seal to come in contact with pillar finisher.

SEC. 769

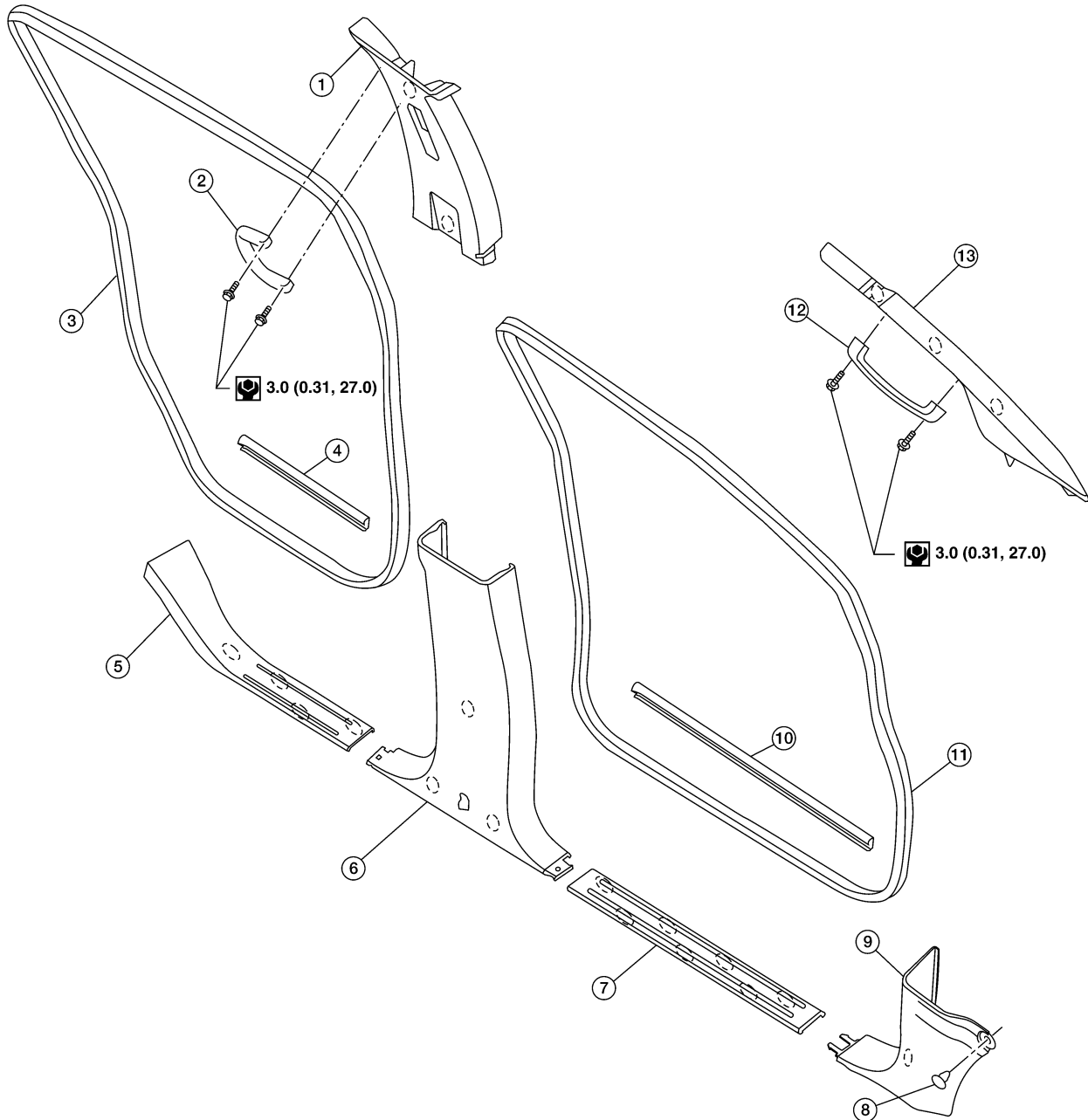

- | | | |
|---------------------------------|------------------------------|---------------------------------|
| 1. Center pillar upper finisher | 2. Center pillar assist grip | 3. Rear door welt |
| 4. Rear door parting seal | 5. Rear kicking plate | 6. Center pillar lower finisher |
| 7. Front kicking plate | 8. Plastic clip C103 | 9. Lower dash side finisher |
| 10. Front door parting seal | 11. Front door welt | 12. Front pillar assist grip |
| 13. Front pillar finisher | | |

WIIA1002E

BODY SIDE TRIM

LOWER DASH SIDE FINISHER

Removal

1. Remove push pin from lower dash side finisher.
2. Remove front kicking plate. Refer to [EI-38, "KICKING PLATES"](#).
3. Remove lower dash side finisher and front kicking plate together.
4. Remove lower dash side finisher from front kicking plate.

Installation

Installation is in the reverse order of removal.

CENTER PILLAR LOWER FINISHER

Removal

1. Remove seat belt lower anchor. Refer to [SB-3, "Removal and Installation of Front Seat Belt"](#).
 - On RH side, disconnect seat belt tension sensor.
2. Remove front and rear kicking plates. Refer to [EI-38, "KICKING PLATES"](#).
3. Remove center pillar lower finisher.

Installation

Installation is in the reverse order of removal.

CENTER PILLAR UPPER FINISHER

Removal

1. Remove front and rear door welts.
2. Remove front and rear kicking plates. Refer to [EI-38, "KICKING PLATES"](#).
3. Remove center pillar lower finisher. Refer to [EI-38, "CENTER PILLAR LOWER FINISHER"](#).
4. Remove seat belt shoulder anchor and D ring. Refer to [SB-3, "Removal and Installation of Front Seat Belt"](#).
5. Remove center pillar assist grip.
6. Remove center pillar upper finisher.

Installation

Installation is in the reverse order of removal.

FRONT PILLAR FINISHER

Removal

1. Remove front pillar assist grip.
2. Remove front pillar finisher.

Installation

Installation is in the reverse order of removal.

KICKING PLATES

Removal and Installation

Release clips and remove front and/or rear kicking plates.

Installation is in the reverse order of removal.

DOOR PARTING SEALS

Removal

1. Open front and/or rear doors fully.
2. Release clips and remove parting seals.

Installation

Installation is in the reverse order of removal.

BODY SIDE TRIM

REAR

CAUTION:

- Wrap the tip of flat-bladed screwdriver with a cloth when removing metal clips from finishers.

SEC. 769•799

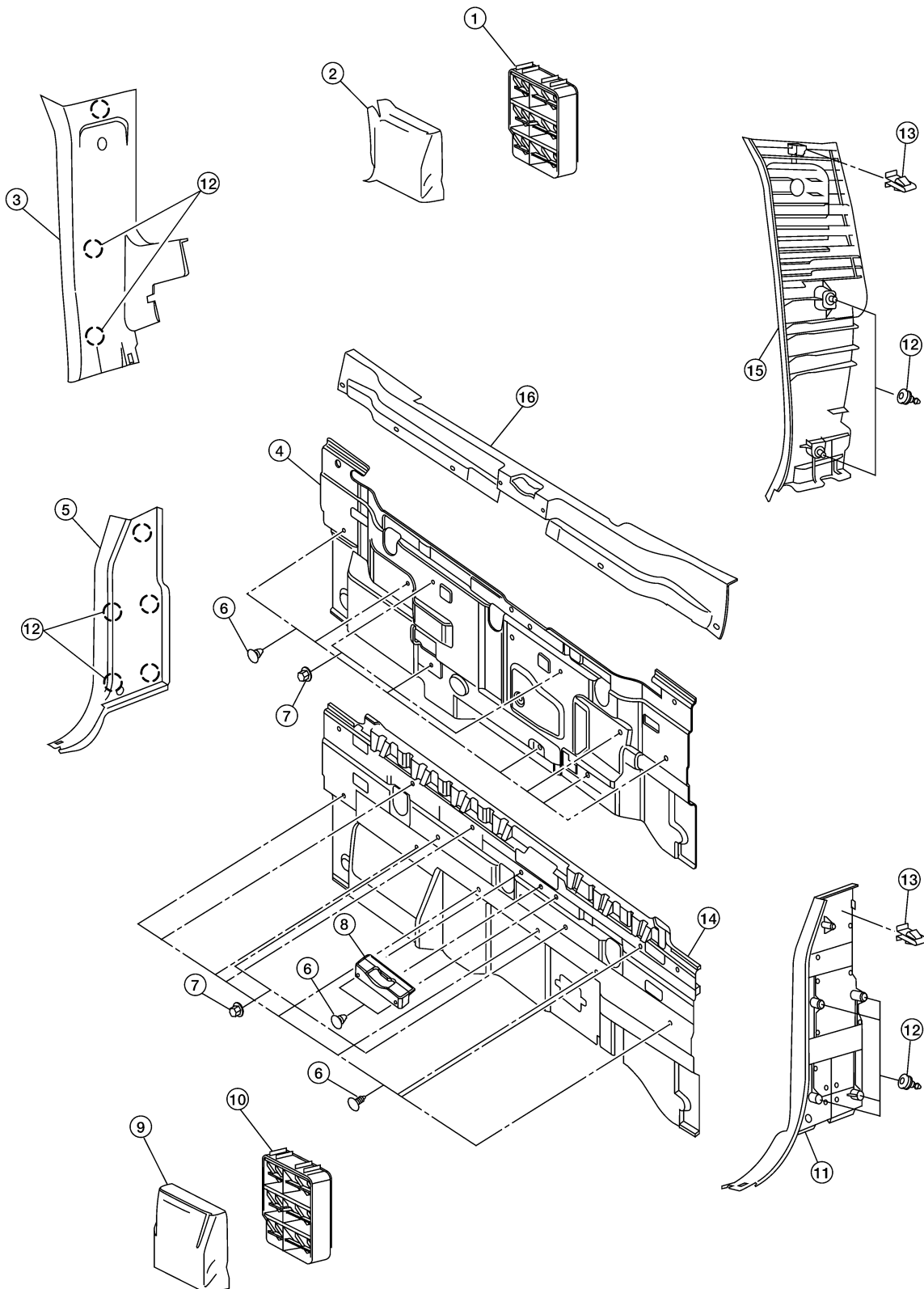

A
B
C
D
E
F
G
H
EI
J
K
L
M

BODY SIDE TRIM

- | | | |
|-------------------------------|----------------------------------|----------------------------------|
| 1. Drafter duct (Crew Cab) | 2. Drafter duct cover (Crew Cab) | 3. Rear upper finisher RH |
| 4. Rear panel (Crew Cab) | 5. Rear lower finisher RH | 6. Push pin |
| 7. Nut | 8. Center anchor bracket cover | 9. Drafter duct cover (King Cab) |
| 10. Drafter duct (King Cab) | 11. Rear lower finisher LH | 12. Plastic clip C101 |
| 13. Metal clip | 14. Rear panel (King Cab) | 15. Rear upper finisher LH |
| 16. Rear panel upper finisher | | |

Removal

1. Remove rear seats. Refer to [SE-97, "REAR SEAT"](#) .
2. Remove rear kicking plates. Refer to [EI-38, "KICKING PLATES"](#) .
3. Remove seat belt anchor bolts. Refer to [SB-8, "Removal and Installation of Rear Seat Belt"](#) .
4. Remove seatback latch strikers. Refer to [SE-97, "REAR SEAT"](#) .
5. Remove rear lower finishers LH/RH.
6. Remove rear upper finishers LH/RH.
7. Remove center anchor bracket cover, if equipped.
8. Remove rear panel upper finisher and rear panel.
9. Remove drafter duct cover and drafter duct.

Installation

Installation is in the reverse order of removal.

FLOOR TRIM

PFP:74902

EIS004ER

FLOOR TRIM

Removal and Installation

SEC. 749

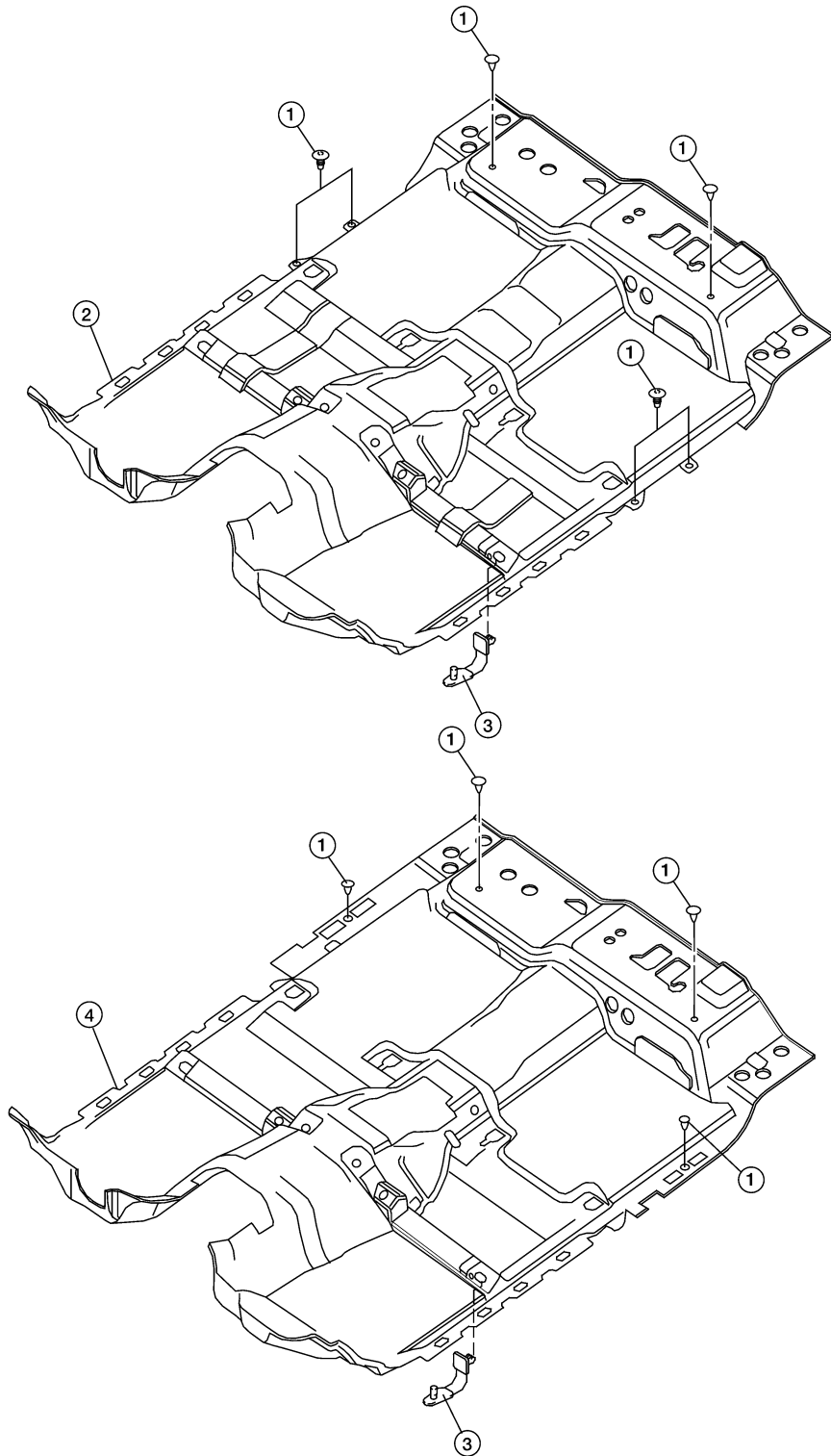

- 1. Push pin
- 4. Crew Cab carpet

- 2. King Cab carpet

- 3. Floor mat hook

WIA1004E

REMOVAL

1. Remove front seats. Refer to [SE-88, "FRONT SEAT"](#).

A
B
C
D
E
F
G
H
EI
J
K
L
M

FLOOR TRIM

2. Remove rear seats. Refer to [SE-97, "REAR SEAT"](#) .
3. Remove lower seat belt anchors. Refer to [SB-3, "SEAT BELTS"](#) .
4. Remove lower body side trim. Refer to [EI-36, "BODY SIDE TRIM"](#) .
5. Remove center console, if equipped. Refer to [IP-10, "INSTRUMENT PANEL ASSEMBLY"](#) .
6. Remove floor mat hooks from front carpet.
7. Remove carpet.

INSTALLATION

Installation is in the reverse order of removal.

HEADLINING

HEADLINING

PFP:73910

Removal and Installation

EIS004ES

A

B

C

D

E

F

G

H

EI

J

K

L

M

HEADLINING

Crew Cab

SEC. 738

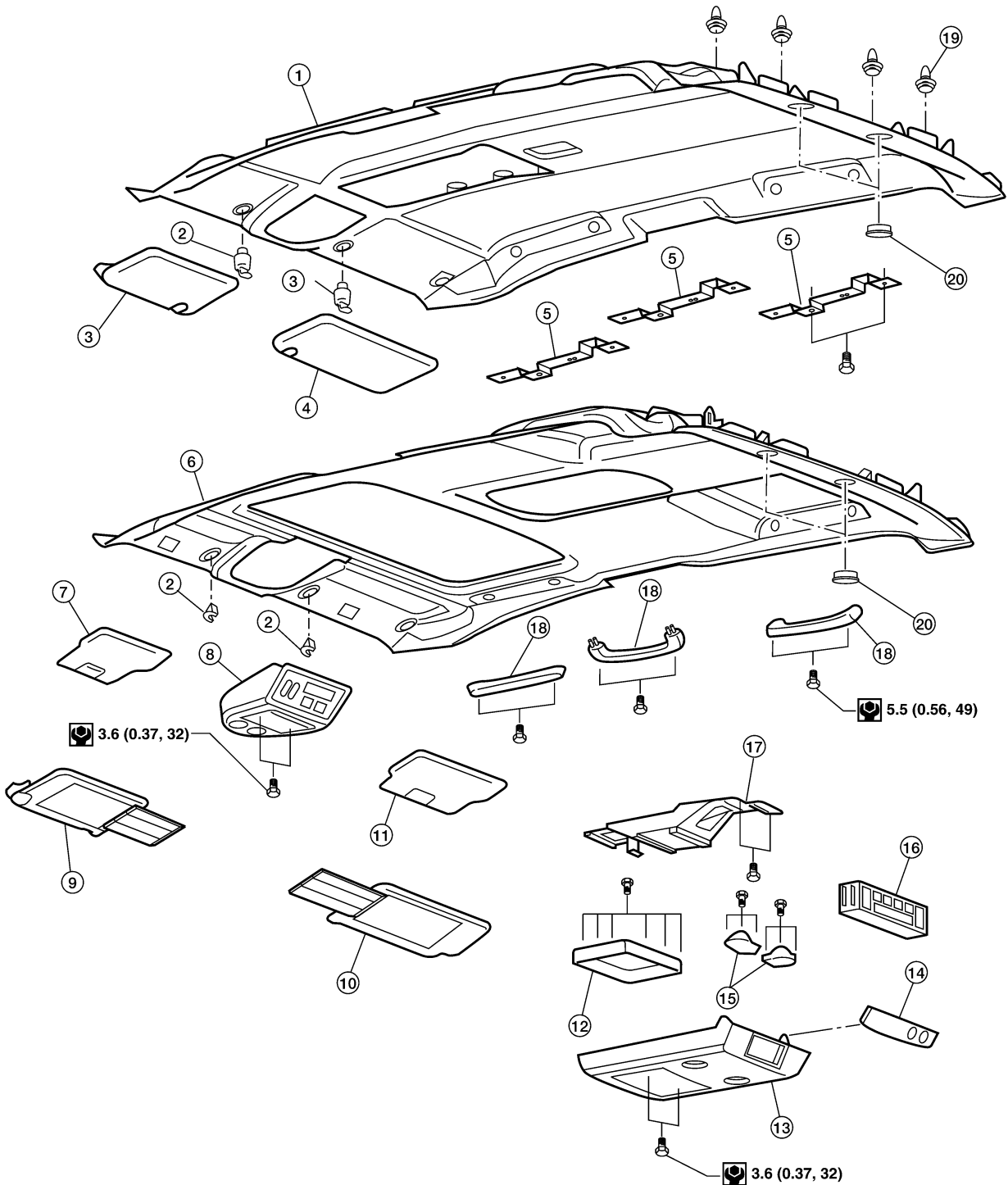

- | | | |
|----------------------------------|------------------------|----------------------------------|
| 1. Headlining (without sunroof) | 2. Sunvisor holder | 3. Sunvisor assembly standard LH |
| 4. Sunvisor assembly standard RH | 5. Assist grip bracket | 6. Headlining (with sunroof) |

WIHA1005E

HEADLINING

-
- | | | |
|---|---|-------------------------------------|
| 7. Dual sun visor assembly LH | 8. Front roof console | 9. Extended sun visor assembly LH |
| 10. Extended sun visor assembly RH | 11. Dual sun visor assembly RH | 12. Rear storage bin or DVD display |
| 13. Rear roof console | 14. Rear roof console finisher | 15. Lamp assembly |
| 16. Rear audio control assembly (if equipped) | 17. Rear roof console bracket | 18. Assist grip |
| 19. Room lamp | 20. High mounted stop lamp access cover | |

A

B

C

D

E

F

G

H

EI

J

K

L

M

HEADLINING

King Cab

SEC. 738

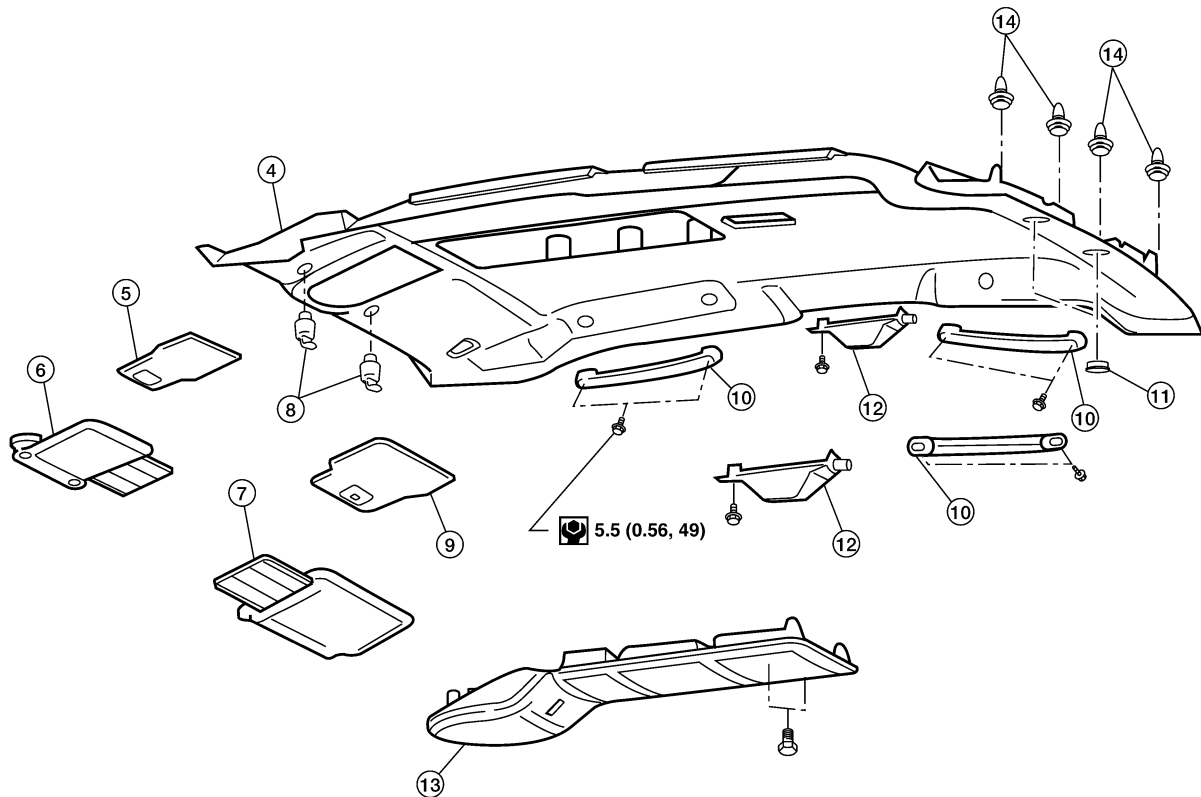
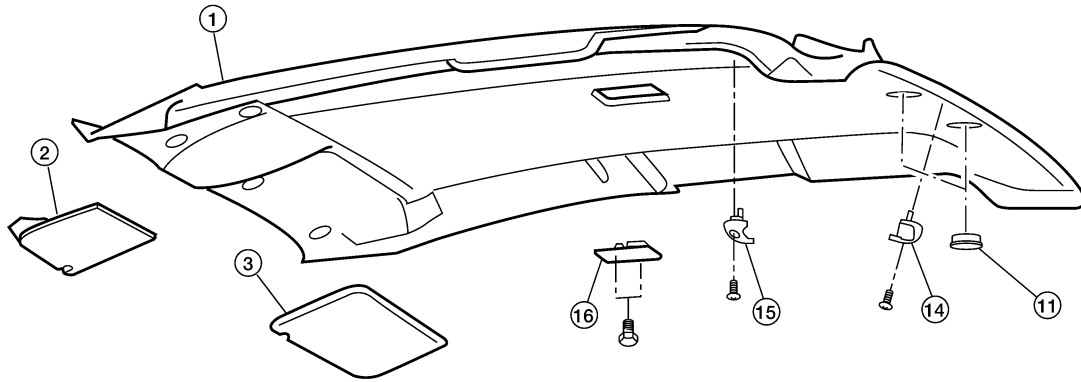

- 1. Headlining (standard)
- 4. Headlining (optional)

- 2. Sunvisor assembly standard LH
- 5. Dual sun visor assembly LH

- 3. Sunvisor assembly standard RH
- 6. Extended sun visor assembly LH

WIIA1006E

HEADLINING

-
- | | | |
|-----------------------------------|------------------------|-------------------------------|
| 7. Extended sun visor assembly RH | 8. Sunvisor holder | 9. Dual sun visor assembly RH |
| 10. Assist grip | 11. CHMSL access cover | 12. Striker cover |
| 13. Center roof console | 14. Plastic clip | 15. Coat hook |
| 16. Room lamp | | |

A

B

REMOVAL

CAUTION:

Disconnect both terminals from battery in advance.

C

1. Remove body side trim. Refer to [EI-36, "BODY SIDE TRIM"](#) .
2. Remove rear trim. Refer to [EI-36, "BODY SIDE TRIM"](#) .
3. Remove sun visor assemblies.
4. Remove sun visor holders.
5. Remove front roof console (if equipped).
 - Disconnect harnesses.
6. Remove rear roof console (if equipped).
 - Disconnect harnesses.
7. Remove center roof console (if equipped).
 - Disconnect harnesses.
8. Remove assist grips.
9. Remove striker covers (if equipped).
10. Remove room lamp.
11. Remove headlining.
 - Disconnect harnesses.
12. Remove rear audio control assembly from rear roof console (if equipped).
 - Disconnect harness.
13. Remove lamp assemblies from roof console.
 - Disconnect harnesses.
14. Remove rear roof console bracket (if equipped).
15. Remove center roof console front bracket (if equipped).
16. Remove assist grip brackets from roof (if equipped).

D

E

F

G

H

EI

J

K

INSTALLATION

Installation is in the reverse order of removal.

L

M

BED RAILS AND TRIM

BED RAILS AND TRIM Removal and Installation

PFP:84999

EIS004ET

SEC. 932 • 935 • 937

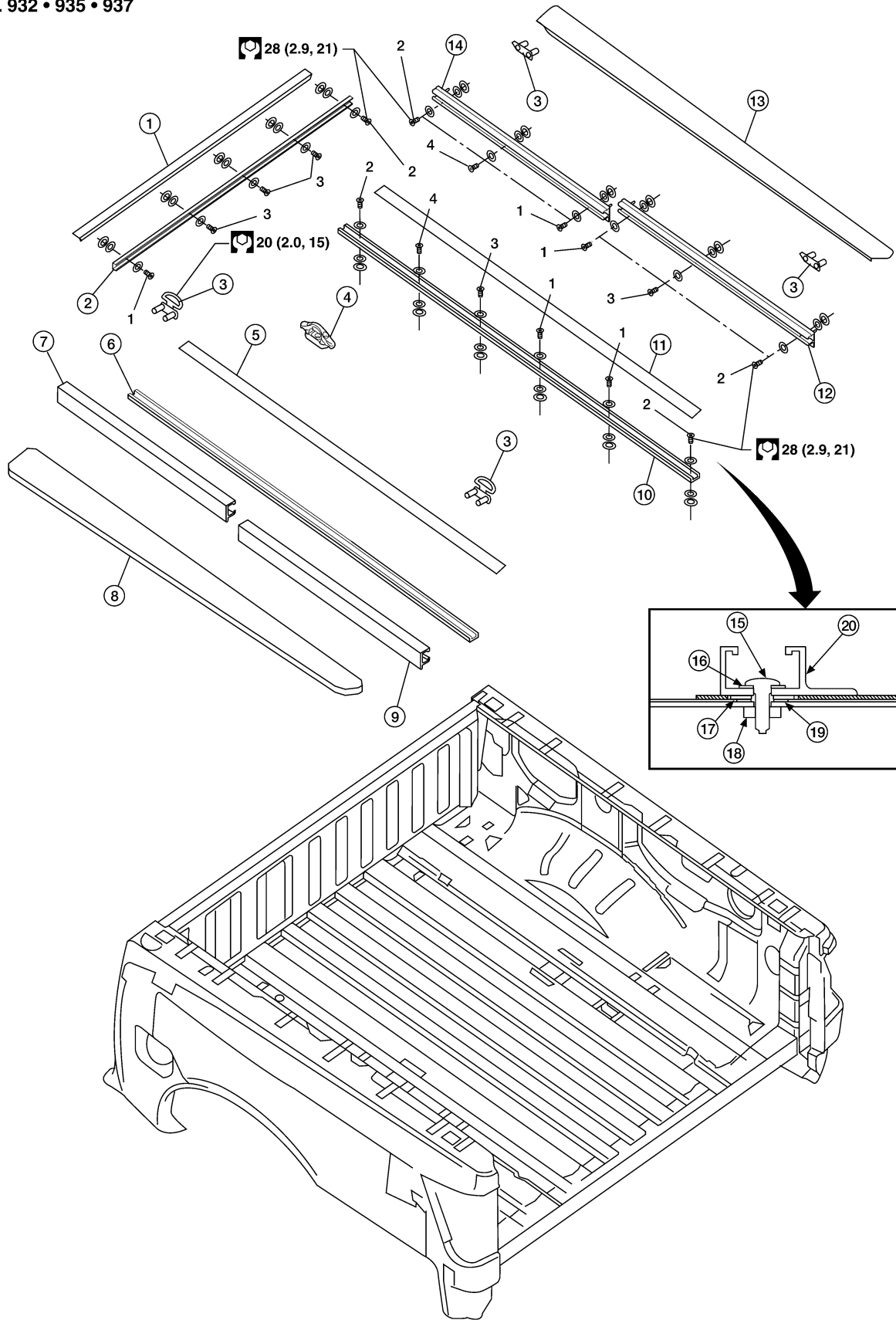

WIA1007E

BED RAILS AND TRIM

-
- | | | | |
|------------------------------------|-------------------------------------|------------------------------------|---|
| 1. Header top trim | 2. Header tie down rail | 3. Rope hook | A |
| 4. Tie down cleat | 5. Floor rail cover LH | 6. Floor rail LH | |
| 7. Bed side front tie down rail LH | 8. Top side rail trim LH | 9. Bed side rear tie down rail LH | |
| 10. Floor rail RH | 11. Floor rail cover RH | 12. Bed side rear tie down rail RH | B |
| 13. Top side rail trim RH | 14. Bed side front tie down rail RH | 15. Bolt | |
| 16. Washer | 17. Spacer | 18. Weld nut | |
| 19. Plastic keeper | 20. Rail | | C |

REMOVAL

1. Remove floor rail covers.
2. Remove tie down cleats.
3. Remove floor rails LH/RH.
4. Remove bed side front and rear tie down rails LH/RH.
5. Remove rope hooks.
6. Remove header tie down rail.
7. Release clips and remove header top trim.
8. Release clips and remove top side rail trim LH/RH.

INSTALLATION

Installation is in the reverse order of removal.

NOTE:

Tighten rail bolts in numerical order.

A
B
C
D
E
F
G
H
I
J
K
L
M

EI

TAIL GATE FINISHER

PFP:93486

EIS004EU

TAIL GATE FINISHER Removal and Installation

SEC. 940

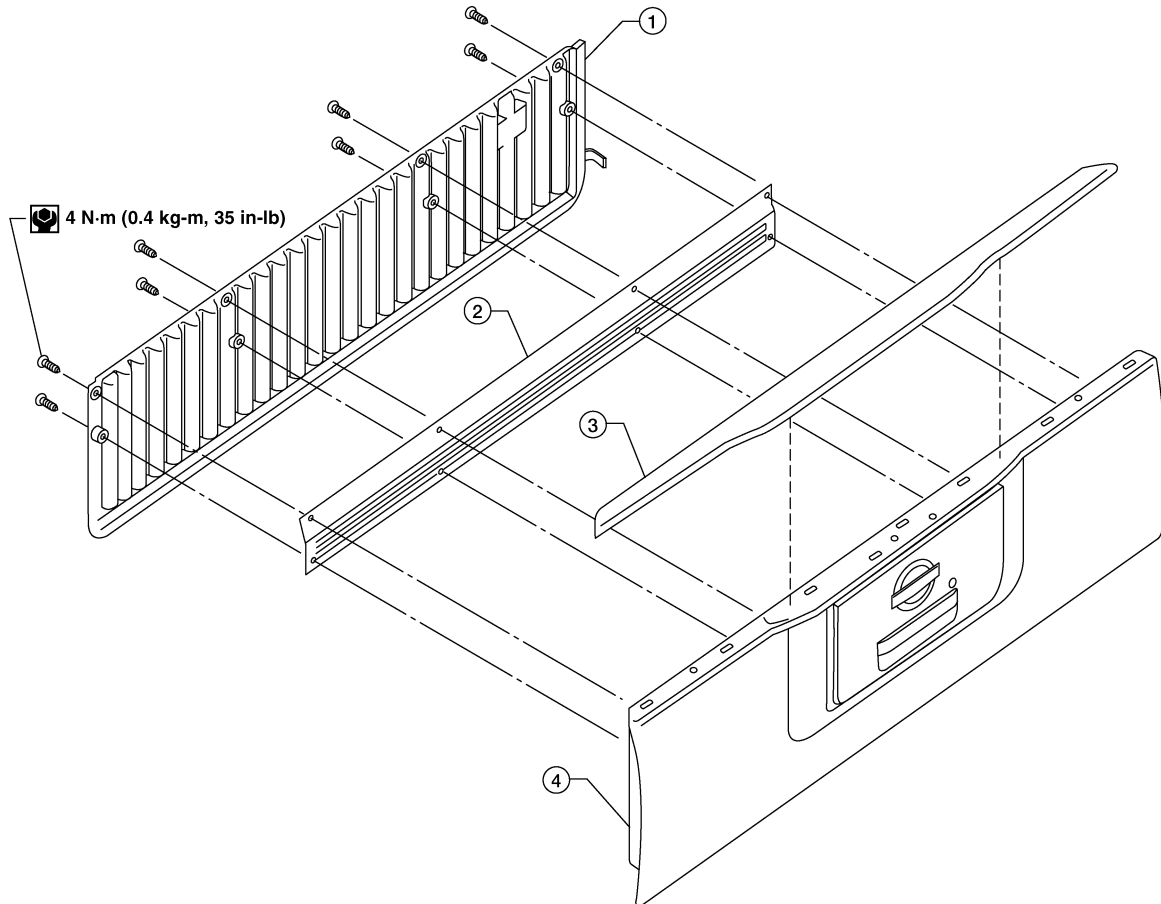

1. Tailgate protector (if equipped) 2. Tailgate cover plate 3. Tailgate top protector
4. Tailgate assembly

LIA1238E

REMOVAL

1. Release clips and remove tailgate top protector.
2. Remove screws and remove tailgate protector (if equipped) and tailgate cover plate.

INSTALLATION

Installation is in the reverse order of removal.

STORAGE BOX

PFP:97002

EIS004EV

STORAGE BOX

Removal and Installation

SEC. 935

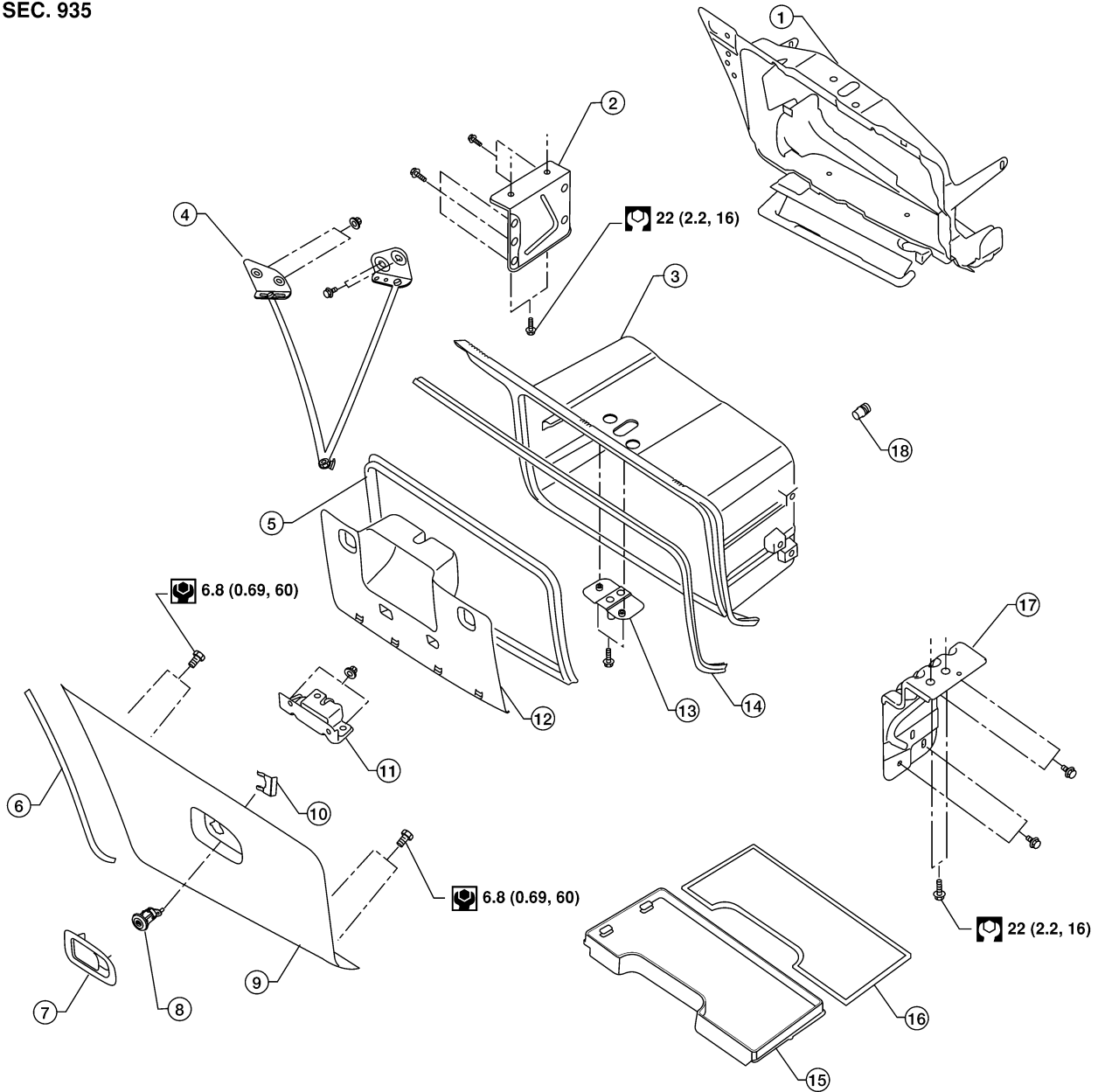

N-m (kg-m, in-lb)

N-m (kg-m, ft-lb)

- | | | |
|------------------------------|------------------------|----------------------|
| 1. Surround assembly | 2. Front outer bracket | 3. Storage box |
| 4. Door stay assembly | 5. Bulb seal | 6. Outer seal |
| 7. Key cylinder lid assembly | 8. Key cylinder | 9. Storage box door |
| 10. Key cylinder retainer | 11. Latch assembly | 12. Inner door cover |
| 13. Striker | 14. Door seal | 15. Shelf bin |
| 16. Shelf bin mat | 17. Rear outer bracket | 18. Back stop |

WI1A0352E

REMOVAL

1. Remove rear mudguard (if equipped). Refer to [EI-27, "MUDGUARD"](#).
2. Remove bolts, release clips and remove storage box assembly.
3. Remove shelf bin and mat from storage box.

STORAGE BOX

4. Remove storage box door from hinge.
 - Remove door stay assembly.
5. Remove inner door cover.
6. Remove nuts and remove latch assembly from door.
 - Remove key cylinder.
7. Remove outer seal and key cylinder lid assembly from door.
8. Remove bulb seal and door seal from storage box.
9. Remove storage box from surround assembly.

INSTALLATION

Installation is in the reverse order of removal.