

A
B
C
D

WT

SECTION

ROAD WHEELS & TIRES

WT

CONTENTS

PREPARATION	2		
Special Service Tool	2	How to Perform Trouble Diagnosis for Quick and	
Commercial Service Tools	2	Accurate Repair	19
NOISE, VIBRATION, AND HARSHNESS (NVH)		INTRODUCTION	19
TROUBLESHOOTING	3	WORK FLOW	19
NVH Troubleshooting Chart	3	Preliminary Check	20
WHEEL	4	Malfunction Code/Symptom Chart	21
Inspection	4	TROUBLE DIAGNOSIS FOR SELF-DIAGNOSTIC	
WHEEL AND TIRE ASSEMBLY	5	ITEMS	23
Balancing Wheels	5	Inspection 1: Transmitter or Control Unit (BCM)	23
REMOVAL	5	MALFUNCTION CODE NO. 21, 22, 23 OR 24 ...	23
WHEEL BALANCE ADJUSTMENT	5	Inspection 2: Transmitter - 1	23
Rotation	6	MALFUNCTION CODE NO. 31, 32, 33, 34, 41,	
LOW TIRE PRESSURE WARNING SYSTEM	7	42, 43, 44, 45, 46, 47 OR 48	23
System Components	7	Inspection 3: Transmitter - 2	24
System Description	7	MALFUNCTION CODE NO. 35, 36, 37 OR 38 ...	24
TRANSMITTER	7	Inspection 4: Vehicle Speed Signal	25
REMOTE KEYLESS ENTRY RECEIVER	7	MALFUNCTION CODE NO. 52	25
BCM (BODY CONTROL MODULE)	8	TROUBLE DIAGNOSIS FOR SYMPTOMS	26
WARNING LAMP AND BUZZER	8	Inspection 1: Warning Lamp Does Not Come On	
DISPLAY UNIT (WITH NAVI)	8	When Ignition Switch Is Turned On	26
CAN COMMUNICATION	9	Inspection 2: Warning Lamp Stays On When Ignition	
System Description	9	Switch Is Turned On	26
TROUBLE DIAGNOSES	10	Inspection 3: Warning Lamp Flashes When Ignition	
Wiring Diagram	10	Switch Is Turned On	28
Control Unit Input/Output Signal Standard	12	Inspection 4: Hazard Warning Lamp Flashes When	
ID Registration Procedure	13	Ignition Switch Is Turned On	29
ID REGISTRATION WITH TRANSMITTER		Inspection 5: "TIRE PRESSURE" Information In	
ACTIVATION TOOL	13	Display Unit Does Not Exist	30
ID REGISTRATION WITHOUT TRANSMITTER		Inspection 6: ID Registration Cannot Be Completed..	30
ACTIVATION TOOL	14	REMOVAL AND INSTALLATION	31
Transmitter Wake Up Operation	15	Transmitter (Pressure Sensor)	31
WITH TRANSMITTER ACTIVATION TOOL	15	REMOVAL	31
CONSULT-II Function (BCM)	16	INSTALLATION	31
Self-Diagnosis	17	SERVICE DATA AND SPECIFICATIONS (SDS)	33
DESCRIPTION	17	Road Wheel	33
FUNCTION	17	Tire	33

PREPARATION

PREPARATION

PFP:00002

Special Service Tool

EES001D2

The actual shapes of Kent-Moore tools may differ from those of special service tools illustrated here.

Tool number (Kent-Moore No.) Tool name	Description
— (J-45295) Transmitter activation tool	ID registration

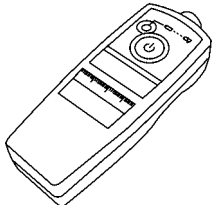

LEIA0035E

Commercial Service Tools

EES001D3

Tool name	Description
Power tool	Removing wheel nuts

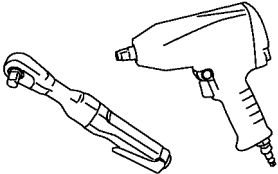

PBIC0190E

NOISE, VIBRATION, AND HARSHNESS (NVH) TROUBLESHOOTING

NOISE, VIBRATION, AND HARSHNESS (NVH) TROUBLESHOOTING

PFP:00003

NVH Troubleshooting Chart

EES001D4

Use the chart below to help you find the cause of the symptom. If necessary, repair or replace these parts.

Reference page		WT-4	WT-5	WT-33	WT-6	—	—	WT-33	FFD-7, "NVH Troubleshooting Chart" (FFD) , RFD-8, "NVH Troubleshooting Chart" (RFD)	FAX-4, "NVH Troubleshooting Chart" (FAX) , FSU-4, "NVH Troubleshooting Chart" (FSU)	RAX-4, "NVH Troubleshooting Chart" (RAX) , RSU-4, "NVH Troubleshooting Chart" (RSU)	Refer to TIRES in this chart.	Refer to ROAD WHEEL in this chart.	BR-5, "NVH Troubleshooting Chart"	PS-5, "NVH Troubleshooting Chart"	
Possible cause and SUSPECTED PARTS		Out-of-round	Imbalance	Incorrect tire pressure	Uneven tire wear	Deformation or damage	Non-uniformity	Incorrect tire size	DIFFERENTIAL	FRONT AXLE AND FRONT SUSPENSION	REAR AXLE AND REAR SUSPENSION	TIRES	ROAD WHEEL	BRAKE	STEERING	
Symptom	TIRES	Noise	x	x	x	x	x	x	x	x	x	x	x	x	x	
		Shake	x	x	x	x	x	x	x	x	x	x	x	x	x	x
		Vibration			x				x		x	x	x			x
		Shimmy	x	x	x	x	x	x	x		x	x	x	x	x	x
		Shudder	x	x	x	x	x		x		x	x	x		x	x
		Poor quality ride or handling	x	x	x	x	x		x		x	x	x			
	ROAD WHEEL	Noise	x	x			x			x	x	x	x	x	x	x
		Shake	x	x			x				x	x	x	x	x	x
Shimmy, shudder		x	x			x				x	x	x	x	x	x	
Poor quality ride or handling		x	x			x				x	x	x				

x: Applicable

A
B
C
D
E
F
G
H
I
J
K
L
M

WT

WHEEL

WHEEL

PPF:40300

Inspection

EES001D5

1. Check tires for wear and improper inflation.
2. Check wheels for deformation, cracks and other damage. If deformed, remove wheel and check wheel runout.
 - a. Remove tire from wheel and mount wheel on a tire balance machine.
 - b. Set dial indicator as shown in the illustration. Refer to [WT-33, "Road Wheel"](#).
3. Check front wheel bearings for looseness.
4. Check front suspension for looseness.

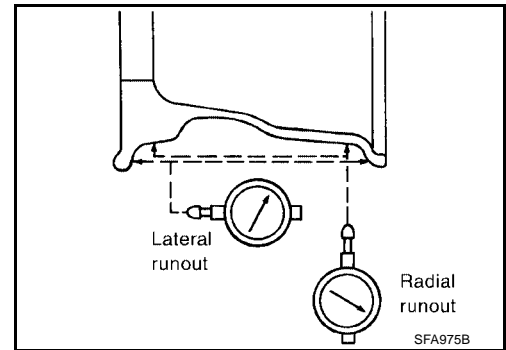

WHEEL AND TIRE ASSEMBLY

PF:40300

WHEEL AND TIRE ASSEMBLY

Balancing Wheels REMOVAL

EES001D6

1. Remove inner and outer balance weights from the wheel.

CAUTION:

Be careful not to scratch the wheel during removal.

2. Using releasing agent, remove double-faced adhesive tape from the wheel.

CAUTION:

After removing double-faced adhesive tape, wipe clean traces of releasing agent from the wheel.

WHEEL BALANCE ADJUSTMENT

- If a tire balance machine has adhesion balance weight mode settings and drive-in weight mode setting, select and adjust a drive-in weight mode suitable for wheels.

1. Set wheel on wheel balancer using the center hole as a guide. Start the tire balance machine.
2. When inner and outer imbalance values are shown on the wheel balancer indicator, multiply outer imbalance value by 1.6 to determine balance weight that should be used. Select the outer balance weight with a value closest to the calculated value and install it to the designated outer position of, or at the designated angle in relation to the road wheel.

CAUTION:

- **Do not install the inner balance weight before installing the outer balance weight.**
- **Before installing the balance weight, be sure to clean the mating surface of the wheel.**

Indicated imbalance value $\times 5/3 =$ balance weight to be installed
Calculation example:

$23 \text{ g (0.81 oz)} \times 5/3 = 38.33 \text{ g (1.35 oz)} = 40 \text{ g (1.41 oz)}$ balance weight (closer to calculated balance weight value)

Note that balance weight value must be closer to the calculated balance weight value.

Example:

$37.4 \text{ g} = 35 \text{ g (1.23 oz)}$

$37.5 \text{ g} = 40 \text{ g (1.41 oz)}$

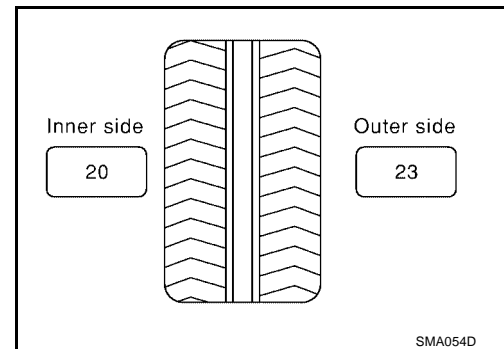

- a. Install balance weight in the position shown.
- b. When installing balance weight to wheels, set it into the grooved area on the inner wall of the wheel as shown so that the balance weight center is aligned with the wheel balancer indication position (angle).

CAUTION:

- **Always use Genuine NISSAN adhesion balance weights.**
- **Balance weights are not reusable; always replace with new ones.**
- **Do not install more than three sheets of balance weights.**

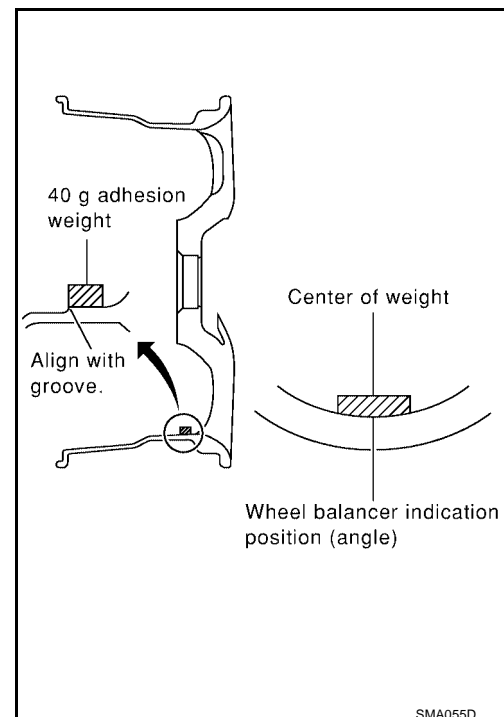

A
B
C
D
WT
F
G
H
I
J
K
L
M

WHEEL AND TIRE ASSEMBLY

- c. If calculated balance weight value exceeds 50 g (1.76 oz), install two balance weight sheets in line with each other as shown.

CAUTION:

Do not install one balance weight sheet on top of another.

3. Start wheel balancer again.
 4. Install drive-in balance weight on inner side of road wheel in the wheel balancer indication position (angle).

CAUTION:

Do not install more than two balance weights.

5. Start wheel balancer. Make sure that inner and outer residual imbalance values are 5 g (0.18 oz) each or below.

- If either residual imbalance value exceeds 5 g (0.18 oz), repeat installation procedures.

Wheel balance (Maximum allowable imbalance):

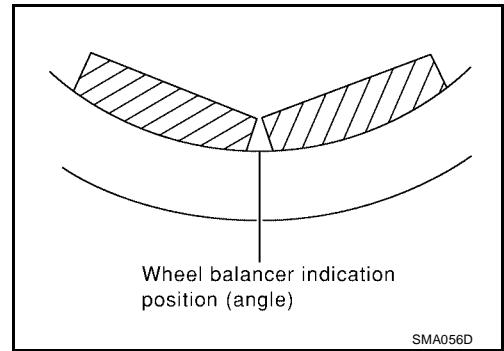

Maximum allowable imbalance	Dynamic (At rim flange)	5 g (0.18 oz) (one side)
	Static	10 g (0.35 oz)

Rotation

EES001PX

NOTE:

Follow the maintenance schedule for tire rotation service intervals. Refer to [MA-7, "PERIODIC MAINTENANCE"](#).

1. Rotate the tires on each side from front to back as shown. Do not include the spare tire when rotating the tires.

Wheel nut torque : 133 N·m (14 kg-m, 98 ft-lb)

CAUTION:

When installing wheels, tighten them diagonally by dividing the work two to three times in order to prevent the wheels from developing any distortion.

2. Adjust the tire pressure to specification. Refer to [WT-33, "Tire"](#).
 3. After the tire rotation, retighten the wheel nuts after the vehicle has been driven for 1,000 km (600 miles), and also after every wheel and tire have been installed such as after repairing a flat tire.

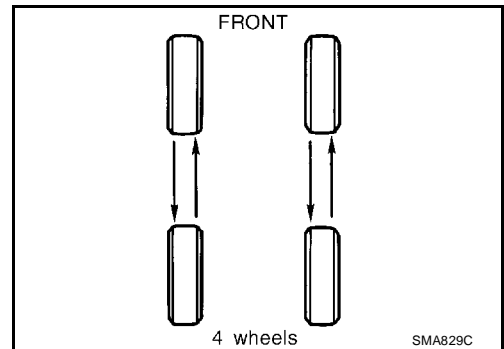

LOW TIRE PRESSURE WARNING SYSTEM

LOW TIRE PRESSURE WARNING SYSTEM

PF:40300

System Components

EES001D8

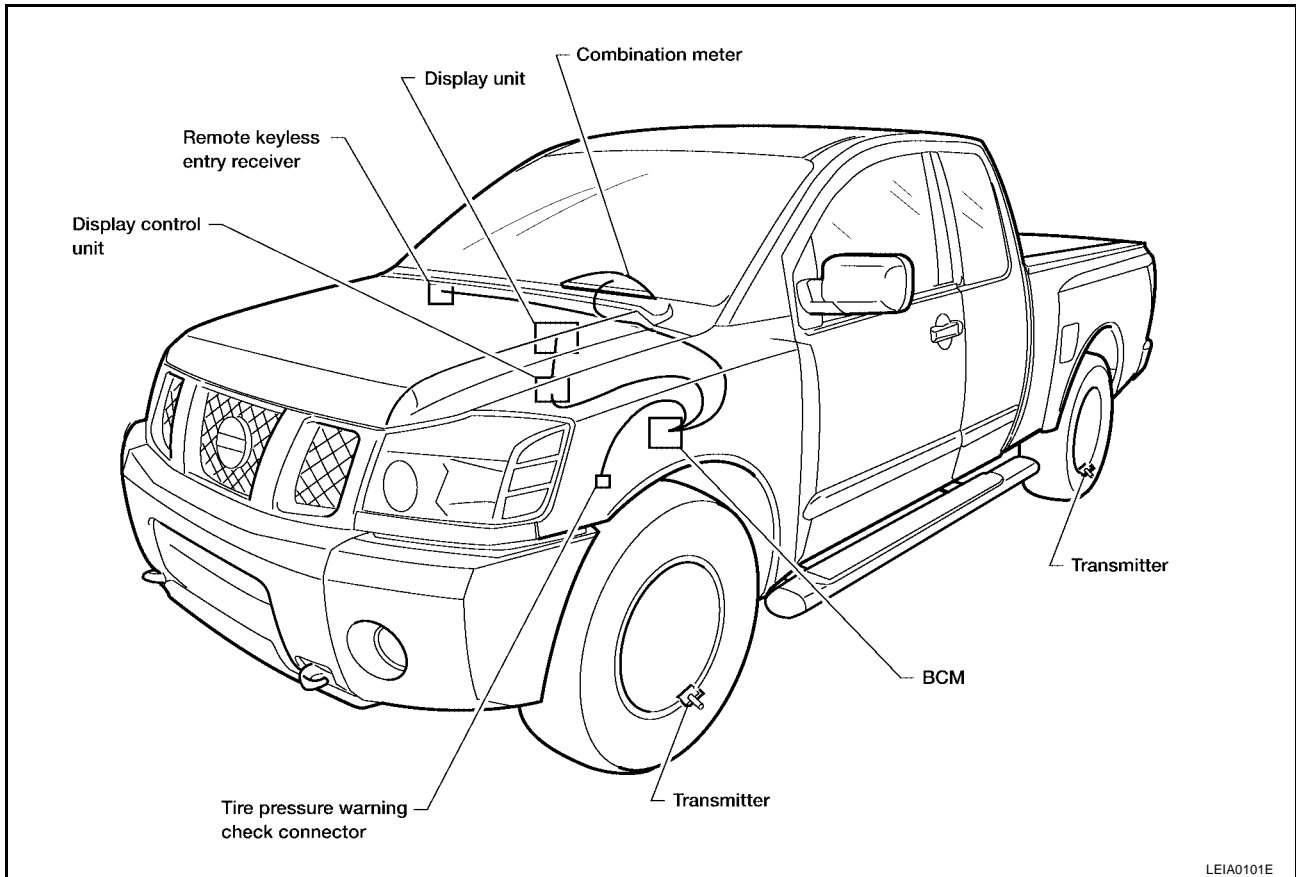

LEIA0101E

System Description

TRANSMITTER

EES001D9

A sensor-transmitter integrated with a valve is installed on a wheel, and transmits a detected air pressure signal in the form of a radio wave.

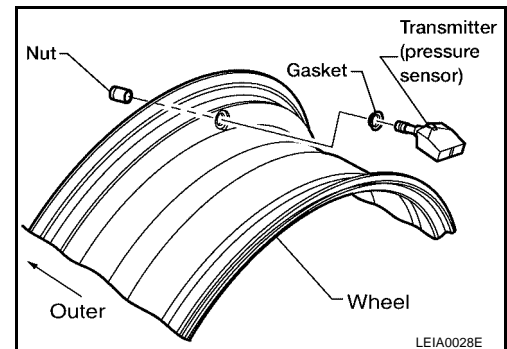

LEIA0028E

REMOTE KEYLESS ENTRY RECEIVER

Receives the air pressure signal transmitted by the transmitter in each wheel.

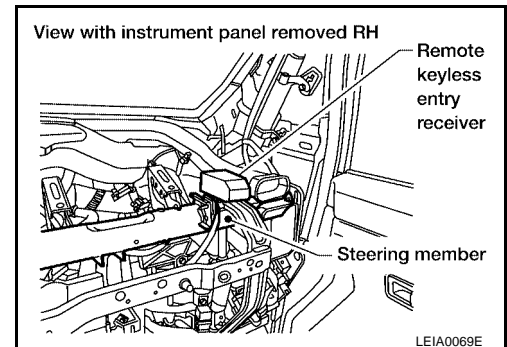

LEIA0069E

A
B
C
D
WT
F
G
H
I
J
K
L
M

LOW TIRE PRESSURE WARNING SYSTEM

BCM (BODY CONTROL MODULE)

Reads the air pressure signal received by the remote keyless entry receiver, and controls the warning lamp and the buzzer operations as shown below. It also has a judgement function to detect a system malfunction.

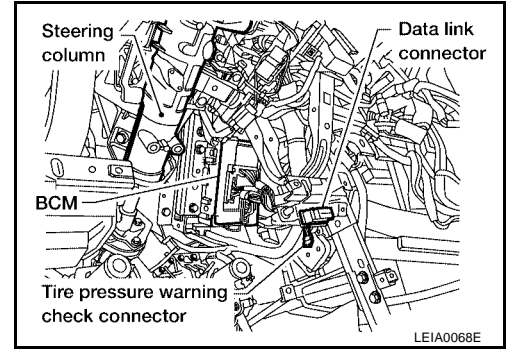

WARNING LAMP AND BUZZER

Indicates low tire pressure or system malfunction.

Condition	Warning lamp	Buzzer
Less than 193 kPa (2.0 kg/cm ² , 28 psi) [Flat tire]	ON	Sounds for 10 sec.
System malfunction	ON	OFF

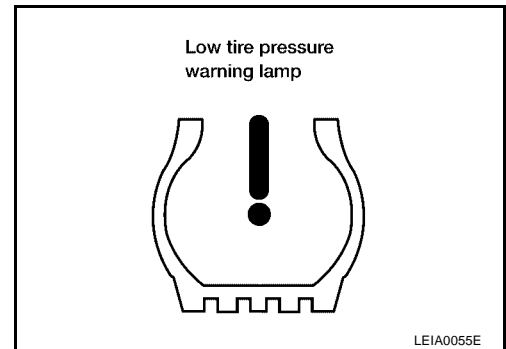

DISPLAY UNIT (WITH NAVI)

Displays the air pressure of each tire.

- After the ignition switch is turned on, the pressure values will not be displayed until the data of each wheel is received.

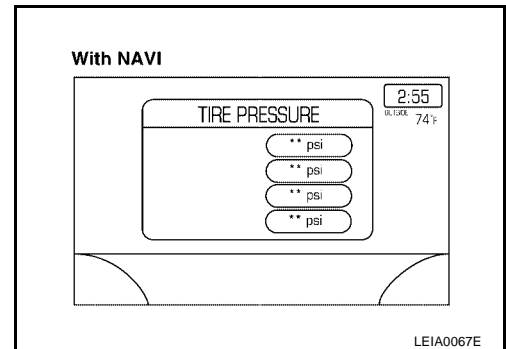

CAN COMMUNICATION

CAN COMMUNICATION

PFP:23710

System Description

EES001DA

Refer to [LAN-7, "CAN COMMUNICATION"](#) .

A

B

C

D

WT

F

G

H

I

J

K

L

M

TROUBLE DIAGNOSES

WT-T/WARN-02

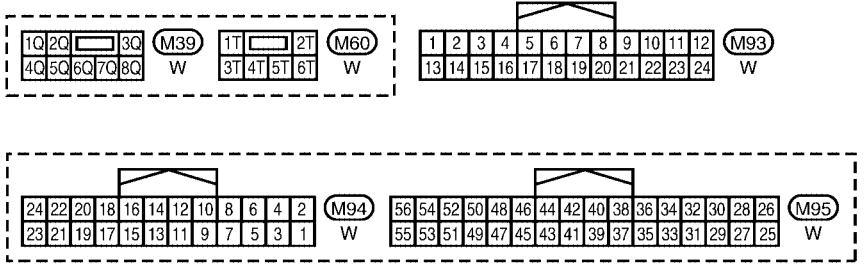
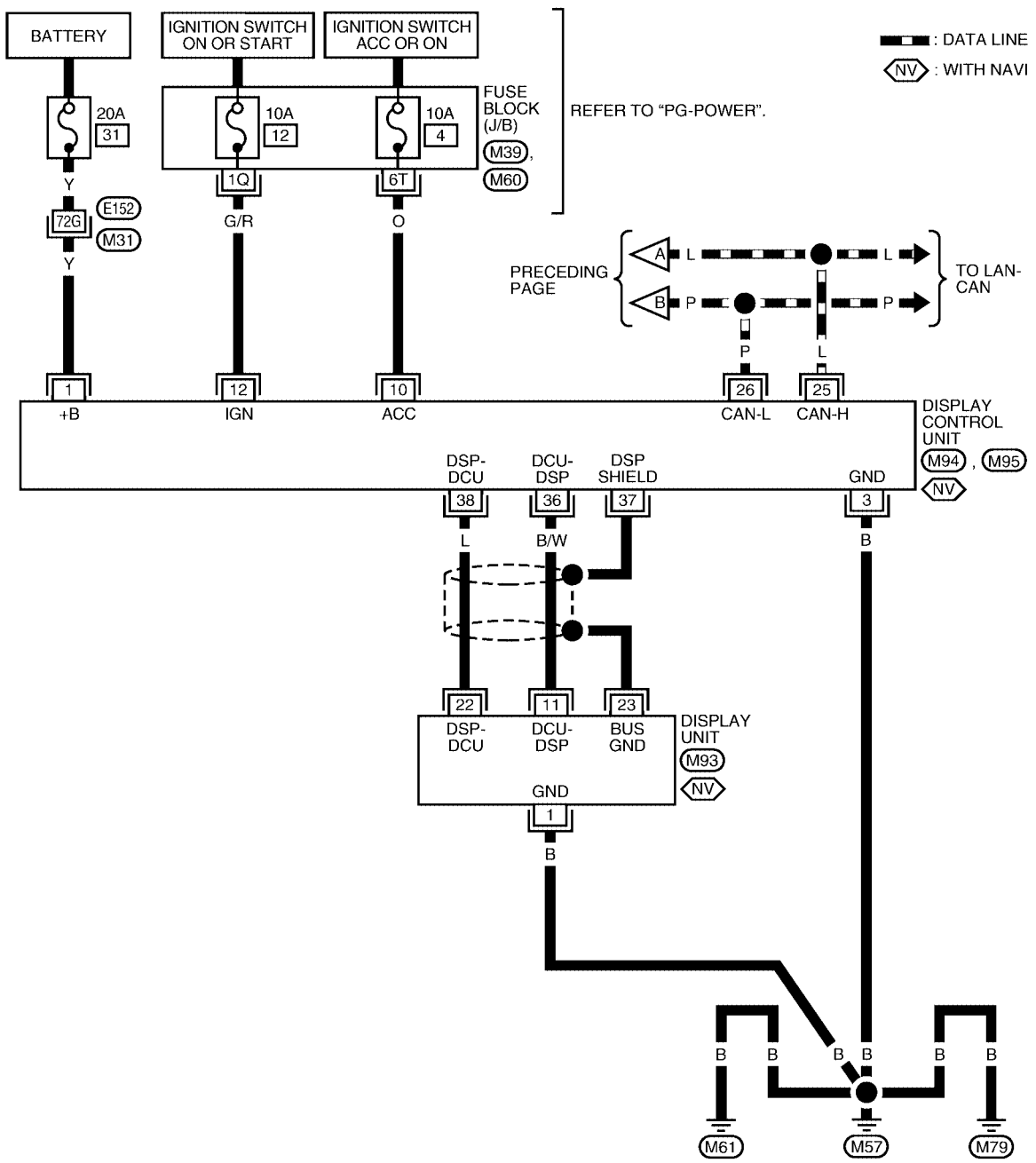

REFER TO THE FOLLOWING.
 (M31) - SUPER MULTIPLE JUNCTION (SMJ)

WEWA0031E

TROUBLE DIAGNOSES

Control Unit Input/Output Signal Standard

EES001DC

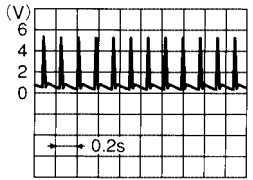
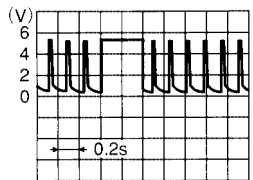
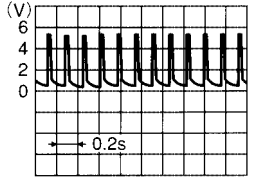
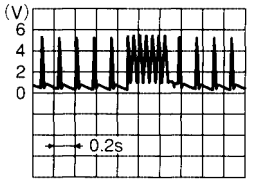
Terminal		Item	Condition	Voltage (V) (Approx.)	
+	-				
15 (L/W)	Ground	Tire pressure warning check connector	—	5V	
18 (P)		Remote keyless entry receiver (Ground)	—	0V	
19 (V/W)		Remote keyless entry receiver (Power supply)	Stand-by	 <p style="text-align: right; font-size: small;">OCC3879D</p>	
			Press any of the electronic switches		 <p style="text-align: right; font-size: small;">OCC3882D</p>
20 (G/W)		Remote keyless entry receiver (Signal)	Stand-by	 <p style="text-align: right; font-size: small;">OCC3881D</p>	
			Press any of the electronic switches	 <p style="text-align: right; font-size: small;">OCC3880D</p>	
38 (W/L)			Ignition switch	Ignition switch ON or START	Battery voltage
39 (L)			Data line (CAN H)	—	—
40 (P)			Data line (CAN L)	—	—
67 (B)			GND	—	0V
70 (W/B)		Battery power supply	—	Battery voltage	

() : Wire color

TROUBLE DIAGNOSES

EES001DD

ID Registration Procedure

ID REGISTRATION WITH TRANSMITTER ACTIVATION TOOL

This procedure must be done after replacement of a low tire pressure warning transmitter or BCM.

CAUTION:

If CONSULT-II is used with no connection of CONSULT-II CONVERTER, malfunction might be detected during self-diagnosis depending on control unit which carry out CAN communication.

1. With the ignition switch OFF, connect CONSULT-II and CONSULT-II CONVERTER to the data link connector, then turn the ignition switch ON.
2. Select "START (NISSAN BASED VHCL)".
3. Touch "BCM" on "SELECT SYSTEM" screen.

NOTE:

If "BCM" is not indicated, go to [GI-38, "CONSULT-II Data Link Connector \(DLC\) Circuit"](#) .

4. Select "AIR PRESSURE MONITOR" on "SELECT WORK ITEM" screen.
5. Select "WORK SUPPORT" on "SELECT DIAG MODE" screen, and select "ID REGIST".
6. With the transmitter activation tool (J-45295) pushed against the front left transmitter position of the tire air valve, press the button for 5 seconds.

Tool number — (J-45295)

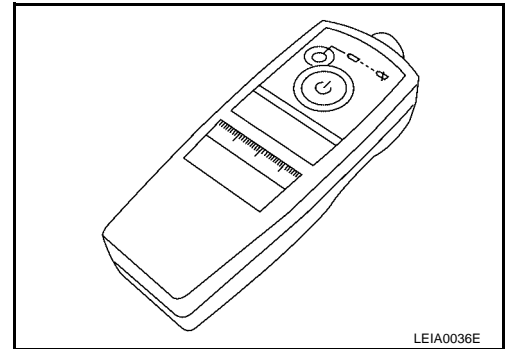

7. Register the IDs in order from FR LH, FR RH, RR RH and RR LH. When ID registration of each wheel has been completed, a buzzer sounds and the warning lamp flashes.

Activation tire position	Buzzer	Hazard warning lamp	CONSULT-II
1 Front LH	Once	2 times flashing	"YET" ↓ "DONE"
2 Front RH	2 times		
3 Rear RH	3 times		
4 Rear LH	4 times		

8. After completing all ID registrations, press "END" to complete the procedure.

NOTE:

Be sure to register the IDs in order from FR LH, FR RH, RR RH, to RR LH, or the self-diagnostic results display will not function properly.

TROUBLE DIAGNOSES

ID REGISTRATION WITHOUT TRANSMITTER ACTIVATION TOOL

This procedure must be done after replacement of a low tire pressure warning transmitter or BCM.

1. With the ignition switch OFF, connect CONSULT-II and CONSULT-II CONVERTER to the data link connector, then turn the ignition switch ON.
2. Select "START (NISSAN BASED VHCL)".
3. Touch "BCM" on "SELECT SYSTEM" screen.

NOTE:

If "BCM" is not indicated, go to [GI-38, "CONSULT-II Data Link Connector \(DLC\) Circuit"](#) .

4. Select "AIR PRESSURE MONITOR" on "SELECT WORK ITEM" screen.
5. Select "WORK SUPPORT" on "SELECT DIAG MODE" screen, and select "ID REGIST".
6. Adjust the tire pressure to the values shown in the table below for ID registration, and drive the vehicle at 15 km/h (9.4 MPH) or more for a few minutes.

Tire position	Tire pressure kPa (kg/cm ² , psi)
Front – Left	250 (2.5, 36)
Front – Right	230 (2.3, 33)
Rear – Right	210 (2.1, 30)
Rear – Left	190 (1.9, 27)

7. After completing all ID registrations, press "END" to complete the procedure.

Activation tire position	CONSULT-II
Front LH	"YET" ↓ "DONE"
Front RH	
Rear RH	
Rear LH	

8. Inflate all tires to proper pressure.

Tire pressure

17 inch tire : 240 kPa (2.4 kg/cm² , 35 psi)

18 inch tire : 240 kPa (2.4 kg/cm² , 35 psi)

TROUBLE DIAGNOSES

Transmitter Wake Up Operation WITH TRANSMITTER ACTIVATION TOOL

EES001DE

1. With the transmitter activation tool (J-45295) pushed against the front left transmitter, press the button for 5 seconds.

Tool number — (J-45295)

- With ignition switch ON, as the warning lamp flashes per the following diagram, the respective transmitter then must be woken up.

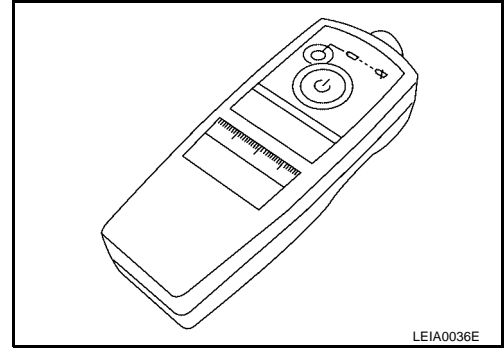

2. When the BCM finishes assigning each tire ID, the BCM flashes the hazard warning lamps and trailer flasher lamps (if equipped) and sends flashing indicator status by CAN according to the following time chart. Please see trailer flasher specification details of trailer flashing lamps since the BCM controls trailer flasher lamps as brake lamps.

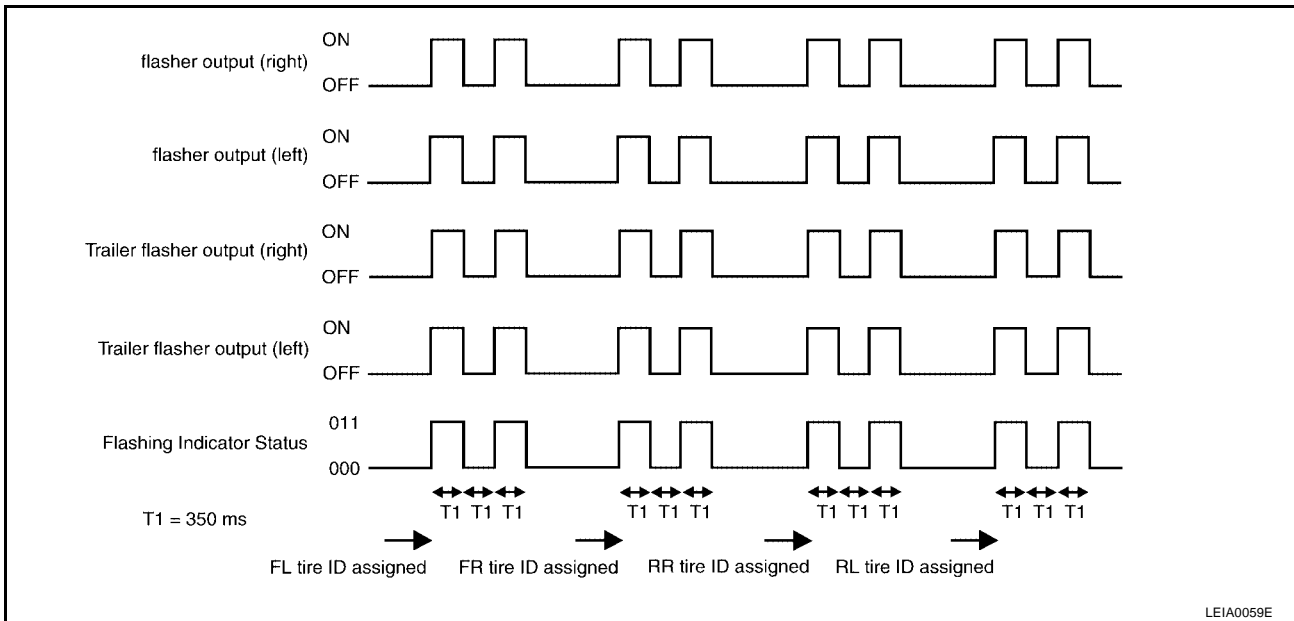

3. After completing wake up of all transmitters, make sure low tire pressure warning lamp goes out.

TROUBLE DIAGNOSES

CONSULT-II Function (BCM)

EES001PY

CONSULT-II can display each diagnostic item using the diagnostic test modes shown following.

BCM diagnostic test item	Diagnostic mode	Description
Inspection by part	WORK SUPPORT	Supports inspections and adjustments. Commands are transmitted to the BCM for setting the status suitable for required operation, input/output signals are received from the BCM and received data is displayed.
	DATA MONITOR	Displays BCM input/output data in real time.
	ACTIVE TEST	Operation of electrical loads can be checked by sending drive signal to them.
	SELF-DIAG RESULTS	Displays BCM self-diagnosis results.
	CAN DIAG SUPPORT MNTR	The result of transmit/receive diagnosis of CAN communication can be read.
	ECU PART NUMBER	BCM part number can be read.
	CONFIGURATION	Performs BCM configuration read/write functions.

TROUBLE DIAGNOSES

EES001DF

Self-Diagnosis DESCRIPTION

During driving, the low tire pressure warning system receives the signal transmitted from the transmitter installed in each wheel, and gives alarms when the tire pressure becomes low. The control unit (BCM) for this system has pressure judgement and trouble diagnosis functions.

FUNCTION

When the low tire pressure warning system detects low inflation pressure or another unusual symptom, the warning lamp in the combination meter comes on. To start the self-diagnostic results mode, ground the tire pressure warning check terminal. The malfunction location is indicated by the warning lamp flashing and the buzzer sounds.

CONSULT-II Application to Low Tire Pressure Warning System

ITEM	SELF-DIAGNOSTIC RESULTS	DATA MONITOR
Front - Left transmitter	×	×
Front - Right transmitter	×	×
Rear - Left transmitter	×	×
Rear - Right transmitter	×	×
Warning lamp	—	×
Vehicle speed	×	×
Buzzer (in combination meter)	—	×
CAN Communication	×	—

× : Applicable

— : Not applicable

Self-Diagnostic Results Mode

Diagnostic item	Diagnostic item is detected when ...
FLAT - TIRE - FL FLAT - TIRE - FR FLAT - TIRE - RR FLAT - TIRE - RL	Front-left tire pressure drops to 193 kPa (2.0 kg/cm ² , 28 psi) or less Front-right tire pressure drops to 193 kPa (2.0 kg/cm ² , 28 psi) or less Rear-right tire pressure drops to 193 kPa (2.0 kg/cm ² , 28 psi) or less Rear-left tire pressure drops to 193 kPa (2.0 kg/cm ² , 28 psi) or less
[NO-DATA] - FL [NO-DATA] - FR [NO-DATA] - RR [NO-DATA] - RL	Data from front-left transmitter cannot be received. Data from front-right transmitter cannot be received. Data from rear-right transmitter cannot be received. Data from rear-left transmitter cannot be received.
[CHECKSUM- ERR] - FL [CHECKSUM- ERR] - FR [CHECKSUM- ERR] - RR [CHECKSUM- ERR] - RL	Checksum data from front-left transmitter is malfunctioning. Checksum data from front-right transmitter is malfunctioning. Checksum data from rear-right transmitter is malfunctioning. Checksum data from rear-left transmitter is malfunctioning.
[PRESSDATA- ERR] - FL [PRESSDATA- ERR] - FR [PRESSDATA- ERR] - RR [PRESSDATA- ERR] - RL	Air pressure data from front-left transmitter is malfunctioning. Air pressure data from front-right transmitter is malfunctioning. Air pressure data from rear-right transmitter is malfunctioning. Air pressure data from rear-left transmitter is malfunctioning.
[CODE- ERR] - FL [CODE- ERR] - FR [CODE- ERR] - RR [CODE- ERR] - RL	Function code data from front-left transmitter is malfunctioning. Function code data from front-right transmitter is malfunctioning. Function code data from rear-right transmitter is malfunctioning. Function code data from rear-left transmitter is malfunctioning.
[BATT - VOLT - LOW] - FL [BATT - VOLT - LOW] - FR [BATT - VOLT - LOW] - RR [BATT - VOLT - LOW] - RL	Battery voltage of front-left transmitter drops. Battery voltage of front-right transmitter drops. Battery voltage of rear-right transmitter drops. Battery voltage of rear-left transmitter drops.
VHCL_SPEED_SIG_ERR	Vehicle speed signal is in error.

NOTE:

Before performing the self-diagnosis, be sure to register the ID or the actual malfunction location may be different from that displayed on CONSULT-II.

TROUBLE DIAGNOSES

Data Monitor Mode

MONITOR	CONDITION	SPECIFICATION
VHCL SPEED	Drive vehicle.	Vehicle speed (km/h or MPH)
AIR PRESS FL AIR PRESS FR AIR PRESS RR AIR PRESS RL	<ul style="list-style-type: none"> ● Drive vehicle for a few minutes. <li style="text-align: center;">or ● Ignition switch ON and activation tool is transmitting activation signals. 	Tire pressure (kPa or psi)
ID REGST FL1 ID REGST FR1 ID REGST RR1 ID REGST RL1	Ignition switch ON	Registration ID: DONE No registration ID: YET
WARNING LAMP		Low tire pressure warning lamp on: ON Low tire pressure warning lamp off: OFF
BUZZER		Buzzer in combination meter on: ON Buzzer in combination meter off : OFF

NOTE:

Before performing the self-diagnosis, be sure to register the ID, or the actual malfunction location may be different from that displayed on CONSULT-II.

TROUBLE DIAGNOSES

How to Perform Trouble Diagnosis for Quick and Accurate Repair INTRODUCTION

EES001DG

- Before troubleshooting, verify customer complaints.
- If a vehicle malfunction is difficult to reproduce, harnesses, harness connectors or terminals may be malfunctioning. Hold and shake these parts to make sure they are securely connected.
- When using a circuit tester to measure voltage or resistance of each circuit, be careful not to damage or deform connector terminals.

WORK FLOW

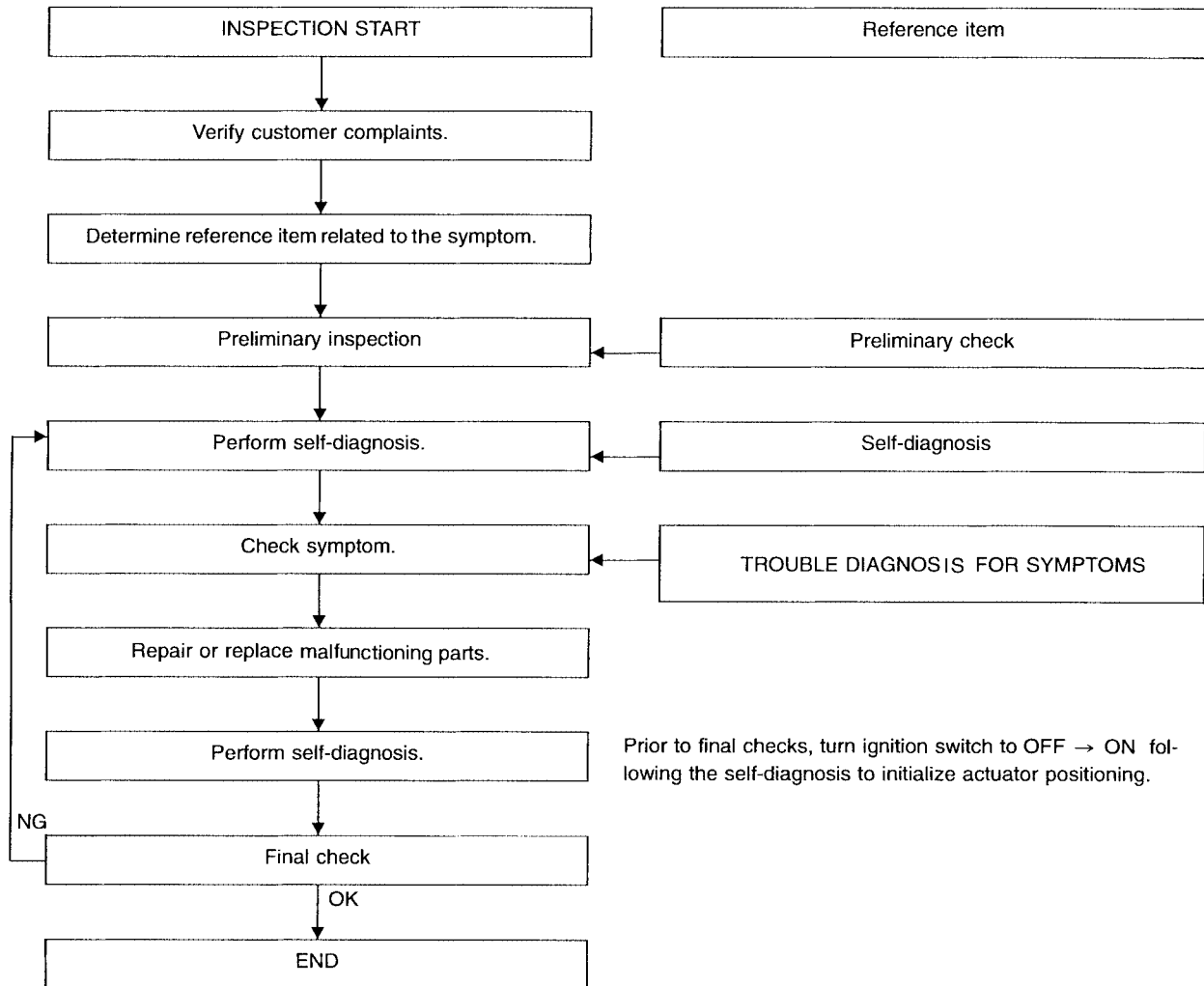

Preliminary check : [WT-20](#)

Self-diagnosis : [WT-17](#)

Trouble diagnosis for symptoms : [WT-26](#)

SEIA0100E

TROUBLE DIAGNOSES

EES001DH

Preliminary Check

BASIC INSPECTION

1. CHECK BCM CONFIGURATION

Confirm BCM configuration for "DISPLAY STYLE" is set to:

- "MODE1" for vehicles without Navigation display screen.
- "MODE2" for vehicles with Navigation display screen.

Refer to [BCS-13, "READ CONFIGURATION PROCEDURE"](#) .

OK or NG

OK >> GO TO 2.

NG >> Change BCM configuration for "DISPLAY STYLE" to "MODE1" or "MODE2". Refer to [BCS-16, "WRITE CONFIGURATION PROCEDURE"](#) .

2. CHECK ALL TIRE PRESSURES

Check all tire pressures.

Tire pressure

17 inch tire : 240 kPa (2.3 kg/cm² , 35 psi)

18 inch tire : 240 kPa (2.4 kg/cm² , 35 psi)

OK or NG

OK >> GO TO 3.

NG >> Adjust tire pressure to specified value.

3. CHECK LOW TIRE PRESSURE WARNING LAMP ACTIVATION

1. Check low tire pressure warning lamp activation.
2. Does low tire pressure warning lamp activate for 1 second when ignition switch is turned "ON"?

Does warning lamp activate?

YES >> GO TO 4.

NO >> Check fuse and combination meter.

4. CHECK CONNECTOR

1. Disconnect BCM harness connector.
2. Check terminals for damage or loose connection.
3. Reconnect harness connector.

OK or NG

OK >> GO TO 5.

NG >> Repair or replace damaged parts.

5. CHECK TRANSMITTER ACTIVATION TOOL

Check transmitter activation tool battery.

OK or NG

OK >> Carry out self-diagnosis.

NG >> Replace transmitter activation tool battery.

TROUBLE DIAGNOSES

Malfunction Code/Symptom Chart

EES001DI

A
B
C
D
WT
F
G
H
I
J
K
L
M

Code/Symptom	Malfunction part	Reference page
15 16 17 18	Front-left tire pressure drops to 193 kPa (2.0 kg/cm ² , 28 psi) or less Front-right tire pressure drops to 193 kPa (2.0 kg/cm ² , 28 psi) or less Rear-right tire pressure drops to 193 kPa (2.0 kg/cm ² , 28 psi) or less Rear-left tire pressure drops to 193 kPa (2.0 kg/cm ² , 28 psi) or less	—
21 22 23 24	Transmitter no data (front - left) Transmitter no data (front - right) Transmitter no data (rear - right) Transmitter no data (rear - left)	WT-23. "Inspection 1: Transmitter or Control Unit (BCM)"
31 32 33 34	Transmitter checksum error (front - left) Transmitter checksum error (front - right) Transmitter checksum error (rear - right) Transmitter checksum error (rear - left)	WT-23. "Inspection 2: Transmitter - 1"
35 36 37 38	Transmitter pressure data error (front - left) Transmitter pressure data error (front - right) Transmitter pressure data error (rear - right) Transmitter pressure data error (rear - left)	WT-24. "Inspection 3: Transmitter - 2"
41 42 43 44	Transmitter function code error (front - left) Transmitter function code error (front - right) Transmitter function code error (rear - right) Transmitter function code error (rear - left)	WT-23. "Inspection 2: Transmitter - 1"
45 46 47 48	Transmitter battery voltage low (front - left) Transmitter battery voltage low (front - right) Transmitter battery voltage low (rear - right) Transmitter battery voltage low (rear - left)	WT-23. "Inspection 2: Transmitter - 1"
52	Vehicle speed signal	WT-25. "Inspection 4: Vehicle Speed Signal"
Low tire pressure warning lamp does not come on when ignition switch is turned on.	Fuse or combination meter BCM connector or circuit BCM	WT-26. "Inspection 1: Warning Lamp Does Not Come On When Ignition Switch Is Turned On"
Low tire pressure warning lamp stays on when ignition switch is turned on.	Combination meter BCM connector or circuit BCM	WT-26. "Inspection 2: Warning Lamp Stays On When Ignition Switch Is Turned On"
Low tire pressure warning lamp flashes when ignition switch is turned on.	BCM harness connector or circuit BCM Transmitter's mode off ID registration not yet	WT-28. "Inspection 3: Warning Lamp Flashes When Ignition Switch Is Turned On"WT-28

TROUBLE DIAGNOSES

Code/Symptom	Malfunction part	Reference page
Hazard warning lamp flashes when ignition switch is turned on.	BCM harness connector or circuit BCM	WT-28. "Inspection 3: Warning Lamp Flashes When Ignition Switch Is Turned On"
"TIRE PRESSURE" information in display does not exist.	Fuse Display unit BCM	WT-30. "Inspection 5: "TIRE PRESSURE" Information In Display Unit Does Not Exist"
ID registration cannot be completed.	Transmitter Remote keyless entry receiver harness connector or circuit Remote keyless entry receiver BCM harness connector or circuit BCM	WT-30. "Inspection 6: ID Registration Cannot Be Completed"

TROUBLE DIAGNOSIS FOR SELF-DIAGNOSTIC ITEMS

TROUBLE DIAGNOSIS FOR SELF-DIAGNOSTIC ITEMS

PF0:0000

Inspection 1: Transmitter or Control Unit (BCM) MALFUNCTION CODE NO. 21, 22, 23 OR 24

EES001DJ

1. CHECK CONTROL UNIT

Drive for several minutes. Check all tire pressures with CONSULT-II "DATA MONITOR ITEM".

Are all tire pressures displayed as 0 kPa?

- YES >> GO TO 2.
- NO >> GO TO 3.

2. CHECK REMOTE KEYLESS ENTRY RECEIVER CONNECTOR

Check remote keyless entry receiver connector for damage or loose connections.

OK or NG

- OK >> Replace BCM, then GO TO 3. Refer to [BCS-19, "Removal and Installation of BCM"](#) .
- NG >> Repair or replace remote keyless entry receiver connector.

3. ID REGISTRATION

Carry out ID registration of all transmitters.

Is there a tire that cannot register ID?

- YES >> Replace transmitter of the tire, then GO TO 5. Refer to [WT-31, "Transmitter \(Pressure Sensor\)"](#) .
- NO >> GO TO 4.

4. VEHICLE DRIVING

1. Drive at a speed of 40 km/h (25 MPH) or more for several minutes without stopping.
2. Check all tire pressures with CONSULT-II "DATA MONITOR ITEM" within 15 minutes after vehicle speed becomes 17 km/h (11 MPH).

Does "DATA MONITOR ITEM" display tire pressure as normal without any warning lamp?

- YES >> Inspection End.
- NO >> GO TO 5.

5. ID REGISTRATION AND VEHICLE DRIVING

1. Carry out ID registration of all transmitters.
2. Drive at a speed of 40 km/h (25 MPH) or more for 3 minutes, and then drive the vehicle at any speed for 10 minutes. Then check all tire pressures with CONSULT-II "DATA MONITOR ITEM" within 5 minutes.

Does "DATA MONITOR ITEM" display tire pressure as normal without any warning lamp?

- YES >> Inspection End.
- NO >> GO TO the inspection applicable to DTC.

Inspection 2: Transmitter - 1

MALFUNCTION CODE NO. 31, 32, 33, 34, 41, 42, 43, 44, 45, 46, 47 OR 48

EES001DK

1. ID REGISTRATION (CORRECTION OF TRANSMITTER LOCATION)

1. Carry out ID registration of all transmitters.
2. Drive at a speed of 40 km/h (25 MPH) or more for 3 minutes, and then drive the vehicle at any speed for 10 minutes.

>> GO TO 2.

TROUBLE DIAGNOSIS FOR SELF-DIAGNOSTIC ITEMS

2. REPLACE TRANSMITTER

1. Check low tire pressure warning lamp again for flashing, replace malfunctioning transmitter.
2. Carry out ID registration of all transmitters.

Can ID registration of all transmitters be completed?

YES >> GO TO 3.

NO >> GO TO Inspection 1. Refer to [WT-23, "Inspection 1: Transmitter or Control Unit \(BCM\)"](#).

3. VEHICLE DRIVING

Drive at a speed of 40 km/h (25 MPH) or more for 3 minutes, and then drive the vehicle at any speed for 10 minutes. Then check all tire pressures with CONSULT-II "DATA MONITOR ITEM" within 5 minutes.

Does "DATA MONITOR ITEM" display tire pressure as normal without any warning lamp?

YES >> Inspection End.

NO >> Replace malfunctioning transmitter, and perform "Step 3" again. Refer to [WT-31, "Transmitter \(Pressure Sensor\)"](#).

Inspection 3: Transmitter - 2 MALFUNCTION CODE NO. 35, 36, 37 OR 38

EES001DL

1. CHECK ALL TIRE PRESSURES

Check all tire pressures.

Tire pressure

17 inch tire : 240 kPa (2.4 kg/m² , 35 psi)

18 inch tire : 240 kPa (2.4 kg/m² , 35 psi)

Are there any tires with pressure of "64 psi" or more?

YES >> Adjust tire pressure to specified value.

NO >> GO TO 2.

2. VEHICLE DRIVING

1. Carry out ID registration of all transmitters.
2. Drive at a speed of 40 km/h (25 MPH) or more for several minutes without stopping. Check all tire pressures with CONSULT-II "DATA MONITOR ITEM" within 15 minutes after vehicle speed becomes 17 km/h (11 MPH).

>> Replace transmitter with new one if "DATA MONITOR ITEM" displays 64 psi or more. Refer to [WT-31, "Transmitter \(Pressure Sensor\)"](#). Then GO TO 3.

3. ID REGISTRATION AND VEHICLE DRIVING

1. Carry out ID registration of all transmitters.
2. Drive at a speed of 40 km/h (25 MPH) or more for 3 minutes, and then drive the vehicle at any speed for 10 minutes. Then check all tire pressures with CONSULT-II "DATA MONITOR ITEM" within 5 minutes.

Does "DATA MONITOR ITEM" display tire pressure as normal without any warning lamp?

YES >> Inspection End.

NO >> GO TO the inspection applicable to DTC.

TROUBLE DIAGNOSIS FOR SELF-DIAGNOSTIC ITEMS

Inspection 4: Vehicle Speed Signal MALFUNCTION CODE NO. 52

EES001DM

1. SELF-DIAGNOSTIC RESULT CHECK

1. With the ignition switch OFF, connect CONSULT-II and CONSULT-II CONVERTER to the data link connector, then turn the ignition switch ON. A
2. Select "START (NISSAN BASED VHCL)". B
3. Select "BCM" on "SELECT SYSTEM" screen. C

NOTE:

If the BCM is not indicated, refer to [GI-38, "CONSULT-II Data Link Connector \(DLC\) Circuit"](#)

4. Select "BCM C/U" on "SELECT WORK ITEM" screen, and select "SELF-DIAG RESULTS". D
5. Check display contents in self-diagnostic results.

Is "CAN COMM CIRCUIT" displayed in the self-diagnosis display items?

- YES >> Malfunction in CAN communication system. GO TO [LAN-7, "CAN COMMUNICATION"](#)
- NO >> GO TO 2. WT

2. CHECK BCM

Perform BCM diagnosis. Refer to [BCS-11, "CONSULT-II INSPECTION PROCEDURE"](#).

Inspection results OK? F

- OK >> Perform Vehicle Speed Sensor Inspection. Refer to [AT-112, "Diagnostic Procedure"](#).
- NG >> Replace BCM. Refer to [BCS-19, "Removal and Installation of BCM"](#). G

H

I

J

K

L

M

TROUBLE DIAGNOSIS FOR SYMPTOMS

TROUBLE DIAGNOSIS FOR SYMPTOMS

PFP:00007

Inspection 1: Warning Lamp Does Not Come On When Ignition Switch Is Turned On

EES001DN

DIAGNOSTIC PROCEDURE

1. SELF-DIAGNOSTIC RESULT CHECK

1. With the ignition switch OFF, connect CONSULT-II and CONSULT-II CONVERTER to the data link connector, then turn the ignition switch ON.
2. Select "START (NISSAN BASED VHCL)".
3. Select "BCM" on "SELECT SYSTEM" screen.

NOTE:

If the BCM is not indicated, refer to [LAN-7, "CAN COMMUNICATION"](#) .

4. Select "BCM C/U" on "SELECT WORK ITEM" screen, and select "SELF-DIAG RESULTS".
5. Check display contents in self-diagnostic results.

Is "CAN COMM CIRCUIT" displayed in the self-diagnosis display items?

- YES >> Malfunction in CAN communication system. GO TO [LAN-7, "CAN COMMUNICATION"](#)
NO >> GO TO 2.

2. CHECK COMBINATION METER

Check combination meter operation.

Inspection results OK?

- OK >> GO TO 3.
NG >> Check combination meter. Refer to [DI-8, "Combination Meter"](#) .

3. CHECK LOW TIRE PRESSURE WARNING LAMP

Disconnect BCM harness connectors.

Does the low tire pressure warning lamp activate?

- YES >> Replace BCM. Refer to [BCS-19, "Removal and Installation of BCM"](#) .
NO >> Check combination meter and repair or replace. Refer to [DI-25, "Removal and Installation of Combination Meter"](#) .

Inspection 2: Warning Lamp Stays On When Ignition Switch Is Turned On

EES001DO

DIAGNOSTIC PROCEDURE

1. CHECK CONNECTOR

1. Disconnect BCM harness connectors.
2. Check terminals for damage or loose connections.

Inspection results OK?

- OK >> GO TO 2.
NG >> Repair or replace damaged parts.

TROUBLE DIAGNOSIS FOR SYMPTOMS

2. CHECK POWER SUPPLY CIRCUIT (BAT)

Check voltage between BCM harness connector M20 terminal 70 (W/B) and ground.

Terminals			Voltage (Approx.)
(+)		(-)	
Connector	Terminal (Wire color)	Ground	12 V
M20	70 (W/B)		

OK or NG

- OK >> GO TO 3.
- NG >> Check BCM power supply circuit for open or short.

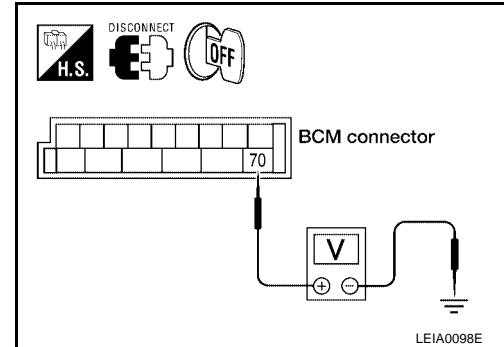

3. CHECK POWER SUPPLY CIRCUIT (IGN)

1. Turn ignition switch ON.
2. Check voltage between BCM harness connector M18 terminal 38 (W/L) and ground.

Terminals			Voltage (Approx.)
(+)		(-)	
Connector	Terminal (Wire color)	Ground	12 V
M18	38 (W/L)		

OK or NG

- OK >> GO TO 4.
- NG >> Check BCM power supply circuit for open or short.

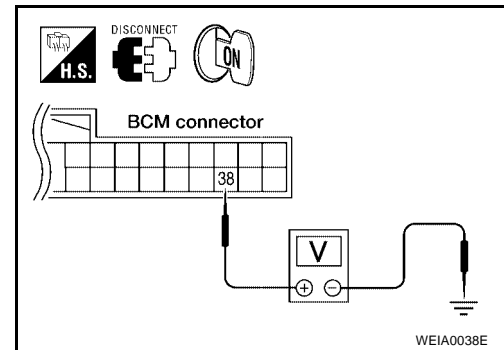

4. CHECK GROUND CIRCUIT

Check continuity between BCM harness connector M20 terminal 67 (B) and ground.

Terminals		Continuity	
(+)		(-)	
Connector	Terminal (Wire color)	Ground	Yes
M20	67 (B)		

OK or NG

- OK >> Replace BCM. Refer to [BCS-19, "Removal and Installation of BCM"](#).
- NG >> Repair or replace BCM ground circuit.

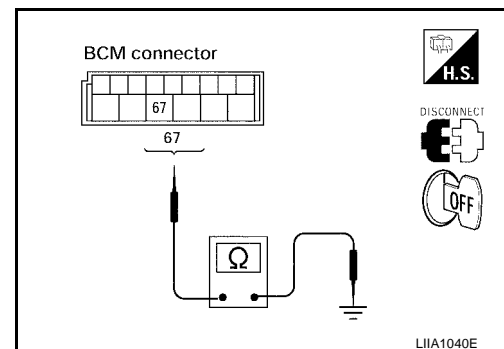

TROUBLE DIAGNOSIS FOR SYMPTOMS

Inspection 3: Warning Lamp Flashes When Ignition Switch Is Turned On

EES001DP

NOTE:

If warning lamp flashes as shown, the system is normal.

Flash Mode A

- This mode shows transmitter status is OFF-mode. Carry out transmitter wake up operation. Refer to [WT-15, "Transmitter Wake Up Operation"](#).

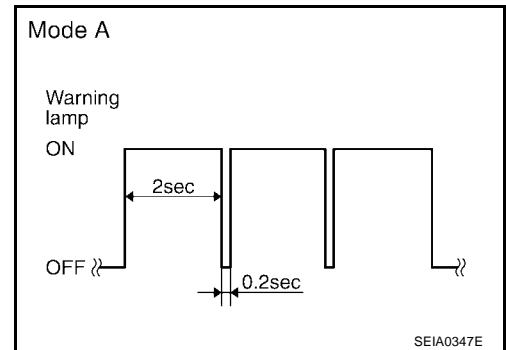

DIAGNOSTIC PROCEDURE

1. CHECK CONNECTOR

- Disconnect BCM harness connectors M18 and M20.
- Check terminals for damage or loose connections.

Inspection results OK?

- OK >> GO TO 2.
NG >> Repair or replace damaged parts.

2. CHECK TIRE PRESSURE WARNING CHECK CONNECTOR CIRCUIT

Check continuity between BCM harness connector M18 terminal 15 (L/W) and check connector M123 terminal 1 (L/W).

Continuity should exist

OK or NG

- OK >> Replace BCM. Refer to [BCS-19, "Removal and Installation of BCM"](#).
- NG >> Repair or replace harness connector.

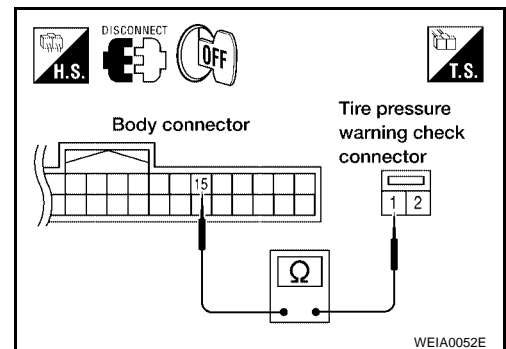

TROUBLE DIAGNOSIS FOR SYMPTOMS

Inspection 4: Hazard Warning Lamp Flashes When Ignition Switch Is Turned On

EES001DQ

DIAGNOSTIC PROCEDURE

1. CHECK GROUND CIRCUIT

1. Disconnect BCM harness connector M20.
2. Check continuity between BCM harness connector M20 terminal 67 (B) and ground.

Terminals		Continuity
(+)	(-)	
Connector	Terminal (Wire color)	Ground
M20	67 (B)	Yes

OK or NG

- OK >> Replace BCM. Refer to [BCS-19, "Removal and Installation of BCM"](#).
- NG >> Repair or replace BCM ground circuit.

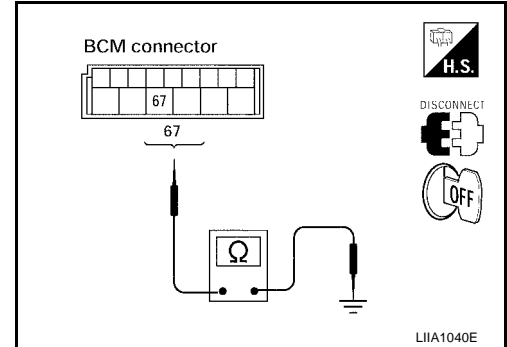

TROUBLE DIAGNOSIS FOR SYMPTOMS

Inspection 5: "TIRE PRESSURE" Information In Display Unit Does Not Exist

EES001DR

DIAGNOSTIC PROCEDURE

1. SELF-DIAGNOSTIC RESULT CHECK

1. With the ignition switch OFF, connect CONSULT-II and CONSULT-II CONVERTER to the data link connector, then turn the ignition switch ON.
2. Select "START (NISSAN BASED VHCL)".
3. Select "BCM" on "SELECT SYSTEM" screen.

NOTE:

If the BCM is not indicated, refer to [LAN-7, "CAN COMMUNICATION"](#) .

4. Select "BCM C/U" on "SELECT WORK ITEM" screen, and select "SELF-DIAG RESULTS".
5. Check display contents in self-diagnostic results.

Is "CAN COMM CIRCUIT" displayed in the self-diagnosis display items?

- YES >> Malfunction in CAN communication system. GO TO [LAN-7, "CAN COMMUNICATION"](#)
NO >> GO TO 2.

2. CHECK DISPLAY UNIT

Perform display unit self-diagnosis. Refer to [AV-118, "Self-Diagnosis Mode \(DCU\)"](#) (without NAVI) or [AV-121, "Self-Diagnosis Mode \(NAVI\)"](#) (with NAVI).

Inspection results OK?

- OK >> Replace BCM. Refer to [BCS-19, "Removal and Installation of BCM"](#) .
NG >> Repair or replace malfunctioning parts.

Inspection 6: ID Registration Cannot Be Completed

EES001DS

DIAGNOSTIC PROCEDURE

1. ID REGISTRATION (ALL)

Carry out ID registration of all transmitters.

Can ID registration of all transmitters be completed?

- YES >> Inspection End.
NO >> Go To [WT-23, "Inspection 1: Transmitter or Control Unit \(BCM\)"](#) .

REMOVAL AND INSTALLATION

REMOVAL AND INSTALLATION

PF0:0000

EES001DT

Transmitter (Pressure Sensor) REMOVAL

1. Deflate tire. Unscrew transmitter retaining nut and allow transmitter to fall into tire.
2. Gently bounce tire so that transmitter falls to bottom of tire. Place wheel and tire assembly on tire changing machine and break both tire beads. Ensure that the transmitter remains at the bottom of the tire while breaking the bead.

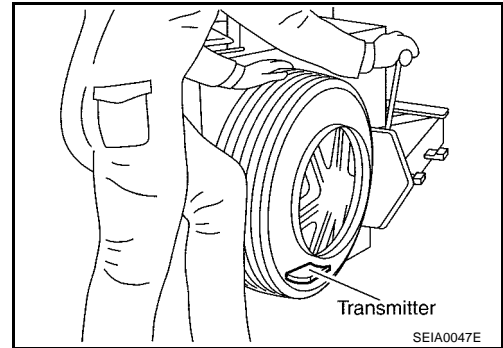

3. Turn tire so that valve hole is at bottom, and gently bounce the tire to ensure transmitter is near valve hole. Carefully lift tire onto turntable and position valve hole (and transmitter) 270 degrees from mounting/dismounting head.
4. Lubricate tire well, and remove top side of tire. Reach inside the tire and remove the transmitter.
5. Remove the second side of the tire as normal.

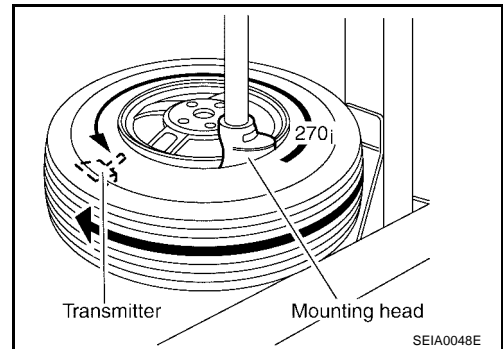

INSTALLATION

1. Place first side of tire onto rim.

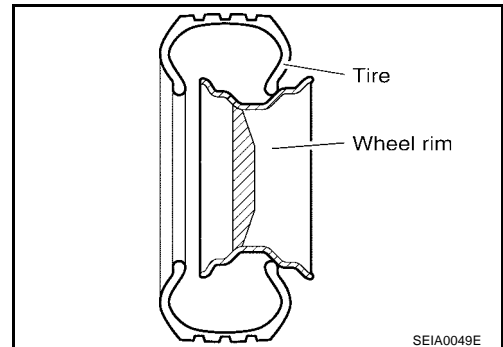

2. Mount transmitter on rim and tighten nut.

**Transmitter nut
tightening torque : 5.5 N·m (0.56 kg·m, 49 in·lb)**

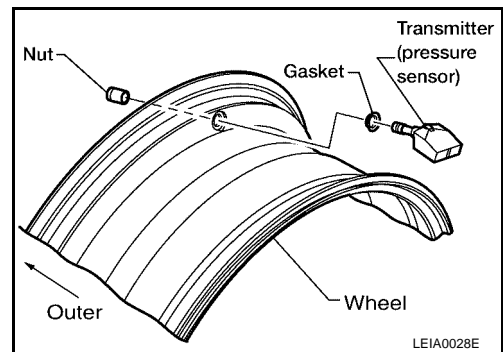

A
B
C
D
WT
F
G
H
I
J
K
L
M

REMOVAL AND INSTALLATION

3. Place wheel on turntable of tire machine. Ensure that transmitter is 270 degrees from mounting/dismounting head.

NOTE:

Do not touch transmitter with mounting head.

4. Lubricate tire well, and install second side of tire as normal. Ensure that tire does not rotate relative to rim.
5. Inflate tire and balance wheel and tire assembly. Refer to [WT-5, "Balancing Wheels"](#).
6. Install Wheel and tire assembly in appropriate wheel position on vehicle.
7. Adjust neutral position of steering angle sensor. Refer to [PS-7, "CHECKING NEUTRAL POSITION ON STEERING WHEEL"](#).

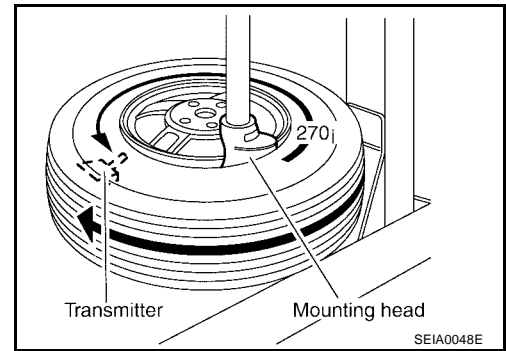

SERVICE DATA AND SPECIFICATIONS (SDS)

SERVICE DATA AND SPECIFICATIONS (SDS)

PF0:00030

Road Wheel

EES001DU

Wheel type		Aluminum	Steel	
			Inside	Outside
Maximum radial runout limit	Lateral mm (in)	0.3 (0.012) or less	1.0 (0.039) or less	0.9 (0.035) or less
	Radial mm (in)	0.3 (0.012) or less	0.8 (0.031) or less	0.4 (0.016) or less
Maximum residual imbalance	Dynamic (at rim flange)	Less than 5 g (0.18 oz) (per side)		
	Static (at rim flange)	Less than 10 g (0.35 oz)		

Tire

EES001DV

Unit: kPa (kg/cm², psi)

Tire size	Air pressure	
	Conventional tire	Spare tire
Full size spare tire	—	240 (2.4, 35)
P245/75R17	240 (2.4, 35)	—
P285/70R17	240 (2.4, 35)	—
P265/70R18	240 (2.4, 35)	—

SERVICE DATA AND SPECIFICATIONS (SDS)
