

SECTION **SRS**

SUPPLEMENTAL RESTRAINT SYSTEM (SRS)

A
B
C
D
E

CONTENTS

<p>PRECAUTIONS 3</p> <p style="padding-left: 20px;">Precautions for Supplemental Restraint System (SRS) "AIR BAG" and "SEAT BELT PRE-TENSIONER" 3</p> <p style="padding-left: 20px;">Precautions for SRS "AIR BAG" and "SEAT BELT PRE-TENSIONER" Service 3</p> <p style="padding-left: 20px;">Occupant Classification System Precaution 3</p> <p style="padding-left: 20px;">Trouble Diagnosis Precaution 3</p> <p>PREPARATION 4</p> <p style="padding-left: 20px;">Special Service Tools 4</p> <p style="padding-left: 20px;">Commercial Service Tools 5</p> <p>SUPPLEMENTAL RESTRAINT SYSTEM (SRS) 6</p> <p style="padding-left: 20px;">SRS Configuration 6</p> <p style="padding-left: 20px;">Front Seat Belt Pre-tensioner with Load Limiter 7</p> <p style="padding-left: 20px;">Front Side Air Bag 7</p> <p style="padding-left: 20px;">Side Curtain Air Bag 7</p> <p style="padding-left: 20px;">Occupant Classification System 7</p> <p style="padding-left: 20px;">Direct-connect SRS Component Connectors 8</p> <p>TROUBLE DIAGNOSIS 9</p> <p style="padding-left: 20px;">Trouble Diagnosis Introduction 9</p> <p style="padding-left: 40px;">DIAGNOSIS FUNCTION 9</p> <p style="padding-left: 40px;">HOW TO PERFORM TROUBLE DIAGNOSES FOR QUICK AND ACCURATE REPAIR 9</p> <p style="padding-left: 40px;">WORK FLOW 10</p> <p style="padding-left: 20px;">SRS Components Parts Location 11</p> <p style="padding-left: 20px;">Schematic 12</p> <p style="padding-left: 20px;">Wiring Diagram — SRS — 13</p> <p style="padding-left: 20px;">CONSULT-II Function (AIR BAG) 19</p> <p style="padding-left: 20px;">CONSULT-II Function 19</p> <p style="padding-left: 40px;">HOW TO CHANGE SELF-DIAGNOSIS MODE WITH CONSULT-II 19</p> <p style="padding-left: 40px;">HOW TO ERASE SELF-DIAGNOSIS RESULTS.. 20</p> <p style="padding-left: 20px;">Self-Diagnosis Function (Without CONSULT-II) 20</p> <p style="padding-left: 40px;">HOW TO CHANGE SELF-DIAGNOSIS MODE.. 20</p> <p style="padding-left: 40px;">HOW TO ERASE SELF-DIAGNOSIS RESULTS.. 21</p> <p style="padding-left: 20px;">SRS Operation Check 21</p> <p style="padding-left: 40px;">DIAGNOSTIC PROCEDURE 1 21</p> <p style="padding-left: 20px;">Trouble Diagnosis With CONSULT-II 23</p> <p style="padding-left: 40px;">DIAGNOSTIC PROCEDURE 2 23</p>	<p style="padding-left: 20px;">DIAGNOSTIC PROCEDURE 3 28</p> <p style="padding-left: 20px;">DIAGNOSTIC PROCEDURE 4 (CONTINUED FROM DIAGNOSTIC PROCEDURE 2) 31</p> <p style="padding-left: 20px;">DIAGNOSTIC PROCEDURE 5 31</p> <p style="padding-left: 20px;">Trouble Diagnosis Without CONSULT-II 37</p> <p style="padding-left: 20px;">DIAGNOSTIC PROCEDURE 6 37</p> <p style="padding-left: 20px;">WARNING LAMP FLASH CODE CHART 38</p> <p style="padding-left: 20px;">Trouble Diagnosis: "AIR BAG" Warning Lamp Does Not Turn Off 42</p> <p style="padding-left: 40px;">DIAGNOSTIC PROCEDURE 6 42</p> <p style="padding-left: 20px;">Trouble Diagnosis: "AIR BAG" Warning Lamp Does Not Turn On 43</p> <p style="padding-left: 40px;">DIAGNOSTIC PROCEDURE 7 43</p> <p>DRIVER AIR BAG MODULE 44</p> <p style="padding-left: 20px;">Removal and Installation 44</p> <p style="padding-left: 40px;">REMOVAL 44</p> <p style="padding-left: 40px;">INSTALLATION 45</p> <p>SPIRAL CABLE 46</p> <p style="padding-left: 20px;">Removal and Installation 46</p> <p style="padding-left: 40px;">REMOVAL 46</p> <p style="padding-left: 40px;">INSTALLATION 47</p> <p>FRONT PASSENGER AIR BAG MODULE 49</p> <p style="padding-left: 20px;">Removal and Installation 49</p> <p style="padding-left: 40px;">REMOVAL 49</p> <p style="padding-left: 40px;">INSTALLATION 49</p> <p style="padding-left: 40px;">WIRING HARNESS MODIFICATION 50</p> <p>FRONT SIDE AIR BAG MODULE 52</p> <p style="padding-left: 20px;">Removal and Installation 52</p> <p style="padding-left: 40px;">REMOVAL 52</p> <p style="padding-left: 40px;">INSTALLATION 52</p> <p>SIDE CURTAIN AIR BAG MODULE 53</p> <p style="padding-left: 20px;">Removal and Installation 53</p> <p style="padding-left: 40px;">REMOVAL 53</p> <p style="padding-left: 40px;">INSTALLATION 53</p> <p>CRASH ZONE SENSOR 55</p> <p style="padding-left: 20px;">Removal and Installation 55</p> <p style="padding-left: 40px;">REMOVAL 55</p> <p style="padding-left: 40px;">INSTALLATION 55</p>
---	---

SRS

F
G
I
J
K
L
M

SIDE AIR BAG (SATELLITE) SENSOR	56	BELT PRE-TENSIONER (OUTSIDE OF VEHICLE)	65
Removal and Installation	56	DEPLOYMENT OF AIR BAG MODULES AND SEAT BELT PRE-TENSIONERS WHILE MOUNTED IN VEHICLE	65
REMOVAL	56	DISPOSING OF AIR BAG MODULE AND SEAT BELT PRE-TENSIONER	66
INSTALLATION	56	COLLISION DIAGNOSIS	67
FRONT SEAT BELT PRE-TENSIONER	57	For Frontal Collision	67
Removal and Installation	57	SRS INSPECTION (FOR FRONTAL COLLISION)	67
DIAGNOSIS SENSOR UNIT	58	For Side Collision	68
Removal and Installation	58	WHEN SRS IS ACTIVATED IN THE SIDE COLLISION	68
REMOVAL	58	WHEN SRS IS NOT ACTIVATED IN THE SIDE COLLISION	68
INSTALLATION	58	SRS INSPECTION (FOR SIDE COLLISION)	68
ECU DISCRIMINATED NO.	58	For Rollover	69
OCCUPANT CLASSIFICATION SYSTEM CONTROL UNIT	59	WHEN SRS IS ACTIVATED IN THE ROLLOVER	69
Removal and Installation	59	WHEN SRS IS NOT ACTIVATED IN THE ROLLOVER	69
DISPOSAL OF AIR BAG MODULE AND SEAT BELT PRE-TENSIONER	60	SRS INSPECTION (FOR ROLLOVER)	70
Caution for Air Bag Module and Seat Belt Pre-tensioner	60		
CHECKING DEPLOYMENT TOOL	60		
DEPLOYMENT PROCEDURES FOR AIR BAG MODULE (OUTSIDE OF VEHICLE)	61		
DEPLOYMENT PROCEDURES FOR SEAT			

PRECAUTIONS

PRECAUTIONS

PF0:00001

Precautions for Supplemental Restraint System (SRS) “AIR BAG” and “SEAT BELT PRE-TENSIONER”

EHS0013S

The Supplemental Restraint System such as “AIR BAG” and “SEAT BELT PRE-TENSIONER”, used along with a front seat belt, helps to reduce the risk or severity of injury to the driver and front passenger for certain types of collision. This system includes seat belt switch inputs and dual stage front air bag modules. The SRS system uses the seat belt switches to determine the front air bag deployment, and may only deploy one front air bag, depending on the severity of a collision and whether the front occupants are belted or unbelted. Information necessary to service the system safely is included in the SRS and SB section of this Service Manual.

WARNING:

- To avoid rendering the SRS inoperative, which could increase the risk of personal injury or death in the event of a collision which would result in air bag inflation, all maintenance must be performed by an authorized NISSAN/INFINITI dealer.
- Improper maintenance, including incorrect removal and installation of the SRS, can lead to personal injury caused by unintentional activation of the system. For removal of Spiral Cable and Air Bag Module, see the SRS section.
- Do not use electrical test equipment on any circuit related to the SRS unless instructed to in this Service Manual. SRS wiring harnesses can be identified by yellow and/or orange harnesses or harness connectors.

Precautions for SRS “AIR BAG” and “SEAT BELT PRE-TENSIONER” Service

EHS0013T

- Do not use electrical test equipment to check SRS circuits unless instructed to in this Service Manual.
- Before servicing the SRS, turn ignition switch OFF, disconnect both battery cables and wait at least 3 minutes.
For approximately 3 minutes after the cables are removed, it is still possible for the air bags and seat belt pre-tensioners to deploy. Therefore, do not work on any SRS connectors or wires until at least 3 minutes have passed.
- The air bag diagnosis sensor unit must always be installed with the arrow mark “⇐” pointing toward the front of the vehicle for proper operation. Also check air bag diagnosis sensor unit for cracks, deformities or rust before installation and replace as required.
- The spiral cable must be aligned with the neutral position since its rotations are limited. Do not attempt to turn steering wheel or column after removal of steering gear.
- Handle air bag module carefully. Always place driver and front passenger air bag modules with the pad side facing upward and seat mounted front side air bag module standing with the stud bolt side facing down.
- Conduct self-diagnosis to check entire SRS for proper function after replacing any components.
- After air bag inflates, the front instrument panel assembly should be replaced if damaged.

SRS

Occupant Classification System Precaution

EHS0013U

Replace occupant classification system control unit and passenger front seat cushion as an assembly.

Trouble Diagnosis Precaution

EHS0013V

When you read wiring diagrams, refer to the following:

- [GI-14, "How to Read Wiring Diagrams"](#) in GI section
- [PG-4, "POWER SUPPLY ROUTING CIRCUIT"](#) in PG section

When you perform trouble diagnosis, refer to the following:

- [GI-11, "HOW TO FOLLOW TEST GROUPS IN TROUBLE DIAGNOSES"](#) in GI section
- [GI-27, "How to Perform Efficient Diagnosis for an Electrical Incident"](#) in GI section

Check for any service bulletins before servicing the vehicle.

PREPARATION

PREPARATION

PF0:0002

Special Service Tools

EHS0013W

The actual shapes of Kent-Moore tools may differ from those of special service tools illustrated here.

Tool number (Kent-Moore No.) Tool name	Description
KV99105300 (J-41246) Air bag module bracket	Anchoring air bag module
— (J-39401-100) Passenger air bag module bracket	Anchoring passenger air bag module
KV99106400 (J-38381) Deployment tool	Disposing of air bag modules and front seat belt pre-tensioners
— (J-38381-80) Deployment tool adapter for front driver air bag module, passenger air bag module, side curtain air bag module and front seat belt pre-tensioner	Connecting between the deployment tool and front driver air bag module, passenger air bag module, side curtain air bag module and front seat belt pre-tensioner
— (J-38381-65) Deployment tool adapter for front passenger air bag module (for service kit level)	Connecting between the deployment tool and front passenger air bag module

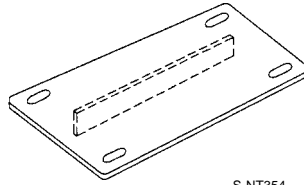

S-NT354

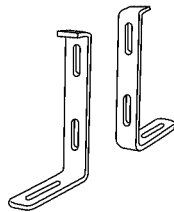

LHIA0045E

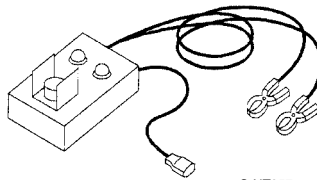

S-NT357

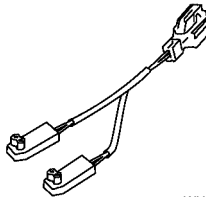

WHIA0089E

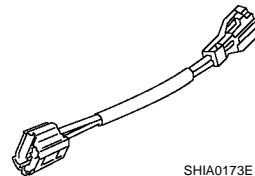

SHIA0173E

PREPARATION

Tool number (Kent-Moore No.) Tool name	Description
KV99109000 (J-44230) Deployment tool adapter for front side air bag module	Connecting between the deployment tool and front side air bag module
— (J-42057-UPD) Air bag key set Part of kit (J-42057)	Removing and installing air bag lock

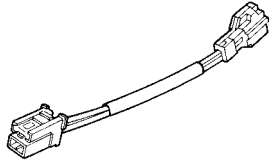

ZZA1190D



LRS210

Commercial Service Tools

EHS0013X

(Kent-Moore No.) Tool name	Description
(J-1859A) Steering wheel puller	Removing steering wheel
(J-42578) Steering wheel puller legs	Removing steering wheel

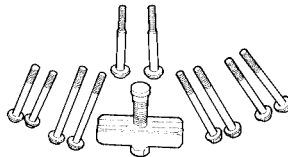

LHIA0043E

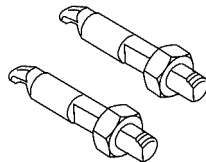

LHIA0044E

A
B
C
D
E
F
G
I
J
K
L
M

SRS

SUPPLEMENTAL RESTRAINT SYSTEM (SRS)

SUPPLEMENTAL RESTRAINT SYSTEM (SRS)

PPF:28556

SRS Configuration

EHS0013Y

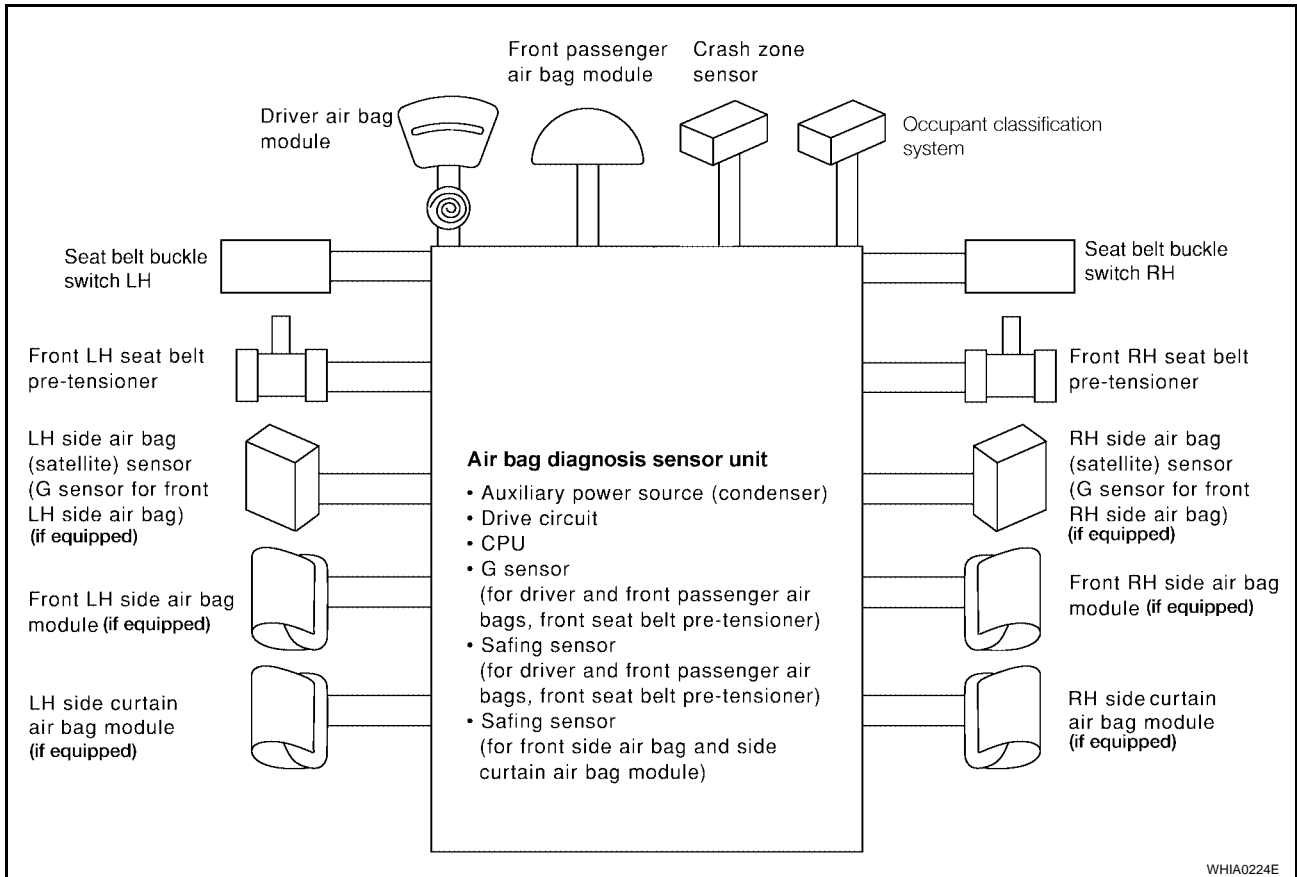

The air bag deploys if the air bag diagnosis sensor unit is activated while the ignition switch is in the ON or START position.

The collision modes for which supplemental restraint systems are activated are different among the SRS systems. For example, the driver air bag module, front passenger air bag module and front seat belt pre-tensioners are activated in a frontal collision but not in a side collision.

SRS configurations for some collision modes are as follows:

SRS configuration	Frontal collision	Left side collision	Right side collision	Rollover
Driver air bag module	×	—	—	—
Front passenger air bag module	×	—	—	—
Front LH seat belt pre-tensioner	×	—	—	×
Front RH seat belt pre-tensioner	×	—	—	×
Front LH side air bag module (if equipped)	—	×	—	—
Front RH side air bag module (if equipped)	—	—	×	—
LH side curtain air bag module (if equipped)	—	×	—	×
RH side curtain air bag module (if equipped)	—	—	×	×

SUPPLEMENTAL RESTRAINT SYSTEM (SRS)

Front Seat Belt Pre-tensioner with Load Limiter

EHS0013Z

The seat belt pre-tensioner system with load limiter is installed for both the driver's seat and the front passenger's seat. It operates simultaneously with the SRS air bag system in the event of a frontal collision with an impact exceeding a specified level.

When the frontal collision with an impact exceeding a specified level occurs, seat belt slack resulting from clothing or other factors is immediately taken up by the pre-tensioner. Vehicle passengers are securely restrained.

When passengers in a vehicle are thrown forward in a collision and the restraining force of the seat belt exceeds a specified level, the load limiter permits the specified extension of the seat belt by the twisting of the ELR shaft, and a relaxation of the chest-area seat belt web tension while maintaining force.

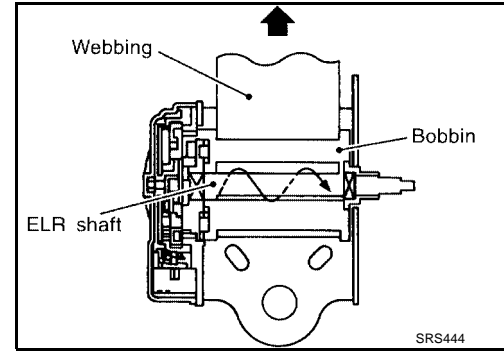

Front Side Air Bag

EHS00140

Front side air bag modules are built into the front seatback assemblies. Vehicles with side air bags are equipped with labels as shown.

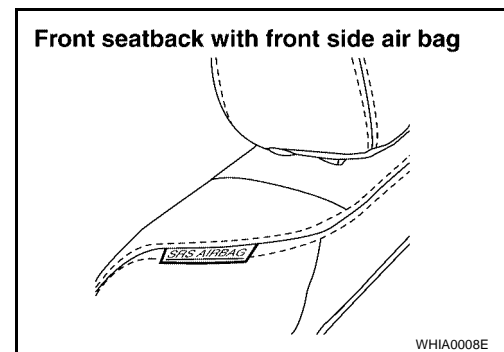

Side Curtain Air Bag

EHS00141

Side curtain air bag modules are located above the vehicle headlining. Vehicles with side curtain air bags are equipped with labels as shown.

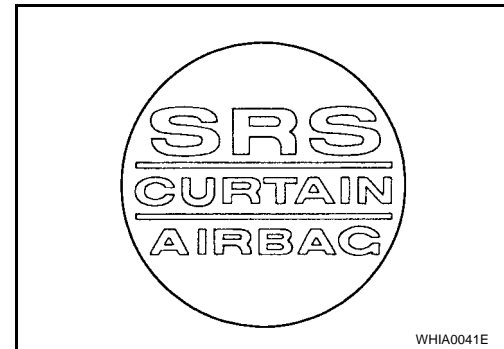

Occupant Classification System

EHS001B5

The occupant classification system identifies different size occupants, out of position occupants, and detects if child seat is present in the front passenger seat. The occupant classification system receives inputs from the occupant classification system sensor (located inside the passenger seat cushion assembly) and belt tension sensor (part of the passenger front seat belt assembly and located at the belt anchor location). Depending on classification of passenger, the occupant classification system sends a signal to the air bag diagnosis sensor unit. The air bag diagnosis sensor unit uses this signal to determine deployment or non deployment of the passenger front air bag in the event of a collision. Depending on the signal received, the air bag diagnosis sensor

A
B
C
D
E
F
G
SRS
I
J
K
L
M

SUPPLEMENTAL RESTRAINT SYSTEM (SRS)

unit can disable the passenger front air bag completely. If this occurs the air bag diagnosis sensor unit will turn on the PASS AIR BAG OFF indicator.

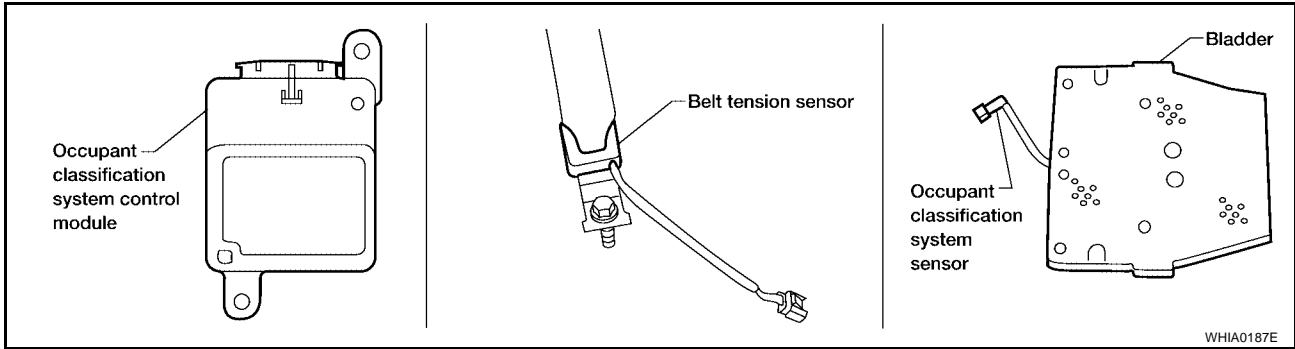

Direct-connect SRS Component Connectors

EHS00143

The following SRS components use direct-connect style harness connectors.

- Driver front air bag module
- Passenger front air bag module
- LH side curtain air bag module
- RH side curtain air bag module
- Front LH seat belt pre-tensioner
- Front RH seat belt pre-tensioner

Always pull up to release black locking tab prior to removing connector from SRS component. Always push down to lock black locking tab after installing connector to SRS component. When locked, the black locking tab is level with the connector housing.

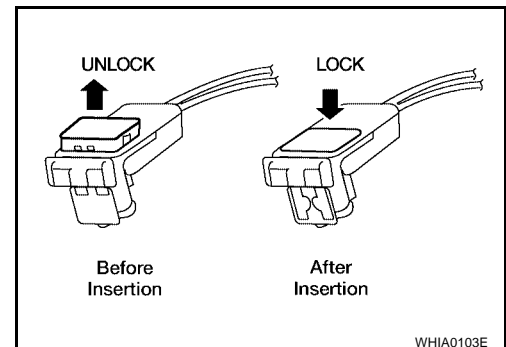

TROUBLE DIAGNOSIS

Trouble Diagnosis Introduction

EHS00144

CAUTION:

- Do not use electrical test equipment on any circuit related to the SRS unless instructed to do so in this Service Manual. SRS wiring harnesses can be identified by yellow and/or orange harness connectors.
- Do not attempt to repair, splice or modify SRS wiring harnesses. If a harness is damaged, replace it with a new one.
- Keep ground connections clean.

DIAGNOSIS FUNCTION

The SRS self-diagnosis results can be read by using "AIR BAG" warning lamp and/or CONSULT-II. The User mode is exclusively prepared for the customer (driver). This mode warns the driver of a system malfunction through the operation of the "AIR BAG" warning lamp. The Diagnosis mode allows the technician to locate and inspect the malfunctioning part. The mode applications for the "AIR BAG" warning lamp and CONSULT-II are as follows:

	User mode	Diagnosis mode	Display type
"AIR BAG" warning lamp	X	X	ON-OFF operation
CONSULT-II	—	X	Monitoring

HOW TO PERFORM TROUBLE DIAGNOSES FOR QUICK AND ACCURATE REPAIR

A good understanding of the malfunction conditions can make troubleshooting faster and more accurate. In general, each customer feels differently about a malfunction. It is important to fully understand the symptoms or conditions for a customer complaint.

Information From Customer

- WHAT - Vehicle model
- WHEN - Date, Frequencies
- WHERE - Road conditions
- HOW - Operating conditions, Symptoms

Preliminary Check

- Check that the following parts are in good order.
- Battery (Refer to [SC-4, "How to Handle Battery"](#) .)
 - Fuse (Refer to [SRS-13, "Wiring Diagram — SRS —"](#) .)
 - System component-to-harness connections

A
B
C
D
E
F
G
I
J
K
L
M



TROUBLE DIAGNOSIS

WORK FLOW

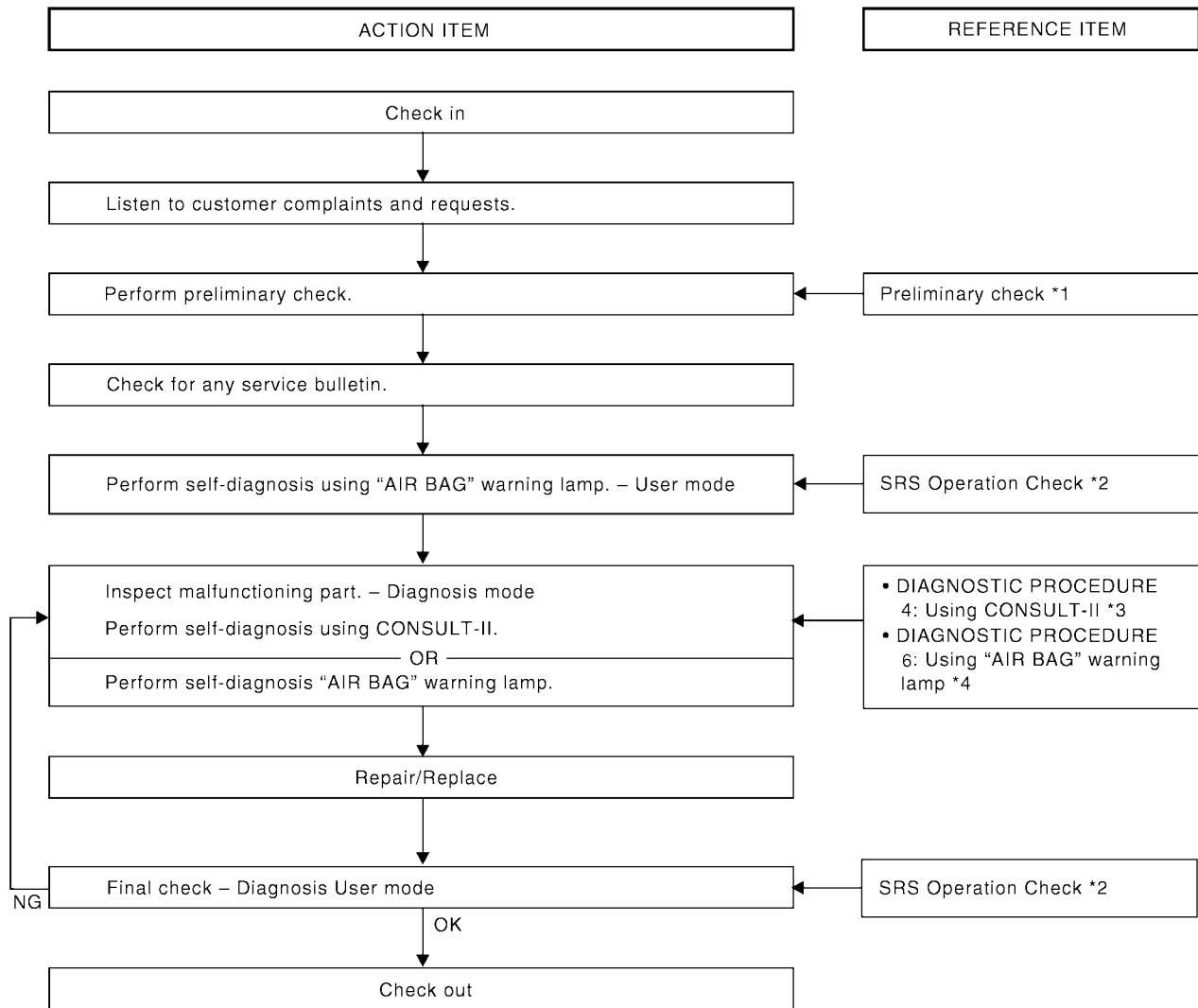

WHIA0098E

*1: [SRS-9](#)

*2: [SRS-21](#)

*3: [SRS-31](#)

*4: [SRS-37](#)

TROUBLE DIAGNOSIS

SRS Components Parts Location

EHS00145

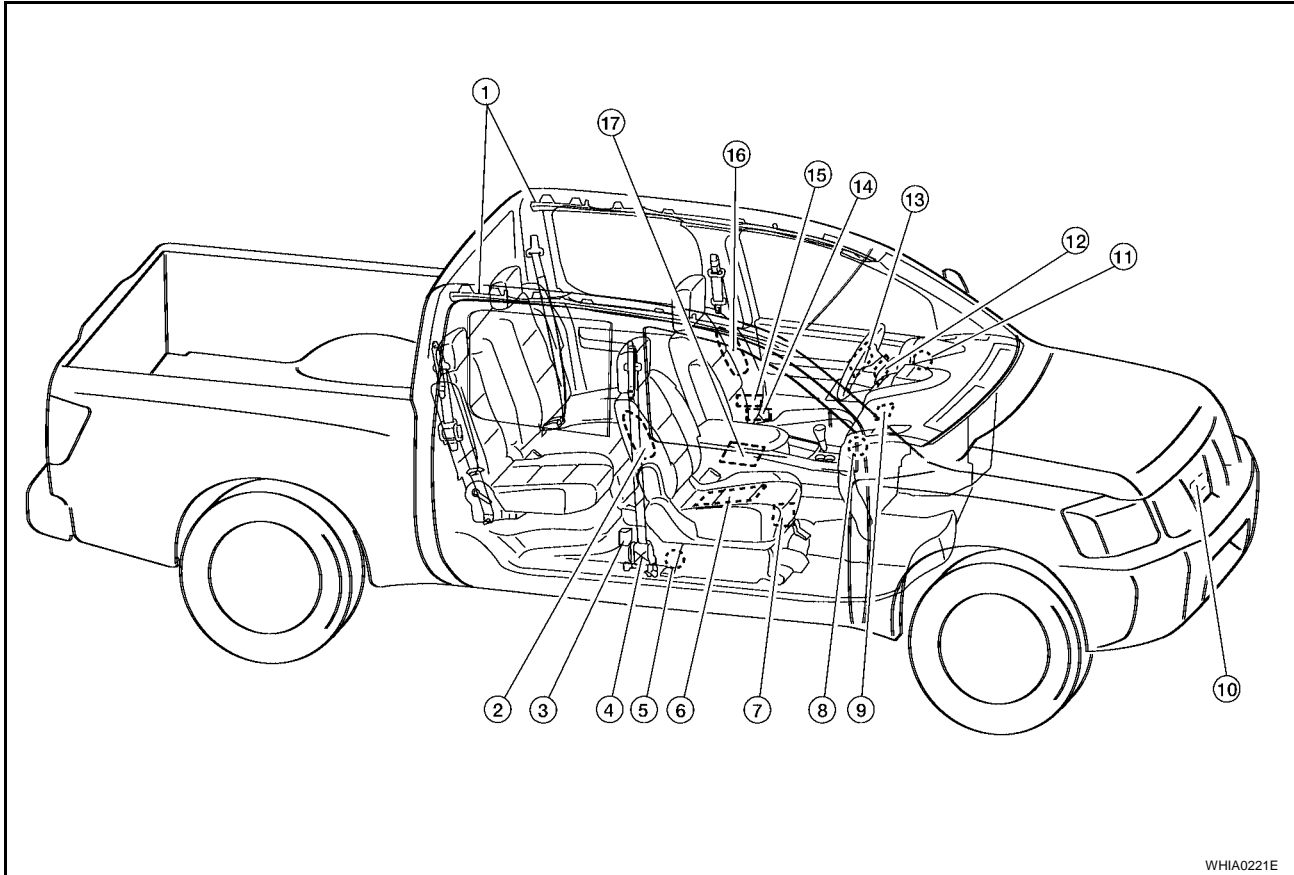

WHIA0221E

- | | | |
|--|---|--|
| 1. Side curtain air bag modules (If equipped) | 2. Front RH side air bag module (If equipped) | 3. RH side air bag (satellite) sensor (If equipped) |
| 4. Front RH seatbelt pre-tensioner | 5. Belt tension sensor | 6. Occupant classification system sensor |
| 7. Occupant classification system control unit | 8. Front passenger air bag off indicator | 9. Front passenger air bag module |
| 10. Crash zone sensor | 11. Air bag warning lamp | 12. Spiral cable |
| 13. Driver air bag module | 14. Front LH seatbelt pre-tensioner | 15. LH side air bag (satellite) sensor (If equipped) |
| 16. Front LH side air bag module (If equipped) | 17. Air bag diagnosis sensor unit | |

A
B
C
D
E
F
G
SRS
I
J
K
L
M

TROUBLE DIAGNOSIS

Schematic

EHS00146

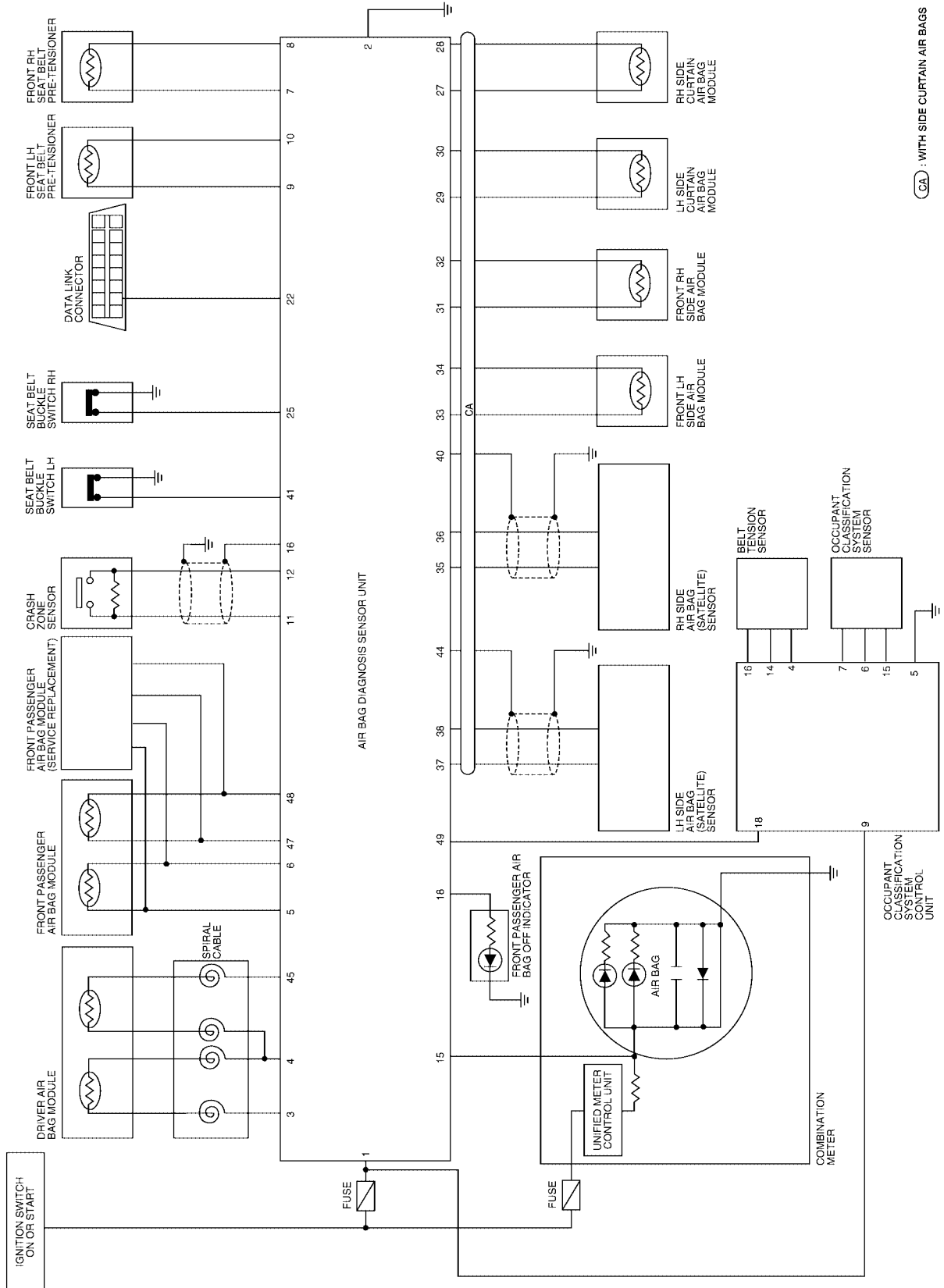

WHWA0126E

TROUBLE DIAGNOSIS

Wiring Diagram — SRS —

EHS00147

SRS-SRS-01

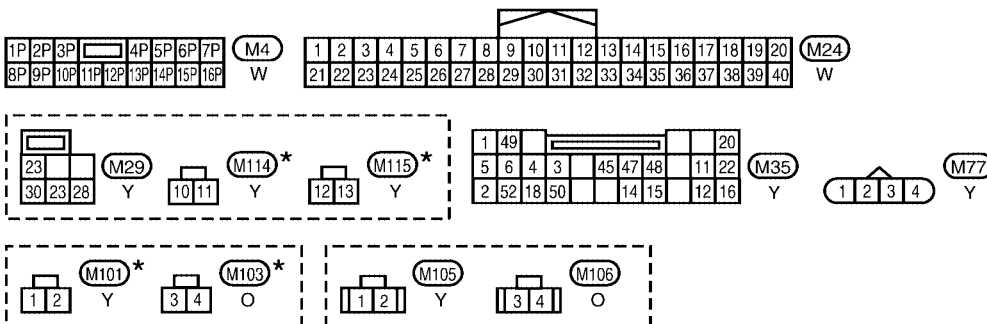
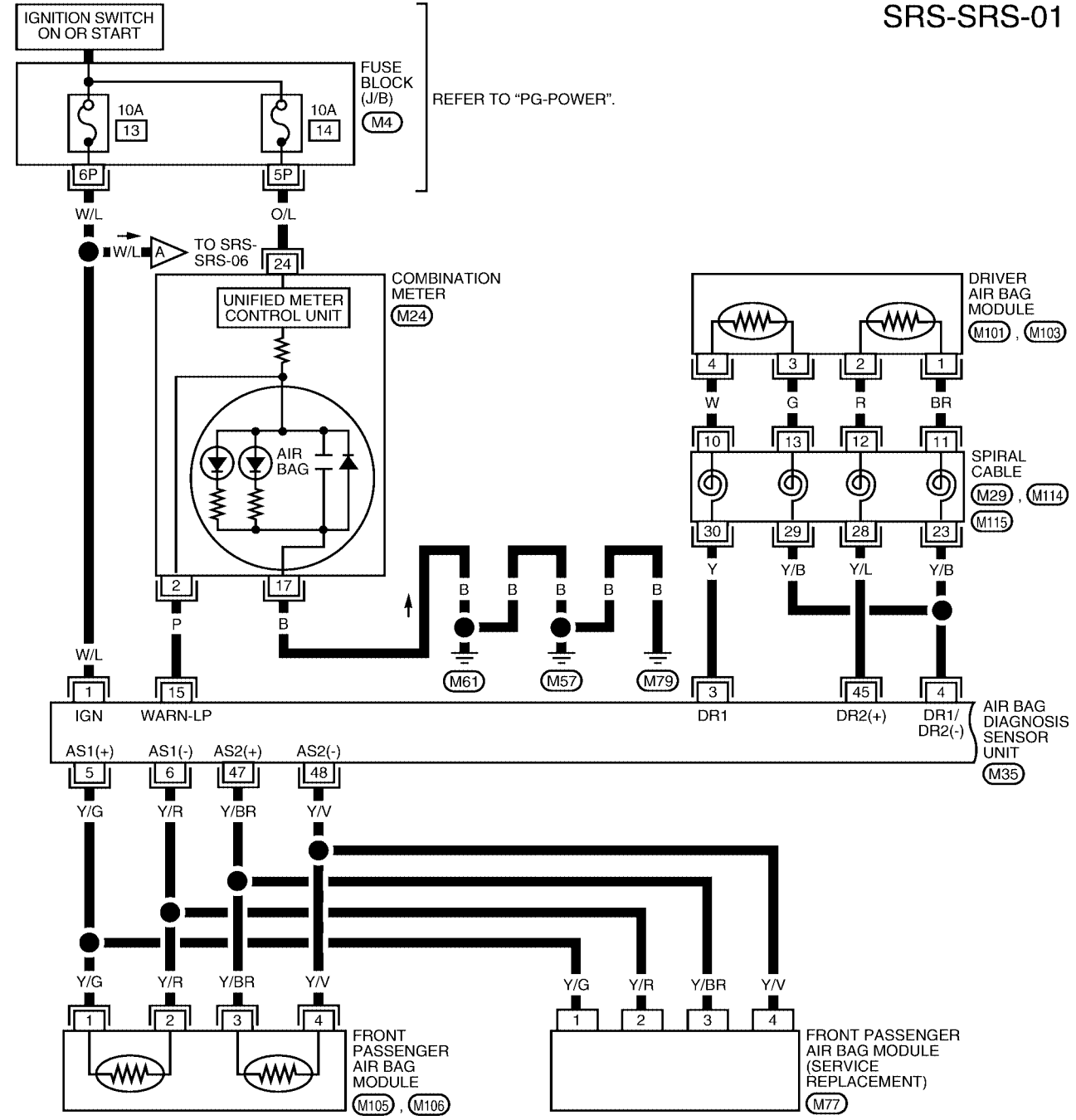

*: THIS CONNECTOR IS NOT SHOWN IN "HARNESS LAYOUT" OF PG SECTION.

WHWA0117E

TROUBLE DIAGNOSIS

SRS-SRS-02

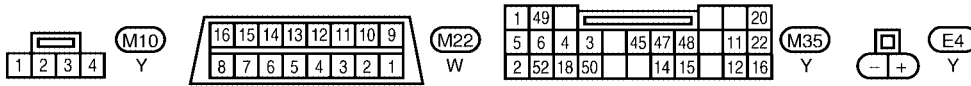
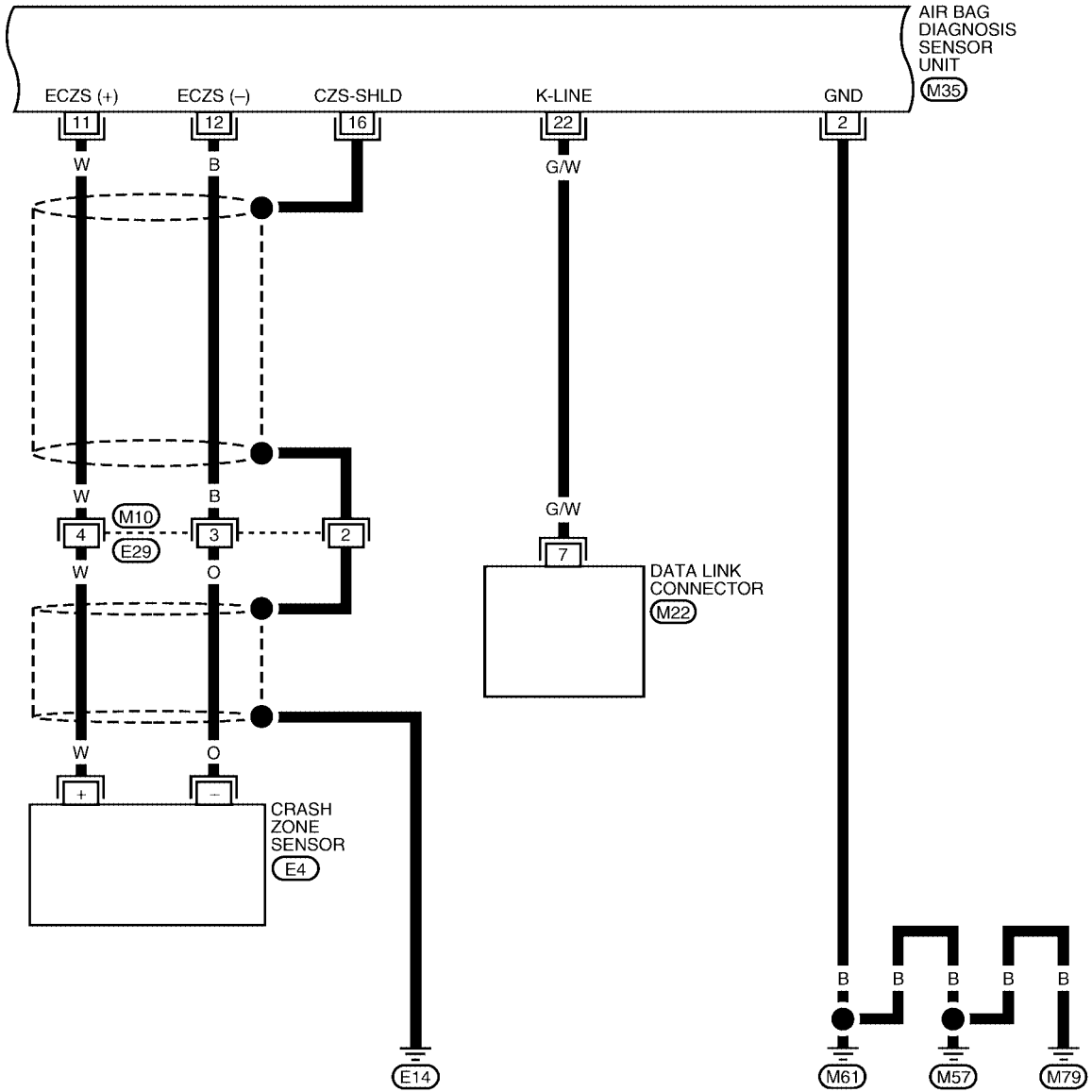

WHWA0118E

TROUBLE DIAGNOSIS

SRS-SRS-03

CA : WITH SIDE CURTAIN
AIR BAGS

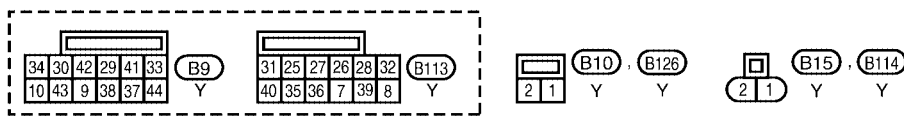
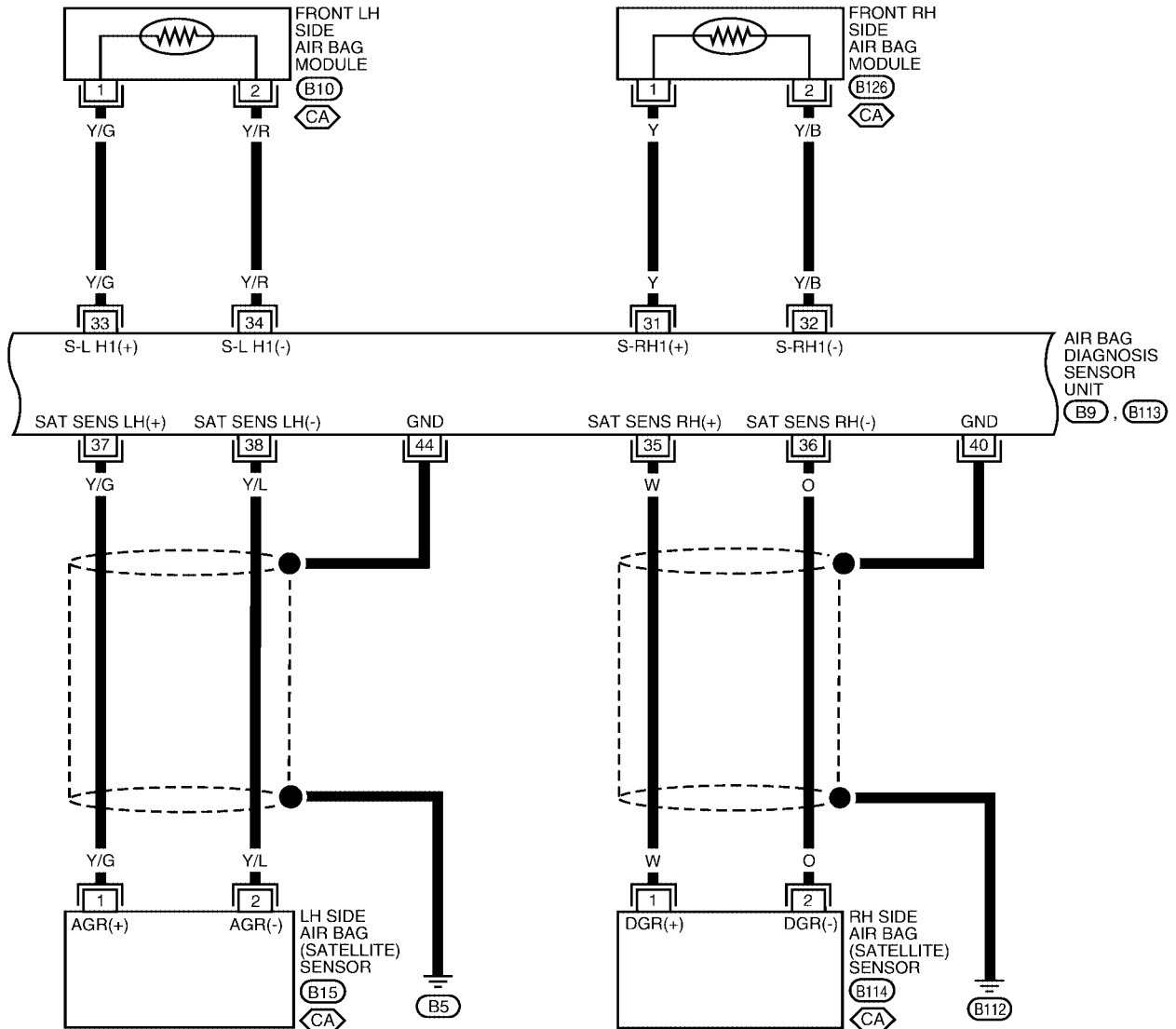

WHWA0123E

TROUBLE DIAGNOSIS

SRS-SRS-04

⬡CA⬡ : WITH SIDE CURTAIN AIR BAGS

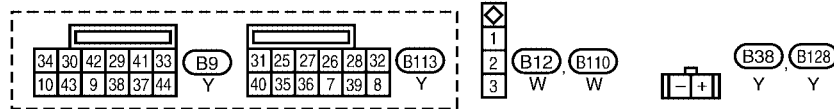
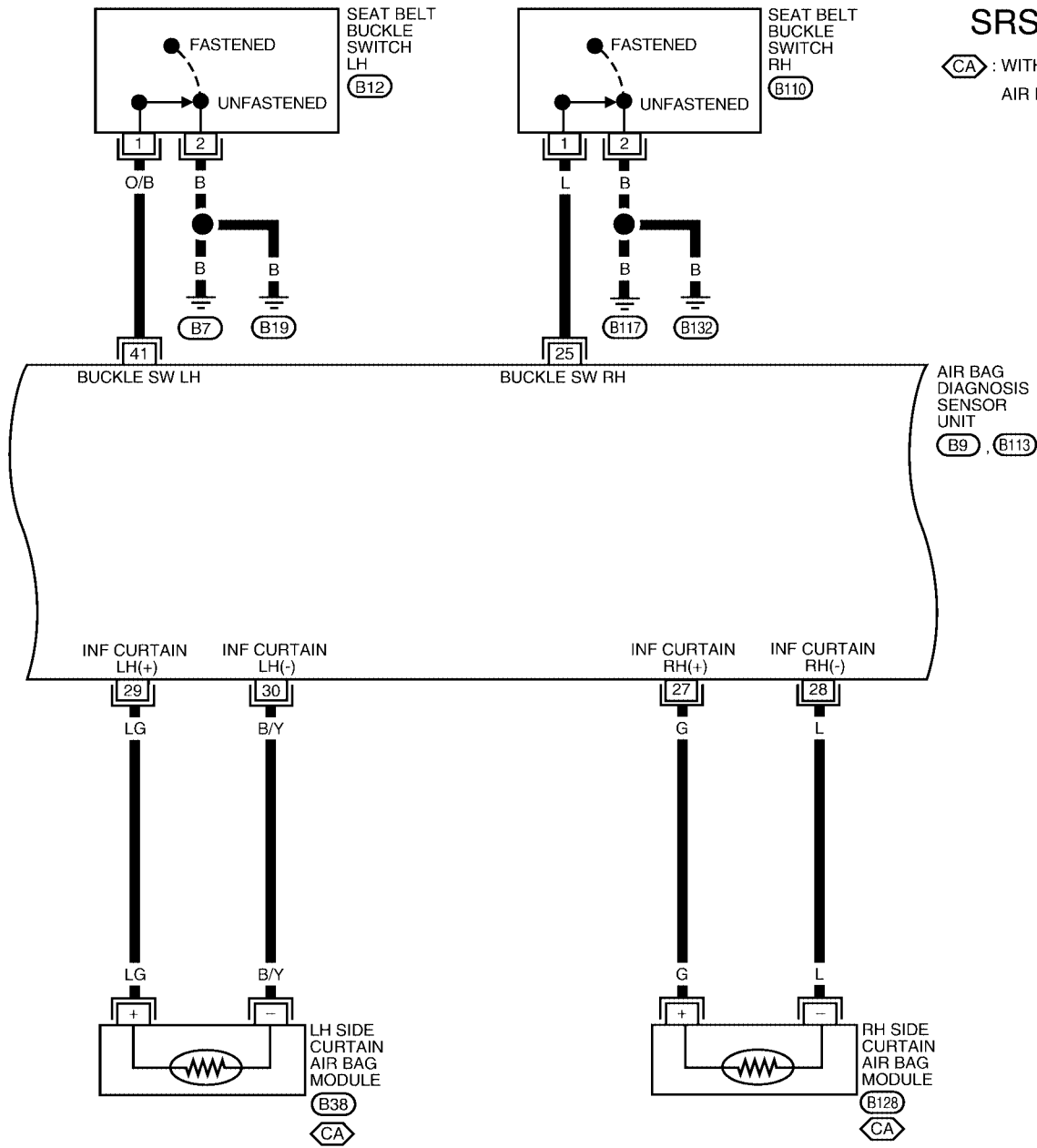

WHWA0124E

TROUBLE DIAGNOSIS

SRS-SRS-05

A
B
C
D
E
F
G
H
I
J
K
L
M

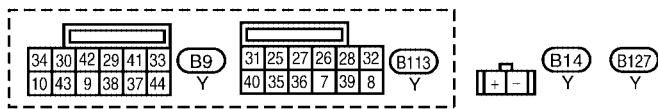
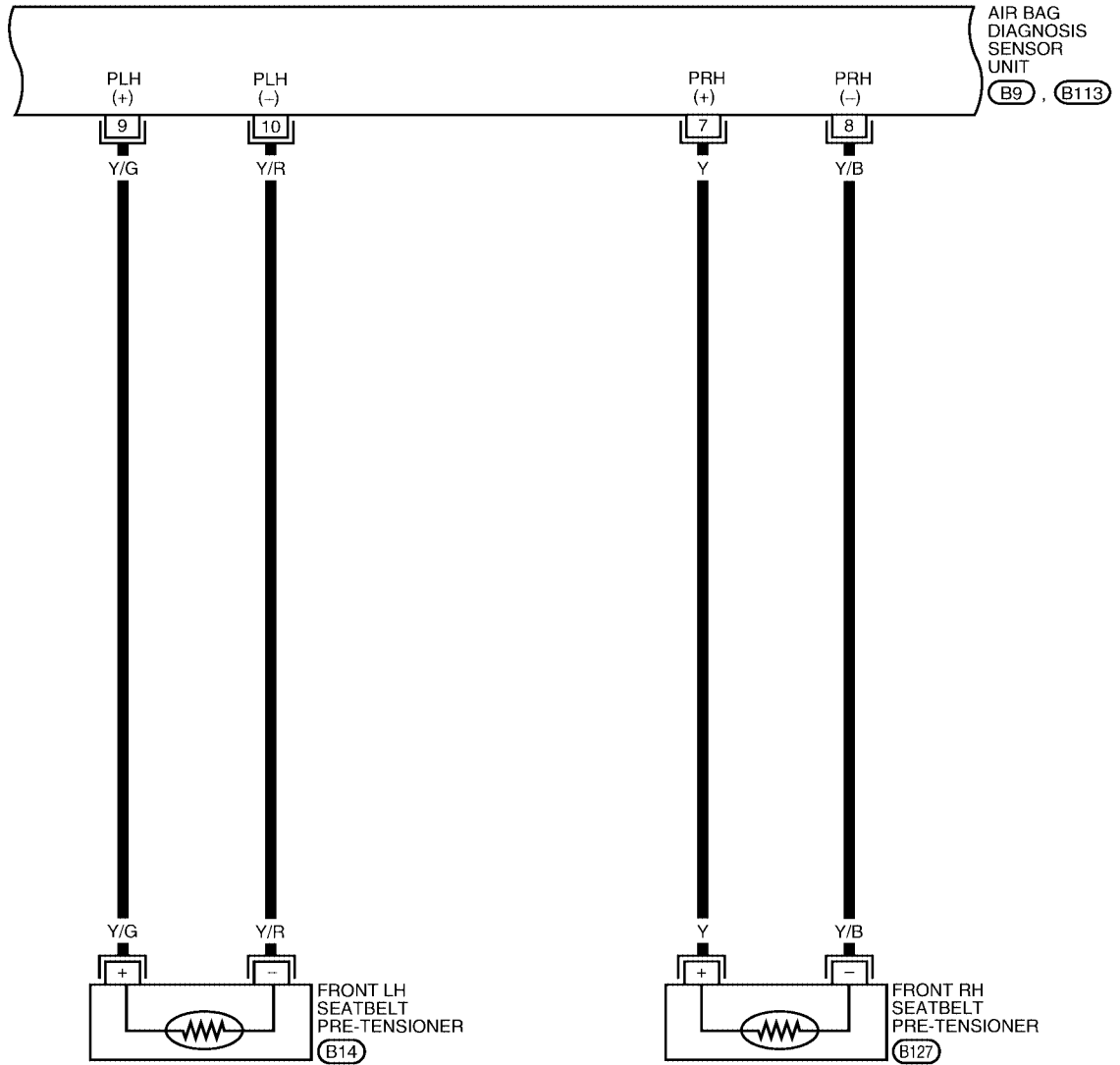

WHWA0125E

TROUBLE DIAGNOSIS

SRS-SRS-06

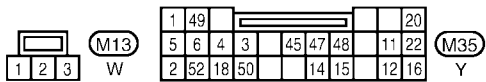
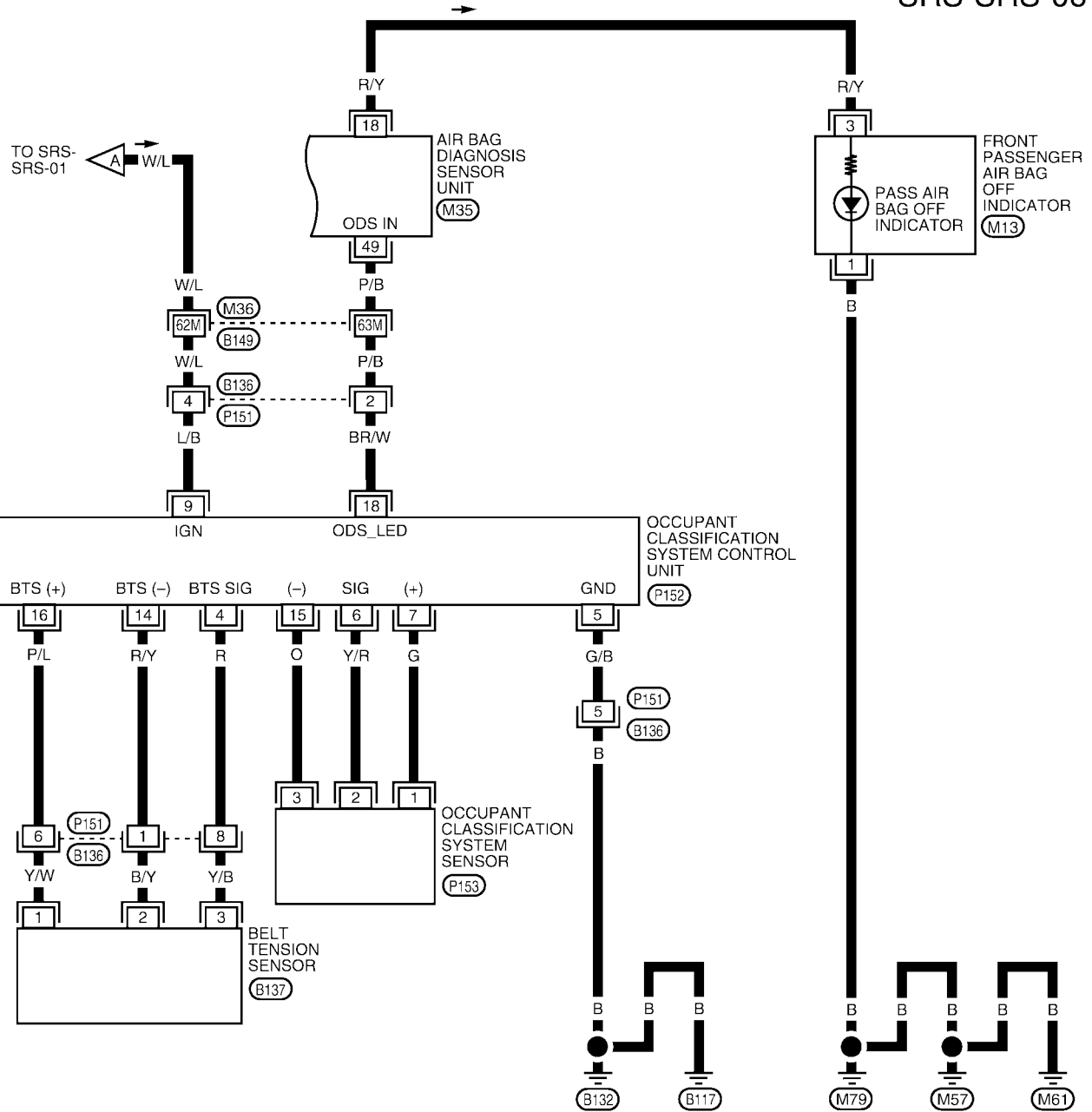

REFER TO THE FOLLOWING.
 (M36) - SUPER MULTIPLE JUNCTION (SMJ)

*: THIS CONNECTOR IS NOT SHOWN IN "HARNESS LAYOUT" OF PG SECTION.

WHWA0122E

TROUBLE DIAGNOSIS

CONSULT-II Function (AIR BAG)

EHS001B6

CONSULT-II can display each diagnostic item using the diagnostic test modes shown following.

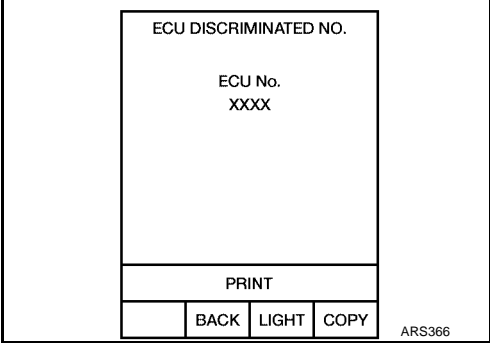
AIR BAG diagnostic mode	Description
SELF-DIAG [CURRENT]	A current Self-diagnosis result (also indicated by the number of warning lamp flashes in the Diagnosis mode) is displayed on the CONSULT-II screen in real time. This refers to a malfunctioning part requiring repairs.
SELF-DIAG [PAST]	Diagnosis results previously stored in the memory are displayed on the CONSULT-II screen. The stored results will remain until memory erasing is executed.
TROUBLE DIAG RECORD	With TROUBLE DIAG RECORD, diagnosis results previously erased by a reset operation can be displayed on the CONSULT-II screen.
ECU DISCRIMINATED NO.	<p>The air bag diagnosis sensor unit for each vehicle model is assigned with its own, individual classification number. This number will be displayed on the CONSULT-II screen, as shown. When replacing the air bag diagnosis sensor unit, refer to the part number for the compatibility. After installation, replacement with a correct unit can be checked by confirming this classification number on the CONSULT-II screen.</p> <p>For NISSAN MODEL A60, the air bag diagnosis sensor unit discriminated numbers assigned are F627 with front side and side curtain air bag modules and F611 without front side and side curtain air bag modules.</p> 

CONSULT-II Function

EHS00148

HOW TO CHANGE SELF-DIAGNOSIS MODE WITH CONSULT-II

From User Mode to Diagnosis Mode

After selecting "AIR BAG" on the "SELECT SYSTEM" screen, User mode automatically changes to Diagnosis mode.

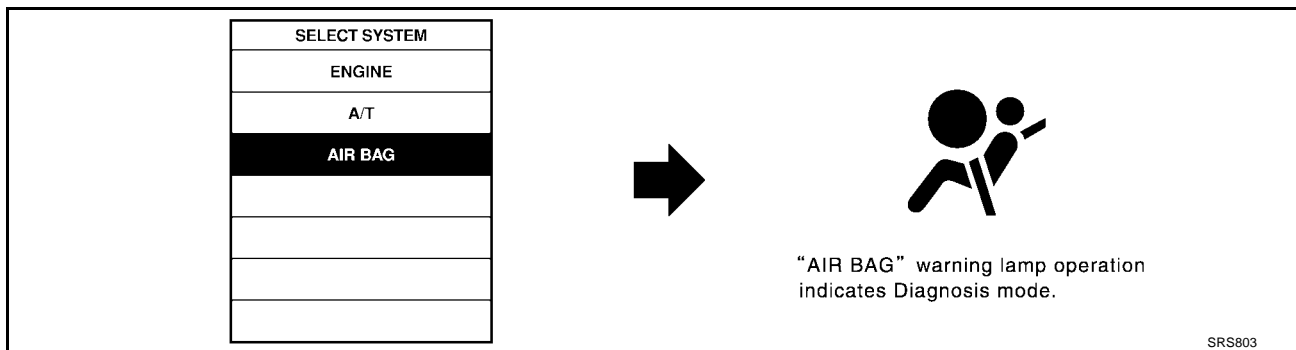

From Diagnosis Mode to User Mode

To return to User mode from Diagnosis mode, touch "BACK" key of CONSULT-II until "SELECT SYSTEM" appears, Diagnosis mode automatically changes to User mode.

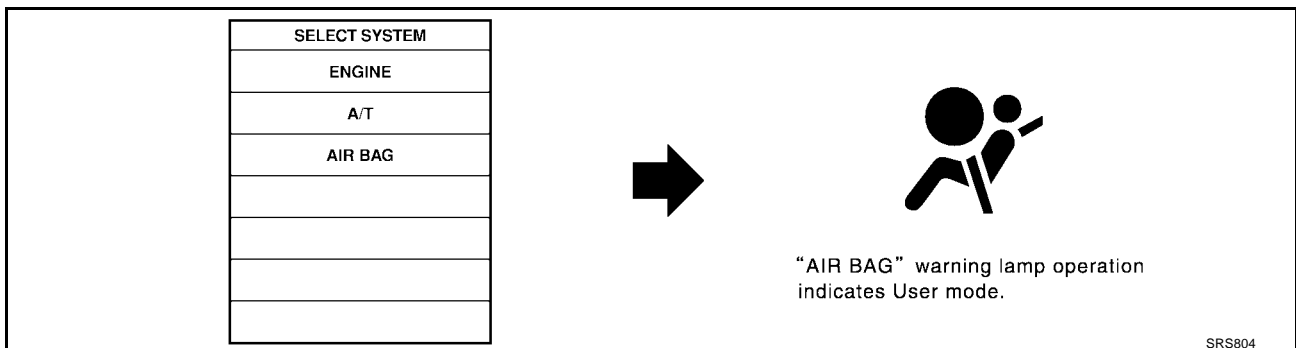

TROUBLE DIAGNOSIS

HOW TO ERASE SELF-DIAGNOSIS RESULTS

- “SELF-DIAG [CURRENT]”

A current self-diagnosis result is displayed on the CONSULT-II screen in real time.
After the malfunction is repaired completely, no malfunction is detected on “SELF-DIAG [CURRENT]”.

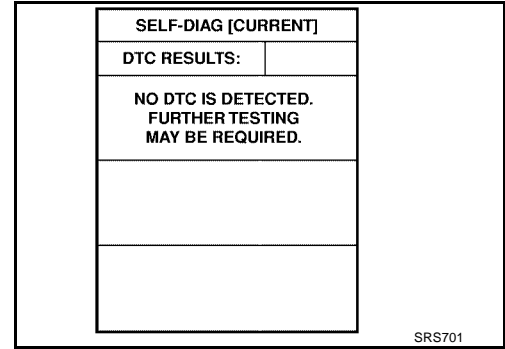

- “SELF-DIAG [PAST]”

Return to the “SELF-DIAG [CURRENT]” CONSULT-II screen by touching “BACK” key of CONSULT-II and select “SELF-DIAG [PAST]” in SELECT DIAG MODE. Touch “ERASE” in “SELF-DIAG [PAST]” mode.

NOTE:

If the memory of the malfunction in “SELF-DIAG [PAST]” is not erased, the User mode will continue to show the system malfunction by the operation of the warning lamp even if the malfunction is repaired completely.

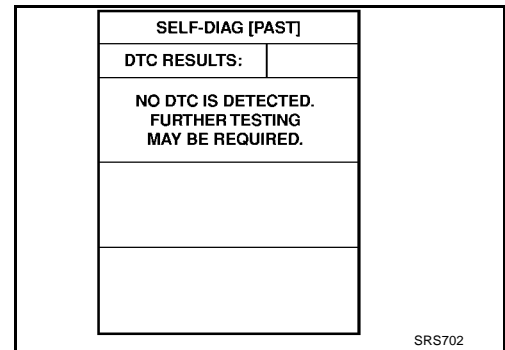

- “TROUBLE DIAG RECORD”

The memory of “TROUBLE DIAG RECORD” cannot be erased.

Self-Diagnosis Function (Without CONSULT-II)

EHS00149

- The reading of these results is accomplished using one of two modes — “User mode” and “Diagnosis mode”.
- After a malfunction is repaired, turn the ignition switch OFF for at least one second, then back ON. Diagnosis mode returns to the User mode. At that time, the self-diagnostic result is cleared.

HOW TO CHANGE SELF-DIAGNOSIS MODE

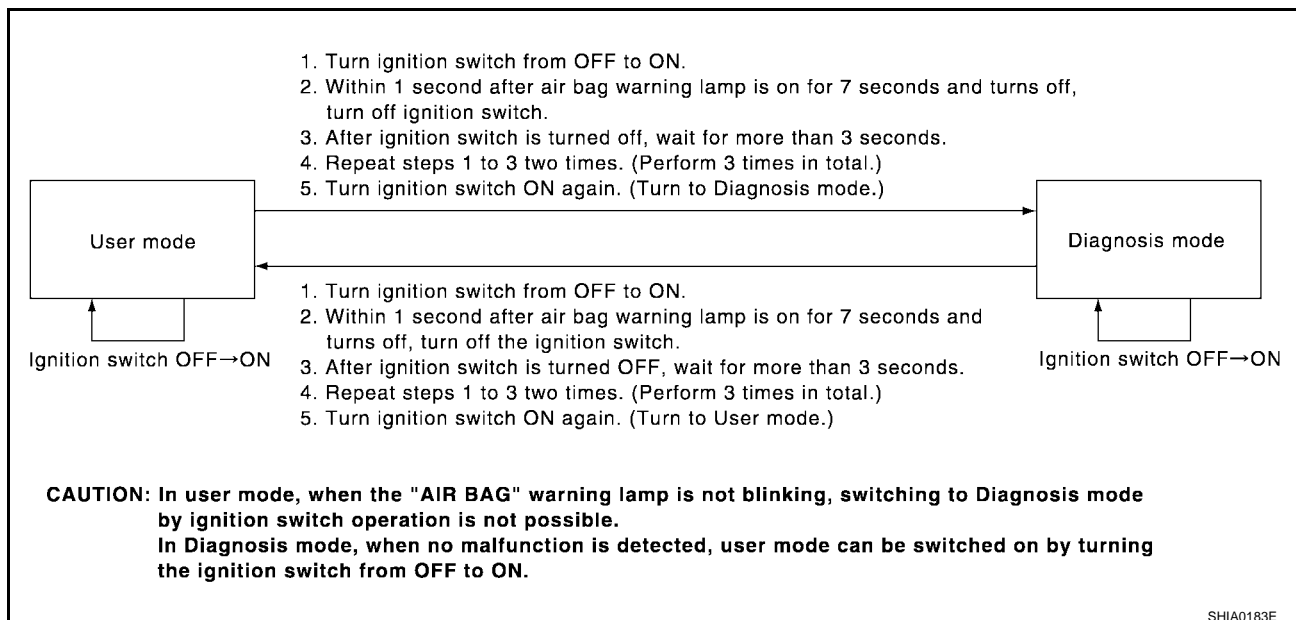

TROUBLE DIAGNOSIS

HOW TO ERASE SELF-DIAGNOSIS RESULTS

After a malfunction is repaired, turn the ignition switch OFF for at least one second, then back ON. Diagnosis mode returns to the User mode. At that time, the self-diagnostic result is cleared.

SRS Operation Check DIAGNOSTIC PROCEDURE 1

EHS0014A

Checking SRS Operation Using “AIR BAG” Warning Lamp—User Mode

1. Turn the ignition switch from OFF to ON, and check that the air bag warning lamp blinks.
2. Compare the SRS air bag warning lamp blinking pattern with the examples.

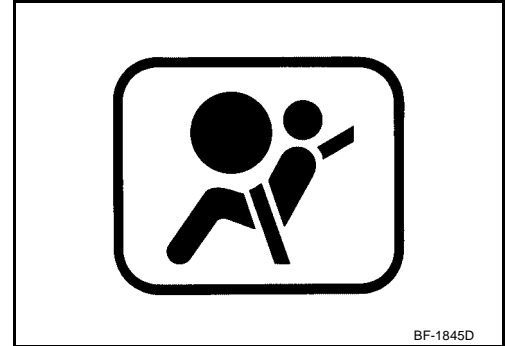

A

B

C

D

E

F

G

SRS

I

J



K

L

M

TROUBLE DIAGNOSIS

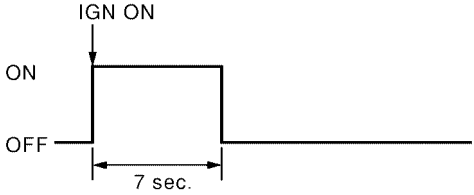
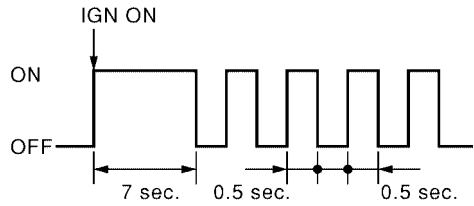
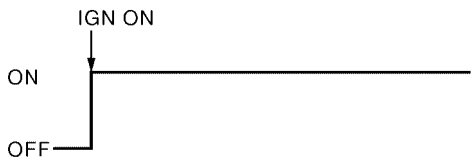
Warning lamp examples

"AIR BAG" warning lamp operation-User mode-	SRS condition	Reference item
 <p style="text-align: right;">SHIA0011E</p>	<ul style="list-style-type: none"> ● No malfunction is detected. ● No further action is necessary. 	—
 <p style="text-align: right;">SHIA0012E</p>	<ul style="list-style-type: none"> ● The system is malfunctioning and needs to be repaired as indicated. 	<p>Go to SRS-23, "DIAGNOSTIC PROCEDURE 2" or SRS-37, "DIAGNOSTIC PROCEDURE 6" .</p>
 <p style="text-align: right;">SHIA0013E</p>	<ul style="list-style-type: none"> ● Air bag is deployed. ● Seat belt pre-tensioner is deployed. ● Air bag diagnosis sensor unit is malfunctioning. ● Air bag power supply circuit is malfunctioning. ● SRS air bag warning lamp circuit is malfunctioning. 	<p>Go to SRS-67, "COLLISION DIAGNOSIS" .</p> <p>Go to SRS-42, "Trouble Diagnosis: "AIR BAG" Warning Lamp Does Not Turn Off" .</p>
 <p style="text-align: right;">SHIA0014E</p>	<ul style="list-style-type: none"> ● Air bag diagnosis sensor unit is malfunctioning. ● Air bag warning lamp circuit is malfunctioning. 	<p>Go to SRS-43, "Trouble Diagnosis: "AIR BAG" Warning Lamp Does Not Turn On" .</p>

TROUBLE DIAGNOSIS

EHS0014B

Trouble Diagnosis With CONSULT-II DIAGNOSTIC PROCEDURE 2

CAUTION:

If CONSULT-II is used with no connection of CONSULT-II CONVERTER, malfunction might be detected in self-diagnosis depending on control unit which carry out CAN communication.

1. Turn ignition switch OFF.
2. Connect CONSULT-II and CONSULT-II CONVERTER to the data link connector.

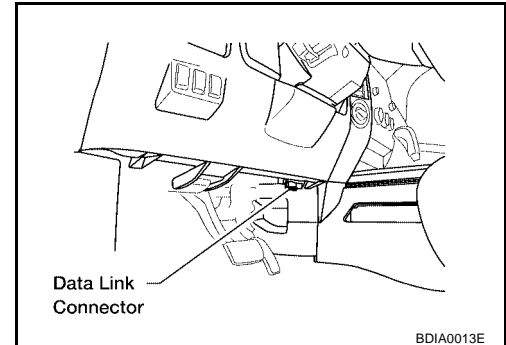

3. Turn ignition switch ON.
4. Touch "START (NISSAN BASED VHCL)".

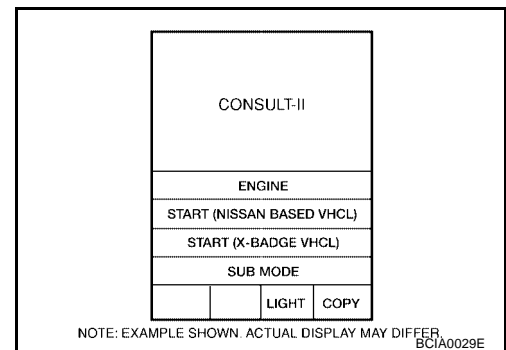

5. Touch "AIR BAG".
If "AIR BAG" is not indicated, refer to [GI-38, "CONSULT-II Data Link Connector \(DLC\) Circuit"](#).

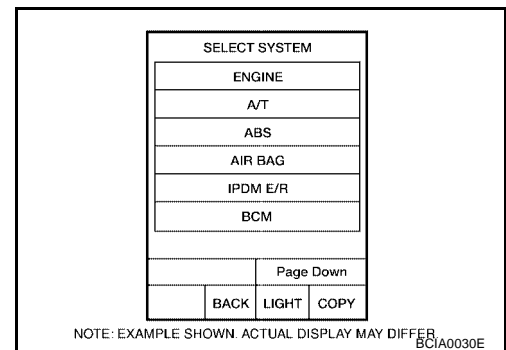

6. Touch "SELF-DIAG [CURRENT]".

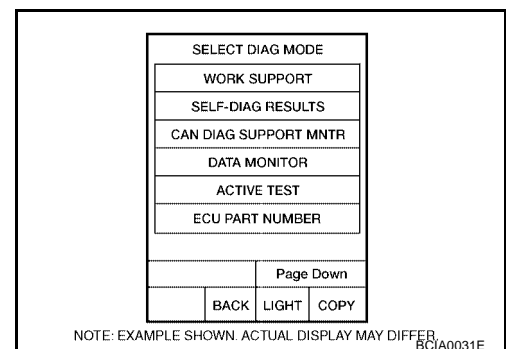

A
B
C
D
E
F
G
I
J
K
L
M

SRS

TROUBLE DIAGNOSIS

7. Diagnostic code is displayed on "SELF-DIAG [CURRENT]".

SELF-DIAG [CURRENT]
DTC RESULTS
DRIVER AIRBAG MODULE [OPEN] [B1049]

WHIA0151E

If no malfunction is detected on "SELF-DIAG [CURRENT]" even though malfunction is detected in "SRS Operation Check", refer to [SRS-31, "DIAGNOSTIC PROCEDURE 4 \(CONTINUED FROM DIAGNOSTIC PROCEDURE 2\)"](#), to diagnose the following cases:

- Self-diagnostic result "SELF-DIAG [PAST]" (previously stored in the memory) might not be erased after repair.
- The SRS system malfunctions intermittently.

SELF-DIAG [CURRENT]
DTC RESULTS:
NO DTC IS DETECTED. FURTHER TESTING MAY BE REQUIRED.

SRS701

TROUBLE DIAGNOSIS

CONSULT-II Diagnostic Code Chart ("SELF-DIAG [CURRENT]")

Diagnostic item	Explanation	Repair order Recheck SRS at each replacement
NO DTC IS DETECTED	When malfunction is indicated by the "AIR BAG" warning lamp in User mode. <ul style="list-style-type: none"> ● Low battery voltage (Less than 9V) ● Self-diagnostic result "SELF-DIAG [PAST]" (previously stored in the memory) might not be erased after repair. ● Intermittent malfunction has been detected in the past. 	<ul style="list-style-type: none"> ● Go to SRS-28. "DIAGNOSTIC PROCEDURE 3" . ● Go to SRS-31. "DIAGNOSTIC PROCEDURE 4 (CONTINUED FROM DIAGNOSTIC PROCEDURE 2)" . ● Go to SRS-31. "DIAGNOSTIC PROCEDURE 5" .
	● No malfunction is detected.	—
DRIVER AIRBAG MODULE [OPEN] [B1049] or [B1054]	● Driver air bag module circuit is open (including the spiral cable).	1. Visually check the wiring harness connection. 2. Replace the harness if it has visible damage.
DRIVER AIRBAG MODULE [VB-SHORT] [B1050] or [B1055]	● Driver air bag module circuit is shorted to some power supply circuit (including the spiral cable).	3. Replace driver air bag module. (Before disposal, it must be deployed.)
DRIVER AIRBAG MODULE [GND-SHORT] [B1051] or [B1056]	● Driver air bag module circuit is shorted to ground (including the spiral cable).	4. Replace the spiral cable.
DRIVER AIRBAG MODULE [SHORT] [B1052] or [B1057]	● Driver air bag module circuits are shorted to each other.	5. Replace the air bag diagnosis sensor unit. 6. Replace the related harness.
ASSIST A/B MODULE [OPEN] [B1065] or [B1070]	● Front passenger air bag module circuit is open.	1. Visually check the wiring harness connection.
ASSIST A/B MODULE [VB-SHORT] [B1066] or [B1071]	● Front passenger air bag module circuit is shorted to some power supply circuit.	2. Replace the harness if it has visible damage.
ASSIST A/B MODULE [GND-SHORT] [B1067] or [B1072]	● Front passenger air bag module circuit is shorted to ground.	3. Replace front passenger air bag module. (Before disposal, it must be deployed.)
ASSIST A/B MODULE [SHORT] [B1068] or [B1073]	● Front passenger air bag module circuits are shorted to each other.	4. Replace the air bag diagnosis sensor unit. 5. Replace the related harness.
CRASH ZONE SEN [UNIT FAIL] [B1033] or [B1034] CRASH ZONE SEN [COMM FAIL] [B1035]	● Crash zone sensor	1. Visually check the wiring harness connection. 2. Replace the harness if it has visible damage. 3. Replace the crash zone sensor. 4. Replace the air bag diagnosis sensor unit. 5. Replace the related harness.
SIDE MODULE LH [OPEN] [B1134]	● Front LH side air bag module circuit is open.	1. Visually check the wiring harness connection.
SIDE MODULE LH [VB-SHORT] [B1135]	● Front LH side air bag module circuit is shorted to some power supply circuit.	2. Replace the harness if it has visible damage.
SIDE MODULE LH [GND-SHORT] [B1136]	● Front LH side air bag module circuit is shorted to ground.	3. Replace front LH seat back assembly (front LH side air bag module). (Before disposal, it must be deployed.)
SIDE MODULE LH [SHORT] [B1137]	● Front LH side air bag module circuits are shorted to each other.	4. Replace the air bag diagnosis sensor unit. 5. Replace the related harness.

A
B
C
D
E
F
G
SRS

I
J
K
L
M

TROUBLE DIAGNOSIS

Diagnostic item	Explanation	Repair order Recheck SRS at each replacement
SIDE MODULE RH [OPEN] [B1129]	<ul style="list-style-type: none"> ● Front RH side air bag module circuit is open. 	<ol style="list-style-type: none"> 1. Visually check the wiring harness connection. 2. Replace the harness if it has visible damage. 3. Replace front RH seat back assembly (front RH side air bag module). (Before disposal, it must be deployed.) 4. Replace the air bag diagnosis sensor unit. 5. Replace the related harness.
SIDE MODULE RH [VB-SHORT] [B1130]	<ul style="list-style-type: none"> ● Front RH side air bag module circuit is shorted to some power supply circuit. 	
SIDE MODULE RH [GND-SHORT] [B1131]	<ul style="list-style-type: none"> ● Front RH side air bag module circuit is shorted to ground. 	
SIDE MODULE RH [SHORT] [B1132]	<ul style="list-style-type: none"> ● Front RH side air bag module circuits are shorted to each other. 	
SATELLITE SENS LH [UNIT FAIL] [B1118] or [B1119] SATELLITE SENS LH [COMM FAIL] [B1120]	<ul style="list-style-type: none"> ● LH side air bag (satellite) sensor 	<ol style="list-style-type: none"> 1. Visually check the wiring harness connection. 2. Replace the harness if it has visible damage. 3. Replace the LH side air bag (satellite) sensor. 4. Replace the air bag diagnosis sensor unit. 5. Replace the related harness.
SATELLITE SENS RH [UNIT FAIL] [B1113] or [B1114] SATELLITE SENS RH [COMM FAIL] [B1115]	<ul style="list-style-type: none"> ● RH side air bag (satellite) sensor 	<ol style="list-style-type: none"> 1. Visually check the wiring harness connection. 2. Replace the harness if it has visible damage. 3. Replace the RH side air bag (satellite) sensor. 4. Replace the air bag diagnosis sensor unit. 5. Replace the related harness.
PRE-TEN FRONT LH [OPEN] [B1086]	<ul style="list-style-type: none"> ● The circuit for front LH seat belt pre-tensioner is open. 	<ol style="list-style-type: none"> 1. Visually check the wiring harness connections. 2. Replace the harness if it has visible damage. 3. Replace front LH seat belt pre-tensioner. (Before disposal, it must be deployed.) 4. Replace the air bag diagnosis sensor unit. 5. Replace the related harness.
PRE-TEN FRONT LH [VB-SHORT] [B1087]	<ul style="list-style-type: none"> ● The circuit for front LH seat belt pre-tensioner is shorted to some power supply circuit. 	
PRE-TEN FRONT LH [GND-SHORT] [B1088]	<ul style="list-style-type: none"> ● The circuit for front LH seat belt pre-tensioner is shorted to ground. 	
PRE-TEN FRONT LH [SHORT] [B1089]	<ul style="list-style-type: none"> ● The circuits for the front LH seat belt pre-tensioner are shorted to each other. 	
PRE-TEN FRONT RH [OPEN] [B1081]	<ul style="list-style-type: none"> ● The circuit for front RH seat belt pre-tensioner is open. 	<ol style="list-style-type: none"> 1. Visually check the wiring harness connections. 2. Replace the harness if it has visible damage. 3. Replace front RH seat belt pre-tensioner. (Before disposal, it must be deployed.) 4. Replace the air bag diagnosis sensor unit. 5. Replace the related harness.
PRE-TEN FRONT RH [VB-SHORT] [B1082]	<ul style="list-style-type: none"> ● The circuit for front RH seat belt pre-tensioner is shorted to some power supply circuit. 	
PRE-TEN FRONT RH [GND-SHORT] [B1083]	<ul style="list-style-type: none"> ● The circuit for front RH seat belt pre-tensioner is shorted to ground. 	
PRE-TEN FRONT RH [SHORT] [B1084]	<ul style="list-style-type: none"> ● The circuits for the front RH seat belt pre-tensioner are shorted to each other. 	

TROUBLE DIAGNOSIS

Diagnostic item	Explanation	Repair order Recheck SRS at each replacement	A
CURTAIN MODULE LH [OPEN] [B1150]	<ul style="list-style-type: none"> The LH side curtain air bag module circuit is open. 	<ol style="list-style-type: none"> 1. Visually check the wiring harness connection. 2. Replace the harness if it has visible damage. 3. Replace LH side curtain air bag module. (Before disposal, it must be deployed.) 4. Replace the air bag diagnosis sensor unit. 5. Replace the related harness. 	B
CURTAIN MODULE LH [VB-SHORT] [B1151]	<ul style="list-style-type: none"> The LH side curtain air bag module circuit is shorted to some power supply circuits. 		C
CURTAIN MODULE LH [GND-SHORT] [B1152]	<ul style="list-style-type: none"> The LH side curtain air bag module circuit is shorted to ground. 		D
CURTAIN MODULE LH [SHORT] [B1153]	<ul style="list-style-type: none"> The circuits for the LH side curtain air bag module are shorted to each other. 		E
CURTAIN MODULE RH [OPEN] [B1145]	<ul style="list-style-type: none"> The RH side curtain air bag module circuit is open. 	<ol style="list-style-type: none"> 1. Visually check the wiring harness connection. 2. Replace the harness if it has visible damage. 3. Replace RH side curtain air bag module. (Before disposal, it must be deployed.) 4. Replace the air bag diagnosis sensor unit. 5. Replace the related harness. 	F
CURTAIN MODULE RH [VB-SHORT] [B1146]	<ul style="list-style-type: none"> The RH side curtain air bag module circuit is shorted to some power supply circuits. 		G
CURTAIN MODULE RH [GND-SHORT] [B1147]	<ul style="list-style-type: none"> The RH side curtain air bag module circuit is shorted to ground. 		SRS
CURTAIN MODULE RH [SHORT] [B1148]	<ul style="list-style-type: none"> The circuits for the RH side curtain air bag module are shorted to each other. 		I
CONTROL UNIT [B1XXX]	<ul style="list-style-type: none"> Air bag diagnosis sensor unit is malfunctioning. 	<ol style="list-style-type: none"> 1. Visually check the wiring harness connection. 2. Replace the diagnosis sensor unit. 	J
OCCUPANT SENS C/U [UNIT FAIL] [B1017], [B1020] or [B1021]	<ul style="list-style-type: none"> Occupant classification system is malfunctioning. 	<ol style="list-style-type: none"> 1. Replace RH front seat cushion/occupant classification system control unit assembly. 	K
OCCUPANT SENS C/U [COMM FAIL] [B1022]	<ul style="list-style-type: none"> Communication between the occupant classification system control unit and air bag diagnosis sensor unit is interrupted. 	<ol style="list-style-type: none"> 1. Visually check the wiring harness connection. 2. Replace the harness if it has visible damage. 3. Replace RH front seat cushion/occupant classification system control unit assembly. 4. Replace the air bag diagnosis sensor unit. 5. Replace the related harness. 	L
OCCUPANT SENS [UNIT FAIL] [B1018]	<ul style="list-style-type: none"> Occupant classification sensor is malfunctioning. 	<ol style="list-style-type: none"> 1. Replace RH front seat cushion/occupant classification system control unit assembly. 	M

TROUBLE DIAGNOSIS

Diagnostic item	Explanation	Repair order Recheck SRS at each replacement
BELT TENSION SENS [UNIT FAIL] [B1019]	<ul style="list-style-type: none"> ● Belt tension sensor is malfunctioning. 	<ol style="list-style-type: none"> 1. Visually check the wiring harness connection. 2. Replace the harness if it has visible damage. 3. Replace RH front seat belt assembly. 4. Replace RH front seat cushion/ occupant classification system control unit assembly.
PASS A/B INDCTR CKT [B1023]	<ul style="list-style-type: none"> ● Front passenger air bag off indicator is malfunctioning. 	<ol style="list-style-type: none"> 1. Visually check the wiring harness connection. 2. Replace the harness if it has visible damage. 3. Replace front passenger air bag off indicator. 4. Replace the air bag diagnosis sensor unit. 5. Replace the related harness.

NOTE:

Follow the procedures in numerical order when repairing malfunctioning parts. Confirm whether malfunction is eliminated using air bag warning lamp or CONSULT-II each time repair is finished. If malfunction is still observed, proceed to the next step. When malfunction is eliminated, further repair work is not required.

DIAGNOSTIC PROCEDURE 3

Final Check of SRS Using CONSULT-II—Diagnosis Mode

CAUTION:

If CONSULT-II is used with no connection of CONSULT-II CONVERTER, malfunction might be detected in self-diagnosis depending on control unit which carry out CAN communication.

1. After repairing SRS, connect both battery cables.
2. Connect CONSULT-II and CONSULT-II CONVERTER to data link connector.
3. Turn ignition switch ON.

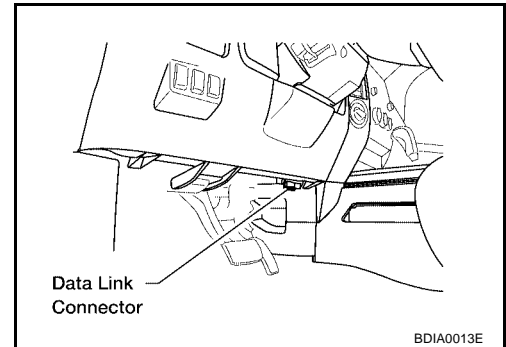

4. Touch "START (NISSAN BASED VHCL)".

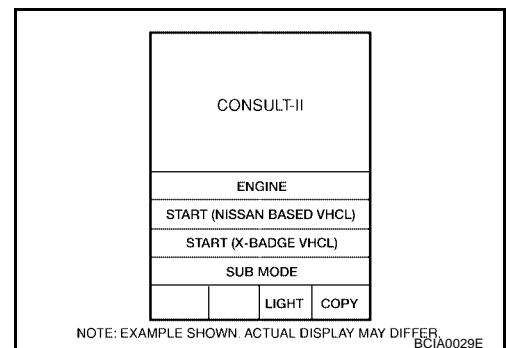

5. Touch "AIR BAG".

TROUBLE DIAGNOSIS

If "AIR BAG" is not indicated, refer to [GI-38, "CONSULT-II Data Link Connector \(DLC\) Circuit"](#).

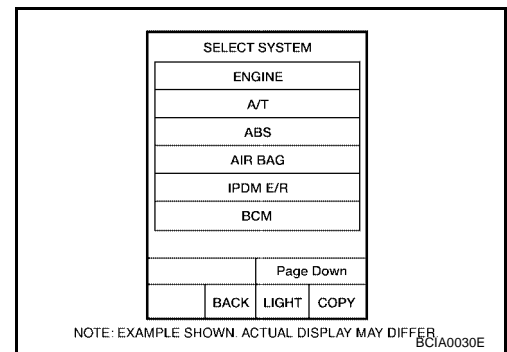

A
B
C
D
E
F
G

6. Touch "SELF-DIAG [CURRENT]".

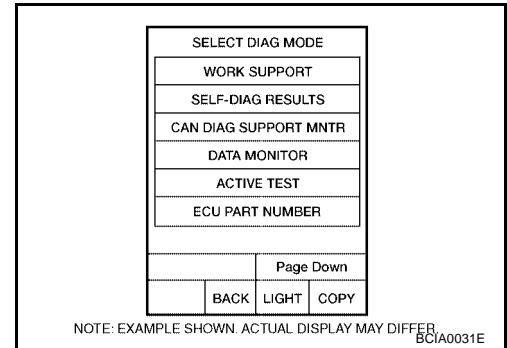

7. If no malfunction is detected on "SELF-DIAG [CURRENT]", repair of SRS is completed. Go to step 8.
If any malfunction is detected on "SELF-DIAG [CURRENT]", the malfunctioning part is not repaired completely or another malfunctioning part is detected. Go to [SRS-23, "DIAGNOSTIC PROCEDURE 2"](#), and repair malfunctioning part completely.

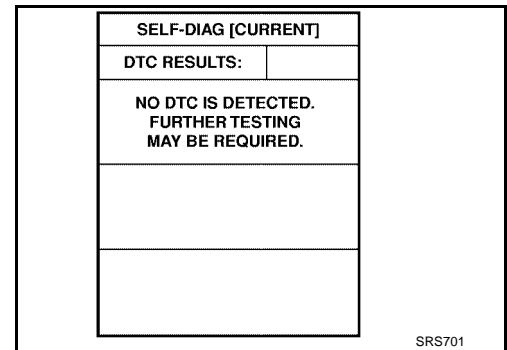

SRS

I
J
K
L
M

8. Touch "ERASE".

NOTE:
Touch "ERASE" to clear the memory of the malfunction ("SELF-DIAG [PAST]").
If the memory of the malfunction in "SELF-DIAG [PAST]" is not erased, the User mode shows the system malfunction by the operation of the warning lamp even if the malfunction is repaired completely.

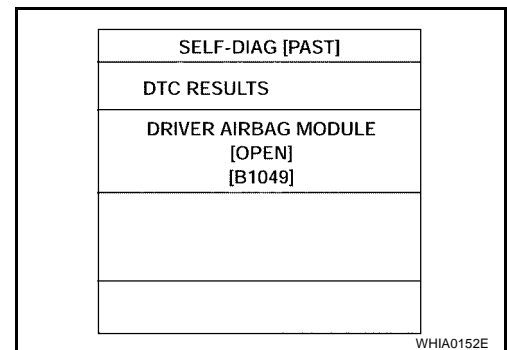

9. Touch "BACK" key of CONSULT-II to "SELECT DIAG MODE" screen. Touch "SELF-DIAG [PAST]".

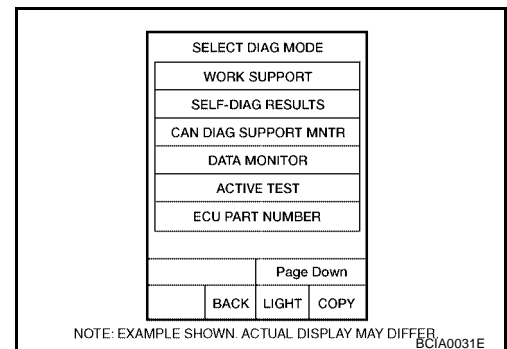

TROUBLE DIAGNOSIS

10. Check that no malfunction is detected on "SELF-DIAG [PAST]".
11. Touch "BACK" key of CONSULT-II until "SELECT SYSTEM" appears in order to return to User mode from Diagnosis mode.
12. Turn ignition switch OFF then turn off and disconnect CONSULT-II.
13. Go to [SRS-21, "Checking SRS Operation Using "AIR BAG" Warning Lamp—User Mode"](#) .

SELF-DIAG [PAST]	
DTC RESULTS:	
NO DTC IS DETECTED. FURTHER TESTING MAY BE REQUIRED.	

SRS702

TROUBLE DIAGNOSIS

DIAGNOSTIC PROCEDURE 4 (CONTINUED FROM DIAGNOSTIC PROCEDURE 2)

Check SRS Repair History

1. CONSIDER POSSIBILITY THAT SELF-DIAGNOSTIC RESULT WAS NOT ERASED AFTER REPAIR

Check repair history of the SRS.

Have any previous repairs been made to the SRS?

- Yes >> Self-diagnostic result "SELF-DIAG [PAST]" (previously stored in the memory) might not be erased after repair. Go to [SRS-28, "DIAGNOSTIC PROCEDURE 3"](#).
- No >> Go to [SRS-23, "DIAGNOSTIC PROCEDURE 2"](#).

DIAGNOSTIC PROCEDURE 5

Check SRS Intermittent Malfunction Using CONSULT-II—Diagnosis Mode

CAUTION:

If CONSULT-II is used with no connection of CONSULT-II CONVERTER, malfunction might be detected in self-diagnosis depending on control unit which carry out CAN communication.

1. Turn ignition switch OFF.
2. Connect CONSULT-II and CONSULT-II CONVERTER to data link connector.

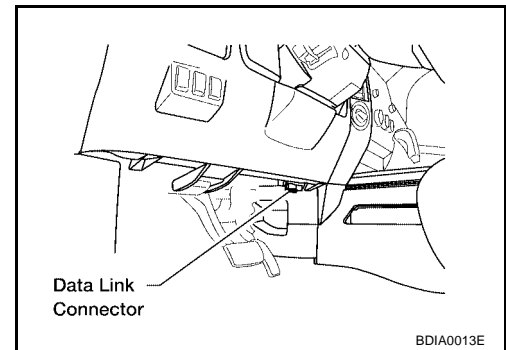

3. Turn ignition switch ON.
4. Touch "START (NISSAN BASED VHCL)".

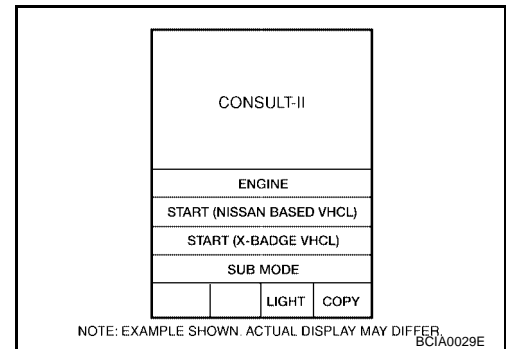

5. Touch "AIR BAG".
If "AIR BAG" is not indicated, refer to [GI-38, "CONSULT-II Data Link Connector \(DLC\) Circuit"](#).

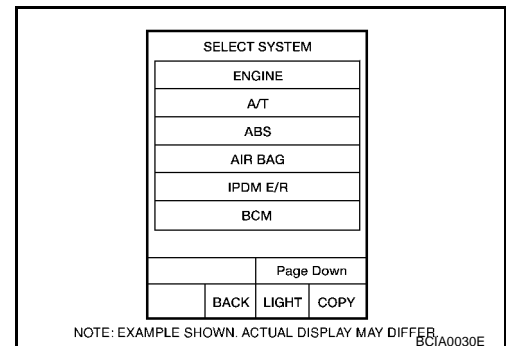

TROUBLE DIAGNOSIS

6. Touch "SELF-DIAG [PAST]".

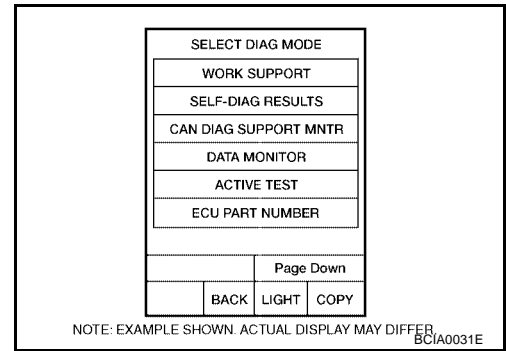

7. If diagnostic codes are displayed on "SELF-DIAG [PAST]", go to step 10.

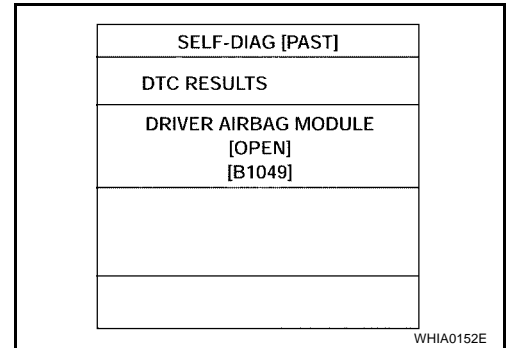

If no malfunction is detected on "SELF-DIAG [PAST]", touch "BACK" and go back to "SELECT DIAG MODE".

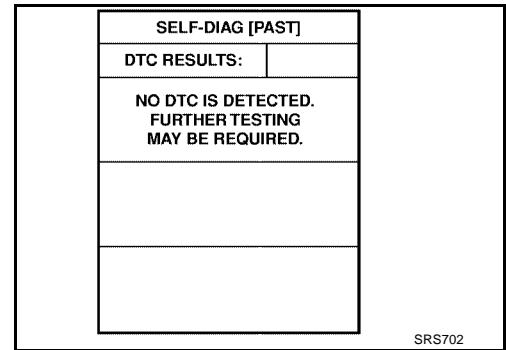

8. Touch "TROUBLE DIAG RECORD".

NOTE:

With "TROUBLE DIAG RECORD", diagnosis results previously erased by a reset operation can be displayed.

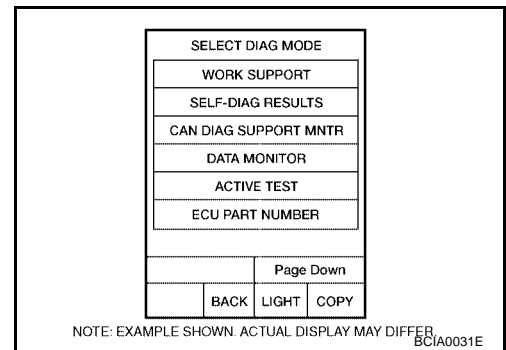

9. Diagnostic code is displayed on "TROUBLE DIAG RECORD".

10. Touch "PRINT".

11. Compare diagnostic codes to [SRS-33, "CONSULT-II Diagnostic Code Chart \("SELF-DIAG \[PAST\]" or "TROUBLE DIAG RECORD"\)"](#).

12. Touch "BACK" key of CONSULT-II until "SELECT SYSTEM" appears.

13. Turn ignition switch OFF, then turn off and disconnect CONSULT-II, and both battery cables.

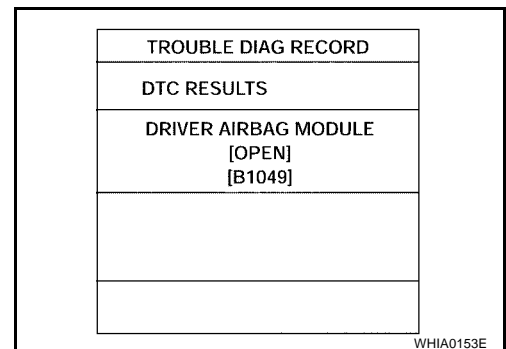

TROUBLE DIAGNOSIS

14. Repair the system as outlined by the "Repair order" in "Intermittent Malfunction Diagnostic Code Chart", that corresponds to the self-diagnostic result. For replacement procedure of component parts, refer to the Removal and Installation procedure for the appropriate component.
15. Go to [SRS-28, "DIAGNOSTIC PROCEDURE 3"](#) , for final checking.

CONSULT-II Diagnostic Code Chart ("SELF-DIAG [PAST]" or "TROUBLE DIAG RECORD")

Diagnostic item	Explanation	Repair order Recheck SRS at each replacement
NO DTC IS DETECTED	When malfunction is indicated by the "AIR BAG" warning lamp in User mode. <ul style="list-style-type: none"> ● Low battery voltage (Less than 9V) ● Self-diagnostic result "SELF-DIAG [PAST]" (previously stored in the memory) might not be erased after repair. ● Intermittent malfunction has been detected in the past. 	<ul style="list-style-type: none"> ● Go to SRS-28, "DIAGNOSTIC PROCEDURE 3" . ● Go to SRS-31, "DIAGNOSTIC PROCEDURE 4 (CONTINUED FROM DIAGNOSTIC PROCEDURE 2)" . ● Go to SRS-31, "DIAGNOSTIC PROCEDURE 5" .
	● No malfunction is detected.	—
DRIVER AIRBAG MODULE [OPEN] [B1049] or [B1054]	● Driver air bag module circuit is open (including the spiral cable).	<ol style="list-style-type: none"> 1. Visually check the wiring harness connection. 2. Replace the harness if it has visible damage.
DRIVER AIRBAG MODULE [VB-SHORT] [B1050] or [B1055]	● Driver air bag module circuit is shorted to some power supply circuit (including the spiral cable).	<ol style="list-style-type: none"> 3. Replace driver air bag module. (Before disposal, it must be deployed.)
DRIVER AIRBAG MODULE [GND-SHORT] [B1051] or [B1056]	● Driver air bag module circuit is shorted to ground (including the spiral cable).	<ol style="list-style-type: none"> 4. Replace the spiral cable.
DRIVER AIRBAG MODULE [SHORT] [B1052] or [B1057]	● Driver air bag module circuits are shorted to each other.	<ol style="list-style-type: none"> 5. Replace the air bag diagnosis sensor unit. 6. Replace the related harness.
ASSIST A/B MODULE [OPEN] [B1065] or [B1070]	● Front passenger air bag module circuit is open.	<ol style="list-style-type: none"> 1. Visually check the wiring harness connection. 2. Replace the harness if it has visible damage.
ASSIST A/B MODULE [VB-SHORT] [B1066] or [B1071]	● Front passenger air bag module circuit is shorted to some power supply circuit.	<ol style="list-style-type: none"> 3. Replace front passenger air bag module. (Before disposal, it must be deployed.)
ASSIST A/B MODULE [GND-SHORT] [B1067] or [B1072]	● Front passenger air bag module circuit is shorted to ground.	<ol style="list-style-type: none"> 4. Replace the air bag diagnosis sensor unit.
ASSIST A/B MODULE [SHORT] [B1068] or [B1073]	● Front passenger air bag module circuits are shorted to each other.	<ol style="list-style-type: none"> 5. Replace the related harness.
CRASH ZONE SEN [UNIT FAIL] [B1033] or [B1034] CRASH ZONE SEN [COMM FAIL] [B1035]	● Crash zone sensor	<ol style="list-style-type: none"> 1. Visually check the wiring harness connection. 2. Replace the harness if it has visible damage. 3. Replace the crash zone sensor. 4. Replace the air bag diagnosis sensor unit. 5. Replace the related harness.

TROUBLE DIAGNOSIS

Diagnostic item	Explanation	Repair order Recheck SRS at each replacement
SIDE MODULE LH [OPEN] [B1134]	● Front LH side air bag module circuit is open.	<ol style="list-style-type: none"> 1. Visually check the wiring harness connection. 2. Replace the harness if it has visible damage. 3. Replace front LH seat back assembly (front LH side air bag module). (Before disposal, it must be deployed.) 4. Replace the air bag diagnosis sensor unit. 5. Replace the related harness.
SIDE MODULE LH [VB-SHORT] [B1135]	● Front LH side air bag module circuit is shorted to some power supply circuit.	
SIDE MODULE LH [GND-SHORT] [B1136]	● Front LH side air bag module circuit is shorted to ground.	
SIDE MODULE LH [SHORT] [B1137]	● Front LH side air bag module circuits are shorted to each other.	
SIDE MODULE RH [OPEN] [B1129]	● Front RH side air bag module circuit is open.	<ol style="list-style-type: none"> 1. Visually check the wiring harness connection. 2. Replace the harness if it has visible damage. 3. Replace front RH seat back assembly (front RH side air bag module). (Before disposal, it must be deployed.) 4. Replace the air bag diagnosis sensor unit. 5. Replace the related harness.
SIDE MODULE RH [VB-SHORT] [B1130]	● Front RH side air bag module circuit is shorted to some power supply circuit.	
SIDE MODULE RH [GND-SHORT] [B1131]	● Front RH side air bag module circuit is shorted to ground.	
SIDE MODULE RH [SHORT] [B1132]	● Front RH side air bag module circuits are shorted to each other.	
SATELLITE SENS LH [UNIT FAIL] [B1118] or [B1119] SATELLITE SENS LH [COMM FAIL] [B1120]	● LH side air bag (satellite) sensor	<ol style="list-style-type: none"> 1. Visually check the wiring harness connection. 2. Replace the harness if it has visible damage. 3. Replace the LH side air bag (satellite) sensor. 4. Replace the air bag diagnosis sensor unit. 5. Replace the related harness.
SATELLITE SENS RH [UNIT FAIL] [B1113] or [B1114] SATELLITE SENS RH [COMM FAIL] [B1115]	● RH side air bag (satellite) sensor	<ol style="list-style-type: none"> 1. Visually check the wiring harness connection. 2. Replace the harness if it has visible damage. 3. Replace the RH side air bag (satellite) sensor. 4. Replace the air bag diagnosis sensor unit. 5. Replace the related harness.
PRE-TEN FRONT LH [OPEN] [B1086]	● The circuit for front LH seat belt pre-tensioner is open.	<ol style="list-style-type: none"> 1. Visually check the wiring harness connections. 2. Replace the harness if it has visible damage. 3. Replace front LH seat belt pre-tensioner. (Before disposal, it must be deployed.) 4. Replace the air bag diagnosis sensor unit. 5. Replace the related harness.
PRE-TEN FRONT LH [VB-SHORT] [B1087]	● The circuit for front LH seat belt pre-tensioner is shorted to some power supply circuit.	
PRE-TEN FRONT LH [GND-SHORT] [B1088]	● The circuit for front LH seat belt pre-tensioner is shorted to ground.	
PRE-TEN FRONT LH [SHORT] [B1089]	● The circuits for the front LH seat belt pre-tensioner are shorted to each other.	

TROUBLE DIAGNOSIS

Diagnostic item	Explanation	Repair order Recheck SRS at each replacement	
PRE-TEN FRONT RH [OPEN] [B1081]	● The circuit for front RH seat belt pre-tensioner is open.	1. Visually check the wiring harness connections.	A
PRE-TEN FRONT RH [VB-SHORT] [B1082]	● The circuit for front RH seat belt pre-tensioner is shorted to some power supply circuit.	2. Replace the harness if it has visible damage.	B
PRE-TEN FRONT RH [GND-SHORT] [B1083]	● The circuit for front RH seat belt pre-tensioner is shorted to ground.	3. Replace front RH seat belt pre-tensioner. (Before disposal, it must be deployed.)	C
PRE-TEN FRONT RH [SHORT] [B1084]	● The circuits for the front RH seat belt pre-tensioner are shorted to each other.	4. Replace the air bag diagnosis sensor unit.	D
CURTAIN MODULE LH [OPEN] [B1150]	● The LH side curtain air bag module circuit is open.	5. Replace the related harness.	E
CURTAIN MODULE LH [VB-SHORT] [B1151]	● The LH side curtain air bag module circuit is shorted to some power supply circuits.	1. Visually check the wiring harness connection.	F
CURTAIN MODULE LH [GND-SHORT] [B1152]	● The LH side curtain air bag module circuit is shorted to ground.	2. Replace the harness if it has visible damage.	G
CURTAIN MODULE LH [SHORT] [B1153]	● The circuits for the LH side curtain air bag module are shorted to each other.	3. Replace LH side curtain air bag module. (Before disposal, it must be deployed.)	
CURTAIN MODULE RH [OPEN] [B1145]	● The RH side curtain air bag module circuit is open.	4. Replace the air bag diagnosis sensor unit.	
CURTAIN MODULE RH [VB-SHORT] [B1146]	● The RH side curtain air bag module circuit is shorted to some power supply circuits.	5. Replace the related harness.	
CURTAIN MODULE RH [GND-SHORT] [B1147]	● The RH side curtain air bag module circuit is shorted to ground.	1. Visually check the wiring harness connection.	I
CURTAIN MODULE RH [SHORT] [B1148]	● The circuits for the RH side curtain air bag module are shorted to each other.	2. Replace the harness if it has visible damage.	J
CONTROL UNIT [B1XXX]	● Air bag diagnosis sensor unit is malfunctioning.	3. Replace RH side curtain air bag module. (Before disposal, it must be deployed.)	K
OCCUPANT SENS C/U [UNIT FAIL] [B1017], [B1020] or [B1021]	● Occupant classification system is malfunctioning.	4. Replace the air bag diagnosis sensor unit.	L
OCCUPANT SENS C/U [COMM FAIL] [B1022]	● Communication between the occupant classification system control unit and air bag diagnosis sensor unit is interrupted.	5. Replace the related harness.	M
OCCUPANT SENS [UNIT FAIL] [B1018]	● Occupant classification sensor is malfunctioning.	1. Visually check the wiring harness connection.	
		2. Replace the diagnosis sensor unit.	
		1. Replace RH front seat cushion/occupant classification system control unit assembly.	
		2. Replace the harness if it has visible damage.	
		3. Replace RH front seat cushion/occupant classification system control unit assembly.	
		4. Replace the air bag diagnosis sensor unit.	
		5. Replace the related harness.	

SRS

TROUBLE DIAGNOSIS

Diagnostic item	Explanation	Repair order Recheck SRS at each replacement
BELT TENSION SENS [UNIT FAIL] [B1019]	<ul style="list-style-type: none"> ● Belt tension sensor is malfunctioning. 	<ol style="list-style-type: none"> 1. Visually check the wiring harness connection. 2. Replace the harness if it has visible damage. 3. Replace RH front seat belt assembly. 4. Replace RH front seat cushion/ occupant classification system control unit assembly.
PASS A/B INDCTR CKT [B1023]	<ul style="list-style-type: none"> ● Front passenger air bag off indicator is malfunctioning. 	<ol style="list-style-type: none"> 1. Visually check the wiring harness connection. 2. Replace the harness if it has visible damage. 3. Replace front passenger air bag off indicator. 4. Replace the air bag diagnosis sensor unit. 5. Replace the related harness.

TROUBLE DIAGNOSIS

Trouble Diagnosis Without CONSULT-II

EHS0014C

DIAGNOSTIC PROCEDURE 6

Inspect SRS Malfunction Using "AIR BAG" Warning Lamp—Diagnosis Mode

NOTE:

SRS will not enter Diagnosis mode if no malfunction is detected in User mode.

1. Turn ignition switch ON.
2. After "AIR BAG" warning lamp lights for 7 seconds, turn ignition switch OFF within 1 second.
3. Wait more than 3 seconds.
4. Repeat steps 1 to 3 two more times (3 times total).
5. Turn ignition switch ON.

SRS is now in Diagnosis mode.

"AIR BAG" warning lamp operates in Diagnosis mode as follows:

A

B

C

D

E

F

G

SRS

I

J

K

L

M

TROUBLE DIAGNOSIS

WARNING LAMP FLASH CODE CHART

<Diagnosis results (previously stored in the memory) might not be erased after repair or intermittent malfunctions have been detected in the past.>

Flash pattern	Repair order
<p>a through b are repeated.</p>	<p>1. Go to DIAGNOSTIC PROCEDURES 2 and 3.</p>

SHIA0026E

<Driver air bag module>	
Flash pattern	Repair order
<p>a through d are repeated. d: Two flashes indicate malfunctioning driver air bag module circuits.</p>	<ol style="list-style-type: none"> 1. Visually check the wiring harness connection. 2. Replace the harness if it has visible damage. 3. Replace the spiral cable. 4. Replace driver air bag module. (Before disposal, it must be deployed.) 5. Replace the air bag diagnosis sensor unit. 6. Replace the related harness.

WHIA0197E

<Air bag diagnosis sensor unit>	
Flash pattern	Repair order
<p>a through d are repeated. d: Seven flashes indicate malfunctioning diagnosis sensor unit circuit.</p>	<ol style="list-style-type: none"> 1. Visually check the wiring harness connections. 2. Replace the harness if it has visible damage. 3. Replace the air bag diagnosis sensor unit. 4. Replace the related harness.

WHIA0198E

<Front passenger air bag module>	
Flash pattern	Repair order
<p>a through d are repeated. d: Eight flashes indicate malfunctioning front passenger air bag module circuit.</p>	<ol style="list-style-type: none"> 1. Visually check the wiring harness connection. 2. Replace the harness if it has visible damage. 3. Replace front passenger air bag module. (Before disposal, it must be deployed.) 4. Replace the airbag diagnosis sensor unit. 5. Replace the related harness.

WHIA0199E

TROUBLE DIAGNOSIS

<Crash zone sensor>	
Flash pattern	Repair order
<p>a through d are repeated. d: Six flashes indicate malfunctioning crash zone sensor circuit.</p>	<ol style="list-style-type: none"> 1. Visually check the wiring harness connection. 2. Replace the harness if it has visible damage. 3. Replace the crash zone sensor. 4. Replace the air bag diagnosis sensor unit. 5. Replace the related harness.

WHIA0200E

<Front RH seat belt pre-tensioner>	
Flash pattern	Repair order
<p>a through d are repeated. d: One flash indicates malfunctioning front RH seat belt pre-tensioner circuit.</p>	<ol style="list-style-type: none"> 1. Visually check the wiring harness connections. 2. Replace the harness if it has visible damage. 3. Replace front RH seat belt pre-tensioner. (Before disposal, it must be activated.) 4. Replace the air bag diagnosis sensor unit. 5. Replace the related harness.

WHIA0201E

<Front LH seat belt pre-tensioner>	
Flash pattern	Repair order
<p>a through d are repeated. d: Three flashes indicate malfunctioning front LH seat belt pre-tensioner circuit.</p>	<ol style="list-style-type: none"> 1. Visually check the wiring harness connections. 2. Replace the harness if it has visible damage. 3. Replace front LH seat belt pre-tensioner. (Before disposal, it must be activated.) 4. Replace the air bag diagnosis sensor unit. 5. Replace the related harness.

WHIA0202E

<RH side air bag (Satellite) sensor>	
Flash pattern	Repair order
<p>a through f are repeated. f: Three flashes indicate malfunctioning RH side air bag (Satellite) sensor circuit.</p>	<ol style="list-style-type: none"> 1. Visually check the wiring harness connection. 2. Replace the harness if it has visible damage. 3. Replace the RH side air bag (Satellite) sensor. 4. Replace the air bag diagnosis sensor unit. 5. Replace the related harness.

WHIA0203E

TROUBLE DIAGNOSIS

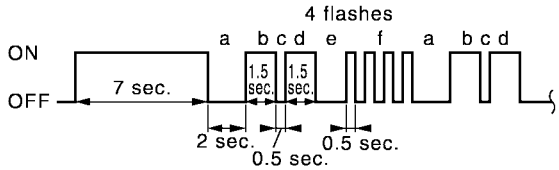
<LH side air bag (Satellite) sensor>	
Flash pattern	Repair order
<p>a through f are repeated. f: Four flashes indicate malfunctioning LH side air bag (Satellite) sensor.</p> 	<ol style="list-style-type: none"> 1. Visually check the wiring harness connection. 2. Replace the harness if it has visible damage. 3. Replace the LH side air bag (Satellite) sensor. 4. Replace the air bag diagnosis sensor unit. 5. Replace the related harness.

WHIA0204E

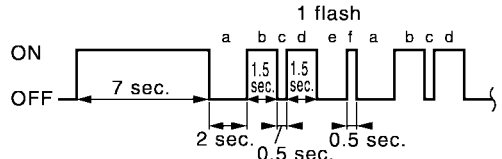
<Front RH side air bag module>	
Flash pattern	Repair order
<p>a through f are repeated. f: One flash indicate malfunctioning front RH side air bag module circuit.</p> 	<ol style="list-style-type: none"> 1. Visually check the wiring harness connection. 2. Replace the harness if it has visible damage. 3. Replace front RH seat back assembly. (Before disposal, side air bag module must be deployed.) 4. Replace the air bag diagnosis sensor unit. 5. Replace the related harness.

WHIA0205E

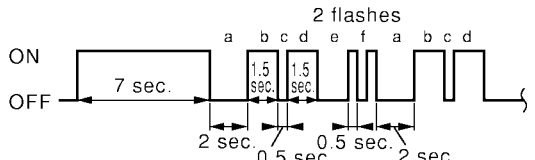
<Front LH side air bag module>	
Flash pattern	Repair order
<p>a through f are repeated. f: Two flashes indicate malfunctioning front LH side air bag module circuit.</p> 	<ol style="list-style-type: none"> 1. Visually check the wiring harness connection. 2. Replace the harness if it has visible damage. 3. Replace front LH seat back assembly. (Before disposal, side air bag module must be deployed.) 4. Replace the air bag diagnosis sensor unit. 5. Replace the related harness.

WHIA0206E

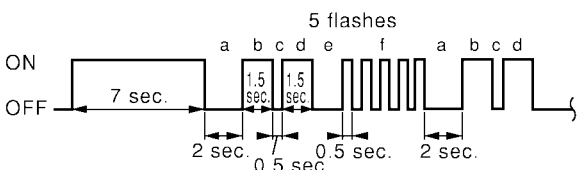
<RH side front curtain air bag module>	
Flash pattern	Repair order
<p>a through f are repeated. f: Five flashes indicate malfunctioning RH side front curtain air bag module circuit.</p> 	<ol style="list-style-type: none"> 1. Visually check the wiring harness connection. 2. Replace the harness if it has visible damage. 3. Replace RH side front curtain air bag module. (Before disposal, it must be deployed.) 4. Replace the air bag diagnosis sensor unit. 5. Replace the related harness.

WHIA0222E

TROUBLE DIAGNOSIS

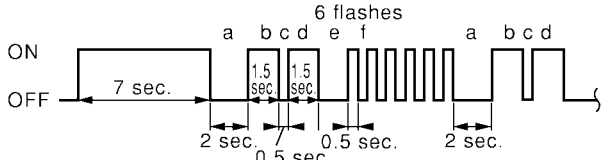
<LH side front curtain air bag module>	
Flash pattern	Repair order
<p>a through f are repeated. f: Six flashes indicate malfunctioning LH side front curtain air bag module circuit.</p> 	<ol style="list-style-type: none"> 1. Visually check the wiring harness connection. 2. Replace the harness if it has visible damage. 3. Replace LH side front curtain air bag module. (Before disposal, it must be deployed.) 4. Replace the air bag diagnosis sensor unit. 5. Replace the related harness.

WHIA0223E

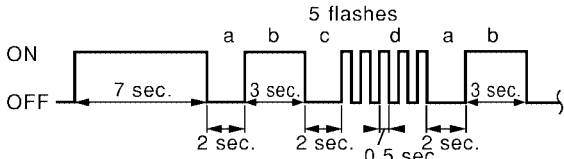
<Occupant classification system>	
Flash pattern	Repair order
<p>a through d are repeated. d: Five flashes indicate malfunctioning occupant classification system control unit.</p> 	<ol style="list-style-type: none"> 1. Visually check the wiring harness connection. 2. Replace the harness if it has visible damage. 3. Replace the RH front seat cushion occupant classification system control unit assembly. 4. Replace the air bag diagnosis sensor unit.

WHIA0211E

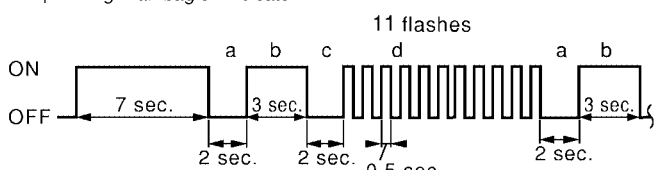
<Front passenger air bag off indicator>	
Flash pattern	Repair order
<p>a through d are repeated. d: Eleven flashes indicate malfunctioning front passenger air bag off indicator.</p> 	<ol style="list-style-type: none"> 1. Visually check the wiring harness connection. 2. Replace the harness if it has visible damage. 3. Replace front passenger air bag off indicator. 4. Replace the air bag diagnosis sensor unit. 5. Replace the related harness.

WHIA0212E

A
B
C
D
E
F
G
SRS
I
J
K
L
M

TROUBLE DIAGNOSIS

Trouble Diagnosis: "AIR BAG" Warning Lamp Does Not Turn Off DIAGNOSTIC PROCEDURE 6

EHS0014D

1. CHECK CONDITION OF AIR BAG MODULE

Inspect for any deployed air bag modules or seat belt pre-tensioners.

Are any air bag modules or seat belt pre-tensioners deployed?

- YES >> Refer to [SRS-67, "COLLISION DIAGNOSIS"](#).
- NO >> GO TO 2.

2. CHECK THE AIR BAG FUSE

Check 10A fuse [No. 13, located in the fuse block (J/B)].
Refer to [PG-4, "POWER SUPPLY ROUTING CIRCUIT"](#).

OK or NG

- OK >> GO TO 4.
- NG >> GO TO 3.

3. CHECK AIR BAG FUSE AGAIN

Replace 10A fuse [No. 13, located in the fuse block (J/B)] and turn ignition switch ON.

Does the fuse blow again?

- YES >> Repair main harness.
- NO >> Inspection End.

4. CHECK AIR BAG DIAGNOSIS SENSOR UNIT



Connect CONSULT-II and CONSULT-II CONVERTER and touch "START".

Is "AIR BAG" displayed on CONSULT-II?

- YES >> GO TO 5.
- NO >> Visually inspect the air bag diagnosis sensor unit harness connections. If the connections are OK, replace the air bag diagnosis sensor unit. Refer to [SRS-58, "Removal and Installation"](#).

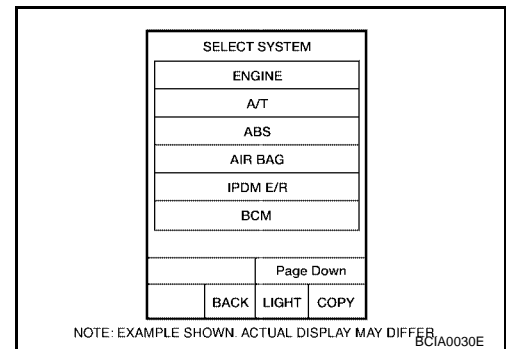

5. CHECK HARNESS CONNECTION

Check for loose connections between the combination meter and the air bag diagnosis sensor unit.

OK or NG

- OK >> Replace air bag diagnosis sensor unit. Refer to [SRS-58, "Removal and Installation"](#).
- NG >> Properly connect the combination meter and air bag diagnosis sensor unit harness connectors. If "AIR BAG" warning lamp still does not turn off, replace the wiring harness.

TROUBLE DIAGNOSIS

Trouble Diagnosis: "AIR BAG" Warning Lamp Does Not Turn On DIAGNOSTIC PROCEDURE 7

EHS0014E

1. CHECK METER FUSE

Check the 10A fuse [No. 14, located in the fuse block (J/B)].
Refer to [PG-4, "POWER SUPPLY ROUTING CIRCUIT"](#).

OK or NG

OK >> GO TO 3.
NG >> GO TO 2.

2. CHECK METER FUSE AGAIN

Replace 10A fuse [No. 14, located in the fuse block (J/B)] and turn ignition switch ON.

Does the fuse blow again?

YES >> Repair the related harness.
NO >> Inspection End.

3. CHECK HARNESS CONNECTION BETWEEN AIR BAG DIAGNOSIS SENSOR UNIT AND COMBINATION METER

Disconnect the air bag diagnosis sensor unit harness connectors and turn ignition switch ON.

Does "AIR BAG" warning lamp turn on?

YES >> Replace the air bag diagnosis sensor unit. Refer to [SRS-58, "Removal and Installation"](#).
NO >> Check the combination meter power and ground circuits. If OK, replace combination meter.
Refer to [DI-25, "Removal and Installation of Combination Meter"](#).

A

B

C

D

E

F

G

SRS

I

J

K

L

M

DRIVER AIR BAG MODULE

PFP:K8510

DRIVER AIR BAG MODULE

Removal and Installation

EHS0014F

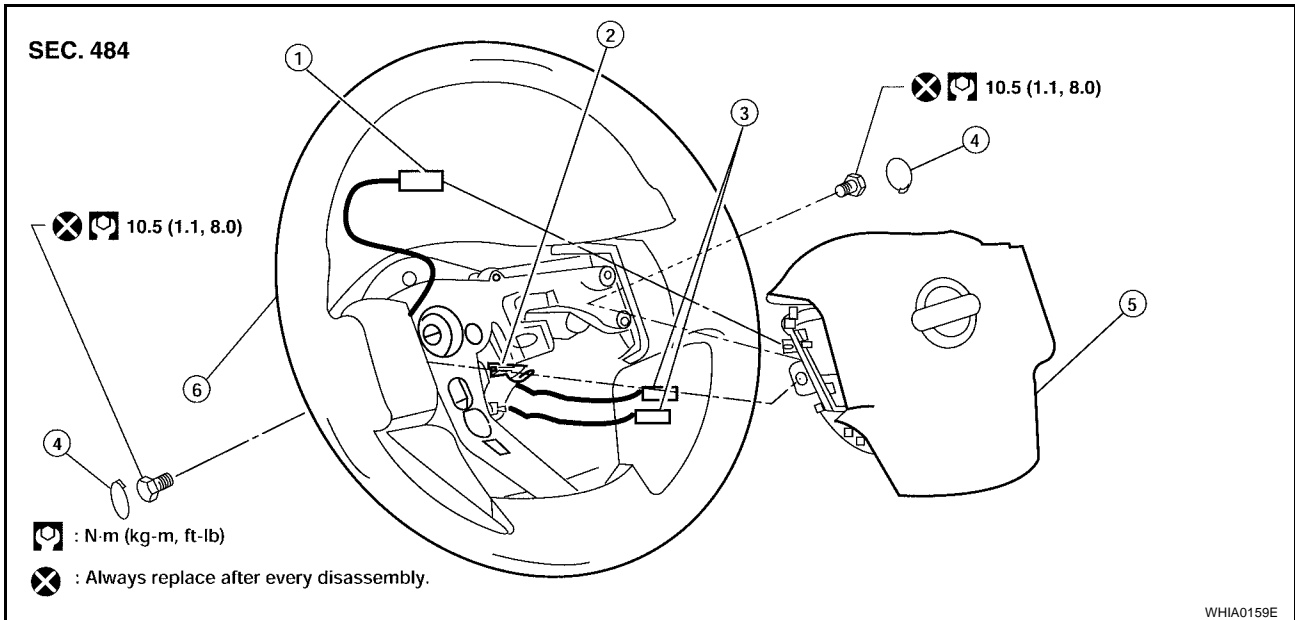

- | | | |
|--------------------|--------------------------|---------------------|
| 1. Horn harness | 2. Steering wheel hook | 3. Inflator harness |
| 4. Side lids RH/LH | 5. Driver air bag module | 6. Steering wheel |

REMOVAL

CAUTION:

- Do not attempt to repair or replace damaged direct-connect SRS component connectors. If a driver air bag direct-connect harness connector is damaged, the spiral cable must be replaced.
- Before servicing the SRS, turn ignition switch OFF, disconnect both battery cables and wait at least 3 minutes.
- When servicing the SRS, do not work from directly in front of air bag module.

1. Remove the left and right side bolts.
2. Lift the driver air bag module from the steering wheel.
3. Disconnect the air bag harness and horn connectors, then remove the driver air bag module.
 - For removal/installation of the direct-connect SRS connectors, refer to [SRS-8, "Direct-connect SRS Component Connectors"](#).

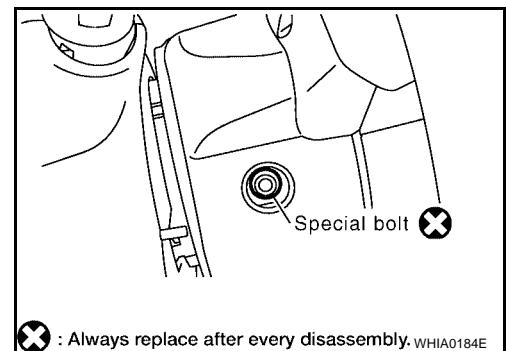

CAUTION:

- When servicing the SRS, do not work from directly in front of air bag module.
- Always place air bag module with pad side facing upward.
- Do not insert any foreign objects (screwdriver, etc.) into air bag module or harness connectors.
- Do not disassemble air bag module.
- Do not use old bolts after removal; replace with new bolts.
- Do not expose the air bag module to temperatures exceeding 90°C (194°F).

DRIVER AIR BAG MODULE

- Replace the air bag module if it has been dropped or sustained an impact.
- Do not allow oil, grease or water to come in contact with the air bag module.

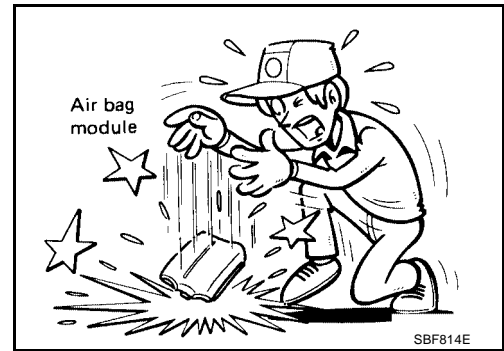

INSTALLATION

To install, reverse the removal procedure.

- If driver air bag module is being replaced due to deployment, spiral cable must also be replaced. Refer to [SRS-46, "SPIRAL CABLE"](#).
- For removal/installation of the direct-connect SRS connectors, refer to [SRS-8, "Direct-connect SRS Component Connectors"](#).
- After the work is completed, perform self-diagnosis to check that no malfunction is detected. Refer to [SRS-21, "SRS Operation Check"](#).

A

B

C

D

E

F

G

SRS

I

J

K

L

M

SPIRAL CABLE

PPF:25554

SPIRAL CABLE

Removal and Installation

EHS0014G

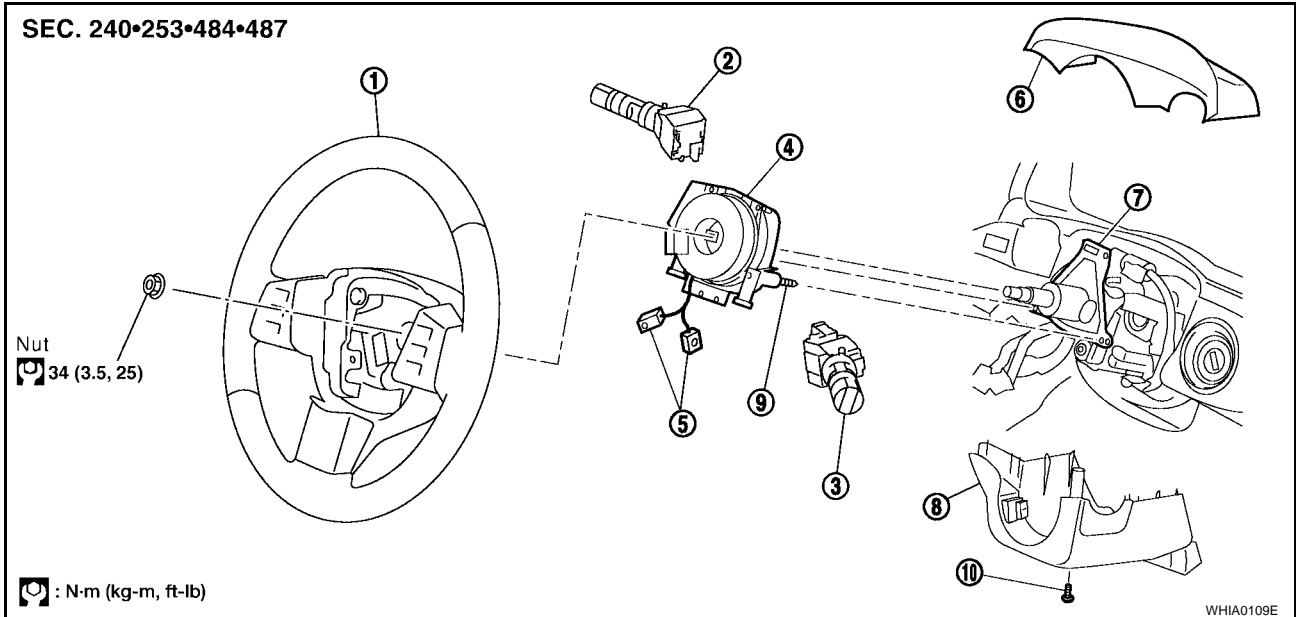

- | | | |
|--------------------|------------------------------------|----------------------------|
| 1. Steering wheel | 2. Lighting and turn signal switch | 3. Wiper and washer switch |
| 4. Spiral cable | 5. Driver air bag module connector | 6. Column cover upper |
| 7. Column assembly | 8. Column cover lower | 9. Screw (Do not remove) |
| 10. Screw | | |

REMOVAL

CAUTION:

- Before servicing the SRS, turn ignition switch OFF, disconnect both battery cables and wait at least 3 minutes.
 - When servicing the SRS, do not work from directly in front of air bag module.
1. Set the front wheels in the straight-ahead position.
 2. Remove driver air bag module. Refer to [SRS-44, "Removal and Installation"](#).
 3. Remove the steering wheel center nut.
 4. Disconnect the steering wheel switch/ horn connector from the spiral cable.
 5. Remove the steering wheel using Tool.

Tool number: A: J-1859A
B: J-42578

6. Remove the column cover upper and lower.

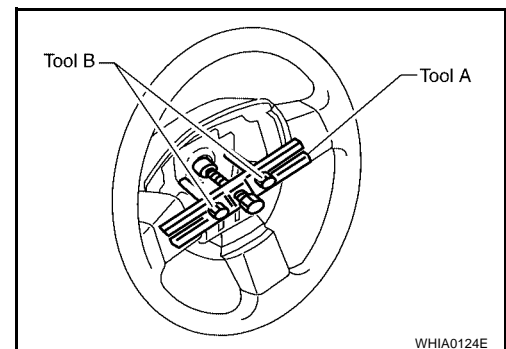

SPIRAL CABLE

7. Remove wiper washer switch connector, then pinch the tabs at wiper and washer switch base and slide switch away from steering column to remove.

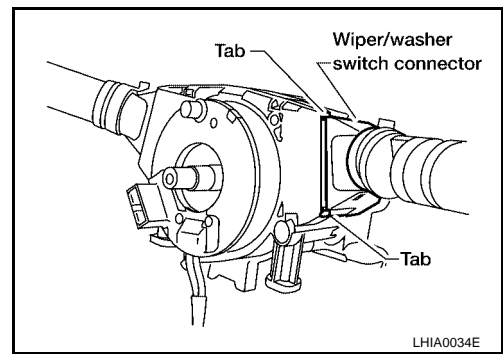

8. While pressing tabs, pull lighting and turn signal switch toward driver door and disconnect from base.

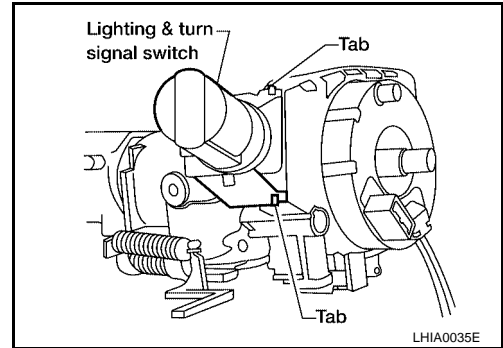

9. Remove the screws, release the clip, and remove the spiral cable.

CAUTION:

- Do not disassemble spiral cable.
- Do not apply lubricant to the spiral cable.

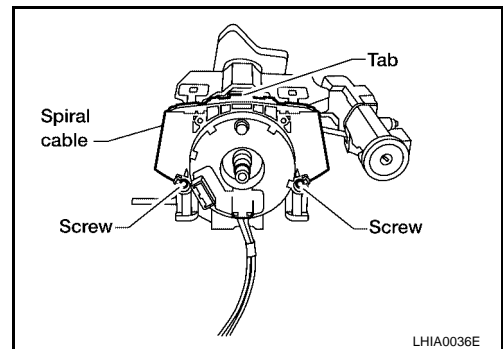

10. Remove the spiral cable connectors.

CAUTION:

With the steering linkage disconnected, the spiral cable may snap by turning the steering wheel beyond the limited number of turns. The spiral cable can be turned counterclockwise about 2.5 turns from the right end position.

INSTALLATION

Installation is in the reverse order of removal.

- Align spiral cable correctly when installing steering wheel. Make sure that the spiral cable is in the neutral position. The neutral position is detected by turning left 2.5 revolutions from the right end position and ending with the knob at the top.
- If equipped with VDC, refer to [BRC-148, "Adjustment of Steering Angle Sensor Neutral Position"](#) for steering angle sensor adjustment.
- After the work is completed, perform self-diagnosis to make sure no malfunction is detected. Refer to [SRS-21, "SRS Operation Check"](#).

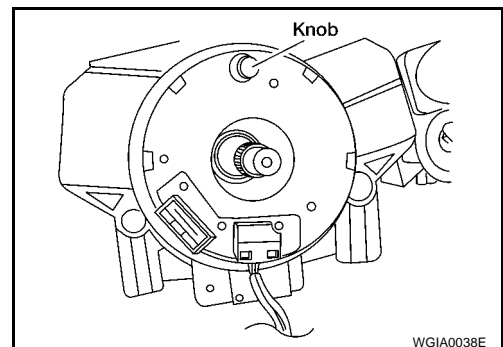

A
B
C
D
E
F
G
SRS
I
J
K
L
M

SPIRAL CABLE

CAUTION:

- The spiral cable may snap due to steering operation if the cable is not installed in the correct position.
- With the steering linkage disconnected, the cable may snap by turning the steering wheel beyond the limited number of turns. The spiral cable can be turned counterclockwise about 2.5 turns from the right end position.

Steering wheel center nut : 34 N·m (3.5 kg·m, 25 ft·lb)

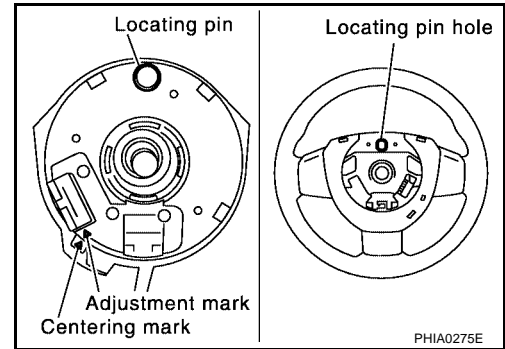

FRONT PASSENGER AIR BAG MODULE

PPF:K8515

FRONT PASSENGER AIR BAG MODULE

EHS0014H

Removal and Installation

The passenger air bag module originally installed in the vehicle uses direct-connect style harness connectors. Service replacement passenger air bag modules use tab-locking style harness connectors. If the passenger air bag module is replaced or if the direct-connect harness connectors are damaged, the vehicle wiring harness must be modified to allow connection of the service replacement passenger air bag module. Refer to [SRS-50, "WIRING HARNESS MODIFICATION"](#) for wiring harness modification procedure.

REMOVAL

CAUTION:

- Do not attempt to repair or replace damaged direct-connect front passenger air bag module connectors. If a direct-connect harness connector is damaged, the front passenger air bag must be replaced and the wiring harness modified.
 - Before servicing SRS, turn the ignition switch off, disconnect both battery cables and wait at least 3 minutes.
 - Always work from the side of or under front passenger air bag module.
1. Remove the glove box. Refer to [IP-14, "LOWER INSTRUMENT PANEL RH AND GLOVE BOX"](#).
 2. Remove 2 nuts (through glove box opening) retaining front passenger air bag module to instrument panel crossmember.
 3. Disconnect the air bag module electrical connectors.
 - For removal/installation of the direct-connect SRS connectors, refer to [SRS-8, "Direct-connect SRS Component Connectors"](#).
 4. Remove the instrument panel assembly from the vehicle. Refer to [IP-10, "INSTRUMENT PANEL"](#).
 5. Remove front passenger air bag module nuts and remove air bag module from the instrument panel assembly.

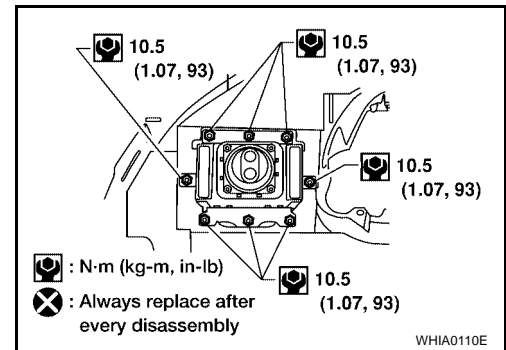

CAUTION:

- When servicing the SRS, do not work from directly in front of air bag module.
 - Always place front passenger air bag module with caution label side facing upward.
 - Do not insert any foreign objects (screwdriver, etc.) into air bag module or harness connectors.
 - Do not disassemble air bag module.
 - Do not use old nuts after removal; replace with new nuts.
 - Do not expose the front passenger air bag module to temperatures exceeding 90°C (194°F).
-
- Replace the air bag module if it has been dropped or sustained an impact.
 - Do not allow oil, grease or water to come in contact with the air bag module.
 - For removal/installation of the direct-connect SRS connectors, refer to [SRS-8, "Direct-connect SRS Component Connectors"](#).

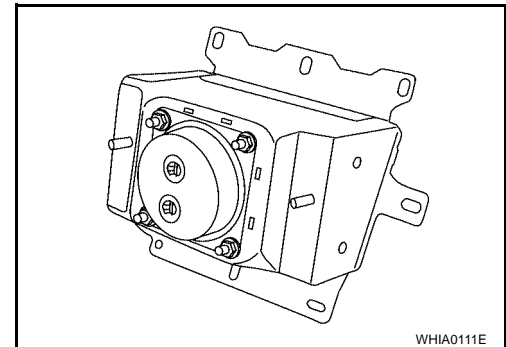

INSTALLATION

Original Passenger Air Bag Module

To install, reverse the removal procedure.

A
B
C
D
E
F
G
SRS
I
J
K
L
M

FRONT PASSENGER AIR BAG MODULE

- For removal/installation of the direct-connect SRS connectors, refer to [SRS-8, "Direct-connect SRS Component Connectors"](#) .

CAUTION:

- Always work from the side of or under front passenger air bag module.
- After the work is completed, perform self-diagnosis to check that no malfunction is detected. Refer to [SRS-21, "SRS Operation Check"](#) .

Service Replacement Passenger Air Bag Module

1. Install the front passenger air bag module to the instrument panel pad assembly.

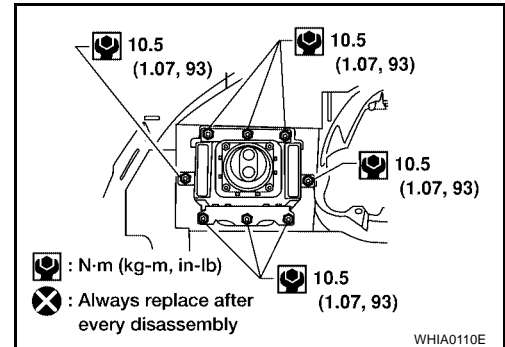

2. Install the instrument panel assembly. Refer to [IP-10, "INSTRUMENT PANEL"](#) .
3. Connect the front passenger air bag module harness connector to yellow 4-pin service replacement air bag connector and fasten connector to mounting bracket.

CAUTION:

- Always work from the side of or under front passenger air bag module.
- After the work is completed, perform self-diagnosis to check that no malfunction is detected. Refer to [SRS-21, "SRS Operation Check"](#) .

WIRING HARNESS MODIFICATION

The passenger air bag module originally installed in the vehicle uses direct-connect style harness connectors. Service replacement passenger air bag modules use tab-locking style harness connectors. If the passenger air bag module is replaced or if the direct-connect harness connectors are damaged, the vehicle wiring harness must be modified to allow connection of the service replacement passenger air bag module.

NOTE:

The wiring harness modification is to be performed only if the vehicle is equipped with the original passenger air bag which uses direct-connect harness connectors. If the passenger air bag is to be replaced in a vehicle that has already had the service replacement passenger air bag installed, the wiring harness modification is not required.

CAUTION:

- Do not attempt to repair or replace damaged direct-connect front passenger air bag module connectors. If a direct-connect harness connector is damaged, the front passenger air bag must be replaced and the wiring harness modified.
 - Before servicing SRS, turn the ignition switch off, disconnect both battery cables and wait at least 3 minutes.
 - Always work from the side of or under front passenger air bag module.
 - After the work is completed, perform self-diagnosis to check that no malfunction is detected. Refer to [SRS-21, "SRS Operation Check"](#) .
1. Locate the yellow and orange direct-connect passenger air bag module harness connectors.
 2. Use wire cutters to cut back both previously used direct-connect passenger air bag module harness connectors from the vehicle wiring harness approximately 50 mm (1.9 in) from the connectors.
 3. Remove approximately 150 mm (5.9 in) of the vehicle harness covering from the cut end.

FRONT PASSENGER AIR BAG MODULE

- Slide a piece of dual-wall heat shrink tubing (provided in the passenger air bag service kit) onto each wire of the previously used vehicle wiring harness.

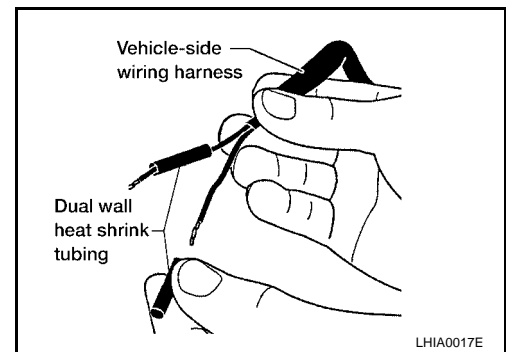

- Fold each wire back and insert into the end of the heat shrink tubing so that the end of the wire is approximately centered in the heat shrink tubing.

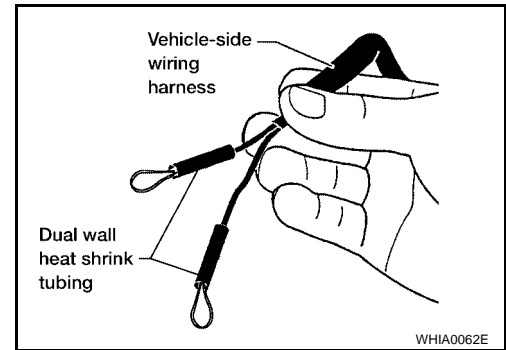

- Use a heat gun to shrink the heat shrink tubing and seal the wire.
- Use electrical tape to secure the modified circuits to the outside of the wiring harness.
- Locate the front passenger air bag service replacement connector that is taped back to the main harness. Unwrap the tape to access the yellow service replacement connector and remove the dust cover from the connector.

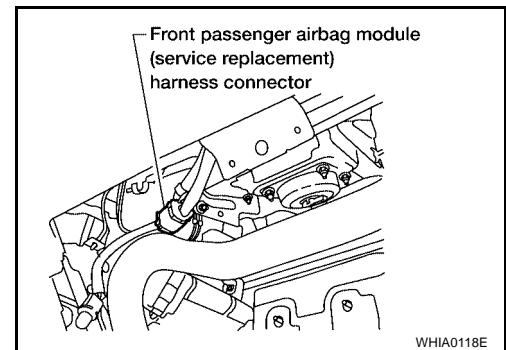

A

B

C

D

E

F

G

SRS

I

J

K

L

M

FRONT SIDE AIR BAG MODULE

PPF:K8EH0

EHS0014I

FRONT SIDE AIR BAG MODULE

Removal and Installation REMOVAL

WARNING:

Removal of front side air bag module should only be done to allow deployment of front side air bag module prior to disposal of seatback assembly.

Only complete seatback assemblies can be replaced. Refer to [SE-97, "Removal of seatback assembly"](#).

CAUTION:

- Before servicing the SRS, turn the ignition switch off, disconnect both battery cables and wait at least 3 minutes.
 - When servicing the SRS, do not work from directly in front of air bag module.
1. Remove the front seat. Refer to [SE-96, "REMOVAL"](#).
 2. Remove the seatback trim and pad. Refer to [SE-96, "SEATBACK TRIM AND PAD"](#).
 3. Remove the seatback rear finisher and remove the retainers securing the seat cushion trim. Refer to [SE-98, "SEAT CUSHION TRIM AND PAD"](#).
 4. Remove air bag module harness clips.
 5. Remove the fasteners from the front side air bag module and remove the front side air bag module.

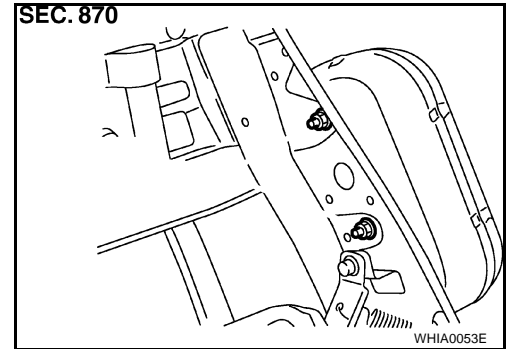

CAUTION:

- When using a clip removal tool to remove the seatback board, take care not to damage the harness for front side air bag module.
- When servicing the SRS, do not work from directly in front of air bag module.
- Always place the front side air bag module with the mounting stud side facing down.
- Do not insert any foreign objects (screwdrivers, etc.) into air bag module or harness connectors.
- Do not disassemble air bag module.
- Do not expose front seatback assembly (side air bag module) to temperatures exceeding 90°C (194°F).
- Replace front seatback assembly (side air bag module) if it has been dropped or sustained an impact.
- Do not allow oil, grease or water to come in contact with the air bag module.
- If front side air bag module is deployed, the front seatback assembly must be replaced.

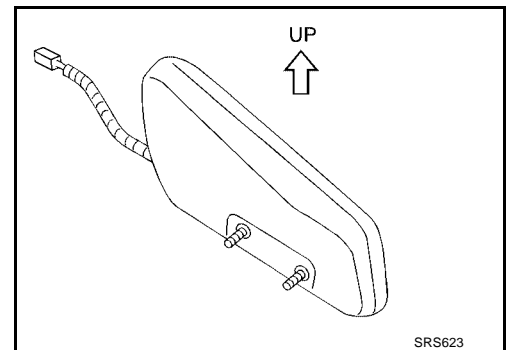

INSTALLATION

WARNING:

Removal of front side air bag module should only be done to allow deployment of front side air bag module prior to disposal of seatback assembly.

Only complete seatback assemblies can be replaced. Refer to [SE-97, "Removal of seatback assembly"](#).

SIDE CURTAIN AIR BAG MODULE

PFP:985P0

SIDE CURTAIN AIR BAG MODULE

Removal and Installation

EHS0014J

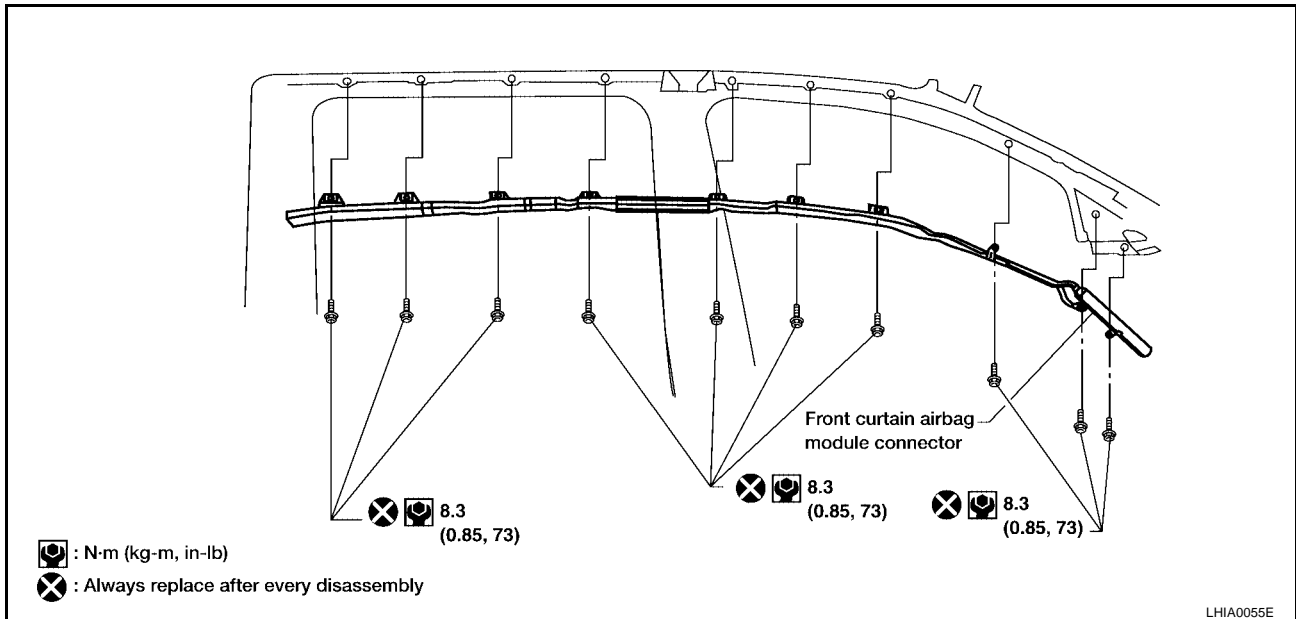

REMOVAL

CAUTION:

- Do not attempt to repair or replace damaged direct-connect SRS component connectors. If a direct-connect harness connector is damaged, the harness must be replaced.
 - Before servicing the SRS, turn the ignition switch off, disconnect both battery cables and wait at least 3 minutes.
 - When servicing the SRS, do not work from directly in front of air bag module.
1. Remove headlining. Refer to [EI-43, "Removal and Installation"](#).
 2. Disconnect front side curtain air bag module connectors.
 - For removal/installation of the direct-connect SRS connectors, refer to [SRS-8, "Direct-connect SRS Component Connectors"](#).
 3. Remove the bolts in order starting at the front or rear, and remove the side curtain air bag module.

CAUTION:

- When servicing the SRS, do not work from directly in front of air bag module.
- Do not insert any foreign objects (screwdriver, etc.) into air bag module or harness connectors.
- Do not disassemble air bag module.
- Do not expose the air bag module to temperatures exceeding 90°C (194°F).
- Replace side curtain air bag module if it has been dropped or sustained an impact.
- Do not allow oil, grease or water to come in contact with the air bag module.



INSTALLATION

To install, reverse the removal procedure.

- For removal/installation of the direct-connect SRS connectors, refer to [SRS-8, "Direct-connect SRS Component Connectors"](#).

A
B
C
D
E
F
G

SRS

I
J
K
L
M

SIDE CURTAIN AIR BAG MODULE

- After replacement of side curtain air bag module, perform self-diagnosis to check that no malfunction is detected. Refer to [SRS-21, "SRS Operation Check"](#).

CRASH ZONE SENSOR

PF9:98531

CRASH ZONE SENSOR

Removal and Installation REMOVAL

EHS0014K

CAUTION:

- Before servicing the SRS, turn the ignition switch off, disconnect both battery cables and wait at least 3 minutes.
1. Remove front grille. Refer to [EI-20, "Removal and Installation"](#).
 2. Disconnect the crash zone sensor harness connector.
 3. Remove crash zone sensor nuts.

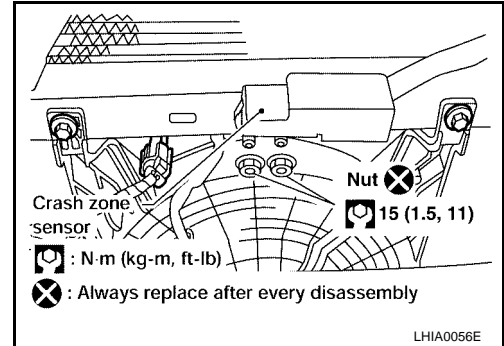

CAUTION:

- Replace crash zone sensor if it has been dropped or sustained an impact.
- Do not disassemble crash zone sensor.

INSTALLATION

To install, reverse the removal procedure.

- After the work is complete, perform self-diagnosis to check that no malfunction is detected. Refer to [SRS-21, "SRS Operation Check"](#).

A
B
C
D
E
F
G
I
J
K
L
M

SRS

SIDE AIR BAG (SATELLITE) SENSOR

PPF:98830

SIDE AIR BAG (SATELLITE) SENSOR

EHS0014L

Removal and Installation REMOVAL

CAUTION:

- Before servicing the SRS, turn the ignition switch off, disconnect both battery cables and wait at least 3 minutes.
- 1. Remove seat belt pre-tensioner. Refer to [SB-3, "Removal and Installation of Front Seat Belt"](#).
- 2. Remove side air bag (satellite) sensor nuts.
- 3. Disconnect the side air bag (satellite) sensor harness connector.

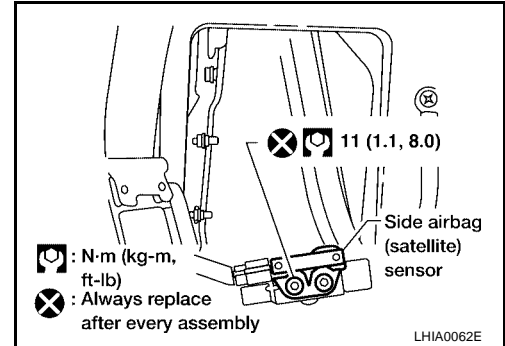

CAUTION:

- Do not use old nuts after removal; replace with new nuts.
- Check side air bag (satellite) sensor to ensure it is free of deformities, dents, cracks or rust. If it shows any visible signs of damage, replace it with new one.
- Do not disassemble side air bag (satellite) sensor.
- Replace side air bag (satellite) sensor if it has been dropped or sustained an impact.

INSTALLATION

To install, reverse the removal procedure.

- After the work is completed, perform self-diagnosis to check that no malfunction is detected. Refer to [SRS-21, "SRS Operation Check"](#).

FRONT SEAT BELT PRE-TENSIONER

FRONT SEAT BELT PRE-TENSIONER

PF:86884

Removal and Installation

EHS0014M

For removal and installation procedures, refer to [SB-3, "Removal and Installation of Front Seat Belt"](#) .

A

B

C

D

E

F

G

SRS

I

J

K

L

M

DIAGNOSIS SENSOR UNIT

PF2:28556

EHS0014N

DIAGNOSIS SENSOR UNIT

Removal and Installation REMOVAL

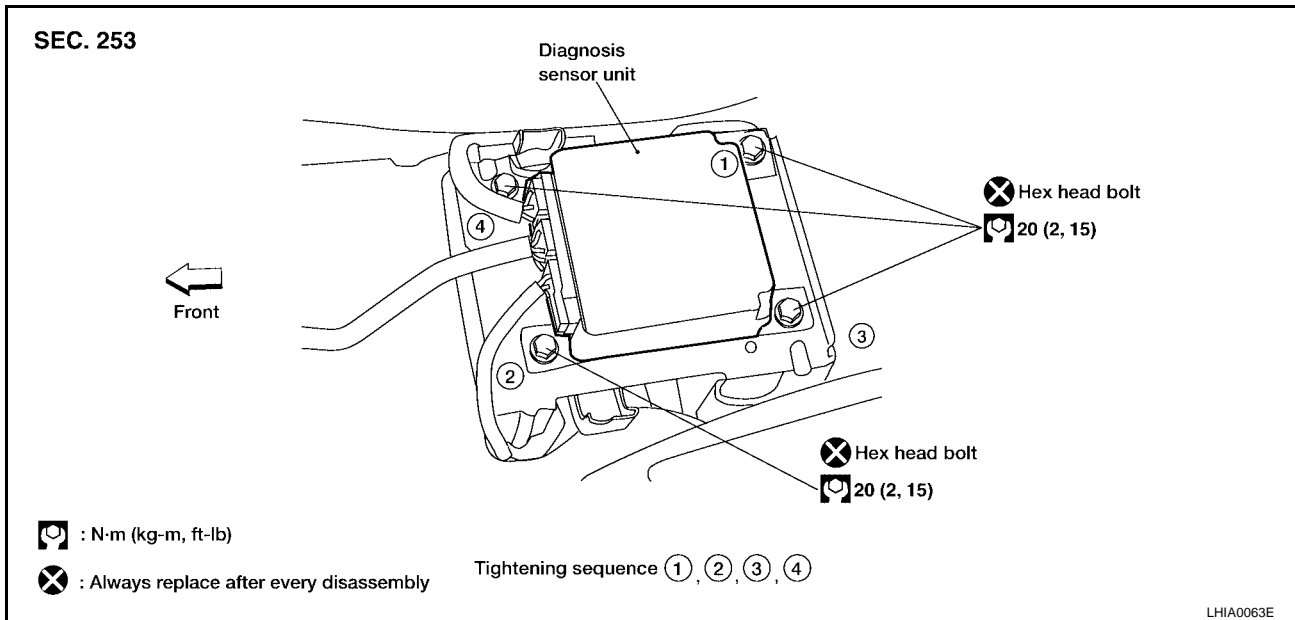

CAUTION:

- Before servicing the SRS, turn the ignition switch off, disconnect both battery cables and wait at least 3 minutes.
- 1. Disconnect the harness connectors for each air bag module and seat belt pre-tensioner.
- 2. Remove center console. Refer to [IP-15, "CENTER CONSOLE"](#).
- 3. Disconnect diagnosis sensor unit harness connectors.
- 4. Remove fixing bolts from the diagnosis sensor unit.

CAUTION:

- Do not use old bolts; replace with new bolts.
- Check diagnosis sensor unit bracket to ensure it is free of deformities, dents, cracks or rust. If it shows any visible signs of damage, replace with new one.
- Replace diagnosis sensor unit if it has been dropped or sustained an impact.

INSTALLATION

To install, reverse the removal procedure.

- After the work is completed, perform self-diagnosis to check that no malfunction is detected. Refer to [SRS-21, "SRS Operation Check"](#).

CAUTION:

- The diagnosis sensor unit must always be installed with the arrow mark "←" pointing toward the front of the vehicle for proper operation.

ECU DISCRIMINATED NO.

After replacing the diagnosis sensor unit, confirm that the diagnosis sensor unit identification is correct for the vehicle as equipped. Refer to [SRS-19, "CONSULT-II Function"](#).

OCCUPANT CLASSIFICATION SYSTEM CONTROL UNIT

OCCUPANT CLASSIFICATION SYSTEM CONTROL UNIT

PF9:98852

Removal and Installation

EHS00140

The occupant classification system control unit, occupant classification (pressure) sensor, and bladder are an integral part of the front passenger seat cushion and are replaced as an assembly. Refer to [SE-96, "REMOVAL"](#) to remove the seat, and [SE-98, "SEAT CUSHION TRIM AND PAD"](#) to replace the seat cushion.

A
B
C
D
E
F
G
I
J
K
L
M

SRS

DISPOSAL OF AIR BAG MODULE AND SEAT BELT PRE-TENSIONER

DISPOSAL OF AIR BAG MODULE AND SEAT BELT PRE-TENSIONER

PPF:00014

Caution for Air Bag Module and Seat Belt Pre-tensioner

EHS0014P

- Before disposing of air bag module, seat belt pre-tensioner or vehicle equipped with such systems, deploy the systems. If such systems have already been deployed due to an accident, dispose of them as indicated in "[SRS-66. "DISPOSING OF AIR BAG MODULE AND SEAT BELT PRE-TENSIONER"](#)".
- When deploying the air bag module or seat belt pre-tensioner, always use the Special Service Tool Deployment tool [KV99106400 (J-38381)].
- When deploying the air bag module or seat belt pre-tensioner, stand at least 5 m (16 ft) away from the component being deployed.
- When deploying air bag module or seat belt pre-tensioner, a fairly loud noise is made, followed by smoke being released. The smoke is not poisonous, however, be careful not to inhale smoke since it irritates the throat and can cause choking.
- Only deploy one air bag module or seat belt pre-tensioner at a time.
- Due to heat, leave deployed air bag module unattended for at least 30 minutes after deployment. Leave deployed seat belt pre-tensioner unattended for at least 10 minutes after deployment.
- Be sure to wear gloves when handling a deployed air bag module or seat belt pre-tensioner.
- Never apply water to the deployed air bag module or seat belt pre-tensioner.
- Wash your hands thoroughly after finishing work.
- Place the vehicle outdoors with an open space of at least 6 m (20 ft) on all sides when deploying air bag module or seat belt pre-tensioner while mounted in vehicle.
- Use a voltmeter to make sure the vehicle battery is fully charged.
- Do not dispose of the air bag module or seat belt pre-tensioner undeployed.

CHECKING DEPLOYMENT TOOL

Connecting to Battery

CAUTION:

The battery must show voltage of 9.6V or more.

Remove the battery from the vehicle and place it on dry wood blocks approximately 5 m (16 ft) away from the vehicle.

- Wait 3 minutes after the vehicle battery is disconnected before proceeding.
- Connect red clip of deployment tool to battery positive terminal and black clip to negative terminal.

Make sure the polarity is correct. The right side lamp in the tool marked "deployment tool power" should glow with a green light. If the right side lamp glows red, reverse the connections to the battery.

Deployment Tool Check

Place the deployment tool switch to the ON position. The left side lamp in the tool, marked "air bag connector voltage" should illuminate. If it does not illuminate, replace the tool.

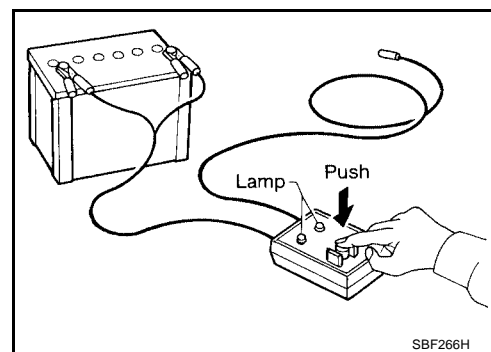
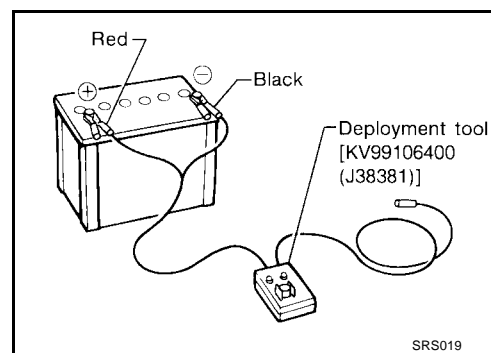

DISPOSAL OF AIR BAG MODULE AND SEAT BELT PRE-TENSIONER

Air Bag Deployment Tool Lamp Illumination Chart (Battery connected)

Switch operation	Left side lamp, green* "AIR BAG CONNECTOR VOLTAGE"	Right side lamp, green* "DEPLOYMENT TOOL POWER"
OFF	OFF	ON
ON	ON	ON

*: If this lamp glows red, the tool is connected to the battery incorrectly. Reverse the connections and make sure the lamp glows green.

DEPLOYMENT PROCEDURES FOR AIR BAG MODULE (OUTSIDE OF VEHICLE)

Unless the vehicle is being scrapped, deploying the air bag in the vehicle is not recommended. This may cause damage to the vehicle interior.

Anchor the deployment Tool in a vise secured to a firm foundation during deployment.

Tool number: KV99105300 (J-41246)

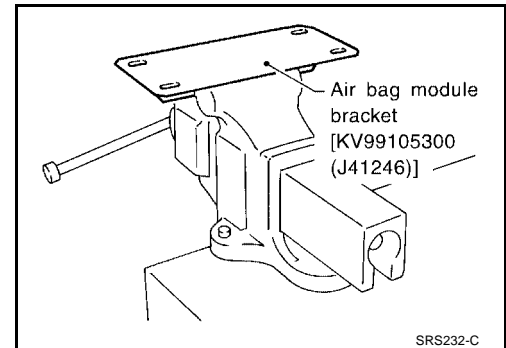

Deployment of Driver Air Bag Module (Outside of vehicle)

- Using wire, secure air bag module to the Tool at two places.

Tool number: KV99105300 (J-41246)

CAUTION:

Use wire of at least 1 mm (0.04 in) diameter.

- Firmly secure Tool with air bag module attached, in a vise.

Tool number: KV99105300 (J-41246)

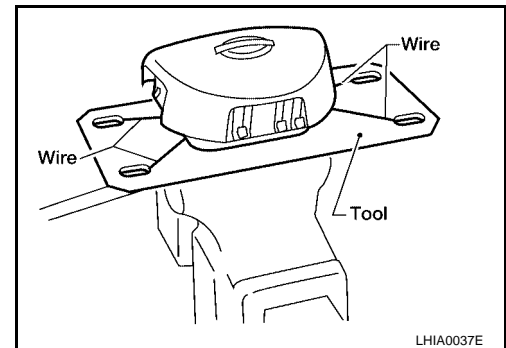

- Connect deployment Tool A to air bag module connector using Tool B.

Tool number: A: KV99106400 (J-38381)

B: KV99105300 (J-38381-80)

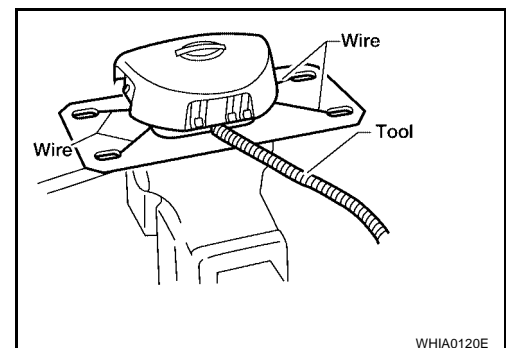

- Connect red clip of Tool to battery positive terminal and black clip to negative terminal.

Tool number: KV99106400 (J-38381)

- The lamp on the right side of the tool, marked "deployment tool power", should glow green, not red.
- Press the button on the deployment tool. The left side lamp on the tool, marked "air bag connector voltage", will illuminate and the air bag module will deploy.

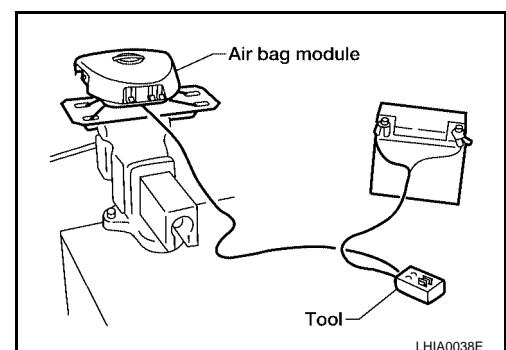

DISPOSAL OF AIR BAG MODULE AND SEAT BELT PRE-TENSIONER

CAUTION:

When deploying the driver air bag module, stand at least 5 m (16 ft) away from the air bag module.

Deployment of Front Passenger Air Bag Module (Outside of vehicle)

1. Firmly secure the Tool A in a vise, then secure Tool B to Tool A.

Tool number: A: KV99105300 (J-41246)

B: J-39401-100

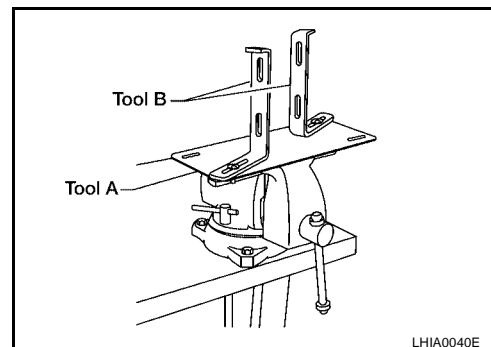

2. Match the two holes in the Tool and front passenger air bag module and fix them with two bolts.

Tool number: J-39401-100

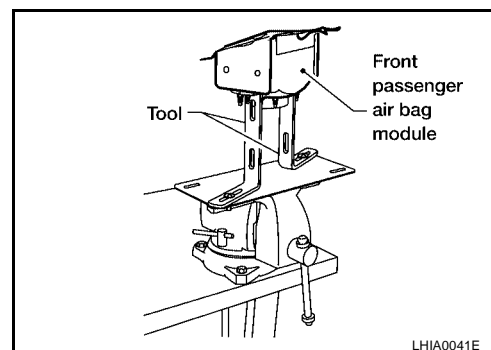

3. Connect deployment Tool A to front passenger air bag module using Tool B.

Tool number: A: KV99106400 (J-38381)

B: KV99105300 (J-38381-80)

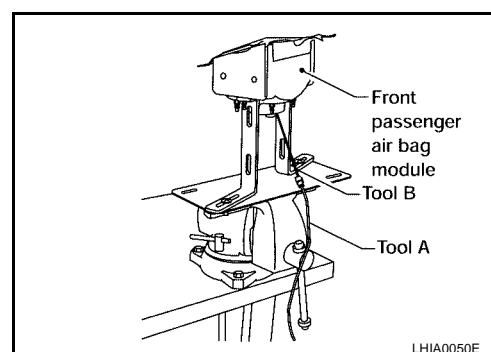

4. Connect red clip of the Tool to battery positive terminal and black clip to negative terminal.

Tool number: KV99106400 (J-38381)

5. The lamp on the right side of the Tool, marked "deployment tool power", should glow green, not red.

6. Press the button on the Tool. The left side lamp on the tool, marked "air bag connector voltage", will illuminate and the air bag module will deploy.

CAUTION:

- When deploying the front passenger air bag module, do not stand on the deploying side.
- Stand at least 5 m (16 ft) away from the air bag module.

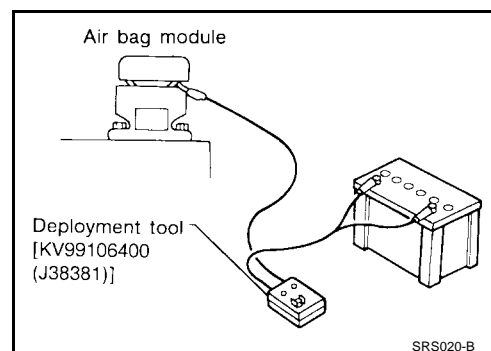

DISPOSAL OF AIR BAG MODULE AND SEAT BELT PRE-TENSIONER

Deployment of Front Side Air Bag Module (Outside of vehicle)

1. Make 6.5 mm (0.256 in) diameter holes in air bag module bracket [SST: KV99105300 (J-41246)] at the positions shown.

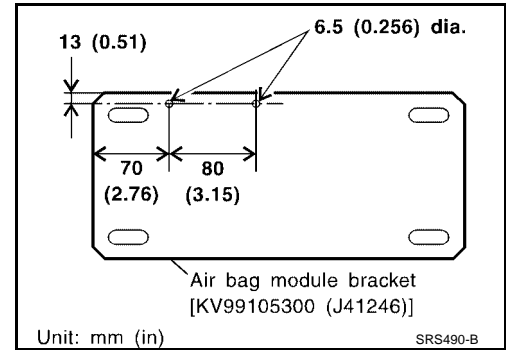

2. Firmly secure air bag module bracket [SST: KV99105300 (J-41246)] in a vise.
3. Insert the stud bolts of side air bag module into the two holes in air bag module bracket (held in vise) and fix them with two M6 nuts.

CAUTION:

Side air bag module should be secured to air bag module bracket [SST: KV99105300 (J41246)] in a vise with stud bolt side facing down.

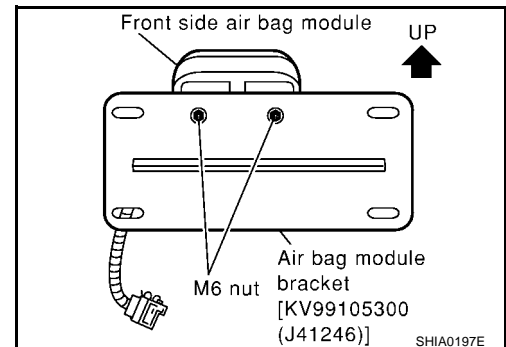

4. Connect deployment tool [SST: KV99106400 (J-38381)] connector to connector on air bag module using deployment tool adapter [SST: KV99109000 (J-44230)].

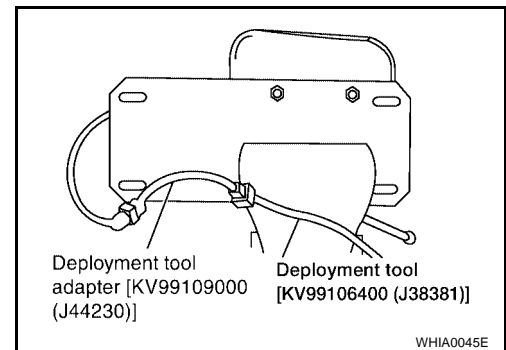

5. Connect red clip of deployment tool to battery positive terminal and black clip to negative terminal.
6. The lamp on the right side of the tool, marked “deployment tool power”, should glow green, not red.
7. Press the button on the deployment tool. The left side lamp on the tool, marked “air bag connector voltage”, will illuminate and the air bag module will deploy.

CAUTION:

When deploying the front side air bag module, stand at least 5 m (16 ft) away from the air bag module.

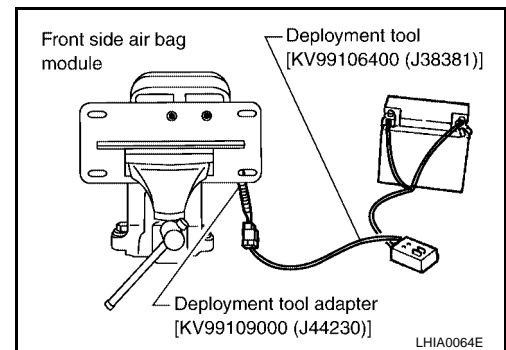

Deployment of Side Curtain Air Bag Module (Outside of vehicle)

NOTE:

The side curtain air bag module has a front and rear inflator that are connected by the fabric of the side curtain air bag. Follow the procedure to cut the fabric from the inflators, and then follow the procedure to deploy each inflator.

A
B
C
D
E
F
G
SRS
I
J
K
L
M

DISPOSAL OF AIR BAG MODULE AND SEAT BELT PRE-TENSIONER

1. Cut the inflator from side curtain air bag module.

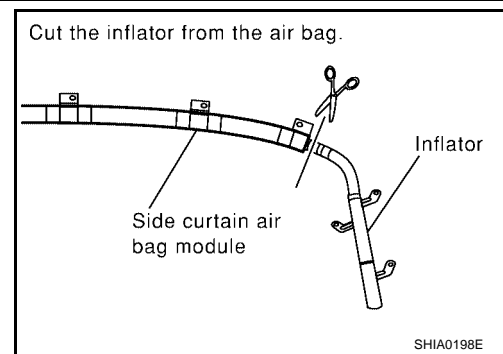

2. Connect deployment tool [SST: KV99106400 (J-38381)] to the inflator using deployment tool adapter (J-38381-80).

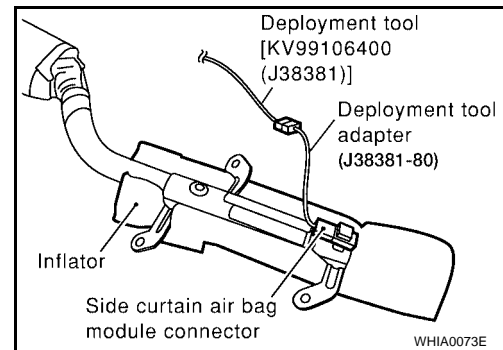

3. Put the inflator connected with the deployment tool [SST: KV99106400 (J-38381)] into a tire without a wheel.

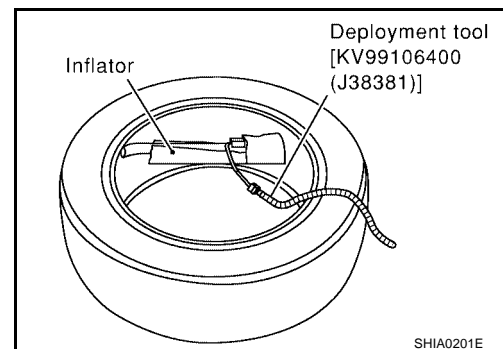

4. Put the tire with the inflator onto another tire without a wheel. Add an additional tire without a wheel and then a tire mounted on a wheel on top.

CAUTION:

Tie all tires together with a strap in order to keep them standing.

5. Connect red clip of deployment tool to battery positive terminal and black clip to negative terminal.
6. The lamp on the right side of the tool, marked "deployment tool power", should glow green, not red.
7. Press the button on the deployment tool. The left side lamp on the tool, marked "air bag connector voltage", will illuminate and the air bag module will deploy.

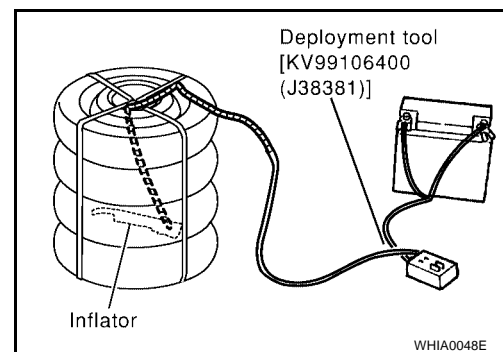

CAUTION:

When deploying the side curtain air bag module, stand at least 5 m (16 ft) away from the side curtain air bag module.

8. Repeat this procedure to deploy the second inflator.

DISPOSAL OF AIR BAG MODULE AND SEAT BELT PRE-TENSIONER

DEPLOYMENT PROCEDURES FOR SEAT BELT PRE-TENSIONER (OUTSIDE OF VEHICLE)

1. Firmly grip pre-tensioner in a vise and cut off the webbing.

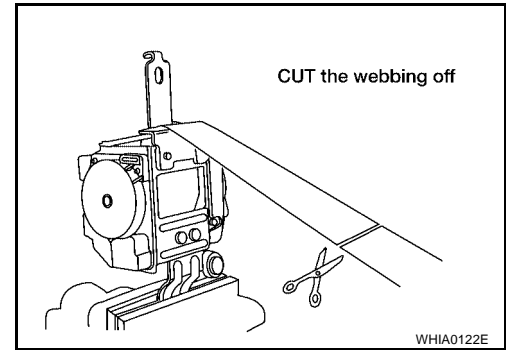

2. Connect deployment tool [SST: KV99106400 (J-38381)] connector to front seat belt pre-tensioner using deployment tool adapter (J-38381-80).

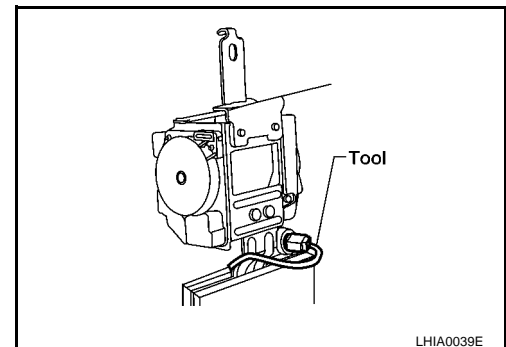

3. Connect red clip of deployment tool to battery positive terminal and black clip to negative terminal.
4. The lamp on the right side of the tool, marked "deployment tool power", should glow green, not red.
5. Press the button on the deployment tool. The left side lamp on the tool, marked "seat belt pre-tensioner connector voltage", will illuminate and the seat belt pre-tensioner will deploy.

CAUTION:

When deploying the front seat belt pre-tensioner, stand at least 5 m (16 ft) away from the seat belt pre-tensioner.

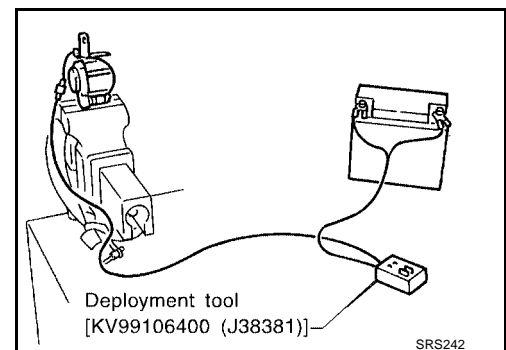

DEPLOYMENT OF AIR BAG MODULES AND SEAT BELT PRE-TENSIONERS WHILE MOUNTED IN VEHICLE

When disposing of a vehicle, deploy air bag modules and seat belt pre-tensioners while they are mounted in vehicle.

CAUTION:

When deploying air bag module or seat belt pre-tensioner, ensure vehicle is empty.

1. Disconnect both the vehicle battery cables and wait 3 minutes.
2. Disconnect all air bag module and seat belt pre-tensioner harness connectors.
3. Connect deployment tool [SST: KV99106400 (J-38381)] to air bag module or seat belt pre-tensioner.
For driver air bag module, use deployment tool adapter (J-38381-80).
For front passenger air bag module, use deployment tool adapter (J-38381-65).
For side curtain air bag module, use deployment tool adapter (J-38381-80).
For side air bag module, use deployment tool adapter [SST: KV99109000 (J-44230)].

A
B
C
D
E
F
G
SRS
I
J
K
L
M

DISPOSAL OF AIR BAG MODULE AND SEAT BELT PRE-TENSIONER

4. Connect red clip of deployment tool to battery positive terminal and black clip to negative terminal.
5. The lamp on the right side of the tool, marked "deployment tool power", should glow green, not red.
6. Press the button on the deployment tool. The left side lamp on the tool, marked "air bag connector voltage", will illuminate and the air bag module or seat belt pre-tensioner will deploy.

CAUTION:

Deploy only one air bag module or seat belt pre-tensioner at a time.

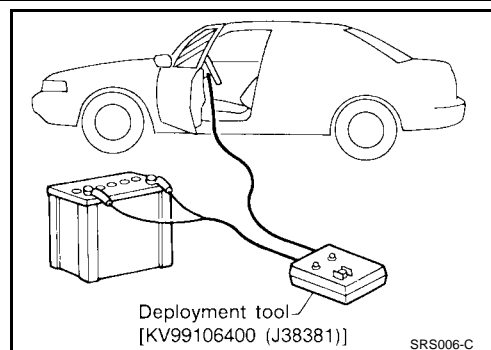

DISPOSING OF AIR BAG MODULE AND SEAT BELT PRE-TENSIONER

Deployed air bag modules and seat belt pre-tensioners are very hot. Before disposing of air bag module or seat belt pre-tensioner, wait at least 30 minutes or 10 minutes, respectively. Seal them in a plastic bag before disposal.

CAUTION:

- Never apply water to a deployed air bag module or seat belt pre-tensioner.
- Be sure to wear gloves when handling a deployed air bag module or seat belt pre-tensioner.
- No poisonous gas is produced upon air bag module deployment. However, be careful not to inhale gas since it irritates the throat and can cause choking.
- Do not disassemble air bag module or seat belt pre-tensioner.
- Air bag modules and seat belt pre-tensioners cannot be reused.
- Wash your hands thoroughly after finishing work.

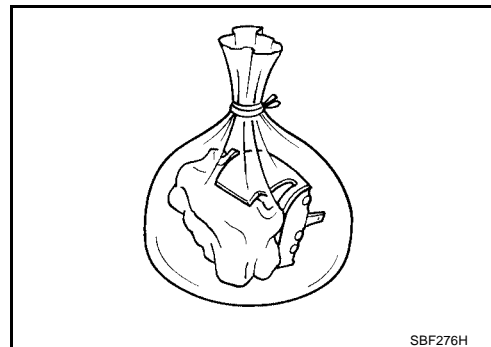

COLLISION DIAGNOSIS

COLLISION DIAGNOSIS

PFP:00015

For Frontal Collision

EHS001DD

Check the SRS components using the following table.

- After the work is completed, perform self-diagnosis to check that no malfunction is detected. Refer to [SRS-21, "SRS Operation Check"](#).

SRS INSPECTION (FOR FRONTAL COLLISION)

Part	SRS is activated	SRS is NOT activated
Air bag module (driver and front passenger air bag module)	REPLACE Install with new fasteners.	<ol style="list-style-type: none"> Remove air bag module. Check harness cover and connectors for damage, terminals for deformities, and harness for binding. Install driver air bag module into the steering wheel to check fit and alignment with the wheel. Install passenger air bag module into the instrument panel to check fit with the instrument panel. If no damage is found, reinstall with new fasteners. If damaged—REPLACE. Install air bag modules with new fasteners. Air bag modules must be deployed before disposal.
Crash zone sensor	REPLACE the crash zone sensor and bracket with new fasteners.	<ol style="list-style-type: none"> Remove the crash zone sensor. Check harness connectors for damage, terminals for deformities, and harness for binding. Check for visible signs of damage (dents, cracks, deformation) of the crash zone sensor and bracket. Install the crash zone sensor to check fit. If no damage is found, reinstall with new fasteners. If damaged—REPLACE the crash zone sensor and bracket with new fasteners.
Seat belt pre-tensioner assemblies	REPLACE Install seat belt pre-tensioner assemblies with new fasteners.	<ol style="list-style-type: none"> Remove seat belt pre-tensioner assemblies. Check harness cover and connectors for damage, terminals for deformities, and harness for binding. Check belts for damage and anchors for loose mounting. Check retractor for smooth operation. Check seat belt adjuster for damage. If no damage is found, reinstall seat belt pre-tensioner assemblies. If damaged—REPLACE. Install the seat belt pre-tensioner assemblies with new fasteners. Seat belt pre-tensioners must be deployed before disposal.
Diagnosis sensor unit	REPLACE Install with new fasteners.	<ol style="list-style-type: none"> Check case for dents, cracks or deformities. Check connectors for damage, and terminals for deformities. If no damage is found, reinstall with new fasteners. If damaged—REPLACE. Install diagnosis sensor unit with new fasteners.
Steering wheel		<ol style="list-style-type: none"> Visually check steering wheel for deformities. Check harness (built into steering wheel) and connectors for damage, and terminals for deformities. Install driver air bag module into the steering wheel to check fit and alignment with the wheel. Check steering wheel for excessive free play. If no damage is found, reinstall. If damaged—REPLACE.
Spiral cable	REPLACE the spiral cable.	<ol style="list-style-type: none"> Visually check spiral cable and combination switch for damage. Check connectors and protective tape for damage. Check steering wheel for noise, binding or heavy operation. If no damage is found, reinstall. If damaged—REPLACE.

A
B
C
D
E
F
G
H
I
J
K
L
M

SRS

COLLISION DIAGNOSIS

Part	SRS is activated	SRS is NOT activated
Occupant classification system (Passenger seat)	<ol style="list-style-type: none"> 1. Remove passenger seat. 2. Check control unit case for dents, cracks or deformities. 3. Check connectors and pressure sensor tube for damage, and terminals for deformities. 4. Check seat frame and cushion pan for dents or deformities. 5. If no damage is found, reinstall seat with new fasteners. 6. If damaged — REPLACE seat cushion assembly with new fasteners. 	
Harness and connectors	<ol style="list-style-type: none"> 1. Check connectors for poor connection, damage, and terminals for deformities. 2. Check harness for binding, chafing, cuts, or deformities. 3. If no damage is found, reinstall the harness and connectors. 4. If damaged—REPLACE the damaged harness. Do not attempt to repair, splice or modify any SRS harness. 	
Instrument panel	REPLACE the instrument panel assembly.	<ol style="list-style-type: none"> 1. Visually check instrument panel for damage. 2. If no damage is found, reinstall the instrument panel. 3. If damaged—REPLACE the instrument panel.

For Side Collision

EHS001DE

Check the SRS components using the following table.

- After the work is completed, perform self-diagnosis to check that no malfunction is detected. Refer to [SRS-21, "SRS Operation Check"](#) .

WHEN SRS IS ACTIVATED IN THE SIDE COLLISION

1. Replace the following components:
 - Front seat back assembly (on the side on which side air bag is activated)
 - Diagnosis sensor unit
 - (LH or RH) side air bag (satellite) sensor (on the side on which side air bag is activated)
2. Check the SRS components and the related parts using the following table.
 - Replace any SRS components and the related parts showing visible signs of damage (dents, cracks, deformation).
3. Conduct self-diagnosis using CONSULT-II and “AIR BAG” warning lamp. Refer to [SRS-21, "SRS Operation Check"](#) for details. Ensure entire SRS operates properly.

WHEN SRS IS NOT ACTIVATED IN THE SIDE COLLISION

1. Check the SRS components and the related parts using the following table.
 - If the front seat back assembly is damaged, the front seat back assembly must be replaced.
2. Conduct self-diagnosis using CONSULT-II and “AIR BAG” warning lamp. Refer to [SRS-21, "SRS Operation Check"](#) for details. Ensure entire SRS operates properly.

SRS INSPECTION (FOR SIDE COLLISION)

Part	SRS is activated	SRS is NOT activated
(LH or RH) side curtain air bag module	Replace the side curtain air bag module. (Repair the center pillar inner, etc. before installing new one if damaged.)	<ol style="list-style-type: none"> 1. Check for visible signs of damage (dents, tears, deformation) of the center pillar on the collision side. 2. If damaged—Remove the side curtain air bag module. 3. Check for visible signs of damaged (tears etc.) of the side curtain air bag module. 4. Check harness and connectors for damage, and terminals for deformities. 5. If no damage is found, reinstall the side curtain air bag module with new fasteners. 6. If damaged—REPLACE the side curtain air bag module with new fasteners. Air bag modules must be deployed before disposal.
Front (LH or RH) side air bag module	REPLACE front seatback assembly.	<ol style="list-style-type: none"> 1. Check for visible signs of damage (dents, tears, deformation) of the seatback on the collision side. 2. Check harness and connectors for damage, and terminals for deformities. 3. If damaged—REPLACE the front seatback assembly.

COLLISION DIAGNOSIS

Part	SRS is activated	SRS is NOT activated
(LH or RH) side air bag (satellite) sensor	REPLACE the side air bag (satellite) sensor on the collision side with new fasteners. (Repair the center pillar inner, etc. before installing new one if damaged.)	<ol style="list-style-type: none"> 1. Remove the side air bag (satellite) sensor on the collision side. Check harness connectors for damage, terminals for deformities, and harness for binding. 2. Check for visible signs of damage (dents, cracks, deformation) of the side air bag (satellite) sensor. 3. Install the side air bag (satellite) sensor to check fit. 4. If no damage is found, reinstall the side air bag (satellite) sensor with new fasteners. 5. If damaged—REPLACE the side air bag (satellite) sensor with new fasteners.
Diagnosis sensor unit	REPLACE the diagnosis sensor unit with new fasteners.	<ol style="list-style-type: none"> 1. Check case and bracket for dents, cracks or deformities. 2. Check connectors for damage, and terminals for deformities. 3. If no damage is found, reinstall the diagnosis sensor unit with new fasteners. 4. If damaged—REPLACE the diagnosis sensor unit with new fasteners.
Seat belt pre-tensioner assembly	<ol style="list-style-type: none"> 1. Check if the seat belt can be extended smoothly. If the seat belt cannot be extended smoothly, <ul style="list-style-type: none"> – Check for deformities of the center pillar inner. – If the center pillar inner has no damage, REPLACE the seat belt pre-tensioner assembly. 2. Remove the seat belt pre-tensioner assembly on the collision side. Check harness cover and connectors for damage, terminals for deformities, and harness for binding. 3. Check for visible signs of damage (dents, cracks, deformation) of the seat belt pre-tensioner assembly. 4. Check seat belt adjuster for damage. 5. If no damage is found, reinstall the seat belt pre-tensioner assembly. 6. If damaged—REPLACE the seat belt pre-tensioner assembly with new fasteners. The seat belt pre-tensioners must be deployed before disposal. 	
Seat (with front side air bag)	REPLACE front seat-back assembly.	<ol style="list-style-type: none"> 1. Visually check the seat on the collision side. 2. Remove the seat on the collision side and check the following for damage and deformities. <ul style="list-style-type: none"> – Harness, connectors and terminals – Frame and recliner (for front and rear seat), and also adjuster and slides (for front seat) 3. If no damage is found, reinstall the seat. 4. If damaged—REPLACE the damaged seat parts using new fasteners. If the front seat back is damaged, the front seat back assembly must be replaced.
Center inner pillar	<ol style="list-style-type: none"> 1. Check the center inner pillar on the collision side for damage (dents, cracks, deformation). 2. If damaged—REPAIR the center inner pillar. 	
Trim/headlining	<ol style="list-style-type: none"> 1. Check for visible signs of damage (dents, cracks, deformation) of the interior trim on the collision side. 2. If damaged—REPLACE the damaged trim parts. 	

A
B
C
D
E
F
G
I
J
K
L
M

SRS

For Rollover

EHS001DF

Check the SRS components using the following table.

- After the work is completed, perform self-diagnosis to check that no malfunction is detected. Refer to [SRS-21, "SRS Operation Check"](#).

WHEN SRS IS ACTIVATED IN THE ROLLOVER

1. Replace the following components:
 - Diagnosis sensor unit
 - (LH or RH) side air bag (satellite) sensor (on the side on which side air bag is activated)
2. Check the SRS components and the related parts using the following table.
 - Replace any SRS components and the related parts showing visible signs of damage (dents, cracks, deformation).
3. Conduct self-diagnosis using CONSULT-II and "AIR BAG" warning lamp. Refer to [SRS-21, "SRS Operation Check"](#) for details. Ensure entire SRS operates properly.

WHEN SRS IS NOT ACTIVATED IN THE ROLLOVER

1. Check the SRS components and the related parts using the following table.

COLLISION DIAGNOSIS

- If the front seatback assembly is damaged, the front seatback assembly must be replaced.
- 2. Conduct self-diagnosis using CONSULT-II and "AIR BAG" warning lamp. Refer to [SRS-21, "SRS Operation Check"](#) for details. Ensure entire SRS operates properly.

SRS INSPECTION (FOR ROLLOVER)

Part	SRS is activated	SRS is NOT activated
(LH or RH) side curtain air bag module	Replace the side curtain air bag module. (Repair the center pillar inner, etc. before installing new one if damaged.)	<ol style="list-style-type: none"> 1. Check for visible signs of damage (dents, tears, deformation) of the center pillar on the collision side. 2. If damaged—Remove the side curtain air bag module. 3. Check for visible signs of damaged (tears etc.) of the side curtain air bag module. 4. Check harness and connectors for damage, and terminals for deformities. 5. If no damage is found, reinstall the side curtain air bag module with new fasteners. 6. If damaged—REPLACE the side curtain air bag module with new fasteners. Air bag modules must be deployed before disposal.
Front (LH or RH) side air bag module	REPLACE front seatback assembly.	<ol style="list-style-type: none"> 1. Check for visible signs of damage (dents, tears, deformation) of the seat back on the collision side. 2. Check harness and connectors for damage, and terminals for deformities. 3. If damaged—REPLACE the front seatback assembly.
(LH or RH) side air bag (satellite) sensor	REPLACE the side air bag (satellite) sensor on the collision side with new fasteners. (Repair the center pillar inner, etc. before installing new one if damaged.)	<ol style="list-style-type: none"> 1. Remove the side air bag (satellite) sensor on the collision side. Check harness connectors for damage, terminals for deformities, and harness for binding. 2. Check for visible signs of damage (dents, cracks, deformation) of the side air bag (satellite) sensor. 3. Install the side air bag (satellite) sensor to check fit. 4. If no damage is found, reinstall the side sir bag (satellite) sensor with new fasteners. 5. If damaged—REPLACE the side air bag (satellite) sensor with new fasteners.
Diagnosis sensor unit	REPLACE the diagnosis sensor unit with new fasteners.	<ol style="list-style-type: none"> 1. Check case and bracket for dents, cracks or deformities. 2. Check connectors for damage, and terminals for deformities. 3. If no damage is found, reinstall the diagnosis sensor unit with new fasteners. 4. If damaged—REPLACE the diagnosis sensor unit with new fasteners.
Seat belt pre-tensioner assembly	<ol style="list-style-type: none"> 1. Check if the seat belt can be extended smoothly. If the seat belt cannot be extended smoothly, <ul style="list-style-type: none"> - Check for deformities of the center pillar inner. - If the center pillar inner has no damage, REPLACE the seat belt pre-tensioner assembly. 2. Remove the seat belt pre-tensioner assembly on the collision side. Check harness cover and connectors for damage, terminals for deformities, and harness for binding. 3. Check for visible signs of damage (dents, cracks, deformation) of the seat belt pre-tensioner assembly. 4. Check seat belt adjuster for damage. 5. If no damage is found, reinstall the seat belt pre-tensioner assembly. 6. If damaged—REPLACE the seat belt pre-tensioner assembly with new fasteners. The seat belt pre-tensioner assemblies must be deployed before disposal. 	
Seat (with front side air bag)	REPLACE front seatback assembly.	<ol style="list-style-type: none"> 1. Visually check the seat on the collision side. 2. Remove the seat on the collision side and check the following for damage and deformities. <ul style="list-style-type: none"> - Harness, connectors and terminals - Frame and recliner (for front and rear seat), and also adjuster and slides (for front seat) 3. If no damage is found, reinstall the seat. 4. If damaged—REPLACE the damaged seat parts using new fasteners. If the front seatback is damaged, the front seatback assembly must be replaced.
Center inner pillar	<ol style="list-style-type: none"> 1. Check the center inner pillar on the collision side for damage (dents, cracks, deformation). 2. If damaged—REPAIR the center inner pillar. 	
Trim/headlining	<ol style="list-style-type: none"> 1. Check for visible signs of damage (dents, cracks, deformation) of the interior trim on the collision side. 2. If damaged—REPLACE the damaged trim parts. 	