

SECTION **PG**

POWER SUPPLY, GROUND & CIRCUIT ELEMENTS

CONTENTS

PRECAUTIONS	3	GROUND CIRCUIT	29
Precautions for Supplemental Restraint System (SRS) "AIR BAG" and "SEAT BELT PRE-TENSIONER"	3	Ground Distribution	29
Wiring Diagrams and Trouble Diagnosis	3	MAIN HARNESS	29
POWER SUPPLY ROUTING CIRCUIT	4	ENGINE ROOM HARNESS	32
Schematic	4	ENGINE CONTROL HARNESS	35
Wiring Diagram — POWER —	6	BODY HARNESS	36
BATTERY POWER SUPPLY — IGNITION SW. IN ANY POSITION	6	BODY NO. 2 HARNESS	37
ACCESSORY POWER SUPPLY — IGNITION SW. IN ACC OR ON	11	HARNESS	38
IGNITION POWER SUPPLY — IGNITION SW. IN ON	12	Harness Layout	38
IGNITION POWER SUPPLY — IGNITION SW. IN ON AND/OR START	13	HOW TO READ HARNESS LAYOUT	38
IPDM E/R (INTELLIGENT POWER DISTRIBUTION MODULE ENGINE ROOM)	16	OUTLINE (KING CAB MODELS)	39
System Description	16	OUTLINE (CREW CAB MODELS)	40
SYSTEMS CONTROLLED BY IPDM E/R	16	MAIN HARNESS	41
CAN COMMUNICATION LINE CONTROL	16	ENGINE ROOM HARNESS (LH VIEW)	43
IPDM E/R STATUS CONTROL	17	ENGINE ROOM HARNESS (RH VIEW)	46
CAN Communication System Description	17	ENGINE CONTROL HARNESS	48
Function of Detecting Ignition Relay Malfunction ...	17	CHASSIS HARNESS	50
CONSULT-II Function	18	BODY HARNESS (KING CAB MODELS)	52
CONSULT-II BASIC OPERATION	18	BODY HARNESS (CREW CAB MODELS)	54
SELF-DIAGNOSTIC RESULTS	19	BODY NO. 2 HARNESS (KING CAB MODELS)..	56
DATA MONITOR	19	BODY NO. 2 HARNESS (CREW CAB MODELS)..	58
ACTIVE TEST	21	ROOM LAMP HARNESS	60
Auto Active Test	22	FRONT DOOR HARNESS LH	61
DESCRIPTION	22	FRONT DOOR HARNESS RH	61
OPERATION PROCEDURE	22	REAR DOOR HARNESS LH (CREW CAB MODELS)	62
INSPECTION IN AUTO ACTIVE TEST MODE ...	22	REAR DOOR HARNESS RH (CREW CAB MODELS)	62
Schematic	24	Wiring Diagram Codes (Cell Codes)	63
IPDM E/R Terminal Arrangement	25	ELECTRICAL UNITS LOCATION	65
IPDM E/R Power/Ground Circuit Inspection	26	Electrical Units Location	65
Inspection with CONSULT-II (Self-Diagnosis)	27	ENGINE COMPARTMENT	65
Removal and Installation of IPDM E/R	28	PASSENGER COMPARTMENT	66
REMOVAL	28	Fuse	68
INSTALLATION	28	Fusible Link	68
		Circuit Breaker (Built Into BCM)	68
		HARNESS CONNECTOR	69
		Description	69
		HARNESS CONNECTOR (TAB-LOCKING	

TYPE)	69	MIXED TYPE RELAYS	73
HARNESS CONNECTOR (SLIDE-LOCKING TYPE)	70	TYPE OF STANDARDIZED RELAYS	73
HARNESS CONNECTOR (DIRECT-CONNECT SRS COMPONENT TYPE)	71	SUPER MULTIPLE JUNCTION (SMJ)	75
ELECTRICAL UNITS	72	Terminal Arrangement	75
Terminal Arrangement	72	FUSE BLOCK-JUNCTION BOX(J/B)	77
STANDARDIZED RELAY	73	Terminal Arrangement	77
Description	73	FUSE AND FUSIBLE LINK BOX	78
NORMAL OPEN, NORMAL CLOSED AND		Terminal Arrangement	78
		FUSE AND RELAY BOX	79
		Terminal Arrangement	79

PRECAUTIONS

PRECAUTIONS

PFP:00011

Precautions for Supplemental Restraint System (SRS) “AIR BAG” and “SEAT BELT PRE-TENSIONER”

EKS00AR4

The Supplemental Restraint System such as “AIR BAG” and “SEAT BELT PRE-TENSIONER”, used along with a front seat belt, helps to reduce the risk or severity of injury to the driver and front passenger for certain types of collision. This system includes seat belt switch inputs and dual stage front air bag modules. The SRS system uses the seat belt switches to determine the front air bag deployment, and may only deploy one front air bag, depending on the severity of a collision and whether the front occupants are belted or unbelted. Information necessary to service the system safely is included in the SRS and SB section of this Service Manual.

WARNING:

- To avoid rendering the SRS inoperative, which could increase the risk of personal injury or death in the event of a collision which would result in air bag inflation, all maintenance must be performed by an authorized NISSAN/INFINITI dealer.
- Improper maintenance, including incorrect removal and installation of the SRS, can lead to personal injury caused by unintentional activation of the system. For removal of Spiral Cable and Air Bag Module, see the SRS section.
- Do not use electrical test equipment on any circuit related to the SRS unless instructed to in this Service Manual. SRS wiring harnesses can be identified by yellow and/or orange harnesses or harness connectors.

Wiring Diagrams and Trouble Diagnosis

EKS00AR5

When you read wiring diagrams, refer to the following:

- Refer to [GI-14, "How to Read Wiring Diagrams"](#) in GI section.
- Refer to [PG-4, "POWER SUPPLY ROUTING CIRCUIT"](#) for power distribution.

When you perform trouble diagnosis, refer to the following:

- Refer to [GI-11, "HOW TO FOLLOW TEST GROUPS IN TROUBLE DIAGNOSES"](#) in GI section.
- Refer to [GI-27, "How to Perform Efficient Diagnosis for an Electrical Incident"](#) in GI section.

A

B

C

D

E

F

G

H

I

J

PG

L

M

POWER SUPPLY ROUTING CIRCUIT

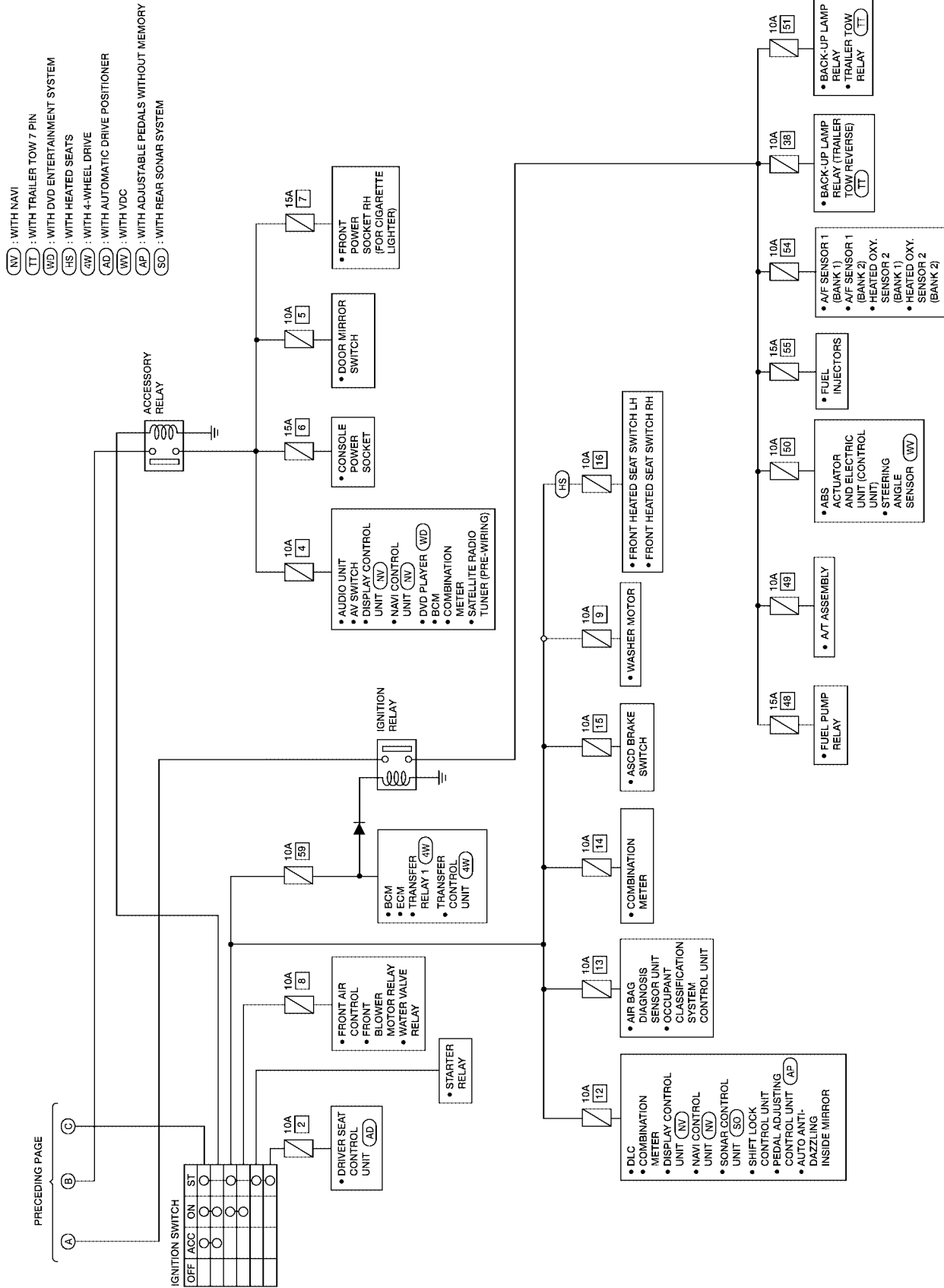

A
B
C
D
E
F
G
H
I
J
K
L
M

POWER SUPPLY ROUTING CIRCUIT

Wiring Diagram — POWER — BATTERY POWER SUPPLY — IGNITION SW. IN ANY POSITION

EKS00AR7

PG-POWER-01

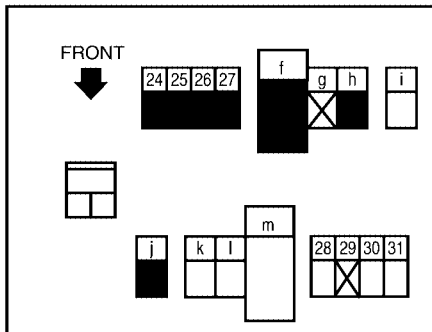
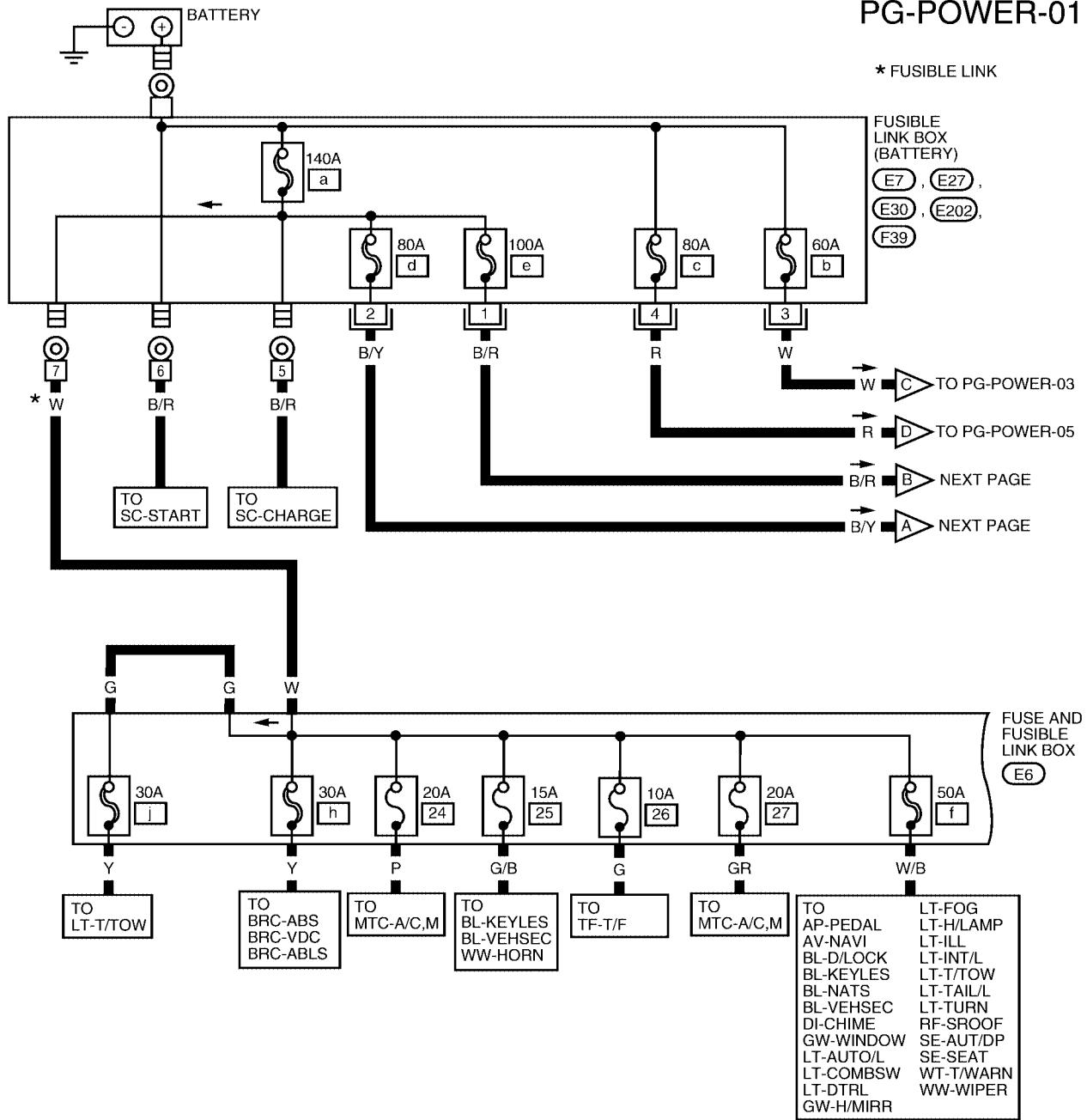

E6

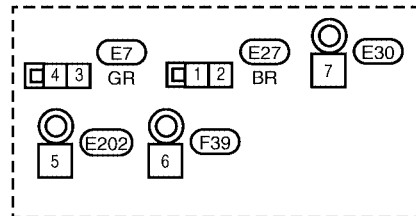

WKWA2610E

POWER SUPPLY ROUTING CIRCUIT

PG-POWER-02

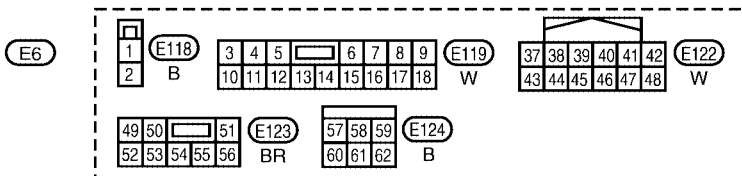
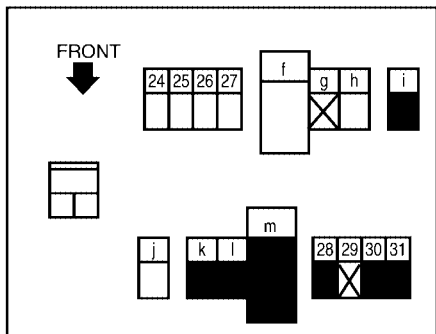
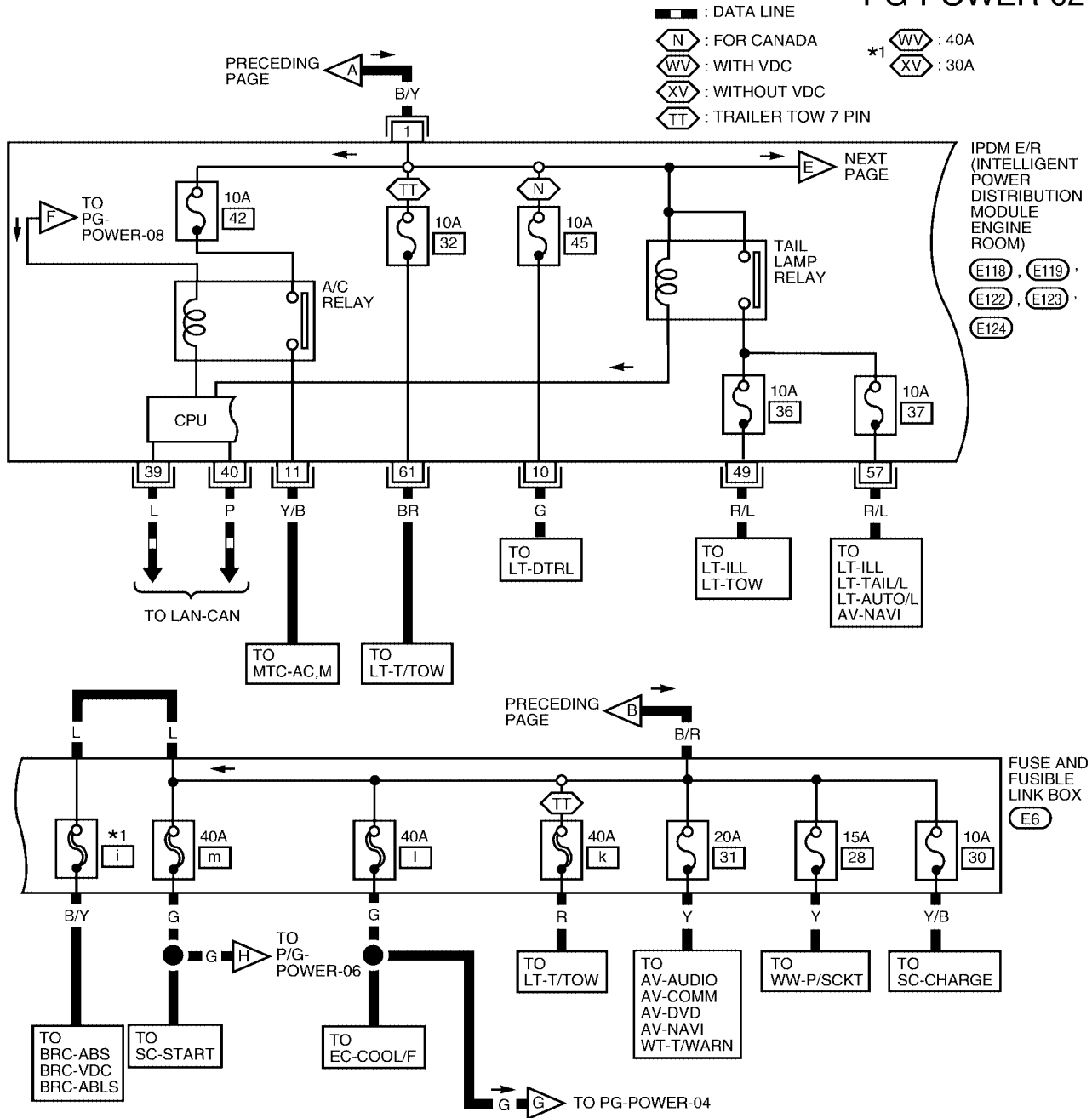

WKWA2611E

POWER SUPPLY ROUTING CIRCUIT

PG-POWER-03

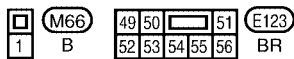
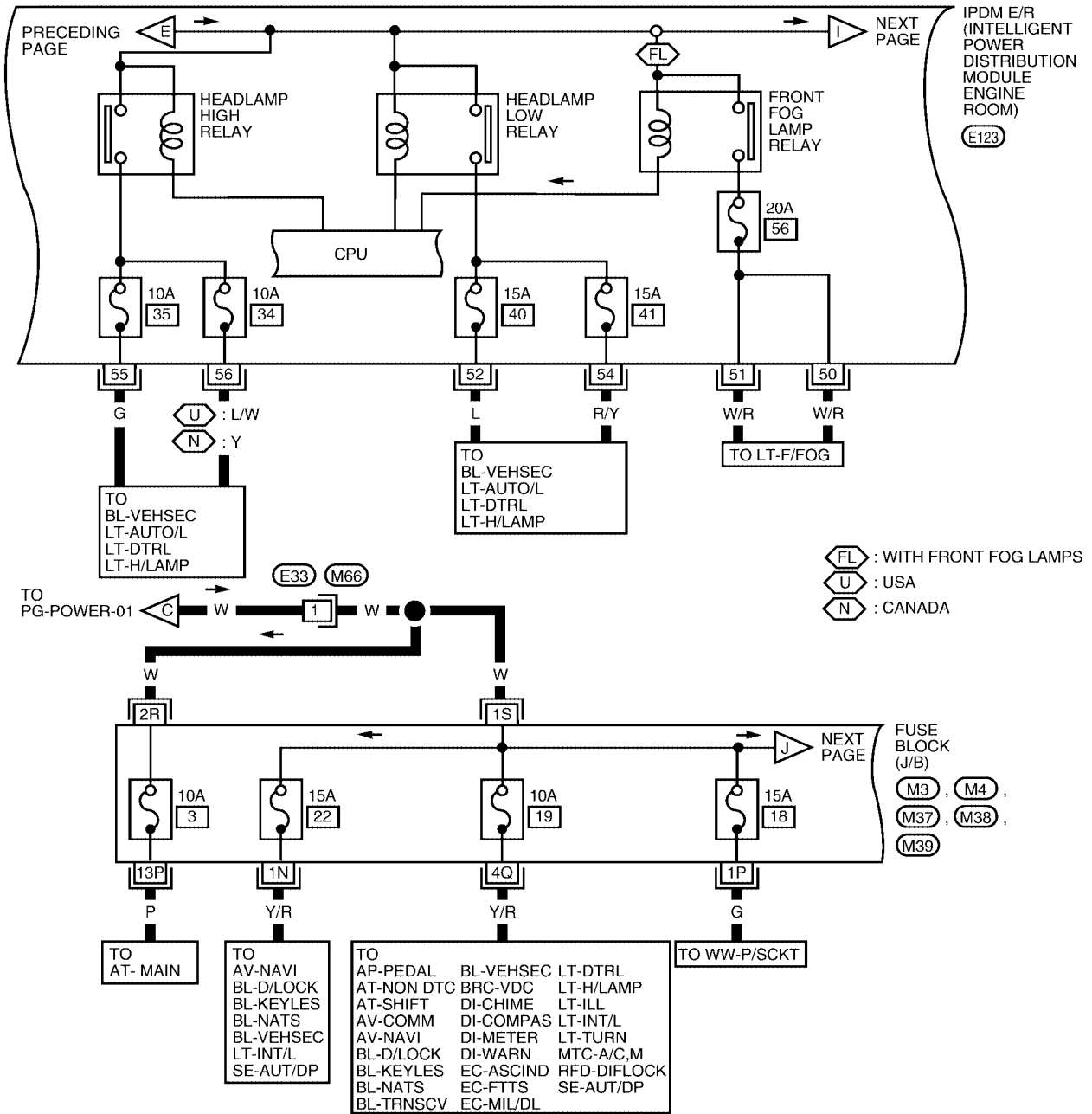

REFER TO THE FOLLOWING.

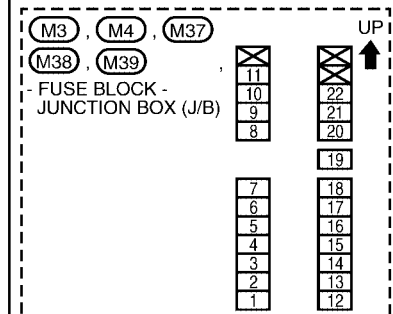

WKWA2612E

POWER SUPPLY ROUTING CIRCUIT

PG-POWER-04

HM : WITH HEATED MIRRORS

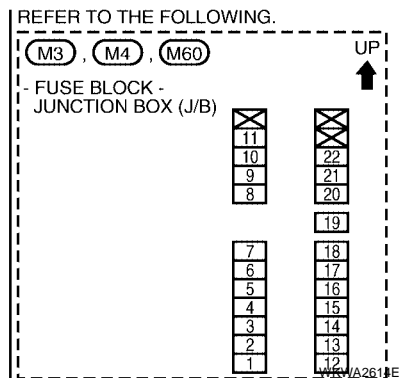
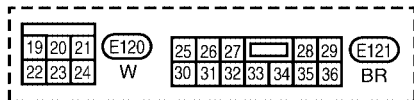
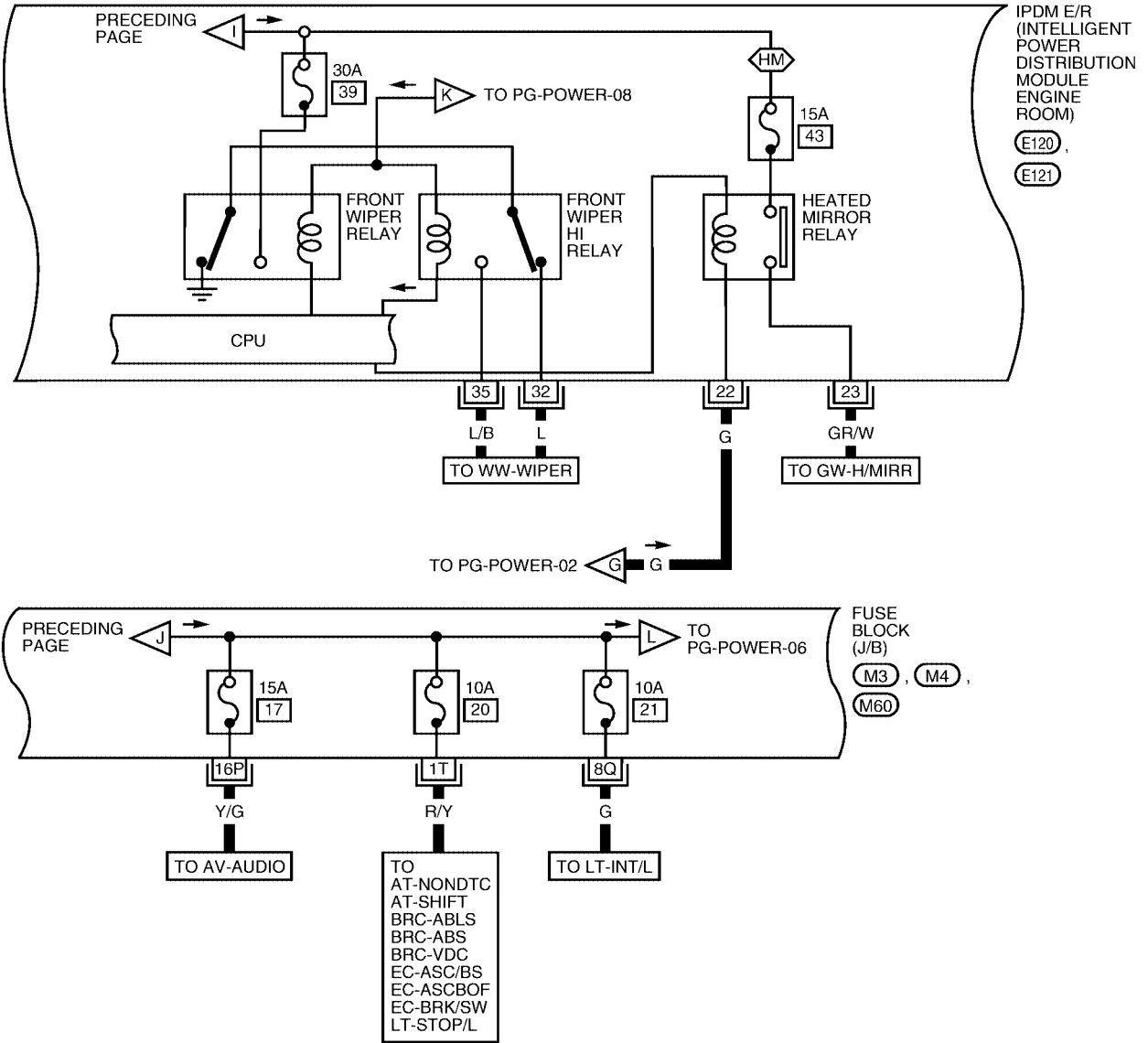

POWER SUPPLY ROUTING CIRCUIT

PG-POWER-05

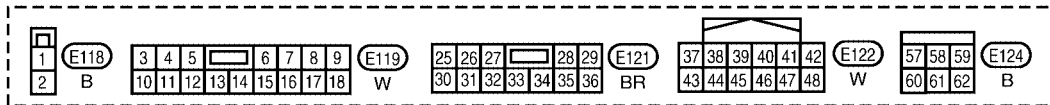
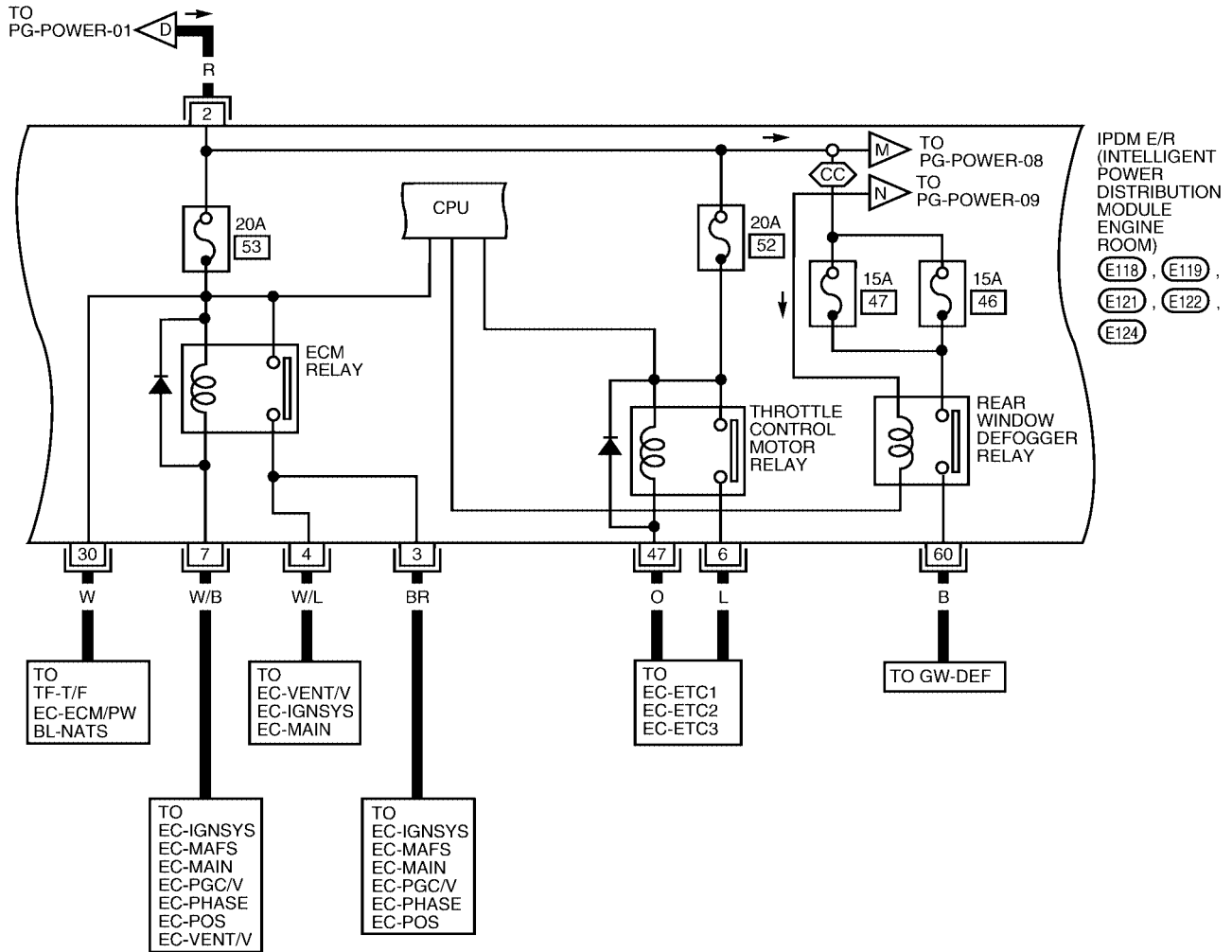

WKWA2629E

POWER SUPPLY ROUTING CIRCUIT

ACCESSORY POWER SUPPLY — IGNITION SW. IN ACC OR ON

PG-POWER-06

A
B
C
D
E
F
G
H
I
J
PG
L
M

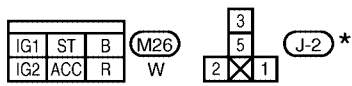
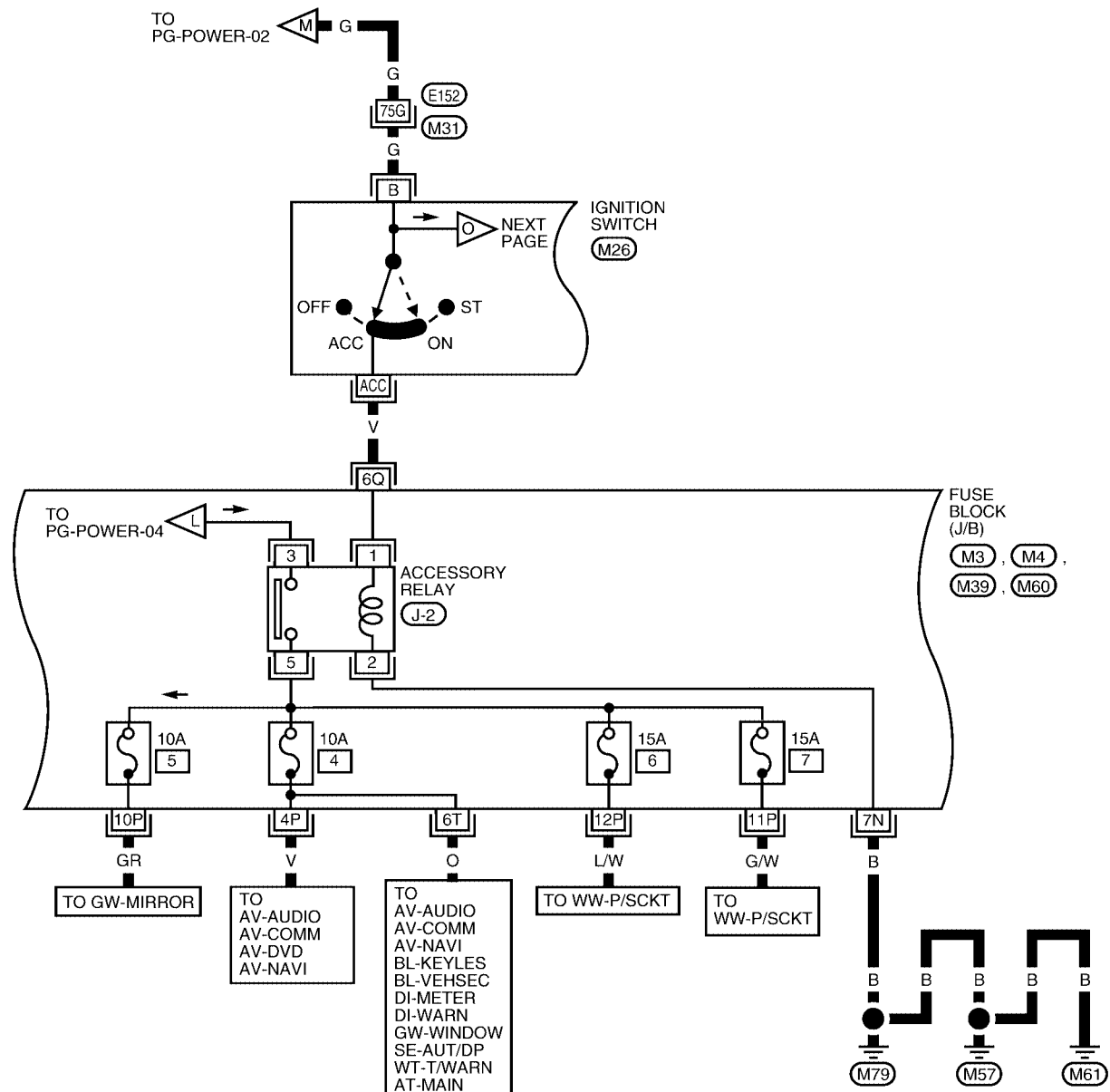

*: THIS CONNECTOR IS NOT SHOWN IN "HARNESS LAYOUT".

REFER TO THE FOLLOWING.

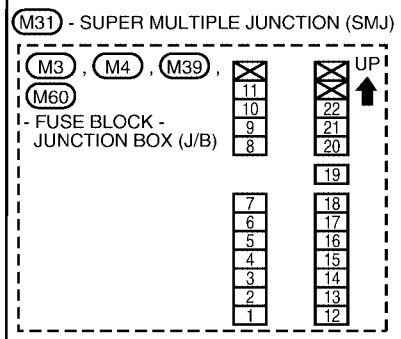

WKWA2631E

POWER SUPPLY ROUTING CIRCUIT

IGNITION POWER SUPPLY — IGNITION SW. IN ON

PG-POWER-07

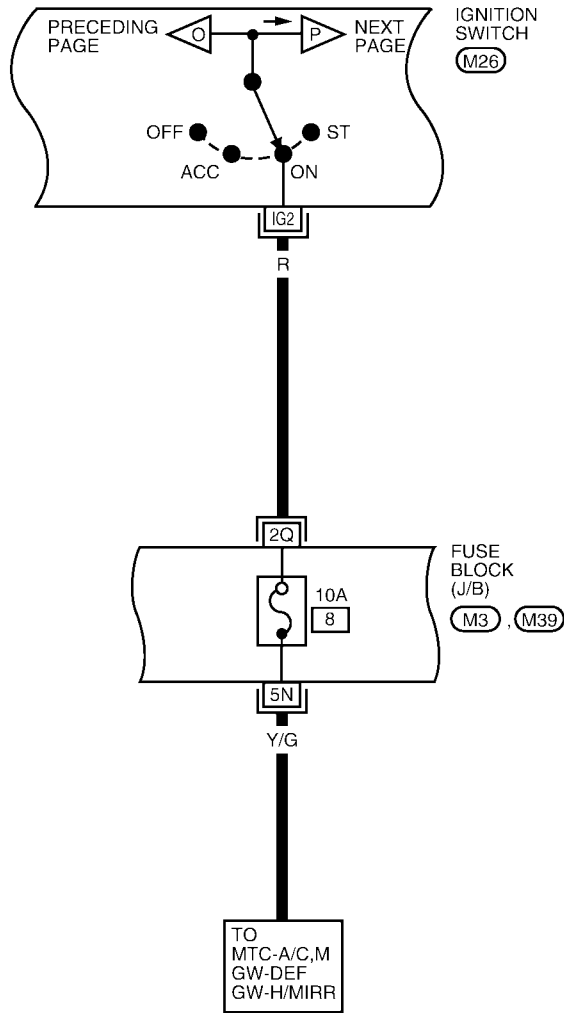

IG1	ST	B	(M26)
IG2	ACC	R	

W

REFER TO THE FOLLOWING.

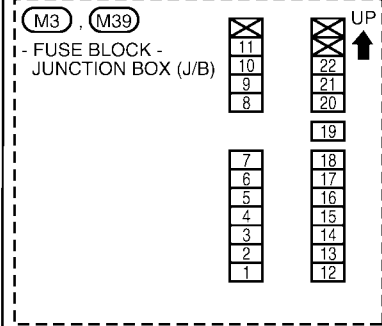

WKWA2632E

POWER SUPPLY ROUTING CIRCUIT

IGNITION POWER SUPPLY — IGNITION SW. IN ON AND/OR START

PG-POWER-08

WV : WITH VDC
 XV : EXCEPT VDC

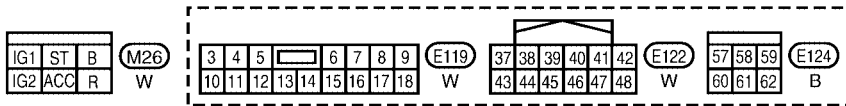
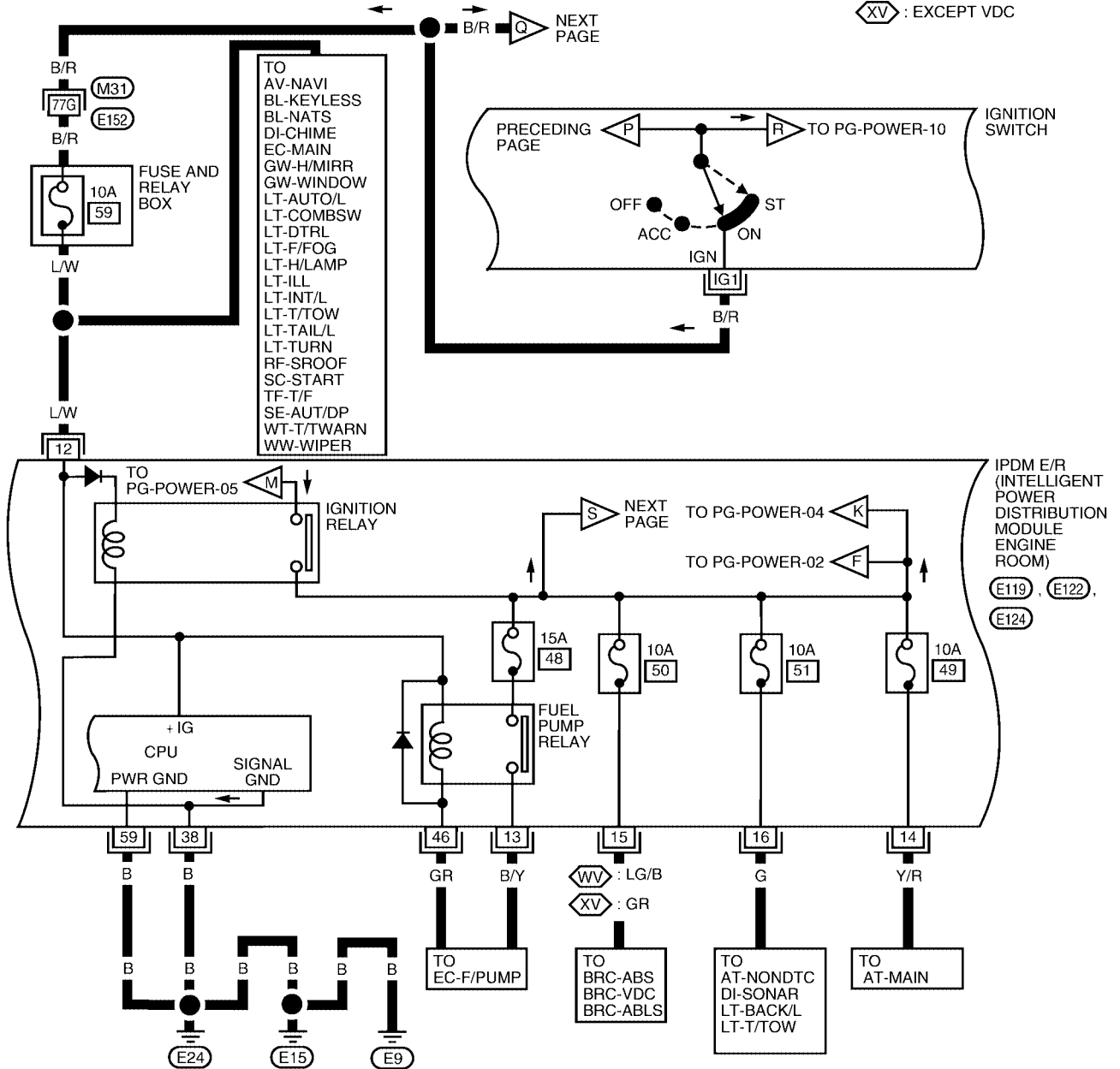

A
B
C
D
E
F
G
H
I
J
K
L
M

PG

POWER SUPPLY ROUTING CIRCUIT

PG-POWER-09

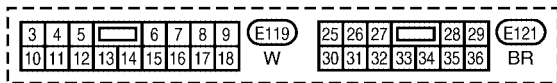
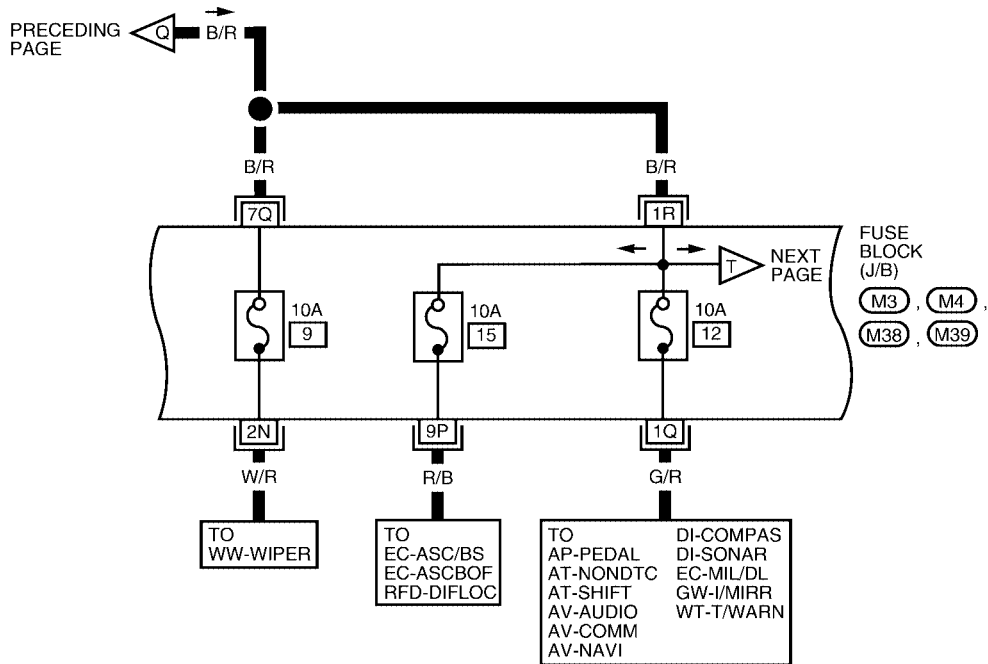
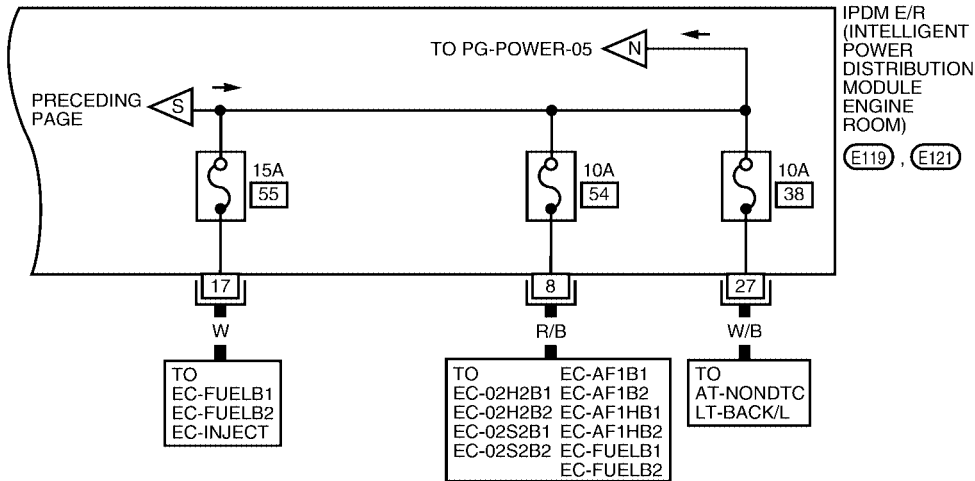

REFER TO THE FOLLOWING.

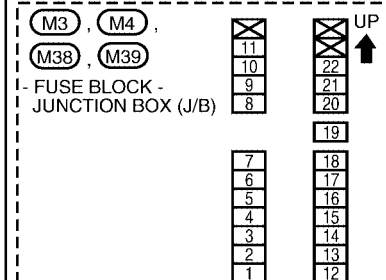

WKVA2634E

POWER SUPPLY ROUTING CIRCUIT

PG-POWER-10

A
B
C
D
E
F
G
H
I
J
PG
L
M

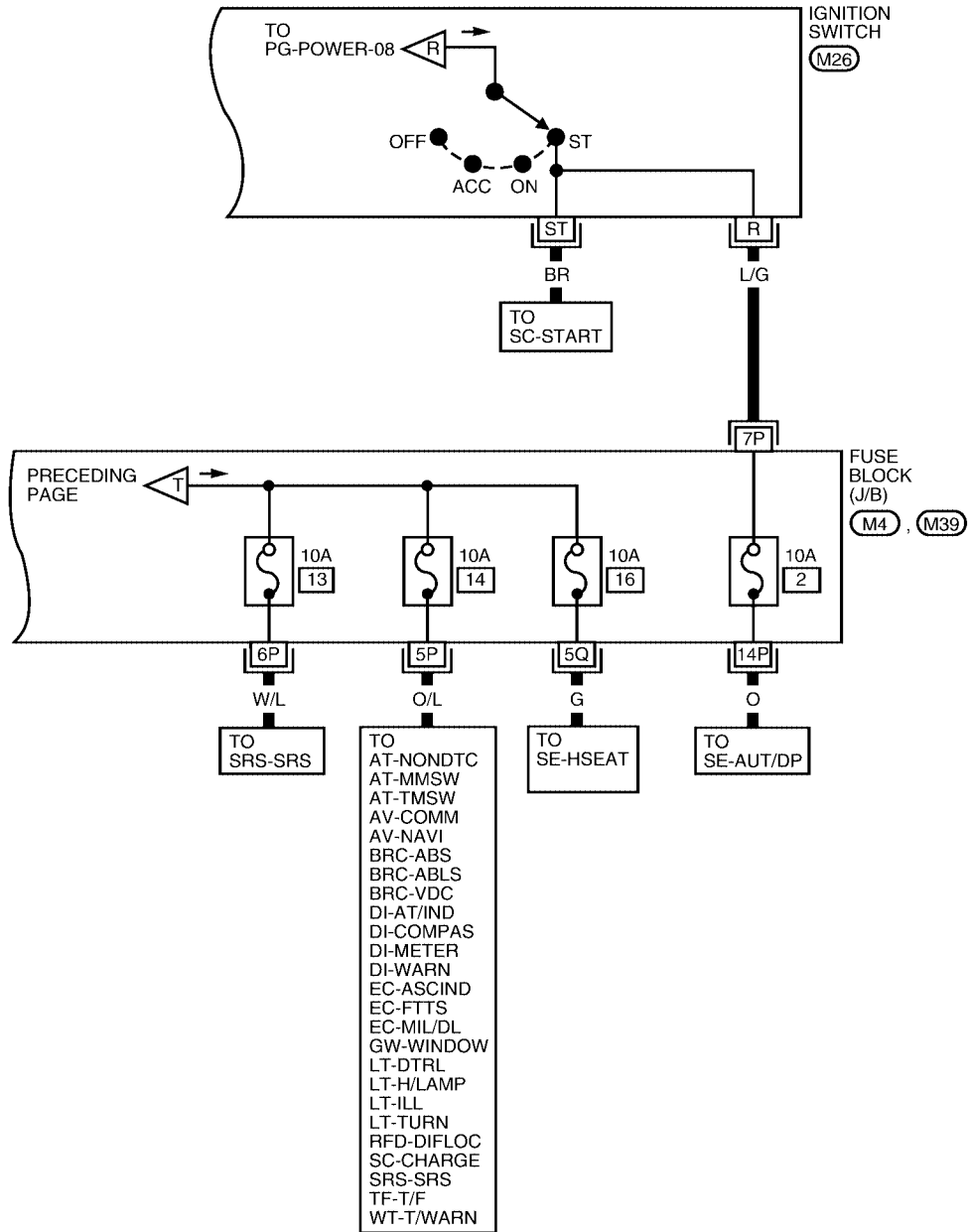

IG1	ST	B	(M26) W
IG2	ACC	R	

REFER TO THE FOLLOWING.

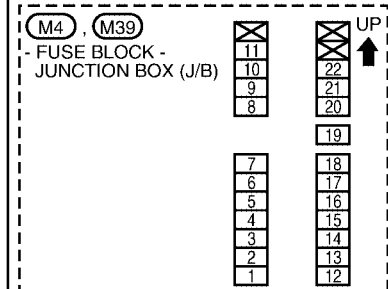

WKWA2635E

IPDM E/R (INTELLIGENT POWER DISTRIBUTION MODULE ENGINE ROOM)

IPDM E/R (INTELLIGENT POWER DISTRIBUTION MODULE ENGINE ROOM)

PF2:284B7

System Description

EKS00AR8

- IPDM E/R (Intelligent Power Distribution Module Engine Room) integrates the relay box and fuse block which were originally placed in engine compartment. It controls integrated relays via IPDM E/R control circuits.
- IPDM E/R-integrated control circuits perform ON-OFF operation of relays, CAN communication control, etc.
- It controls operation of each electrical component via ECM, BCM and CAN communication lines.

CAUTION:

None of the IPDM E/R integrated relays can be removed.

SYSTEMS CONTROLLED BY IPDM E/R

1. Lamp control
Using CAN communication lines, it receives signals from the BCM and controls the following lamps:
 - Headlamps (Hi, Lo)
 - Parking lamps
 - Tail lamps and license lamps
 - Front fog lamps
2. Wiper control
Using CAN communication lines, it receives signals from the BCM and controls the front wipers.
3. Heated mirror relay control
Using CAN communication lines, it receives signals from the BCM and controls the heated mirror relay.
4. A/C compressor control
Using CAN communication lines, it receives signals from the ECM and controls the A/C compressor (magnetic clutch).
5. Starter control
Using CAN communication lines, it receives signals from the ECM and controls the starter relay.
6. Cooling fan control
Using CAN communication lines, it receives signals from the ECM and controls the cooling fan relays.
7. Horn control
Using CAN communication lines, it receives signals from the BCM and controls the horn relay.

CAN COMMUNICATION LINE CONTROL

With CAN communication, by connecting each control unit using two communication lines (CAN L-line, CAN H-line), it is possible to transmit a maximum amount of information with minimum wiring. Each control unit can transmit and receive data, and reads necessary information only.

1. Fail-safe control
 - When CAN communication with other control units is impossible, IPDM E/R performs fail-safe control. After CAN communication returns to normal operation, it also returns to normal control.
 - Operation of control parts by IPDM E/R during fail-safe mode is as follows:

Controlled system	Fail-safe mode
Headlamp	<ul style="list-style-type: none">● With the ignition switch ON, the headlamp (low) is ON.● With the ignition switch OFF, the headlamp (low) is OFF.
Tail and parking lamps	<ul style="list-style-type: none">● With the ignition switch ON, the tail and parking lamps are ON.● With the ignition switch OFF, the tail and parking lamps are OFF.
Cooling fan	<ul style="list-style-type: none">● With the ignition switch ON, the cooling fan HI operates.● With the ignition switch OFF, the cooling fan stops.
Front wiper	Until the ignition switch is turned off, the front wiper LO and HI remains in the same status it was in just before fail-safe control was initiated.
Heated mirrors	Heated mirror relay OFF
A/C compressor	A/C compressor OFF
Front fog lamps	Front fog lamp relay OFF

IPDM E/R (INTELLIGENT POWER DISTRIBUTION MODULE ENGINE ROOM)

IPDM E/R STATUS CONTROL

In order to save power, IPDM E/R switches status by itself based on each operating condition.

1. CAN communication status
 - CAN communication is normally performed with other control units.
 - Individual unit control by IPDM E/R is normally performed.
 - When sleep request signal is received from BCM, mode is switched to sleep waiting status.
2. Sleep waiting status
 - Process to stop CAN communication is activated.
 - All systems controlled by IPDM E/R are stopped. When 1 second has elapsed after CAN communication with other control units is stopped, mode switches to sleep status.
3. Sleep status
 - IPDM E/R operates in low current-consumption mode.
 - CAN communication is stopped.
 - When a change in CAN communication signal is detected, mode switches to CAN communication status.
 - When a change in ignition switch signal is detected, mode switches to CAN communication status.

CAN Communication System Description

EKS00AR9

Refer to [LAN-7, "CAN COMMUNICATION"](#) .

Function of Detecting Ignition Relay Malfunction

EKS00ARA

- When the integrated ignition relay is stuck in a "closed contact" position and cannot be turned OFF, IPDM E/R turns ON tail and parking lamps for 10 minutes to indicate IPDM E/R malfunction.
- When the state of the integrated ignition relay does not agree with the state of the ignition switch signal received via CAN communication, the IPDM E/R activates the tail lamp relay.

Ignition switch signal	Ignition relay status	Tail lamp relay
ON	ON	—
OFF	OFF	—
ON	OFF	—
OFF	ON	ON (10 minutes)

NOTE:

When the ignition switch is turned ON, the tail lamps are OFF.

IPDM E/R (INTELLIGENT POWER DISTRIBUTION MODULE ENGINE ROOM)

EKS00ARB

CONSULT-II Function

- CONSULT-II can display each diagnostic item using the diagnostic test modes shown following.

Inspection Item, Diagnosis Mode	Description
SELF-DIAG RESULTS	The IPDM E/R performs diagnosis of CAN communication and self-diagnosis.
DATA MONITOR	The input/output data of the IPDM E/R is displayed in real time.
ACTIVE TEST	The IPDM E/R sends a drive signal to electronic components to check their operation.
CAN DIAG SUPPORT MNTR	The result of transmit/receive diagnosis of CAN communication can be read.

CONSULT-II BASIC OPERATION

CAUTION:

If CONSULT-II is used with no connection of CONSULT-II CONVERTER, malfunctions might be detected in self-diagnosis depending on control unit which carry out CAN communication.

- With the ignition switch OFF, connect CONSULT-II and CONSULT-II CONVERTER to the data link connector, then turn ignition switch ON.

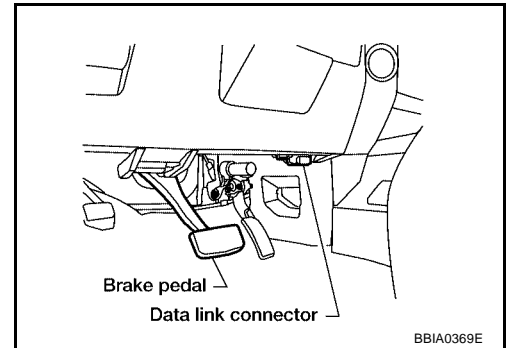

- Touch "START (NISSAN BASED VHCL)".

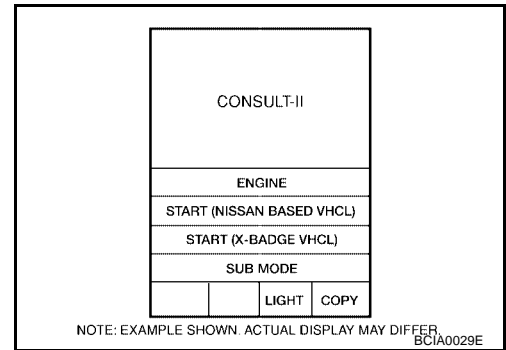

- Touch "IPDM E/R" on "SELECT SYSTEM" screen.
 - If "IPDM E/R" is not displayed, print "SELECT SYSTEM" screen, then refer to [LAN-5, "PRECAUTIONS"](#).

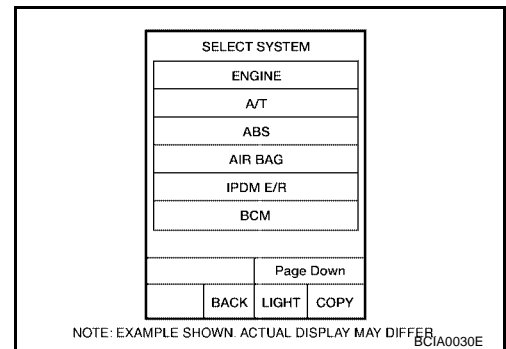

IPDM E/R (INTELLIGENT POWER DISTRIBUTION MODULE ENGINE ROOM)

4. Select "SELF-DIAG RESULTS" or "DATA MONITOR".

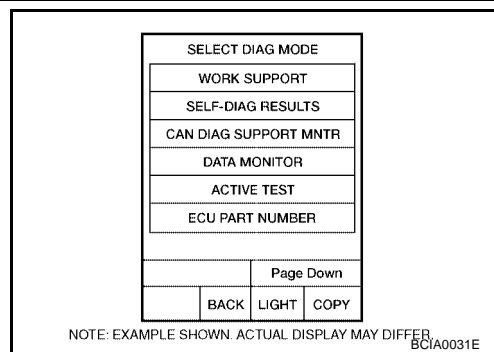

SELF-DIAGNOSTIC RESULTS

Operation Procedure

1. Touch "SELF-DIAG RESULTS" on "SELECT DIAG MODE" screen.
2. Self-diagnosis results are displayed.

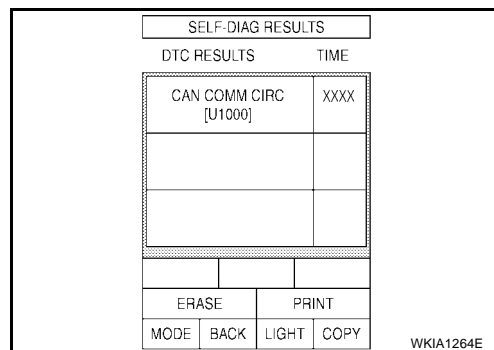

Display Item List

Display items	CONSULT-II display code	Malfunction detection	TIME		Possible causes
			CRNT	PAST	
NO DTC IS DETECTED. FURTHER TESTING MAY BE REQUIRED.	—	—	—	—	—
CAN COMM CIRC	U1000	<ul style="list-style-type: none"> ● If CAN communication reception/transmission data has a malfunction, or if any of the control units fail, data reception/transmission cannot be confirmed. ● When the data in CAN communication is not received before the specified time. 	X	X	Any of items listed below have errors: <ul style="list-style-type: none"> ● TRANSMIT DIAG ● ECM ● BCM/SEC

NOTE:

The details for display of the period are as follows:

- CRNT: Error currently detected with IPDM E/R.
- PAST: Error detected in the past and placed in IPDM E/R memory.

DATA MONITOR

Operation Procedure

1. Touch "DATA MONITOR" on "SELECT DIAG MODE" screen.
2. Touch "ALL SIGNALS", "MAIN SIGNALS" or "SELECT FROM MENU" on the "DATA MONITOR" screen.

ALL SIGNALS	All signals will be monitored.
MAIN SIGNALS	Monitors the predetermined item(s).
SELECT FROM MENU	Selects and monitors individual signal(s).

3. Touch "START".
4. Touch the required monitoring item on "SELECT ITEM MENU".

IPDM E/R (INTELLIGENT POWER DISTRIBUTION MODULE ENGINE ROOM)

5. Touch "RECORD" while monitoring to record the status of the item being monitored. To stop recording, touch "STOP".

IPDM E/R (INTELLIGENT POWER DISTRIBUTION MODULE ENGINE ROOM)

All Signals, Main Signals, Select From Menu

Item name	CONSULT-II screen display	Display or unit	Monitor item selection			Description
			ALL SIGNALS	MAIN SIGNALS	SELECT FROM MENU	
Motor fan request	MOTOR FAN REQ	1/2/3/4	X	X	X	Signal status input from ECM
Compressor request	AC COMP REQ	ON/OFF	X	X	X	Signal status input from ECM
Tail & clear request	TAIL & CLR REQ	ON/OFF	X	X	X	Signal status input from BCM
H/L LO request	HL LO REQ	ON/OFF	X	X	X	Signal status input from BCM
H/L HI request	HL HI REQ	ON/OFF	X	X	X	Signal status input from BCM
FR fog request	FR FOG REQ	ON/OFF	X	X	X	Signal status input from BCM
FR wiper request	FR WIP REQ	STOP/1LOW/LOW/HI	X	X	X	Signal status input from BCM
Wiper auto stop	WIP AUTO STOP	ACT P/STOP P	X	X	X	Output status of IPDM E/R
Wiper protection	WIP PROT	OFF/Block	X	X	X	Control status of IPDM E/R
Starter request	ST RLY REQ	ON/OFF	X		X	Status of input signal ^{NOTE}
Ignition relay status	IGN RLY	ON/OFF	X	X	X	Ignition relay status monitored with IPDM E/R
Rear defogger request (heated mirror)	RR DEF REQ	ON/OFF	X	X	X	Signal status input from BCM
Oil pressure switch	OIL P SW	OPEN/CLOSE	X		X	Signal status input from IPDM E/R
Hood switch	HOOD SW	OFF	X			Signal status input from IPDM E/R (function is not enabled)
Theft warning horn request	THFT HRN REQ	ON/OFF	X		X	Signal status input from BCM
Horn chirp	HORN CHIRP	ON/OFF	X		X	Output status of IPDM E/R
Daytime running lamp request	DTRL REQ	ON/OFF	X		X	Signal status input from BCM

NOTE:

Perform monitoring of IPDM E/R data with the ignition switch ON. When the ignition switch is in ACC position, display may not be correct.

ACTIVE TEST

Operation Procedure

1. Touch "ACTIVE TEST" on "SELECT DIAG-MODE" screen.
2. Touch item to be tested, and check operation.
3. Touch "START".
4. Touch "STOP" while testing to stop the operation.

Test name	CONSULT-II screen display	Description
Heated mirror	REAR DEFOGGER	With a certain ON-OFF operation, the heated mirror relay can be operated.
Front wiper (HI, LO) output	FRONT WIPER	With a certain operation (OFF, HI ON, LO ON), the front wiper relay (Lo, Hi) can be operated.
Cooling fan output	MOTOR FAN	With a certain operation (1, 2, 3, 4), the cooling fan can be operated.
Lamp (HI, LO, TAIL, FOG) output	EXTERNAL LAMPS	With a certain operation (OFF, HI ON, LO ON, TAIL ON, FOG ON), the lamp relay (Low, High, Tail, Fog) can be operated.

IPDM E/R (INTELLIGENT POWER DISTRIBUTION MODULE ENGINE ROOM)

Test name	CONSULT-II screen display	Description
Cornering lamp output	CORNERING LAMP	—
Horn output	HORN	With a certain ON-OFF operation, the horn relay can be operated.

Auto Active Test DESCRIPTION

EKS00ARC

- In auto active test mode, operation inspection can be performed when IPDM E/R sends a drive signal to the following systems:
 - Front wipers
 - Tail, parking, and license lamps
 - Front fog lamps
 - Headlamps (Hi, Lo) (Daytime light system if equipped)
 - A/C compressor (magnetic clutch)
 - Cooling fan

OPERATION PROCEDURE

1. Close hood and front door RH, and lift wiper arms away from windshield (to prevent glass damage by wiper operation).

NOTE:

When auto active test is performed with hood opened, sprinkle water on windshield beforehand.

2. Turn ignition switch OFF.
3. Turn ignition switch ON and, within 20 seconds, press front door switch LH 10 times. Then turn ignition switch OFF.
4. Turn ignition switch ON within 10 seconds after ignition switch OFF.
5. When auto active test mode is actuated, horn chirps once.
6. After a series of operations is repeated three times, auto active test is completed.

NOTE:

When auto active test mode has to be cancelled halfway, turn ignition switch OFF.

CAUTION:

Be sure to perform [BL-35, "Door Switch Check \(King Cab\)"](#) or [BL-37, "Door Switch Check \(Crew Cab\)"](#) when the auto active test cannot be performed.

INSPECTION IN AUTO ACTIVE TEST MODE

- When auto active test mode is actuated, the following six steps are repeated three times.

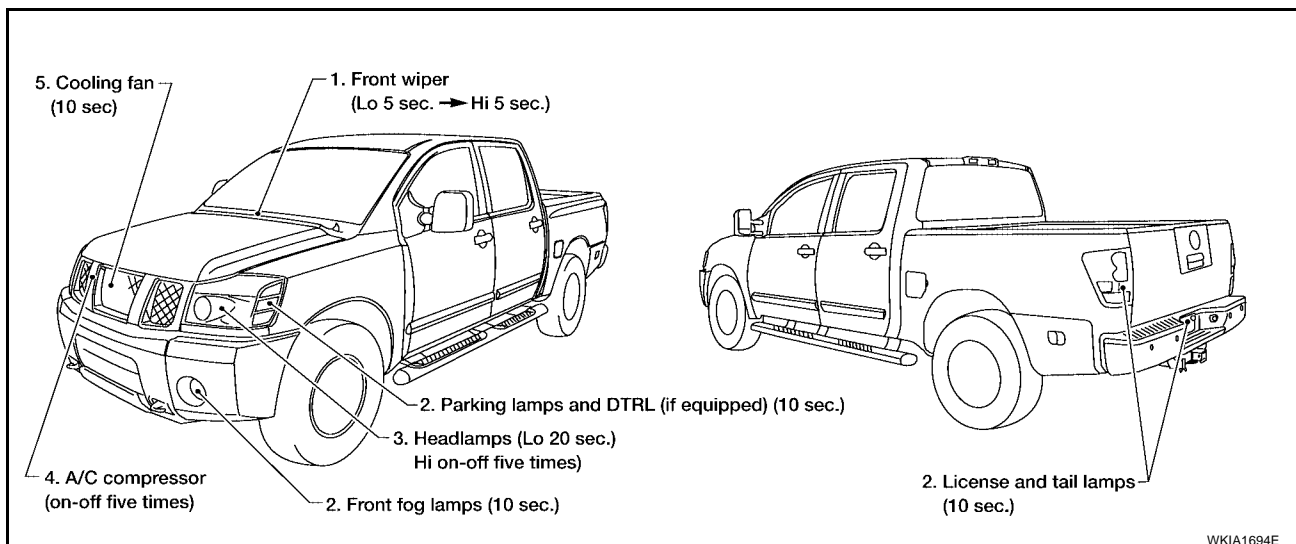

IPDM E/R (INTELLIGENT POWER DISTRIBUTION MODULE ENGINE ROOM)

Concept of Auto Active Test

- IPDM E/R actuates auto active test mode when it receives door switch signal from BCM via CAN communication line. Therefore, when auto active test mode is activated successfully, CAN communication between IPDM E/R and BCM is normal.
- If any of the systems controlled by IPDM E/R cannot be operated, possible cause can be easily diagnosed using auto active test.

Diagnosis chart in auto active test mode

Symptom	Inspection contents	Possible cause	
Any of front wipers, tail and parking lamps, front fog lamps, and head-lamps (Hi, Lo) do not operate.	Perform auto active test. Does system in question operate?	YES	● BCM signal input system
		NO	<ul style="list-style-type: none"> ● Lamp/wiper motor malfunction ● Lamp/wiper motor ground circuit malfunction ● Harness/connector malfunction between IPDM E/R and system in question ● IPDM E/R (integrated relay) malfunction
A/C compressor does not operate.	Perform auto active test. Does magnetic clutch operate?	YES	<ul style="list-style-type: none"> ● BCM signal input circuit ● CAN communication signal between BCM and ECM ● CAN communication signal between ECM and IPDM E/R
		NO	<ul style="list-style-type: none"> ● Magnetic clutch malfunction ● Harness/connector malfunction between IPDM E/R and magnetic clutch ● IPDM E/R (integrated relay) malfunction
Cooling fan does not operate.	Perform auto active test. Does cooling fan operate?	YES	<ul style="list-style-type: none"> ● ECM signal input circuit ● CAN communication signal between ECM and IPDM E/R
		NO	<ul style="list-style-type: none"> ● Cooling fan motor malfunction ● Harness/connector malfunction between IPDM E/R and cooling fan motor ● IPDM E/R (integrated relay) malfunction
Oil pressure warning lamp does not operate.	Perform auto active test. Does oil pressure warning lamp blink?	YES	<ul style="list-style-type: none"> ● Harness/connector malfunction between IPDM E/R and oil pressure switch ● Oil pressure switch malfunction ● IPDM E/R
		NO	<ul style="list-style-type: none"> ● CAN communication signal between BCM and combination meter ● Combination meter

IPDM E/R (INTELLIGENT POWER DISTRIBUTION MODULE ENGINE ROOM)

Schematic

EKS00ARD

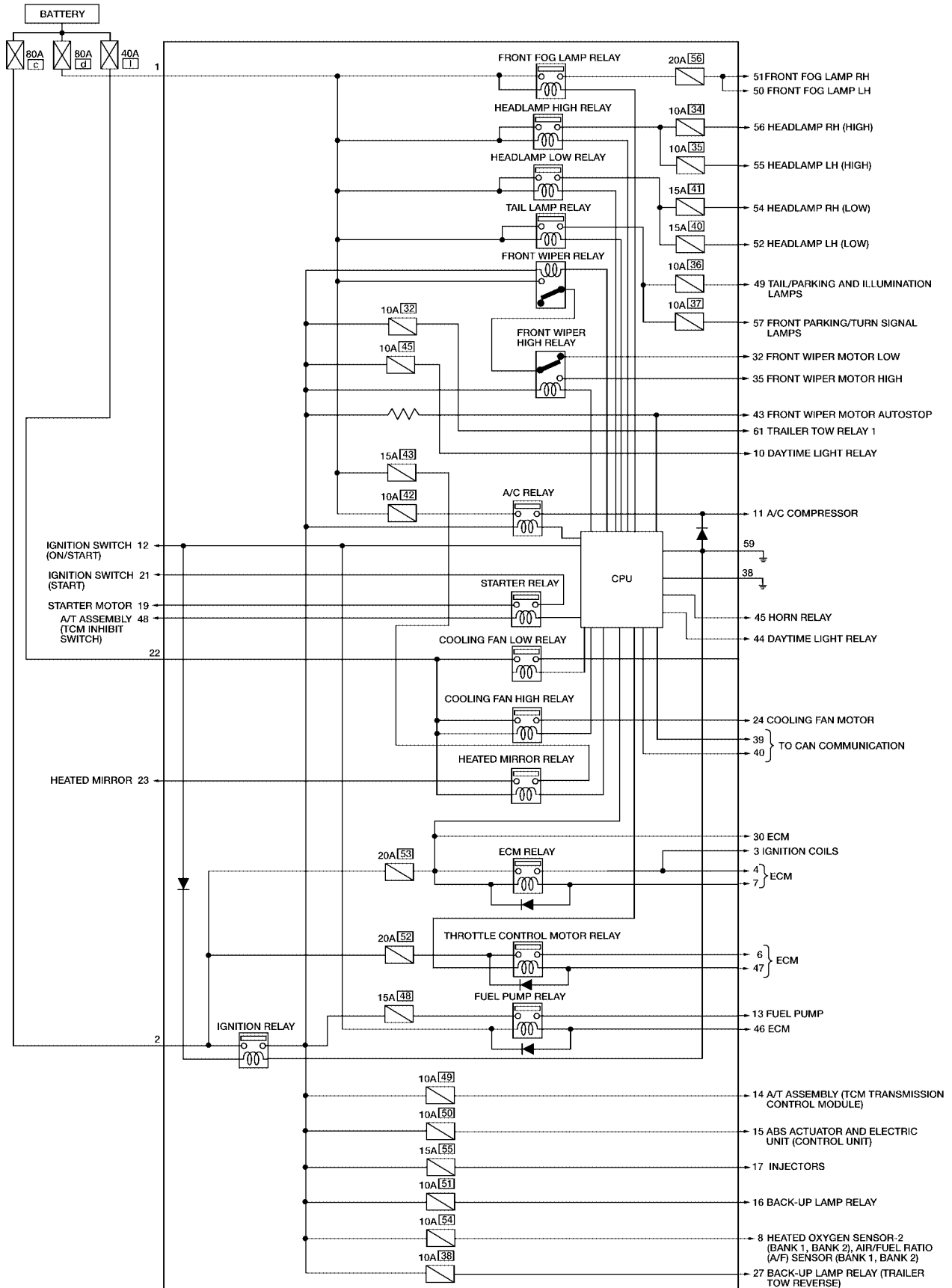

WKWA2636E

IPDM E/R (INTELLIGENT POWER DISTRIBUTION MODULE ENGINE ROOM)

IPDM E/R Terminal Arrangement

EKS00ARE

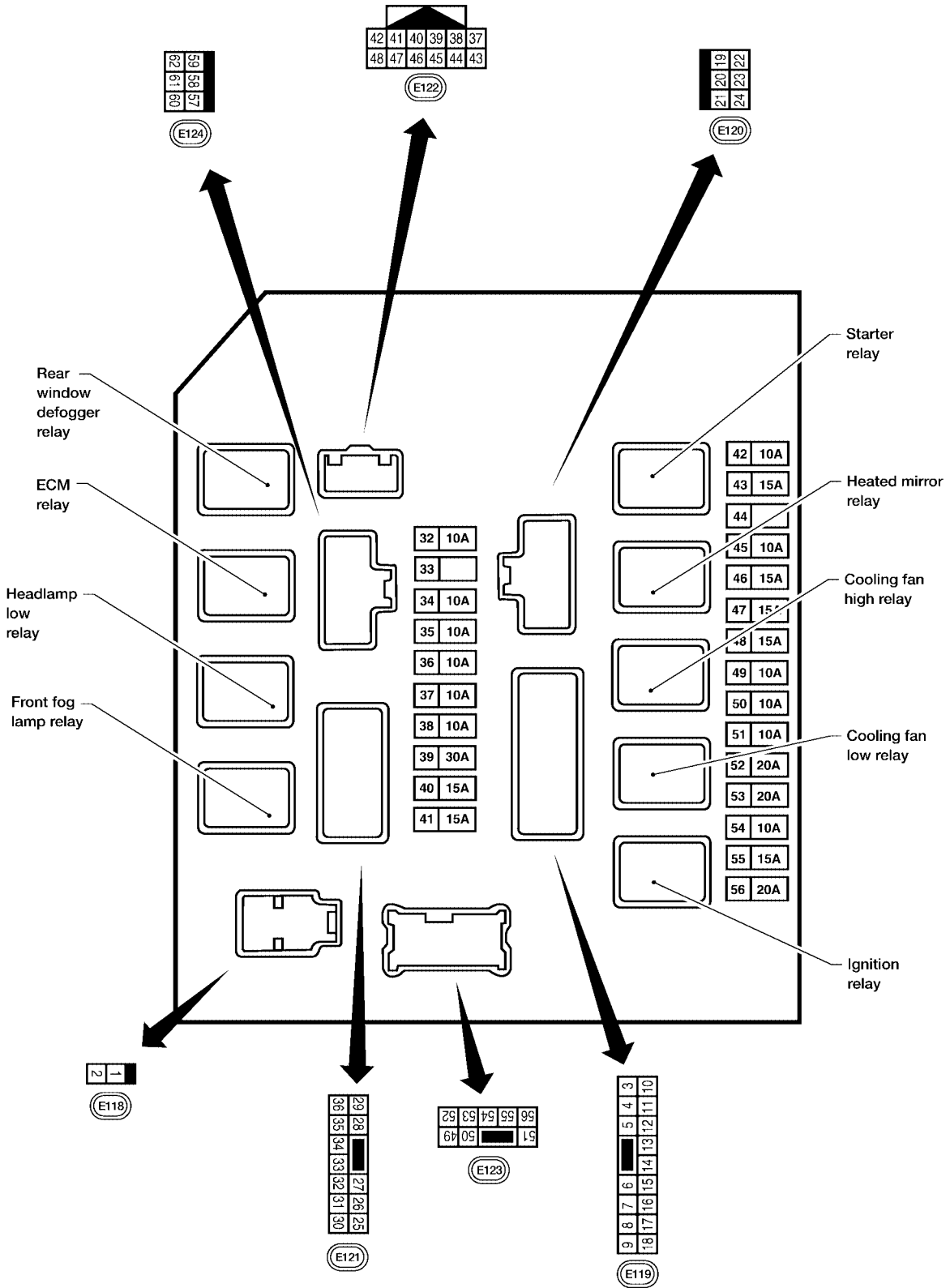

A
B
C
D
E
F
G
H
I
J
K
L
M

PG

IPDM E/R (INTELLIGENT POWER DISTRIBUTION MODULE ENGINE ROOM)

IPDM E/R Power/Ground Circuit Inspection

EKS00ARF

1. FUSE AND FUSIBLE LINK INSPECTION

- Check that the following fusible links or IPDM E/R fuses are not blown.

Terminal No.	Signal name	Fuse, fusible link No.
1, 2, 22	Battery power	a, c, d, e, l

OK or NG

- OK >> GO TO 2.
- NG >> Replace fuse or fusible link.

2. POWER CIRCUIT INSPECTION

- Disconnect IPDM E/R harness connector E118.
- Check voltage between IPDM E/R harness connector E118 terminals 1 (B/Y), 2 (R) and ground.

Battery voltage should exist.

OK or NG

- OK >> GO TO 3.
- NG >> Repair or replace IPDM E/R power circuit harness.

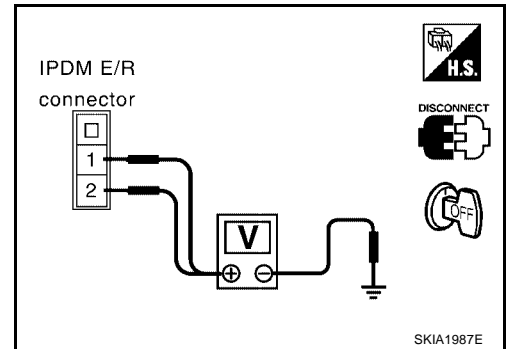

3. GROUND CIRCUIT INSPECTION

- Disconnect IPDM E/R harness connectors E122 and E124.
- Check continuity between IPDM E/R harness connector E122 terminal 38 (B), and E124 terminal 59 (B) and ground.

Continuity should exist.

OK or NG

- OK >> Inspection End.
- NG >> Repair or replace ground circuit harness of IPDM E/R.

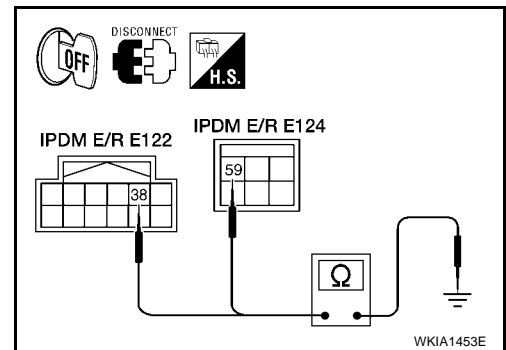

IPDM E/R (INTELLIGENT POWER DISTRIBUTION MODULE ENGINE ROOM)

EKS00ARG

Inspection with CONSULT-II (Self-Diagnosis)

CAUTION:

If a CONSULT-II is used with no connection of CONSULT-II CONVERTER, malfunctions might be detected in self-diagnosis depending on which control unit(s) carry out CAN communication.

1. SELF-DIAGNOSIS RESULT CHECK

1. Connect CONSULT-II and select "IPDM E/R" on the Diagnosis System Selection screen.
2. Select "SELF-DIAG RESULTS" on the diagnosis mode selection screen.
3. Check display content in self-diagnosis results.

CONSULT-II Display	CONSULT-II display code	TIME		Details of diagnosis result
		CRNT	PAST	
NO DTC IS DETECTED. FURTHER TESTING MAY BE REQUIRED.	—	—	—	No malfunction
CAN COMM CIRC	U1000	X	X	Any of items listed below have errors: <ul style="list-style-type: none">● TRANSMIT DIAG● ECM● BCM/SEC

NOTE:

The Details for Display for the Period are as follows:

- CRNT: Error currently detected by IPDM E/R.
- PAST: Error detected in the past and stored in IPDM E/R memory.

Contents displayed

NO DTC DETECTED. FURTHER TESTING MAY BE REQUIRED.>>INSPECTION END.

CAN COMM CIRC>>Print out the self-diagnosis result and refer to [LAN-7, "CAN COMMUNICATION"](#) .

A
B
C
D
E
F
G
H
I
J
L
M

IPDM E/R (INTELLIGENT POWER DISTRIBUTION MODULE ENGINE ROOM)

EKS00ARH

Removal and Installation of IPDM E/R

REMOVAL

1. Disconnect negative battery cable.
2. Remove IPDM E/R upper cover.

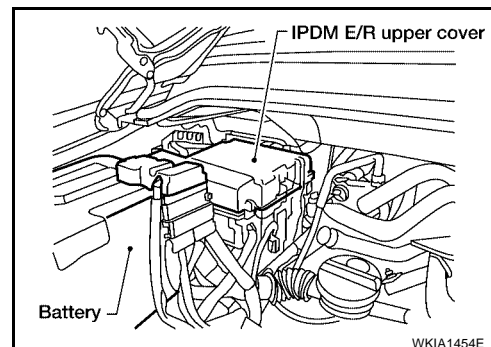

3. Release 2 clips and pull IPDM E/R up from case.
4. Disconnect IPDM E/R connectors and remove the IPDM E/R.

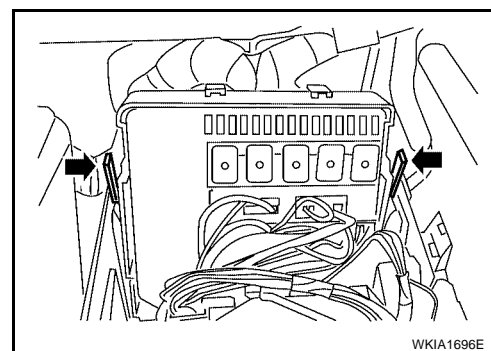

INSTALLATION

Installation is in the reverse order of removal.

GROUND CIRCUIT

PF24080

EKS00ARI

GROUND CIRCUIT Ground Distribution MAIN HARNESS

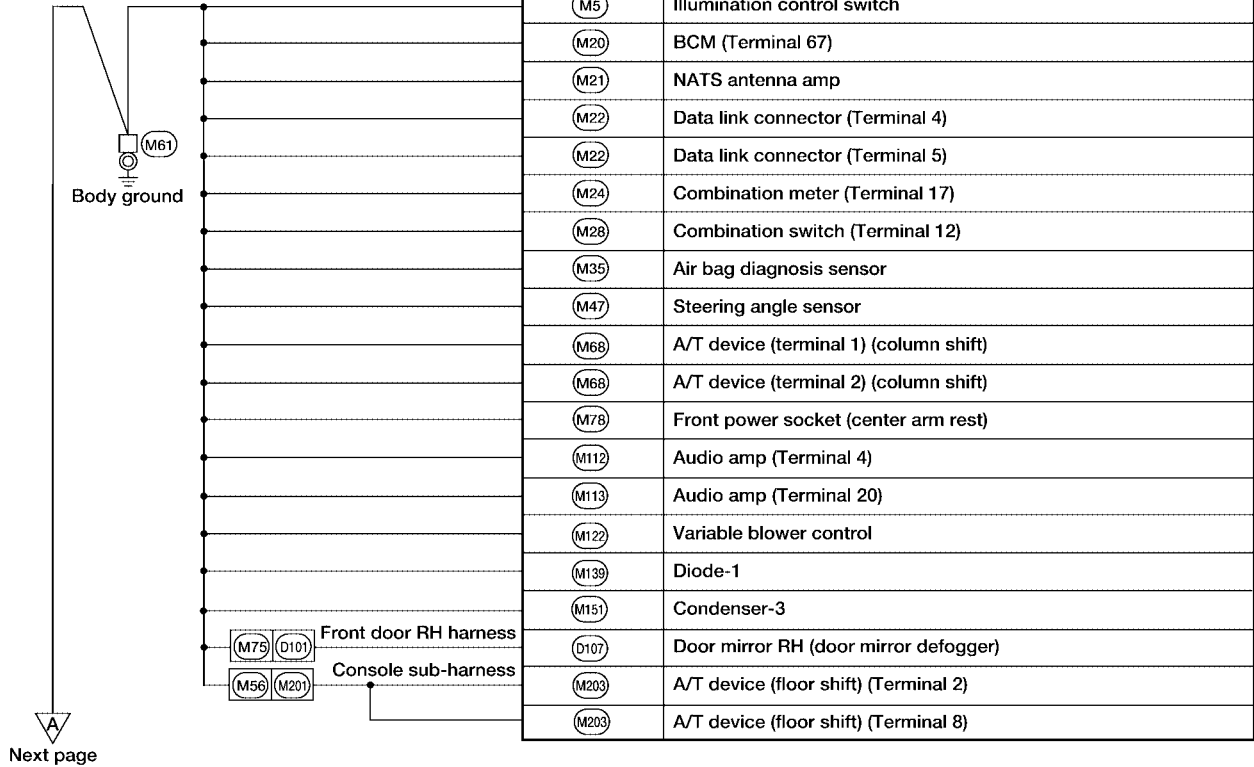
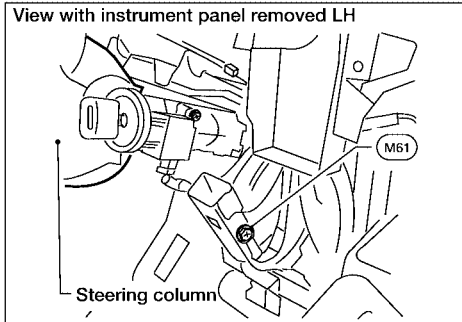

A
B
C
D
E
F
G
H
I
J
L
M

PG

WKIA3628E

GROUND CIRCUIT

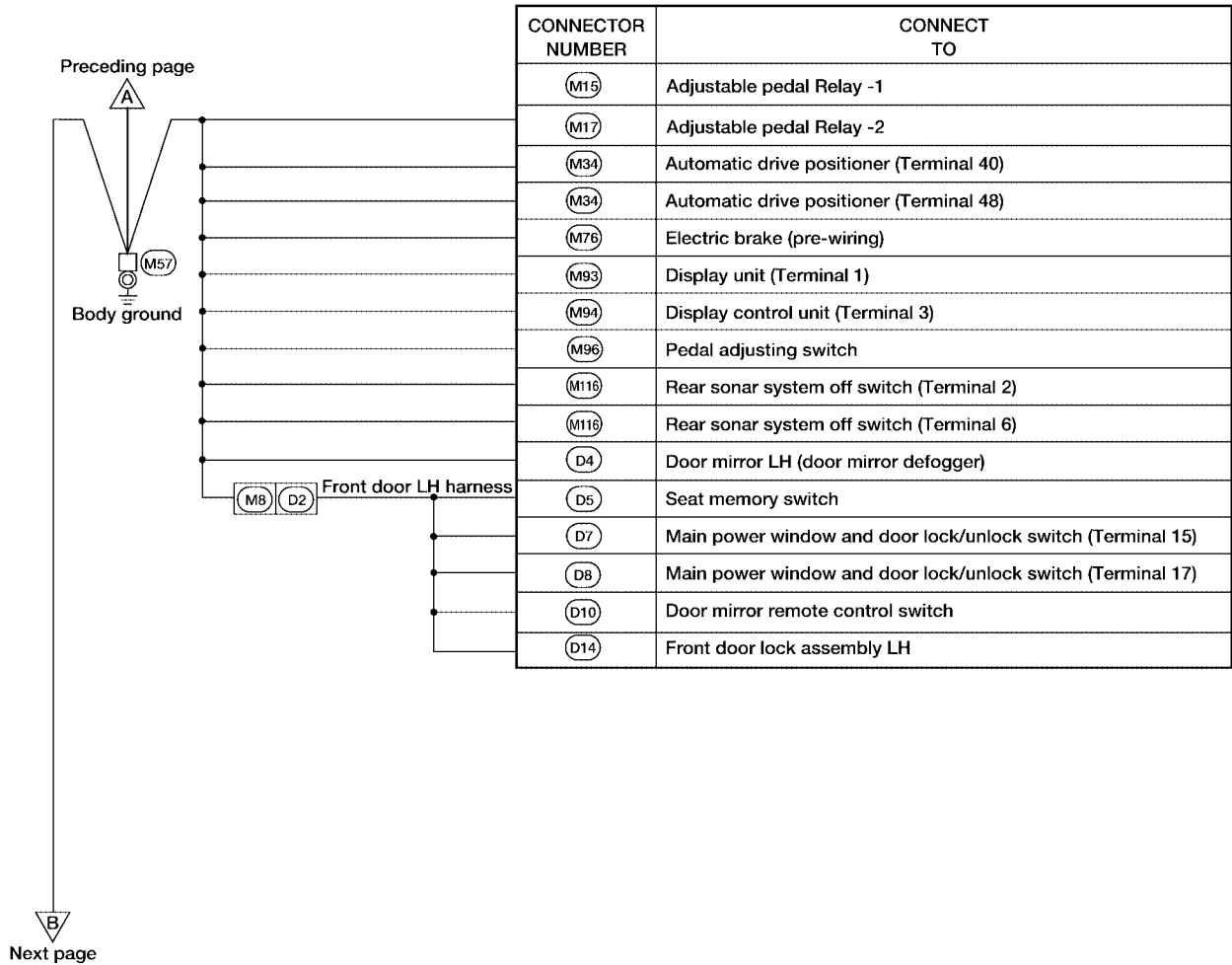
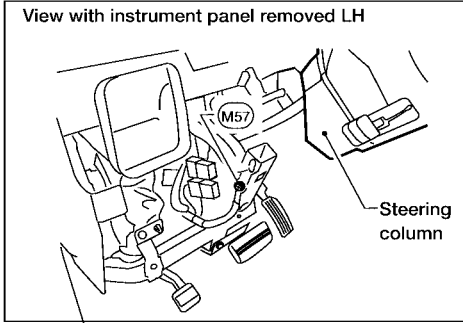

WKIA3629E

GROUND CIRCUIT

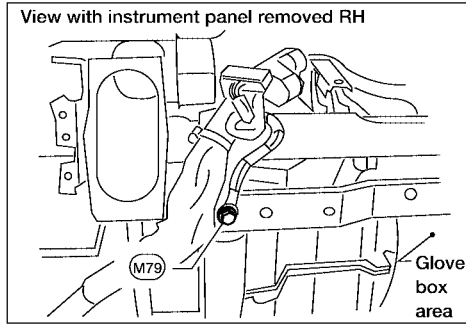

Preceding page

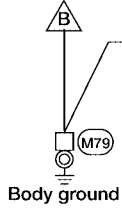

CONNECTOR NUMBER	CONNECT TO
(M3)	Fuse block J/B
(M6)	VDC off switch (column shift)
(M13)	Front passenger air bag off indicator
(M49)	Front air control (Terminal 1)
(M53)	Front power socket LH
(M54)	Front power socket RH (for cigarette lighter)
(M55)	Hazard switch
(M59)	Glove box lamp
(M67)	Tow mode switch (column shift) (Terminal 2)
(M67)	Tow mode switch (column shift) (Terminal 6)
(M81)	Shift lock control unit
(M98)	AV switch
(M107)	Front blower motor relay
(M148)	VDC OFF switch (floor shift)
(R3)	Vanity lamp LH
(R7)	Auto anti-dazzling inside mirror
(R8)	Vanity lamp RH
(R102)	Front room/map lamp assembly
(R105)	Compass and thermometer
(R106)	HOMELINK universal transceiver
(R4)	Sunroof motor
(D105)	Power window and door lock/unlock switch RH
(M206)	DVD player (Terminal 22)
(M207)	Console power socket
(M252)	Front heated seat switch RH
(M255)	Front heated seat switch LH

A
B
C
D
E
F
G
H
I
J
L
M

PG

WKIA3631E

GROUND CIRCUIT

ENGINE ROOM HARNESS

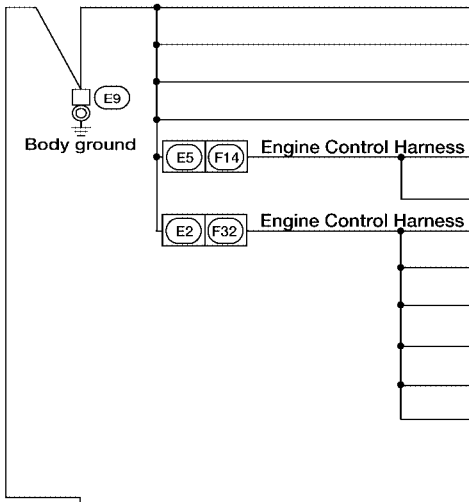
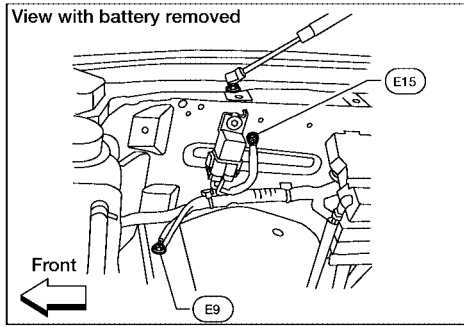

CONNECTOR NUMBER	CONNECT TO
(E16)	ECM (Terminal 115)
(E16)	ECM (Terminal 116)
(E142)	Transfer control unit (Terminal 6)
(E142)	Transfer control unit (Terminal 18)
(F102)	Knock sensor (bank 1) shield
(F104)	Knock sensor (bank 2) shield
(F9)	A/T assembly (TCM) (Terminal 10)
(F9)	A/T assembly (TCM) (Terminal 5)
(F11)	Crankshaft position sensor (POS)
(F23)	Camshaft position sensor (PHASE)
(F50)	Electric throttle control actuator (throttle position sensor shield)
(F54)	ECM (Terminal 1)

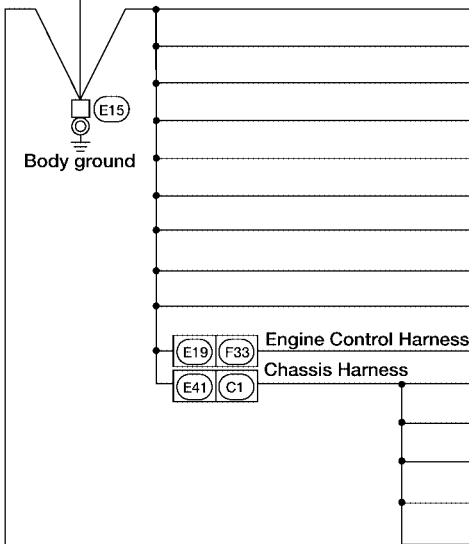

CONNECTOR NUMBER	CONNECT TO
(E3)	Horn
(E11)	Front combination lamp LH (headlamp) (terminal 3)
(E11)	Front combination lamp LH (headlamp) (terminal 4)
(E21)	Brake fluid level switch
(E102)	Front fog lamp RH
(E103)	Daytime light relay
(E106)	Washer fluid level switch
(E113)	Cooling fan motor
(E116)	Condenser-2
(F68)	Water valve
(C5)	Fuel level sensor unit and fuel pump (fuel pump)
(C12)	License plate lamp
(C13)	Rear combination lamp LH
(C14)	Rear combination lamp RH
(C16)	Differential lock position switch

Next page

WKIA3632E

GROUND CIRCUIT

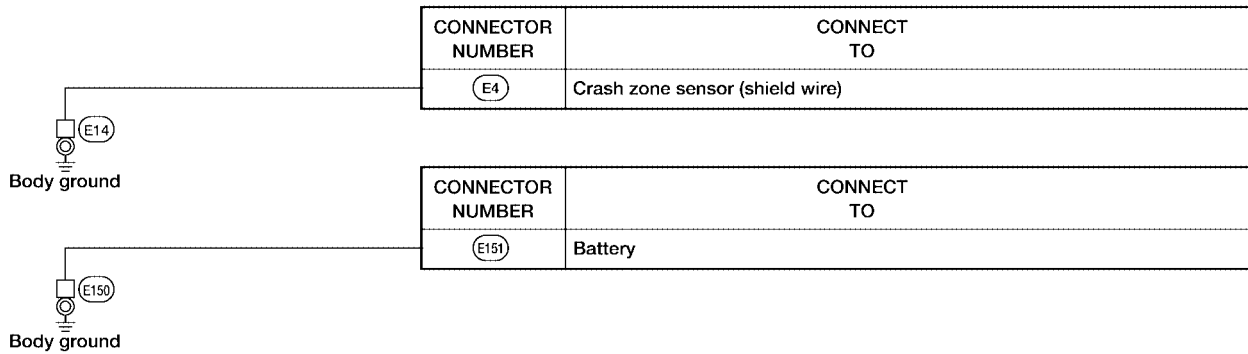
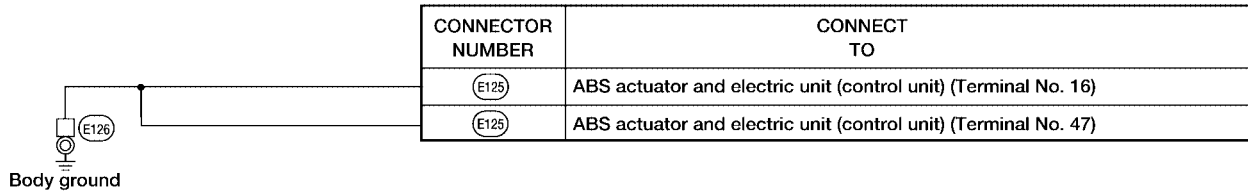
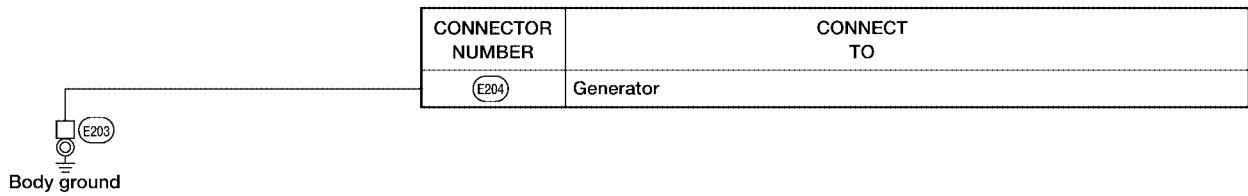
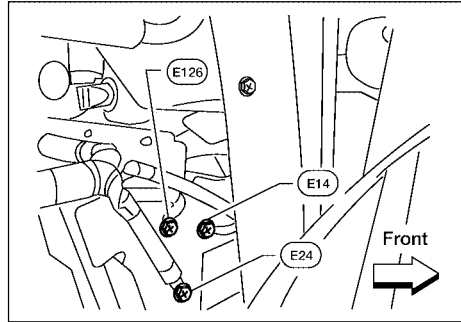
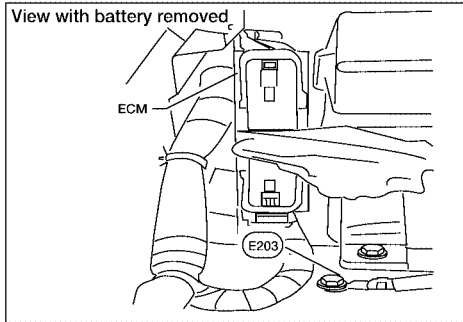

WKIA3634E

A
B
C
D
E
F
G
H
I
J
PG
L
M

GROUND CIRCUIT

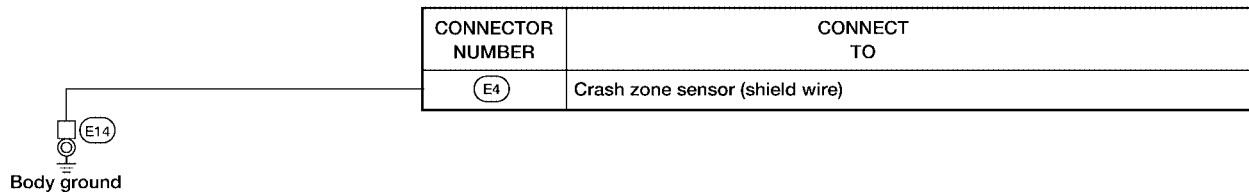
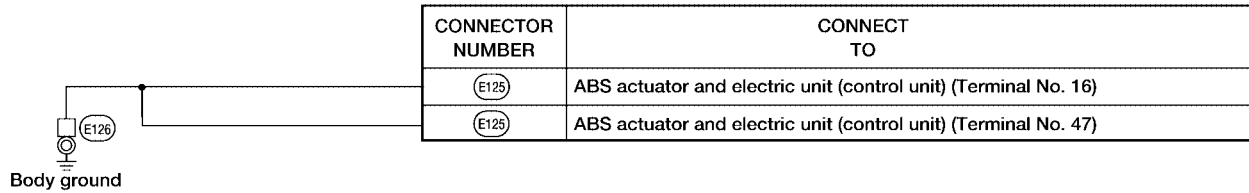
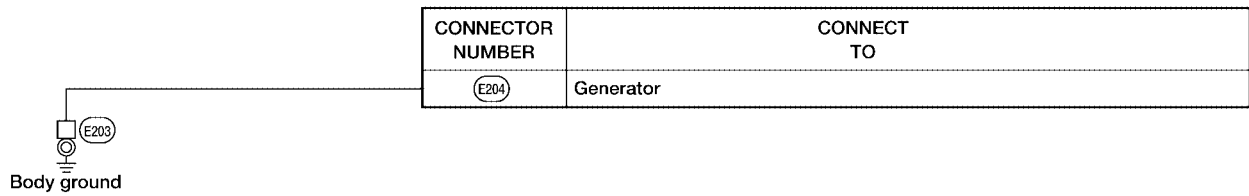
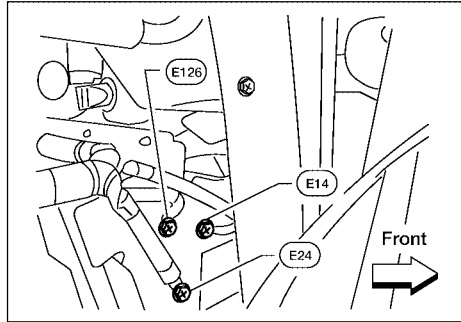
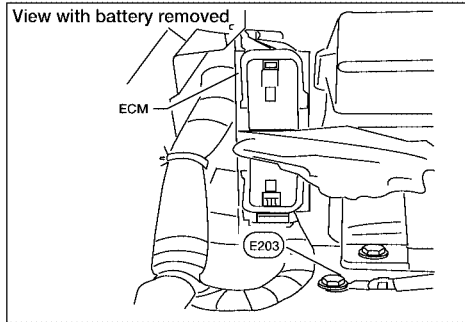

WKIA1459E

GROUND CIRCUIT

ENGINE CONTROL HARNESS

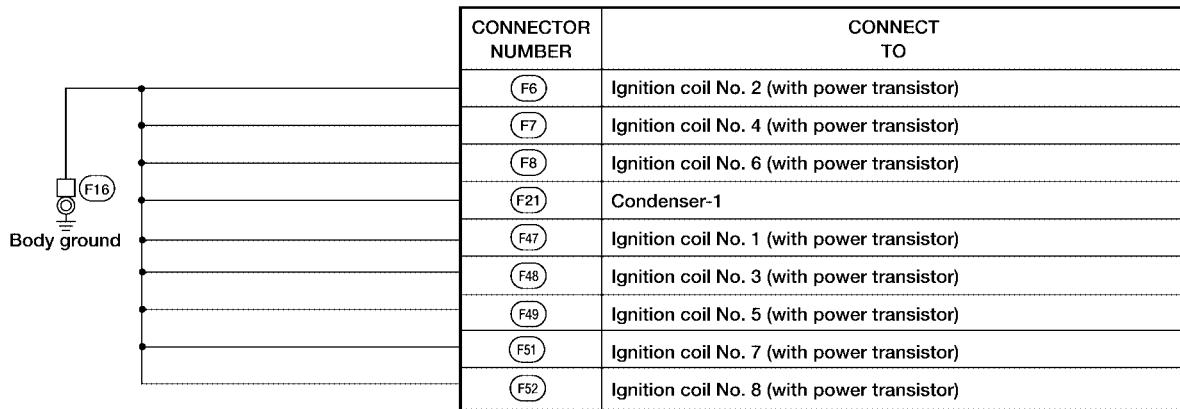
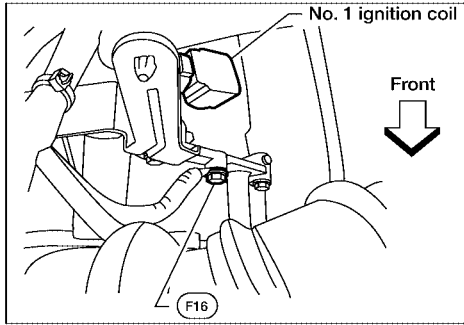

A
B
C
D
E
F
G
H
I
J
L
M

PG

WKIA1460E

GROUND CIRCUIT

BODY HARNESS

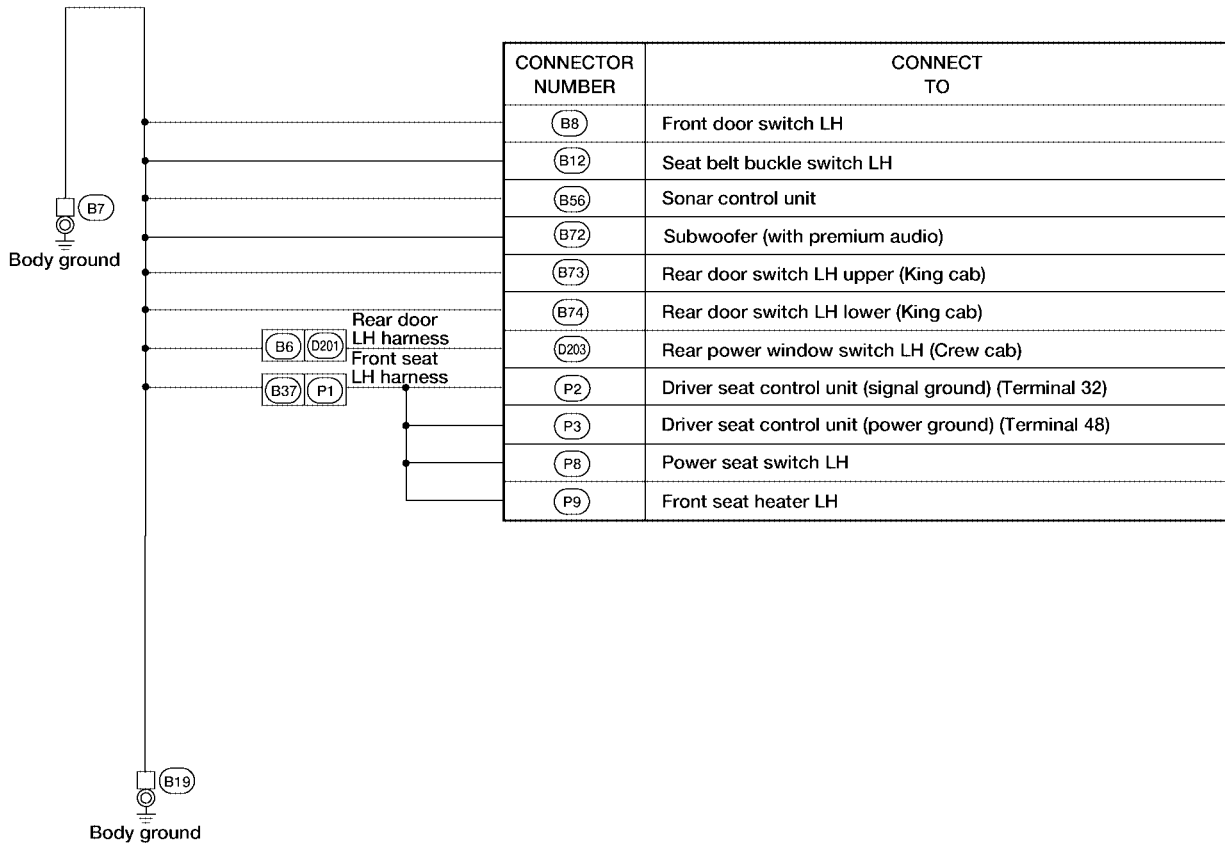
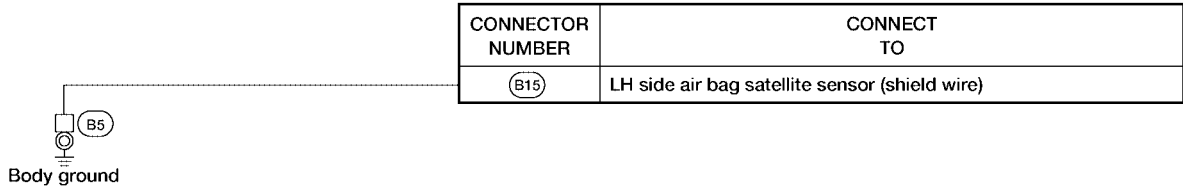
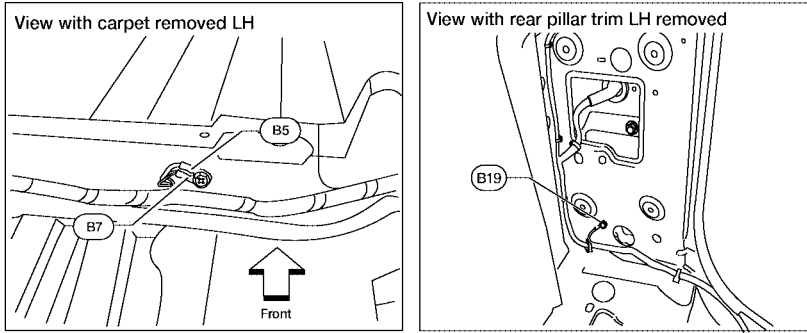

WKIA2850E

GROUND CIRCUIT

BODY NO. 2 HARNESS

A
B
C
D
E
F
G
H
I
J
PG
L
M

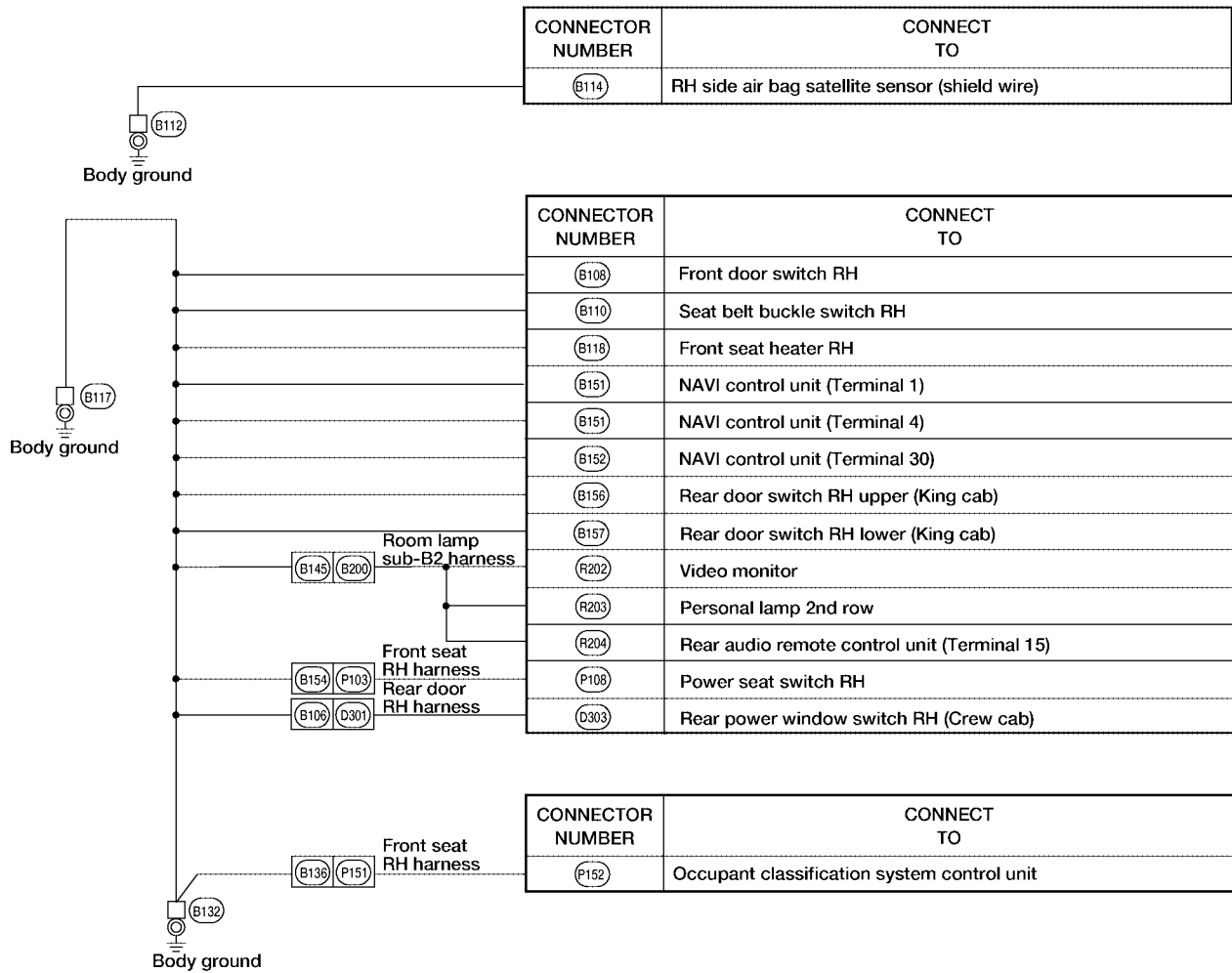
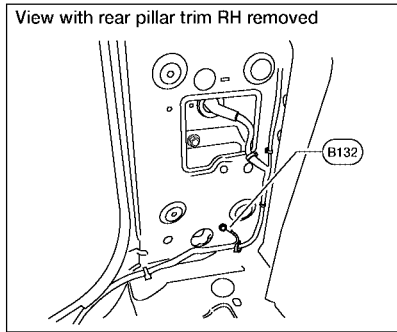
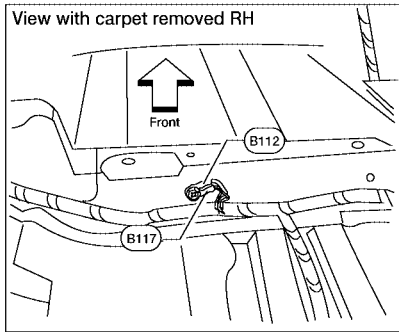

WKIA2851E

HARNESS

Harness Layout

EKS00ARJ

HOW TO READ HARNESS LAYOUT

The following Harness Layouts use a map style grid to help locate connectors on the drawings:

- Main Harness
- Engine Room Harness LH View (Engine Compartment)
- Engine Room Harness RH View (Engine Compartment)
- Engine Control Harness
- Body Harness and Rear Bumper Sub Harness
- Body No. 2 Harness and Fuel Pump Sub Harness





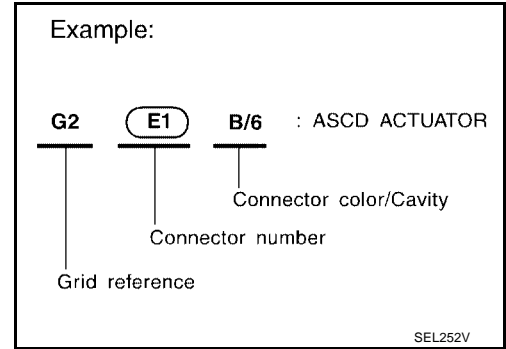







To use the grid reference

1. Find the desired connector number on the connector list.
2. Find the grid reference.
3. On the drawing, find the crossing of the grid reference letter column and number row.
4. Find the connector number in the crossing zone.
5. Follow the line (if used) to the connector.



CONNECTOR SYMBOL

Main symbols of connector (in Harness Layout) are indicated below.

Connector type	Water proof type		Standard type	
	Male	Female	Male	Female
<ul style="list-style-type: none"> ● Cavity: Less than 4 ● Relay connector 				
<ul style="list-style-type: none"> ● Cavity: From 5 to 8 				
<ul style="list-style-type: none"> ● Cavity: More than 9 				
<ul style="list-style-type: none"> ● Ground terminal etc. 	—			

HARNESS

OUTLINE (KING CAB MODELS)

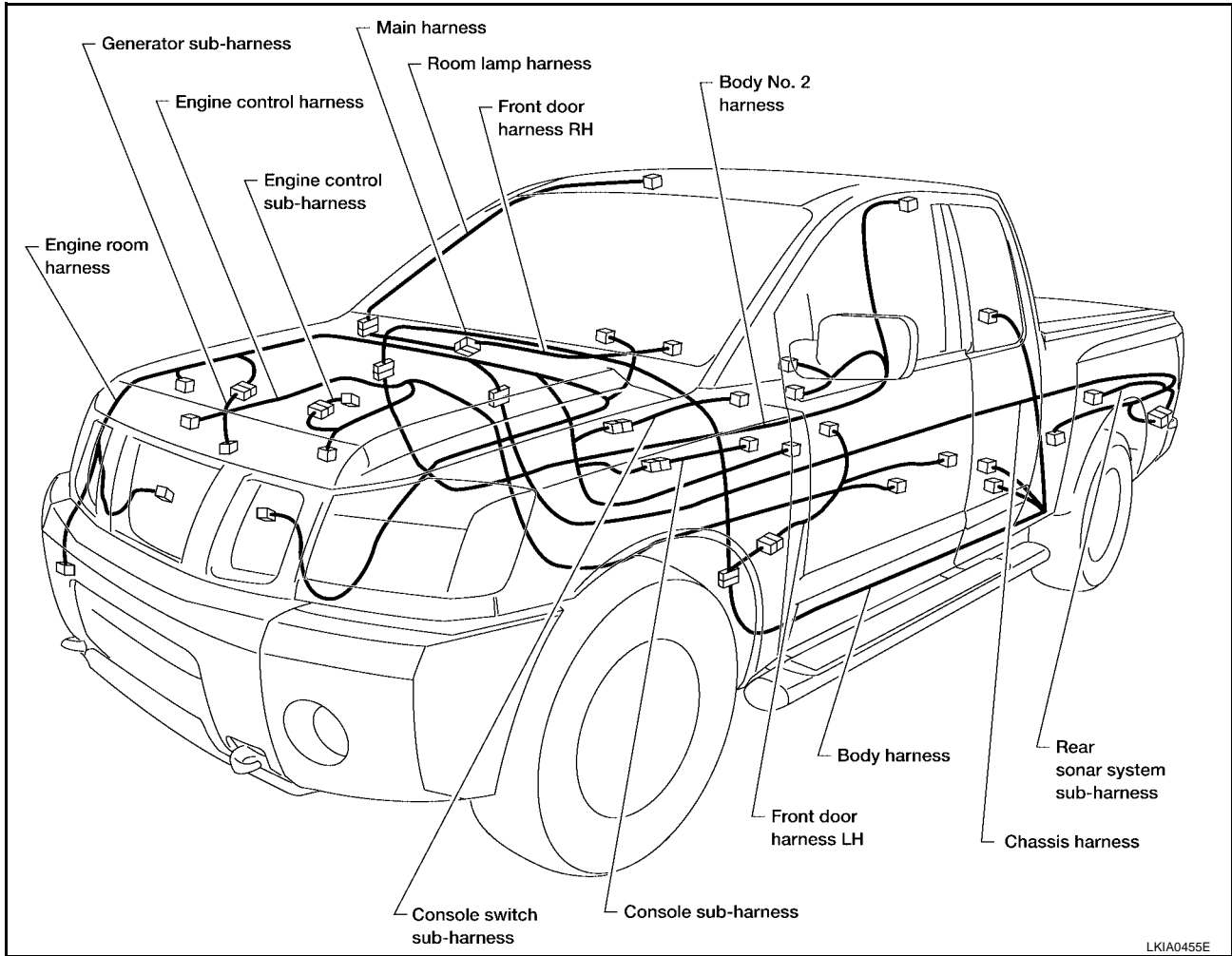

A
B
C
D
E
F
G
H
I
J

PG

L

M

HARNESS

OUTLINE (CREW CAB MODELS)

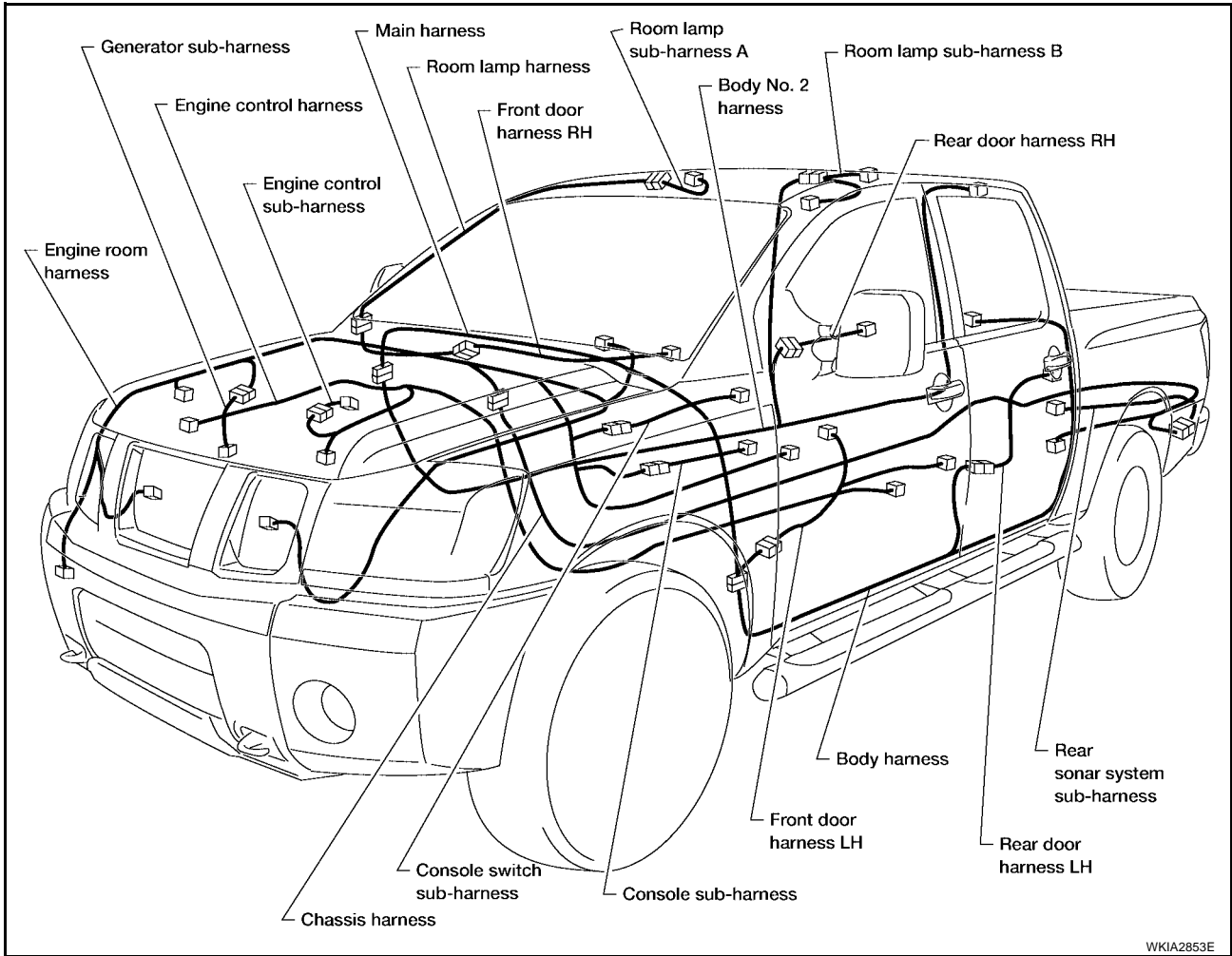

HARNESS

MAIN HARNESS

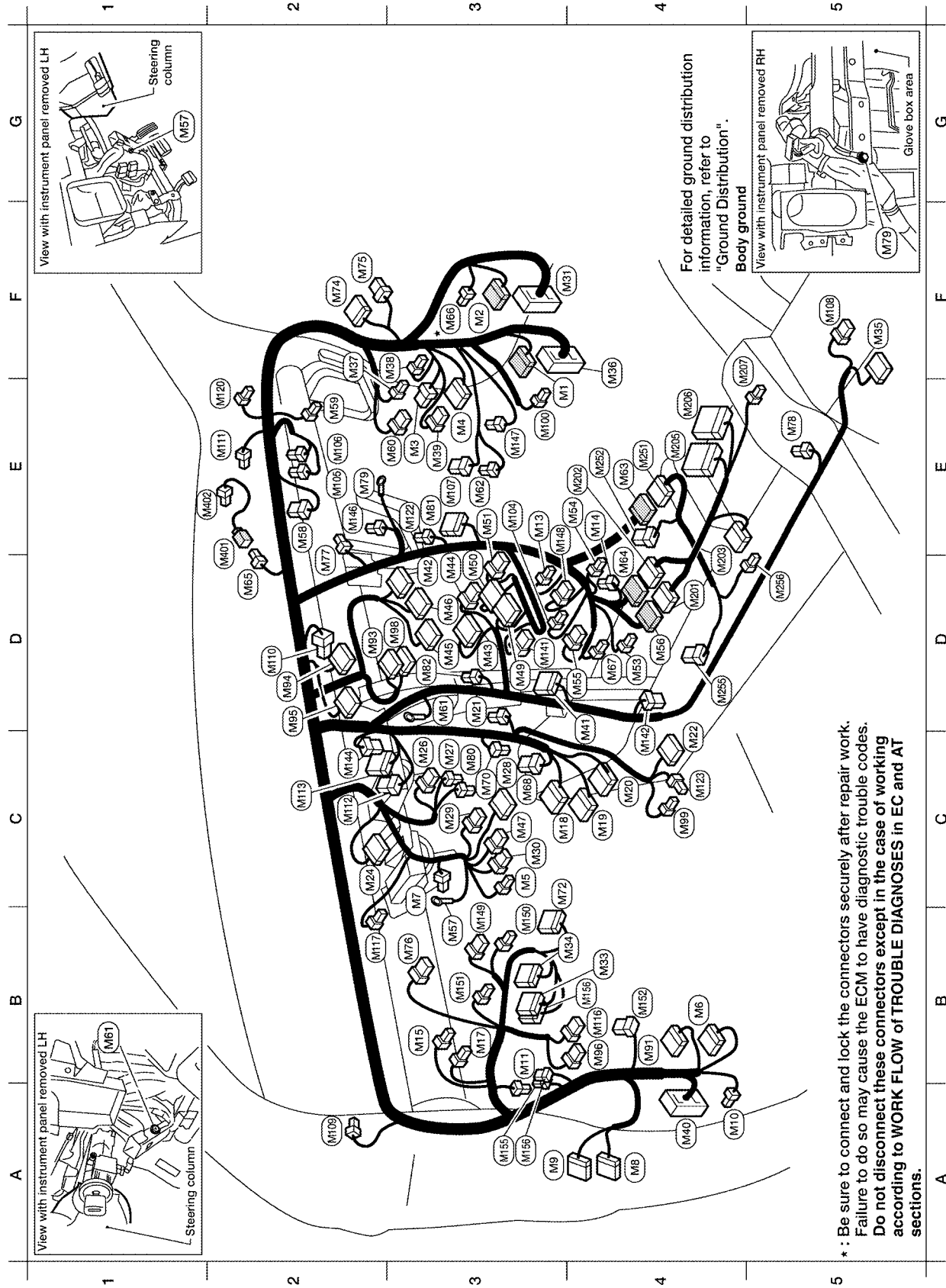

* : Be sure to connect and lock the connectors securely after repair work. Failure to do so may cause the ECM to have diagnostic trouble codes. Do not disconnect these connectors except in the case of working according to WORK FLOW of TROUBLE DIAGNOSES in EC and AT sections.

WKIA3700E

HARNESSES

E4 (M1)	W/16 : To (R1)	C3 (M47)	W/8 : Steering angle sensor	E3 (M107)	B/5 : Front blower motor relay
F3 (M2)	W/12 : To (R2) (with sunroof)	D3 (M49)	B/26 : Front air control	F5 (M108)	B/6 : Yaw rate/side decel G-sensor (VDC)
E3 (M3)	W/8 : Fuse block (J/B)	D3 (M50)	W/18 : Front air control	A2 (M109)	BR/2 : Front tweeter LH
E3 (M4)	W/16 : Fuse block (J/B)	D4 (M53)	B/2 : Front power socket LH	D2 (M110)	BR/2 : Center speaker (with premium audio)
C3 (M5)	W/3 : Illumination control switch	E3 (M54)	B/2 : Front power socket RH	E2 (M111)	BR/2 : Front tweeter RH
B4 (M6)	W/10 : To (E10)		(for cigarette lighter)	C2 (M112)	W/8 : Audio amplifier (with premium audio)
B3 (M7)	L/5 : Water valve relay	D4 (M55)	W/8 : Hazard switch	C2 (M113)	L/24 : Audio amplifier (with premium audio)
A4 (M8)	W/16 : To (D2)	D4 (M56)	W/16 : To (M20) (floor shift)	B4 (M116)	GR/8 : Rear sonar system OFF switch
A4 (M9)	BR/24 : To (D1)	B3 (M57)	- : Body ground	B2 (M117)	B/2 : Sonar buzzer
A4 (M10)	To (E29)	E2 (M58)	B/6 : Intake door motor	E2 (M120)	W/4 : Remote keyless entry receiver
B3 (M11)	B/1 : Parking brake switch	E2 (M59)	BR/2 : Glove box lamp	E3 (M122)	W/4 : Variable blower control
E3 (M13)	W/3 : Front passenger air bag off indicator	E3 (M60)	W/6 : Fuse block (J/B)	C4 (M123)	W/2 : Tire pressure warning check connector
E4 (M14)	W/2 : Front power socket (center arm rest)	D3 (M61)	- : Body ground	D3 (M141)	W/8 : 4WD shift switch
B3 (M15)	B/5 : Adjustable pedal relay 1	E3 (M62)	B/2 : Front blower motor	C4 (M142)	B/6 : Mode door motor
B3 (M17)	B/5 : Adjustable pedal relay 2	D2 (M65)	W/4 : To (M401)	C2 (M144)	B/6 : Defroster door motor
C3 (M18)	W/40 : BCM (body control module)	F3 (M66)	B/1 : To (E33)	E2 (M146)	W/2 : Intake sensor
C4 (M19)	W/15 : BCM (body control module)	D4 (M67)	GR/8 : Tow mode switch (column shift)	E3 (M147)	B/6 : Air mix door motor (front)
C4 (M20)	B/15 : BCM (body control module)	C3 (M68)	W/8 : A/T device (column shift)	D3 (M148)	GR/6 : VDC OFF switch
D3 (M21)	W/4 : NATS antenna amplifier	C3 (M70)	W/2 : Condenser-3	B3 (M149)	W/6 : Cargo lamp switch
C4 (M22)	W/16 : Data link connector	C4 (M72)	W/6 : Differential lock mode switch	B3 (M150)	L/4 : Cargo lamp relay
D3 (M23)	W/2 : Diode-1	F2 (M74)	BR/20 : To (J102)	B3 (M151)	W/2 : Condenser-3
C2 (M24)	W/40 : Combination meter	F2 (M75)	W/8 : To (J101)	B4 (M152)	L/5 : Rear window defogger cut-off relay
C3 (M26)	W/6 : Ignition switch	B3 (M76)	W/6 : Electric brake (pre-wiring)	Console sub-harness (floor shift)	
C3 (M27)	W/4 : Key switch/key lock sol (floor shift)	D2 (M77)	Y/4 : Front pass air bag module (service replacement)	B4 (M154)	B/5 : Rear power drop glass up relay
C3 (M28)	W/16 : Combination switch			A3 (M155)	B/5 : Rear power drop glass down relay
C3 (M29)	Y/6 : Combination switch (spiral cable)	E5 (M78)	W/2 : Armrest power socket (bench seat)	A3 (M156)	W/6 : Rear power drop glass down relay
C3 (M30)	GR/8 : Combination switch (spiral cable)	E2 (M79)	- : Body ground	D4 (M201)	W/16 : To (M55)
F4 (M31)	SMJ : To (E19)	C3 (M80)	W/2 : Key switch (column shift)	E4 (M202)	BR/24 : To (M64)
B4 (M33)	W/32 : Automatic drive positioner control unit	E3 (M81)	GR/10 : Shift lock control unit (floor shift)	D4 (M203)	W/12 : A/T device
B4 (M34)	W/16 : Automatic drive positioner control unit	D3 (M82)	W/2 : Circuit breaker -2	E4 (M205)	GR/16 : DVD player
F5 (M35)	Y/28 : Air bag diagnosis sensor unit	B4 (M81)	W/16 : To (E26)	E4 (M206)	L/16 : DVD player
F4 (M36)	SMJ : To (E19)	D2 (M83)	W/24 : Display unit (with NAVI)	F5 (M207)	B/2 : Console power socket
E2 (M37)	B/1 : Fuse block (J/B)	D2 (M84)	W/24 : Display control unit (with NAVI)	Console switch sub-harness (floor shift)	
E3 (M38)	B/2 : Fuse block (J/B)	D2 (M85)	W/32 : Display control unit (with NAVI)	E4 (M251)	BR/20 : To (M85)
E3 (M39)	W/8 : Fuse block (J/B)	B4 (M86)	BR/6 : Pedal adjusting switch	E4 (M252)	BR/6 : Heated seat switch (passenger)
A4 (M40)	SMJ : To (B69)	D3 (M88)	W/24 : AV switch	D4 (M253)	BR/6 : Heated seat switch (driver)
C4 (M41)	W/16 : Satellite radio tuner (pre-wiring)	C4 (M89)	BR/2 : Foot lamp LH	D5 (M256)	B/2 : A/T device illumination
D3 (M42)	W/12 : Audio unit	E3 (M100)	BR/2 : Foot lamp RH	Optical sensor sub-harness	
D3 (M43)	W/10 : Audio unit	E3 (M104)	W/4 : Auxiliary in jack (audio)	D2 (M401)	W/4 : To (M65)
D3 (M44)	W/6 : Audio unit	E2 (M105)	Y/2 : Front passenger air bag module	E2 (M402)	B/4 : Optical sensor
D3 (M45)	W/16 : Audio unit	E2 (M106)	O/2 : Front passenger air bag module	* : Refer to previous page	
D3 (M46)	W/20 : Audio unit				

HARNESS

ENGINE ROOM HARNESS (LH VIEW)

Engine Compartment

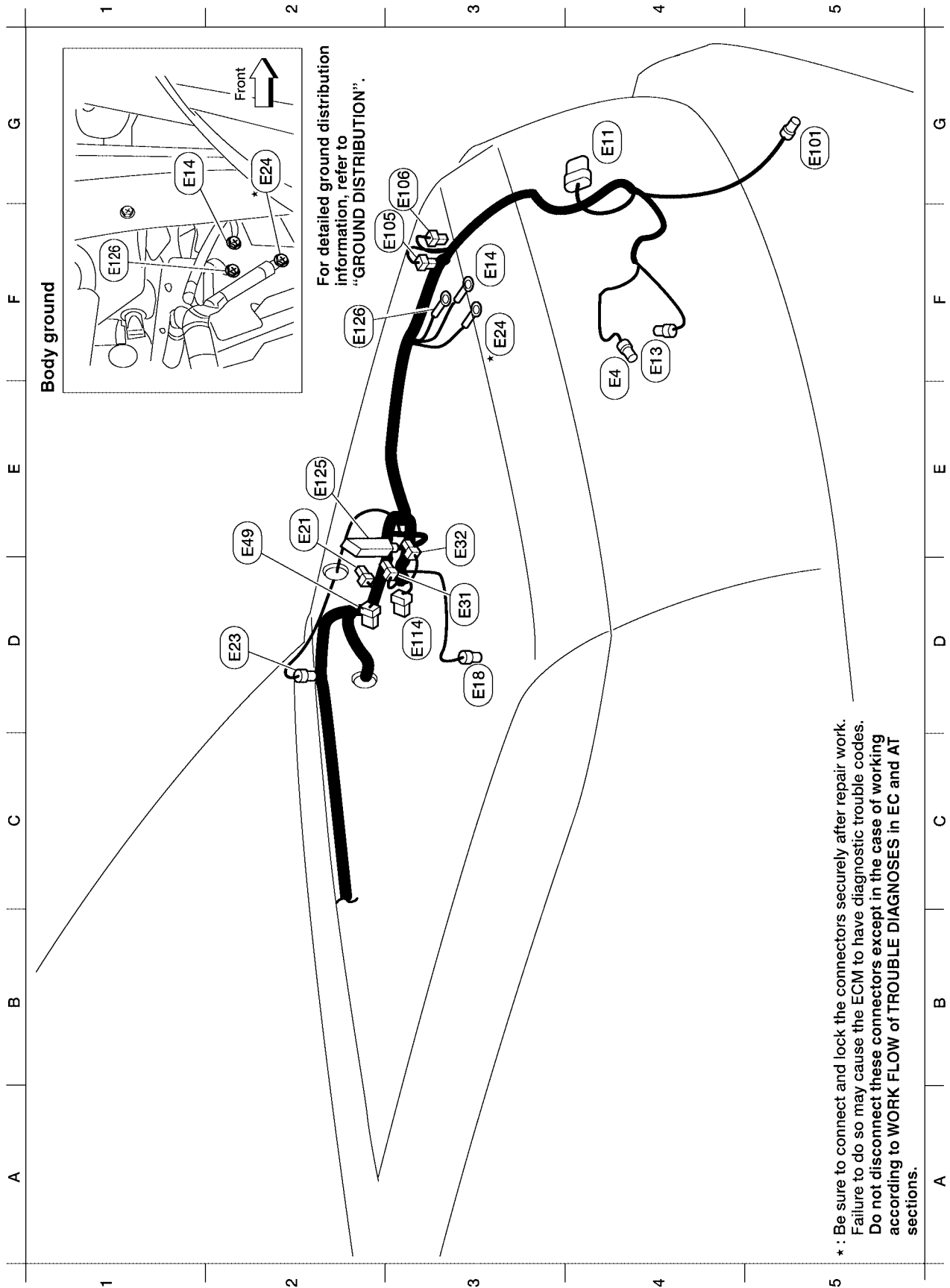

Refer to [PG-46, "ENGINE ROOM HARNESS \(RH VIEW\)"](#) for continuation of engine room harness.

A
B
C
D
E
F
G
H
I
J
K
L
M

PG

HARNESS

E4	(E4)	Y/2	: Crash zone sensor
G4	(E11)	B/6	: Front combination lamp LH
F4	(E13)	GR/2	: Ambient sensor 2
F3	(E14)	-	: Body ground
D3	(E18)	GR/2	: Front wheel sensor LH
E2	(E21)	GR/2	: Brake fluid level switch
D2	(E23)	GR/6	: Front wiper motor
F3	(E24)	*	: Body ground
D3	(E31)	B/3	: Front pressure sensor
E3	(E32)	B/3	: Rear pressure sensor
E2	(E49)	B/6	: Active booster
G5	(E101)	B/2	: Front fog lamp LH
F3	(E105)	GR/2	: Washer motor
G3	(E106)	BR/2	: Washer fluid level switch
D3	(E114)	B/6	: Delta stroke sensor
E2	(E125)	B/47	: ABS actuator and electric unit (control unit)
F2	(E126)	-	: Body ground

* : Be sure to connect and lock the connectors securely after repair work. Failure to do so may cause the ECM to have diagnostic trouble codes.
Do not disconnect these connectors except in the case of working according to WORK FLOW of TROUBLE DIAGNOSES in EC and AT sections.

HARNESS

Passenger Compartment

- (E10) W/10 : To (M6)
- * (E20) B/8 : Accelerator pedal position (APP) sensor
- (E26) W/16 : To (M91)
- (E29) Y/4 : To (MT10)
- (E34) W/24 : To (B40)
- (E35) W/12 : To (B41)
- (E36) W/2 : To (B42)
- * (E37) BR/2 : ASCD brake switch
- * (E38) W/4 : Stop lamp switch (column shift)
- * (E39) B/2 : Stop lamp switch (floor shift)
- (E50) BR/2 : To (B75)
- (E109) GR/2 : Pedal adjusting motor
- (E110) W/3 : Pedal adjusting motor

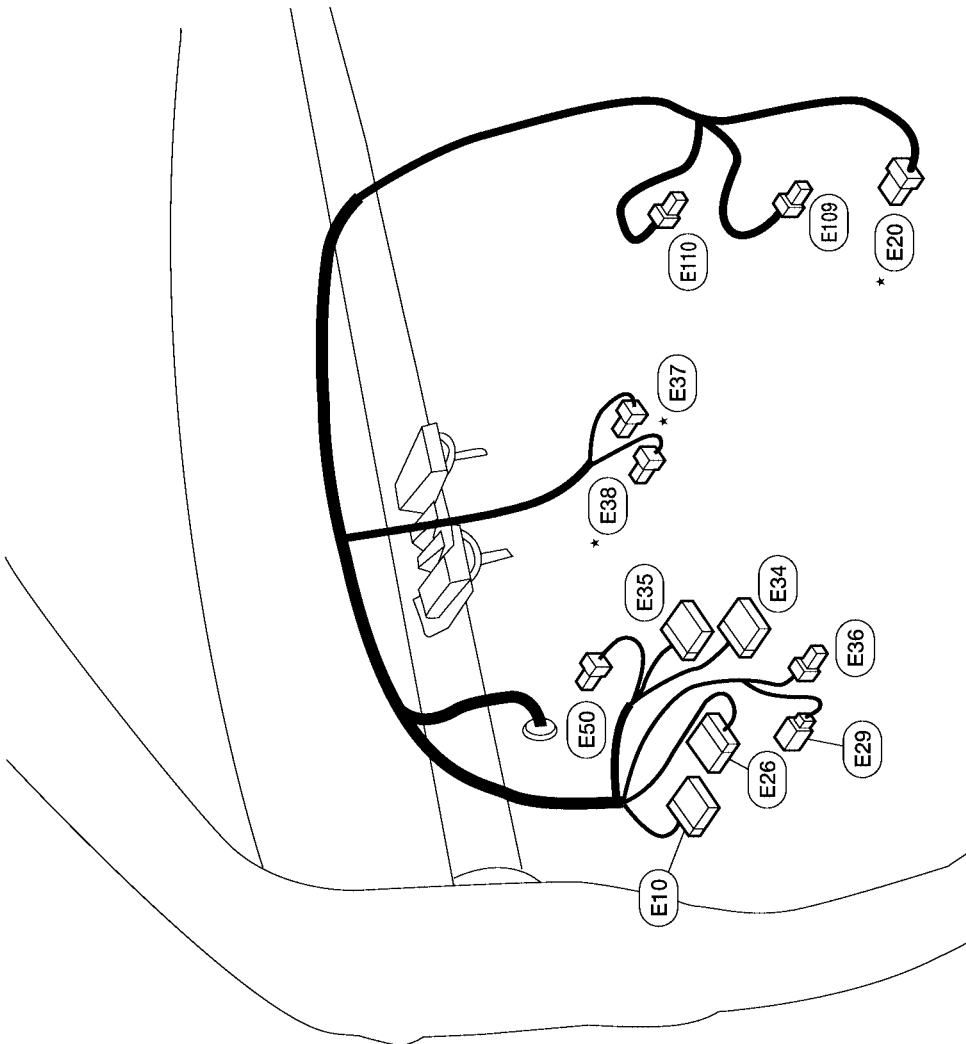

* : Be sure to connect and lock the connectors securely after repair work. Failure to do so may cause the ECM to have diagnostic trouble codes.
 Do not disconnect these connectors except in the case of working according to WORK FLOW of TROUBLE DIAGNOSES in EC and AT sections.

A
B
C
D
E
F
G
H
I
J
PG
L
M

HARNESS

ENGINE ROOM HARNESS (RH VIEW) Engine Compartment

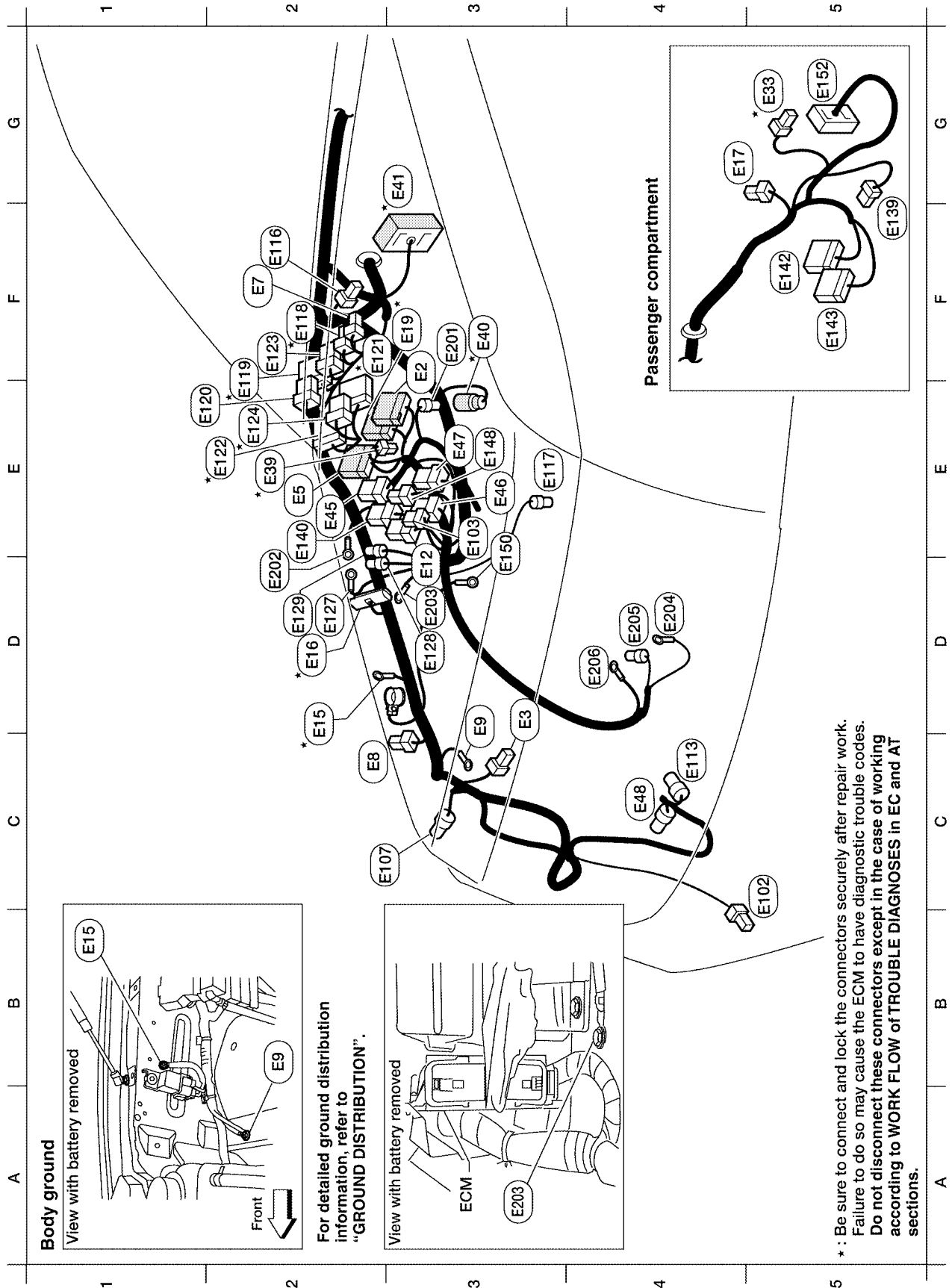

Refer to [PG-43, "ENGINE ROOM HARNESS \(LH VIEW\)"](#) for continuation of engine room harness.

WKIA3701E

E3	E2	W/16	: To	F32
C3	E3	B/2	: Horn	
E2	E5	W/24	: To	F14
F2	E7	GR/2	: Fuse and fusible link box	
F2	E8	GR/2	: Dropping resistor	
C3	E9	-	: Body ground	
D3	E12	B/5	: Stop lamp relay	
C2	E15	-	: Body ground	
D2	E16	B/32	: ECM	
F3	E19	W/16	: To	F33
G5	E33	B/1	: To	M66
E2	E39	W/2	: To	F34
F3	E40	GR/2	: To	E201
F3	E41	SMJ	: To	C1
E2	E45	BR/6	: Back-up lamp relay	
E3	E46	L/5	: Transfer relay 1	
E3	E47	L/5	: Transfer relay 2	
C4	E48	B/3	: Refrigerant pressure sensor	
C5	E102	B/2	: Front fog lamp RH	
E3	E103	B/5	: Daytime light relay	
C2	E107	B/6	: Front combination lamp RH	
C4	E113	GR/2	: Cooling fan motor	
F2	E116	W/2	: Condenser-2	
E3	E117	GR/2	: Front wheel sensor RH	
F2	E118	B/2	: IPDM E/R (intelligent power distribution module engine room)	
E2	E119	W/16	: IPDM E/R (intelligent power distribution module engine room)	
E2	E120	W/6	: IPDM E/R (intelligent power distribution module engine room)	
F3	E121	BR/12	: IPDM E/R (intelligent power distribution module engine room)	
E2	E122	W/12	: IPDM E/R (intelligent power distribution module engine room)	
F2	E123	BR/8	: IPDM E/R (intelligent power distribution module engine room)	
E2	E124	B/6	: IPDM E/R (intelligent power distribution module engine room)	
D2	E127	-	: Fuse link box (battery)	
D3	E128	GR/2	: Fuse link box (battery)	
D2	E129	BR/2	: Fuse link box (battery)	
F5	E139	W/8	: To	E107
E2	E140	BR/6	: Trailer tow relay 2	
F5	E142	W/26	: Transfer control unit	
F5	E143	W/24	: Transfer control unit	
E3	E148	L/4	: Trailer tow relay 1	
E3	E150	-	: Battery ground	
D3	E161	-	: Negative battery cable	
G5	E152	SMJ	: To	N31

Generator sub-harness

F3	E201	GR/2	: To	E40
D2	E202	B/1	: To fuse and fusible link box	
D3	E203	-	: Body ground	
D4	E204	-	: Generator	
D4	E205	GR/2	: Generator	
D4	E206	-	: Generator	

* : Be sure to connect and lock the connectors securely after repair work.
Failure to do so may cause the ECM to have diagnostic trouble codes.
Do not disconnect these connectors except in the case of working according to WORK FLOW of TROUBLE DIAGNOSES in EC and AT sections.

HARNESS

ENGINE CONTROL HARNESS

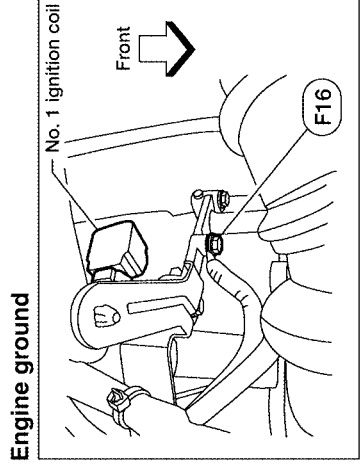
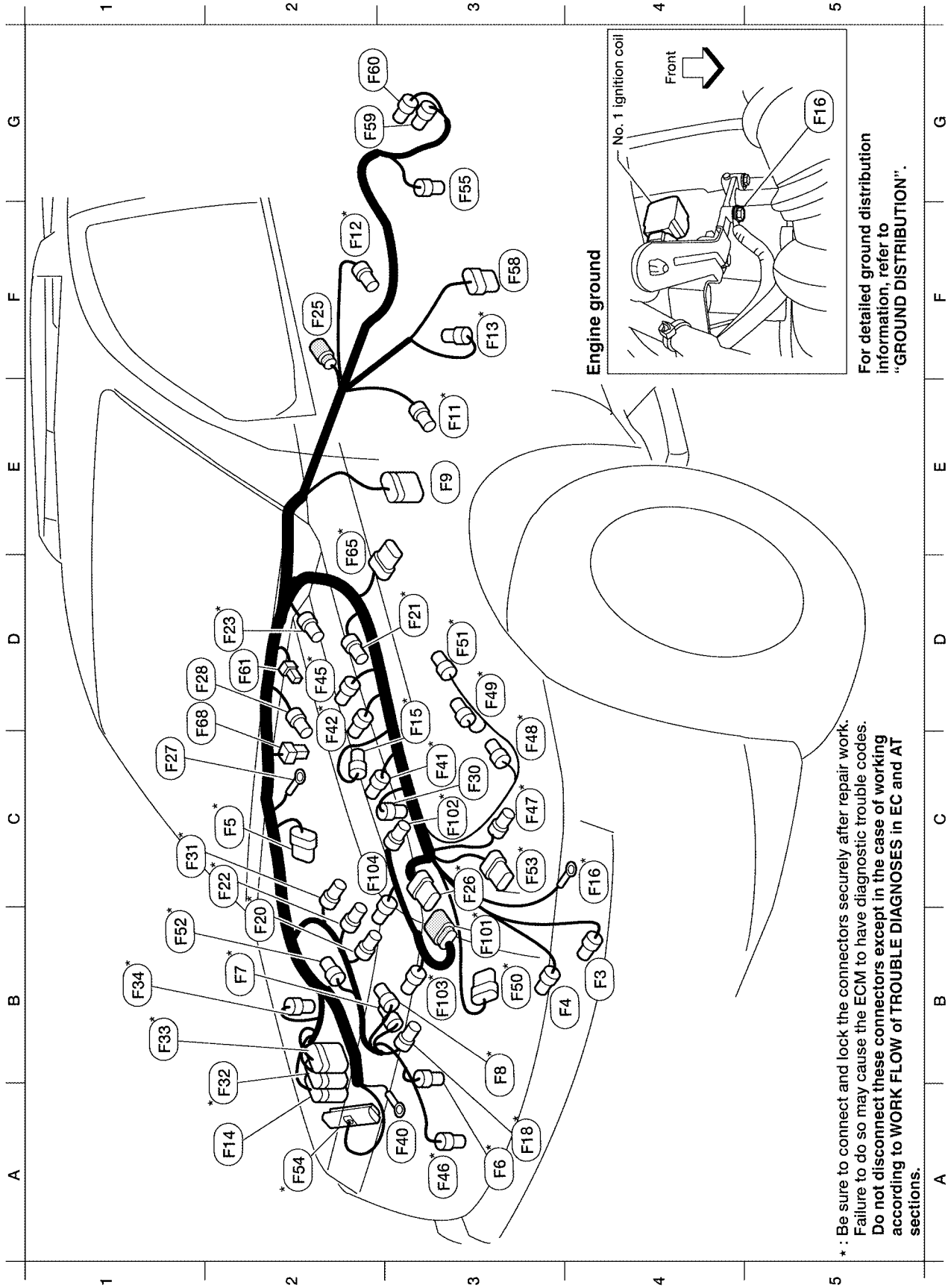

For detailed ground distribution information, refer to "GROUND DISTRIBUTION".

* : Be sure to connect and lock the connectors securely after repair work. Failure to do so may cause the ECM to have diagnostic trouble codes. Do not disconnect these connectors except in the case of working according to WORK FLOW of TROUBLE DIAGNOSES in EC and AT sections.

WKIA3702E

B4	F3	B/1	: A/C Compressor			
B4	F4	B/3	: Oil pressure sensor			
C2	F5	B/6	: Air/fuel ratio (A/F) sensor 1 (bank 2)			
A3	F6	GR/3	: Ignition coil No. 2 (with power transistor)			
B2	F7	GR/3	: Ignition coil No. 4 (with power transistor)			
B3	F8	GR/3	: Ignition coil No. 6 (with power transistor)			
E3	F9	G/10	: A/T assembly			
E3	F10	-	: Ground			
E3	F11	B/3	: Crankshaft position sensor (POS)			
F2	F12	G/4	: Heated oxygen sensor 2 (bank 2)			
F3	F13	G/4	: Heated oxygen sensor 2 (bank 1)			
A2	F14	W/24	: To (E5)			
C3	F15	L/2	: EVAP canister purge volume control solenoid valve			
C4	F16	-	: Engine ground			
A3	F18	GR/2	: Injector No. 2			
B2	F20	GR/2	: Injector No. 4			
D3	F21	GR/2	: Condenser-1			
C2	F22	GR/2	: Injector No. 6			
D2	F23	B/3	: Camshaft position sensor (PHASE)			
F2	F25	W/2	: Diode No. 2			
C3	F26	B/6	: To (F10)			
C1	F27	B/1	: Starter motor			
D2	F28	GR/1	: Starter motor			
C3	F30	GR/2	: Injector No. 1			
C1	F31	GR/2	: Injector No. 8			
A2	F32	W/16	: To (E2)			
B1	F33	W/16	: To (E19)			
B1	F34	W/2	: To (E39)			
A3	F39	-	: Fusible link box (battery)			
A3	F40	-	: Fusible link box (battery)			
C3	F41	GR/2	: Injector No. 3			
C2	F42	GR/2	: Injector No. 5			
D2	F45	GR/2	: Injector No. 7			
A3	F46	B/3	: Power steering pressure sensor			
C3	* F47	GR/3	: Ignition coil No. 1 (with power transistor)			
C3	* F48	GR/3	: Ignition coil No. 3 (with power transistor)			
D3	* F49	GR/3	: Ignition coil No. 5 (with power transistor)			
B3	* F50	B/6	: Electric throttle control actuator			
D3	* F51	GR/3	: Ignition coil No. 7 (with power transistor)			
B1	* F52	GR/3	: Ignition coil No. 8 (with power transistor)			
C3	* F53	B/6	: Mass air flow sensor			
A2	* F54	B/81	: ECM			
G3	* F55	B/2	: ATP switch (4WD only)			
F3	F56	B/8	: Transfer control device (4WD only)			
G2	F59	GR/2	: Wait detection switch (4WD only)			
G2	F60	GR/2	: 4LO switch (4WD only)			
D2	F61	W/2	: Condenser-2			
D2	* F65	B/6	: Air/fuel ratio (A/F) sensor 1 (bank 1)			
D1	* F68	B/2	: Water valve			
Engine control sub-harness						
B3	* F101	B/6	: To (F26)			
C3	* F102	GR/2	: Knock sensor (bank 1)			
B3	* F103	GR/2	: Engine coolant temperature sensor			
C2	* F104	GR/2	: Knock sensor (bank 2)			

* : Be sure to connect and lock the connectors securely after repair work.
 Failure to do so may cause the ECM to have diagnostic trouble codes.
 Do not disconnect these connectors except in the case of working according to WORK FLOW of TROUBLE DIAGNOSES in EC and AT sections.

HARNESS

CHASSIS HARNESS

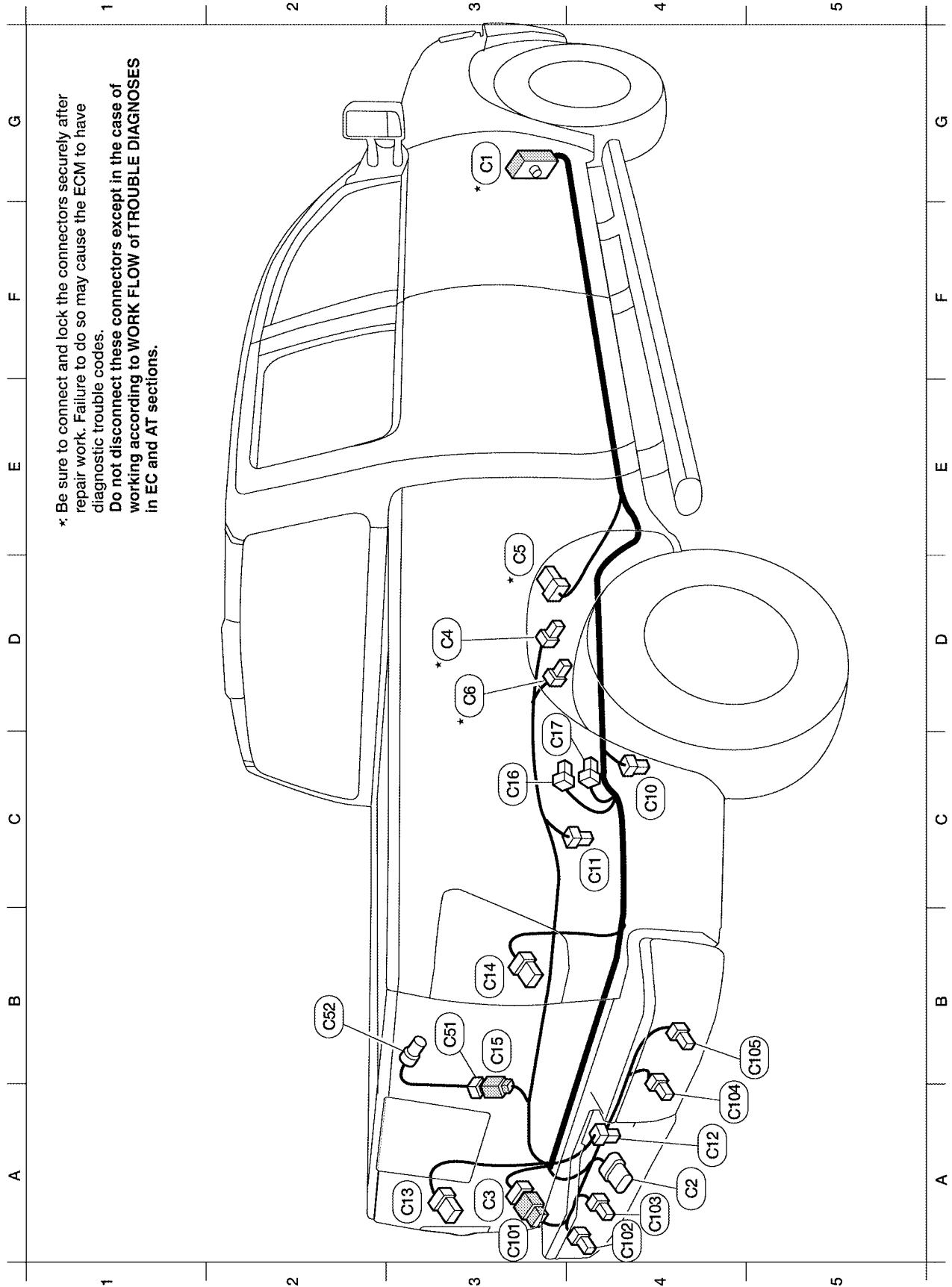

WKIA3703E

G3	*	C1	SMJ	:	To	(E41)
A4		C2	B/7	:	Trailer	
A3		C3	GR/6	:	To	(C10)
D3	*	C4	GR/3	:	EVAP control system pressure sensor	
D3	*	C5	GR/5	:	Fuel level sensor unit and fuel pump	
D3	*	C6	B/2	:	EVAP canister vent control valve	
C4		C10	GR/2	:	Rear wheel sensor RH	
C4		C11	BR/2	:	Rear wheel sensor LH	
A4		C12	W/2	:	License plate lamps	
A3		C13	GR/8	:	Rear combination lamp LH	
B3		C14	GR/8	:	Rear combination lamp RH	
B3		C15	W/2	:	To	(C61)
C3		C16	GR/2	:	Differential lock position switch	
C3		C17	B/2	:	Differential lock solenoid	
Rear power socket sub-harness						
B3		C51	W/2	:	To	(C15)
B2		C52	BR/2	:	Rear cargo bed power socket	
Rear sonar system sensor sub-harness						
A3		C101	GR/6	:	To	(C3)
A4		C102	B/3	:	Rear sonar system sensor (LH outer)	
A4		C103	B/3	:	Rear sonar system sensor (LH inner)	
A4		C104	B/3	:	Rear sonar system sensor (RH inner)	
B5		C105	B/3	:	Rear sonar system sensor (RH outer)	

* : Be sure to connect and lock the connectors securely after repair work.
 Failure to do so may cause the ECM to have diagnostic trouble codes.
 Do not disconnect these connectors except in the case of working
 according to WORK FLOW of TROUBLE DIAGNOSES in EC and AT
 sections.

HARNESS

BODY HARNESS (KING CAB MODELS)

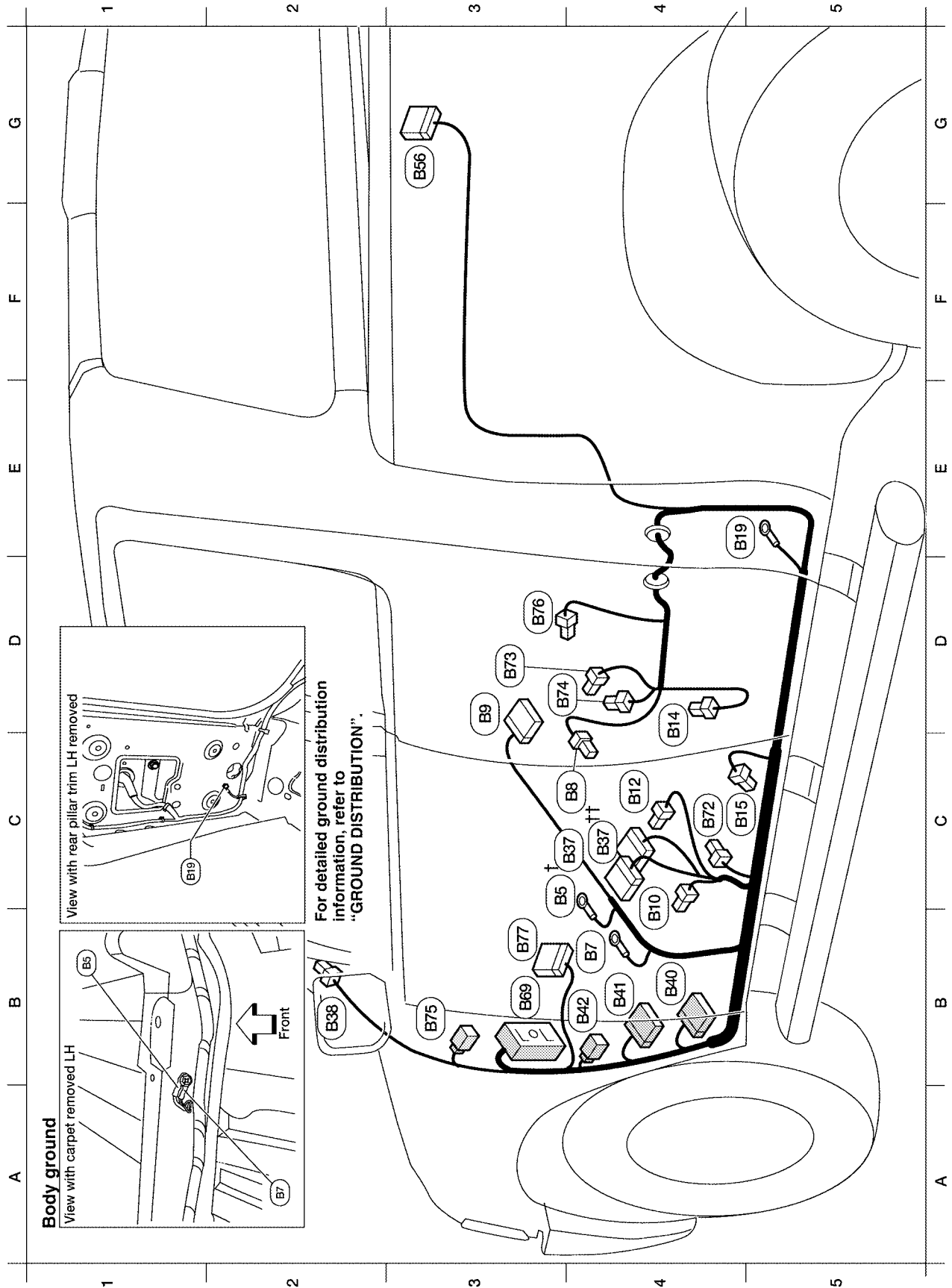

WKIA3704E

HARNESS

C3	(B5)	-	: Body ground (LH satellite sensor)
B4	(B7)	-	: Body ground
C4	(B8)	W/3	: Front door switch LH
D3	(B9)	Y/12	: Air bag diagnosis sensor unit
B4	(B10)	Y/2	: Front LH side air bag module
C4	(B12)	W/3	: Seat belt buckle switch LH
D4	(B14)	Y/2	: Front LH seat belt pre-tensioner
C4	(B15)	Y/2	: LH side air bag (satellite) sensor
E5	(B19)	-	: Body ground
C4	(B37)	W/2	: To (P1) (without memory)
C4	† (B37)	W/16	: To (P1) (with memory)
B2	(B38)	Y/2	: LH side curtain air bag module
B4	(B40)	W/24	: To (E34)
B4	(B41)	W/12	: To (E35)
B4	(B42)	W/2	: To (E36)
G3	(B56)	W/16	: Sonar control unit
B3	(B69)	SMJ	: To (M40)
C4	(B72)	W/4	: Subwoofer (with premium audio system)
D3	(B73)	B/2	: Rear door switch upper LH
D3	(B74)	B/2	: Rear door switch lower LH
B3	(B75)	BR/2	: To (E50)
D3	(B76)	W/2	: Rear door speaker LH
B3	(B77)	B/26	: Differential lock control unit

A
B
C
D
E
F
G
H
I
J

PG

L
M

WKIA3641E

HARNESS

BODY HARNESS (CREW CAB MODELS)

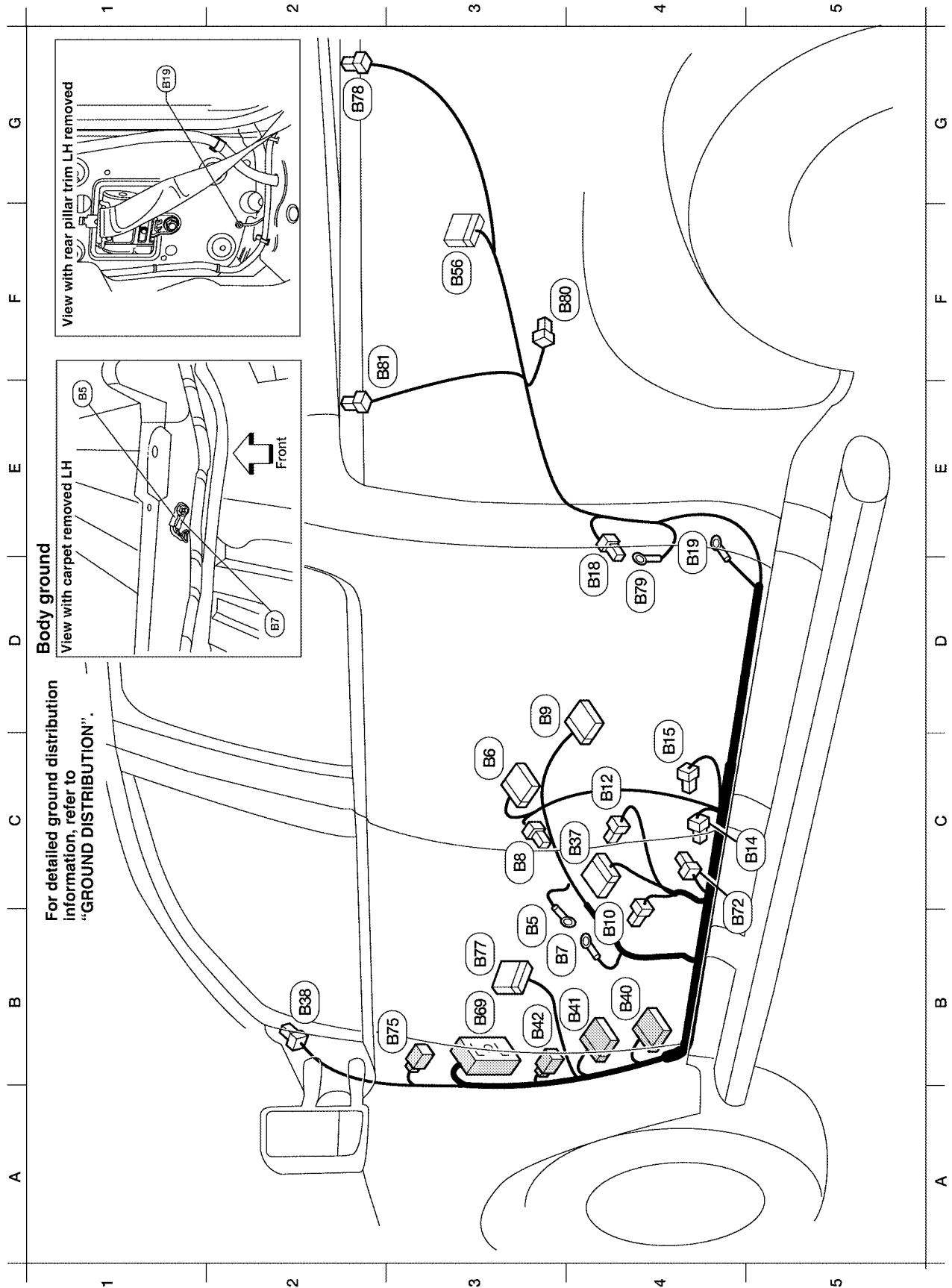

WKIA3705E

HARNESS

B3	(B5)	-	: Body ground (LH satellite sensor)
C3	(B6)	W/18	: To (C201)
B3	(B7)	-	: Body ground
C3	(B8)	W/3	: Front door switch LH
C3	(B9)	Y/12	: Air bag diagnosis sensor unit
B4	(B10)	Y/2	: Front LH side air bag module
C3	(B12)	W/3	: Seat belt buckle switch LH
C4	(B14)	Y/2	: Front LH seat belt pre-tensioner
C4	(B15)	Y/2	: LH side air bag (satellite) sensor
D4	(B18)	W/3	: Rear door switch LH
E4	(B19)	-	: Body ground
C3	(B37)	W/16	: To (P1)
B2	(B38)	Y/2	: LH side curtain air bag module
B4	(B40)	W/24	: To (E34)
B4	(B41)	W/12	: To (E35)
B3	(B42)	W/2	: To (E36)
F3	(B56)	W/16	: Sonar control unit
B3	(B69)	SMJ	: To (M40)
B4	(B72)	W/4	: Subwoofer (with premium audio system)
B3	(B75)	BR/2	: To (E50)
F2	(B76)	B/1	: Rear window defogger
G2	(B81)	B/1	: Rear window defogger
D4	(B79)	-	: Body ground
F3	(B80)	GR/4	: Power window motor drop glass

A
B
C
D
E
F
G
H
I
J
PG
L
M

HARNESS

BODY NO. 2 HARNESS (KING CAB MODELS)

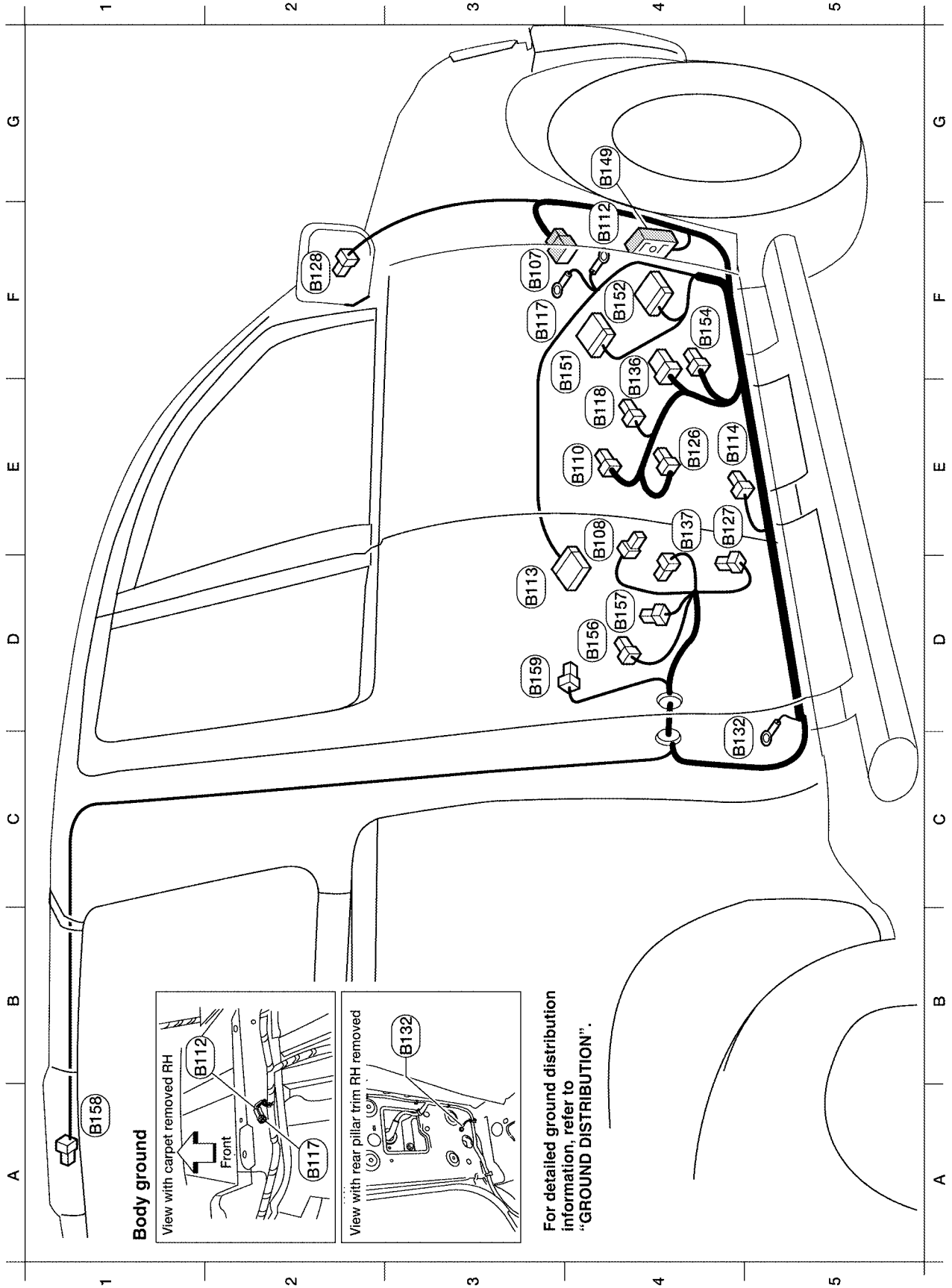

LKIA0462E

HARNESS

F3	(E107)	W/8	:	To	(E139)						
D4	(E108)	W/3	:	Front door switch RH							
E4	(E110)	W/3	:	Seat belt buckle switch RH							
F4	(E112)	-	:	Body ground (RH satellite sensor)							
D3	(E113)	Y/12	:	Air bag diagnosis sensor unit							
E5	(E114)	Y/2	:	RH side air bag (satellite) sensor							
F3	(E117)	-	:	Body ground							
E4	(E118)	W/3	:	Front seat heater RH							
E4	(E126)	Y/2	:	Front RH side air bag module							
D5	(E127)	Y/2	:	Front RH seat belt pre-tensioner							
F2	(E128)	Y/2	:	RH side curtain air bag module							
C4	(E132)	-	:	Body ground							
E4	(E136)	W/8	:	To	(P151)						
D4	(E137)	B/3	:	Belt tension sensor							
G4	(E149)	SMJ	:	To	(M36)						
F4	(E151)	W/24	:	NAVI control unit (with NAVI)							
F4	(E152)	GR/24	:	NAVI control unit (with NAVI)							
F4	(E154)	W/2	:	To	(P103)						
D4	(E156)	B/2	:	Rear door switch upper RH							
D4	(E157)	B/2	:	Rear door switch lower RH							
A1	(E158)	W/3	:	High mounted stop lamp							
D3	(E159)	W/2	:	Rear door speaker RH							

A
B
C
D
E
F
G
H
I
J

PG

L

M

WKIA2867E

HARNESS

BODY NO. 2 HARNESS (CREW CAB MODELS)

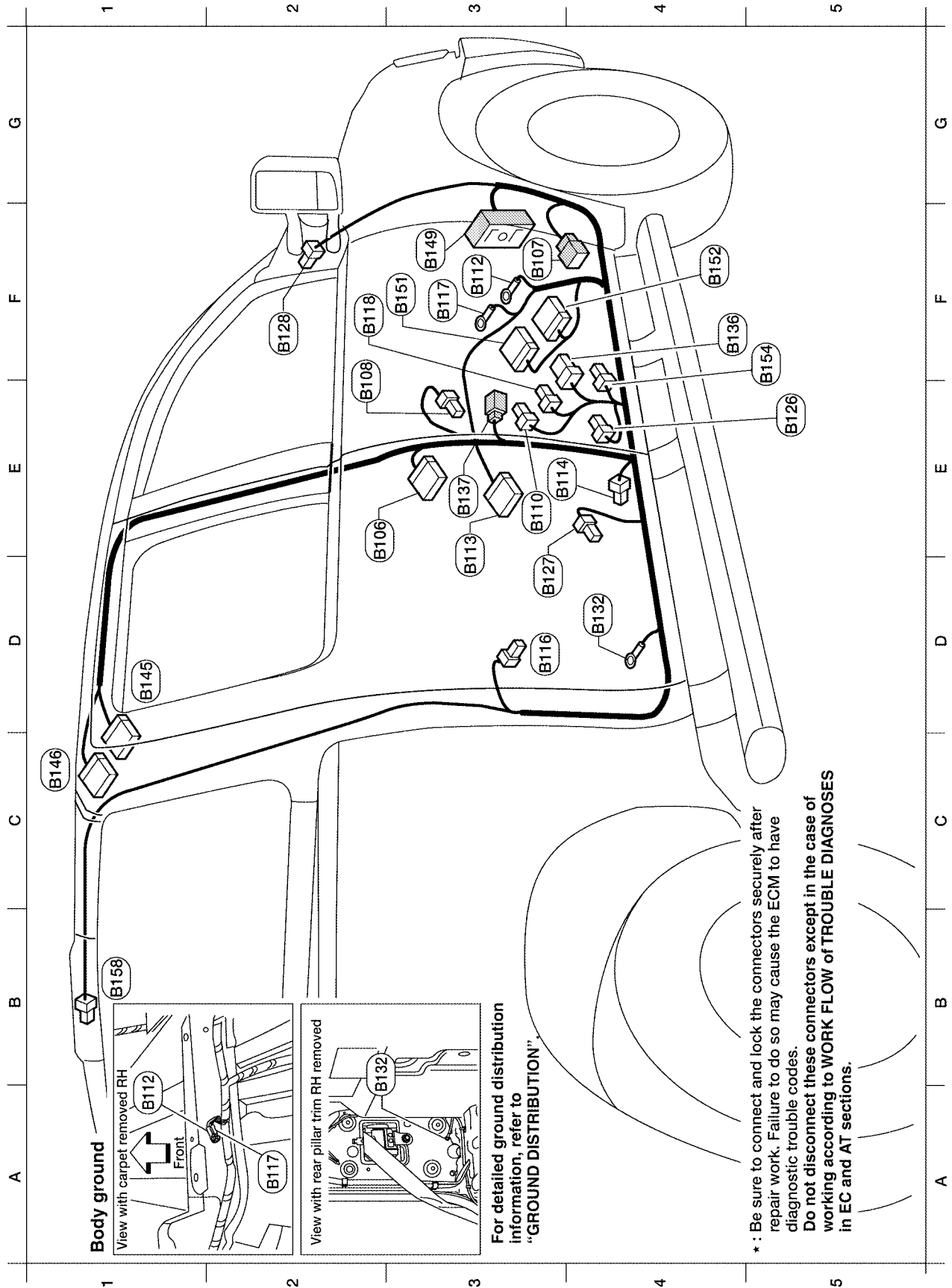

HARNESS

F3 (6149) SMJ : To (M36)
 F3 (6151) W/24 : NAVI control unit (with NAVI)
 F4 (6152) GR/24 : NAVI control unit (with NAVI)
 F5 (6154) W/2 : To (F103)

D3 (6106) W/18 : To (G301)
 F3 (6107) W/8 : To (E139)
 E2 (6108) W/3 : Front door switch RH
 E4 (6110) W/3 : Seat belt buckle switch RH
 F3 (6112) - : Body ground (RH satellite sensor)
 E3 (6113) Y/12 : Air bag diagnosis sensor unit
 E3 (6114) Y/2 : RH side air bag (satellite) sensor
 D3 (6116) W/3 : Rear door switch RH
 F3 (6117) - : Body ground
 F2 (6118) W/3 : Front seat heater RH
 E5 (6126) Y/2 : Front RH side air bag module
 D4 (6127) Y/2 : Front RH seat belt pre-tensioner
 F2 (6128) Y/2 : RH side curtain air bag module
 D4 (6132) - : Body ground
 F4 (6136) W/8 : To (F151)
 E3 (6137) B/3 : Belt tension sensor
 D1 (6145) W/16 : To (F200)
 C1 (6146) BR/24 : To (F201)

A
 B
 C
 D
 E
 F
 G
 H
 I
 J
 PG
 L
 M

HARNESS

ROOM LAMP HARNESS

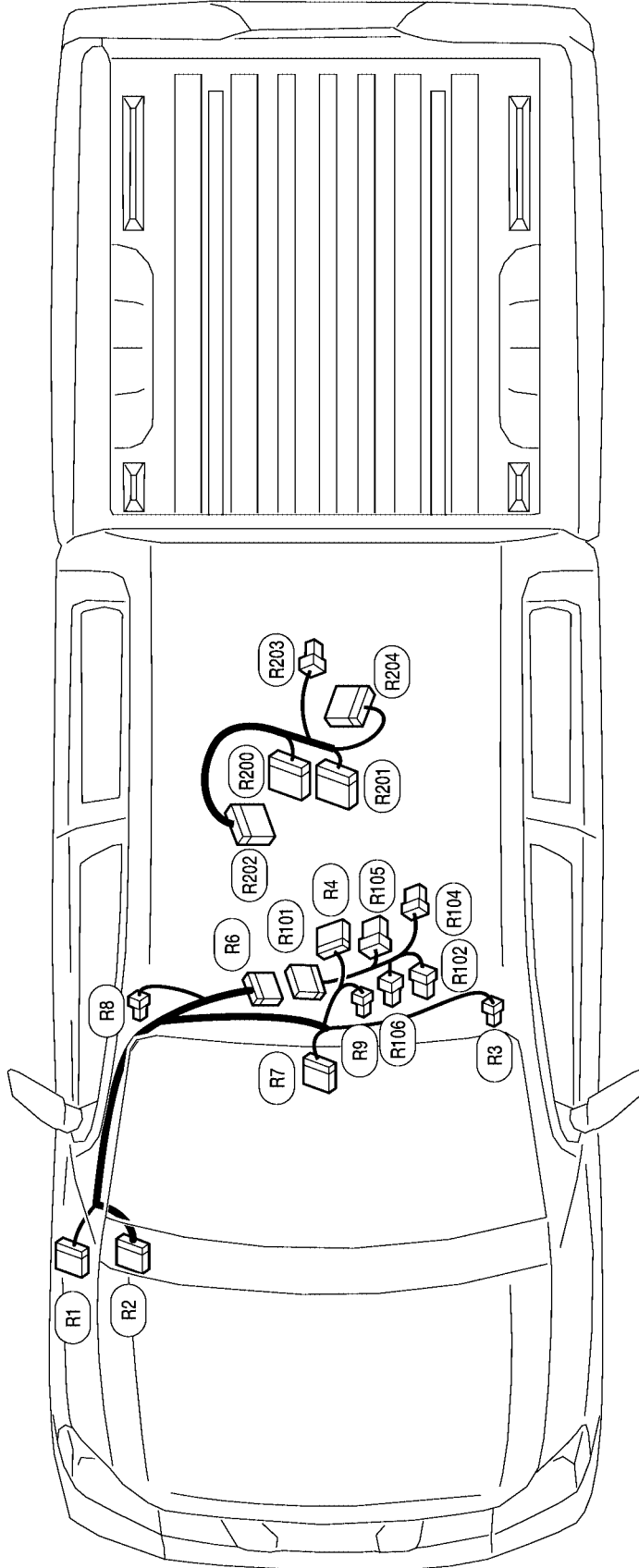

Room lamp sub-harness B (Crew Cab)

- (R200) W/16 : To (B145)
- (R201) BR/24 : To (B146)
- (R202) W/12 : Video monitor
- (R203) W/3 : Personal lamp 2nd row
- (R204) W/16 : Rear audio remote control unit

- (R1) W/16 : To (M1)
- (R2) W/12 : To (M2)
- (R3) W/2 : Vanity lamp LH
- (R4) W/10 : Sunroof motor assembly
- (R6) W/24 : To (R101)
- (R7) B/7 : Auto anti-dazzling inside mirror
- (R8) W/2 : Vanity lamp RH
- (R9) W/2 : Room lamp

Room lamp sub-harness A (Crew Cab)

- (R101) W/24 : To (R6)
- (R102) GR/8 : Front room/map lamp assembly
- (R104) GR/6 : Sunroof switch
- (R105) W/8 : Compass/thermometer
- (R106) W/2 : Hemlink universal transceiver

WKIA3645E

HARNESS

FRONT DOOR HARNESS LH

- | | |
|---|--|
| (D1) BR/24 : To (M9) | (D6) W/3 : Main power window and door lock/unlock switch |
| (D2) W/16 : To (M8) | (D9) GR/6 : Front power window motor LH |
| † (D4) W/16 : Door mirror LH (with automatic drive positioner) | (D10) W/16 : Door mirror remote control switch |
| †† (D4) W/6 : Door mirror LH (without automatic drive positioner) | (D11) W/2 : Front step lamp LH |
| (D5) W/8 : Seat memory switch | (D12) W/2 : Front door speaker LH |
| (D7) W/16 : Main power window and door lock/unlock switch | (D14) B/6 : Front door lock assembly LH |

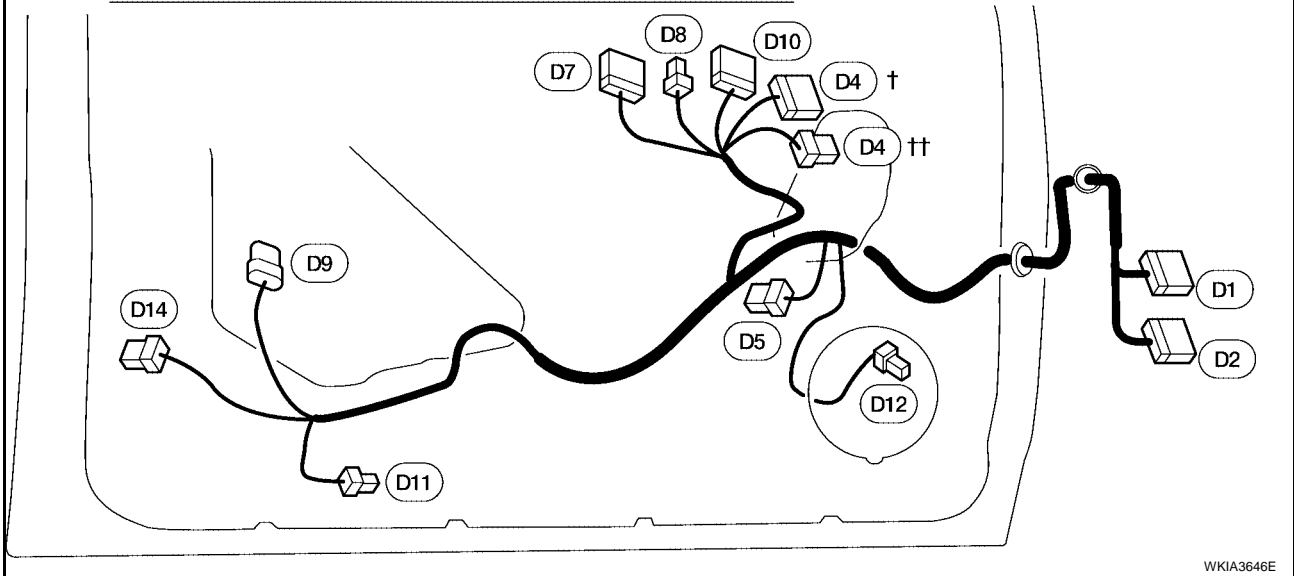

WKIA3646E

FRONT DOOR HARNESS RH

- | | |
|---|---|
| (D101) W/8 : To (M75) | † (D107) W/16 : Door mirror RH (with automatic drive positioner) |
| (D102) W/20 : To (M74) | †† (D107) W/6 : Door mirror RH (without automatic drive positioner) |
| (D104) GR/6 : Front power window motor RH | (D109) W/2 : Front step lamp RH |
| (D105) W/16 : Power window and door lock/unlock switch RH | (D112) W/2 : Front door speaker RH |
| | (D114) B/6 : Front door lock actuator RH |

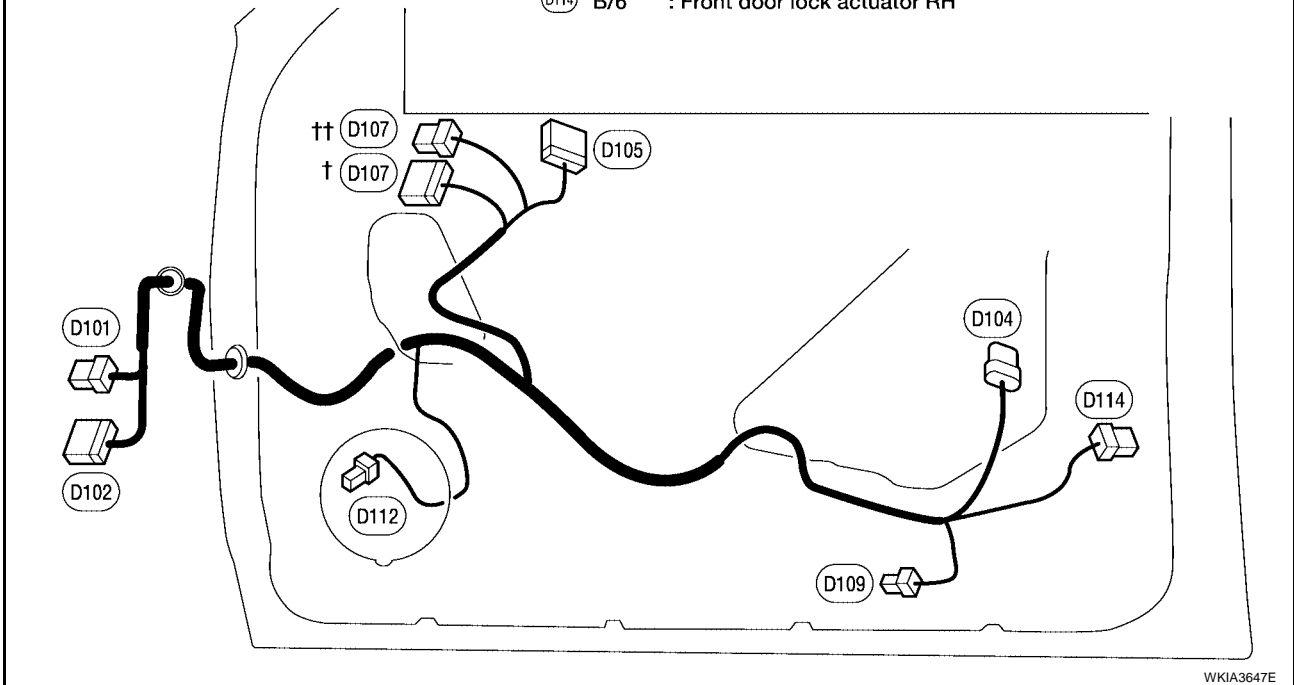

WKIA3647E

A
B
C
D
E
F
G
H
I
J
PG
L
M

HARNESS

REAR DOOR HARNESS LH (CREW CAB MODELS)

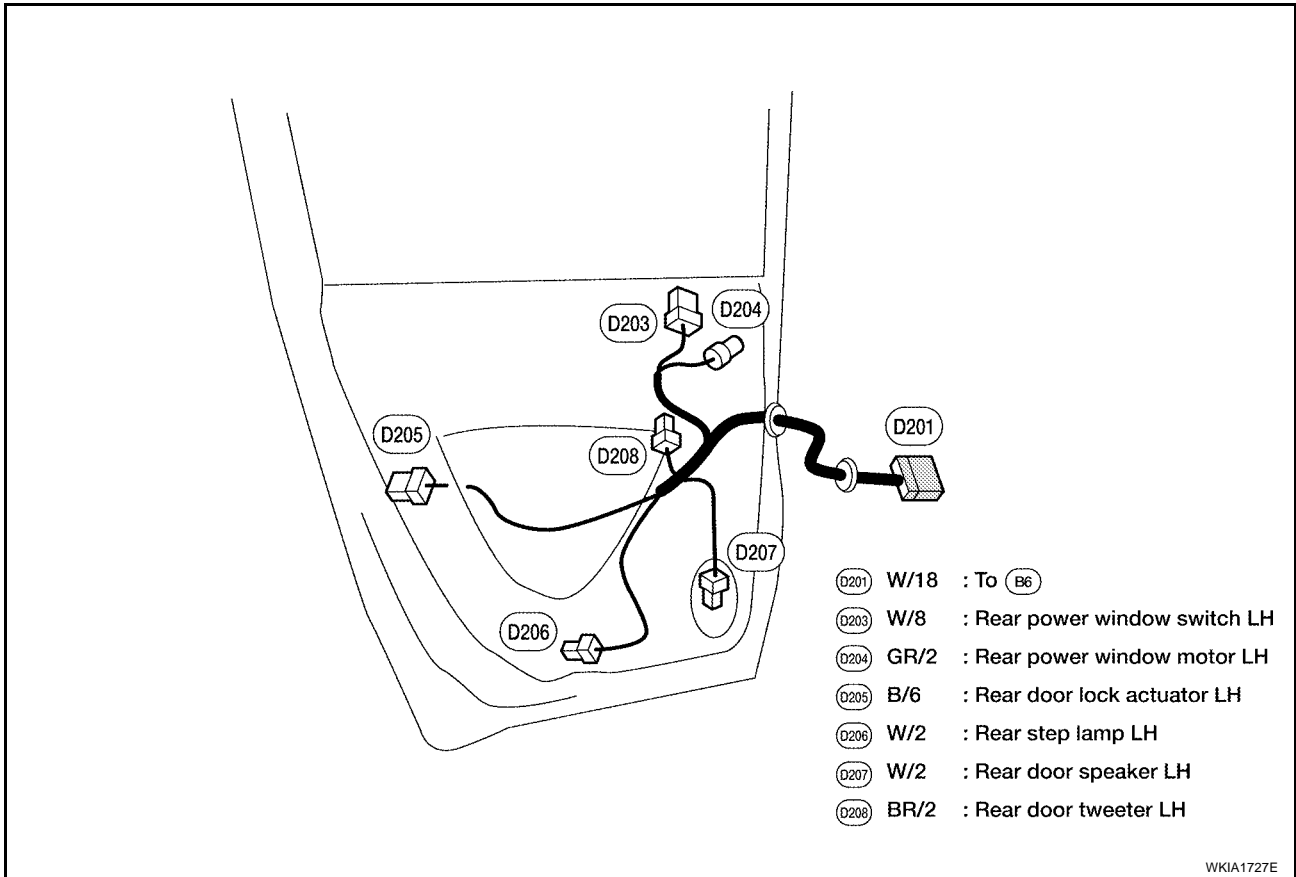

WKIA1727E

REAR DOOR HARNESS RH (CREW CAB MODELS)

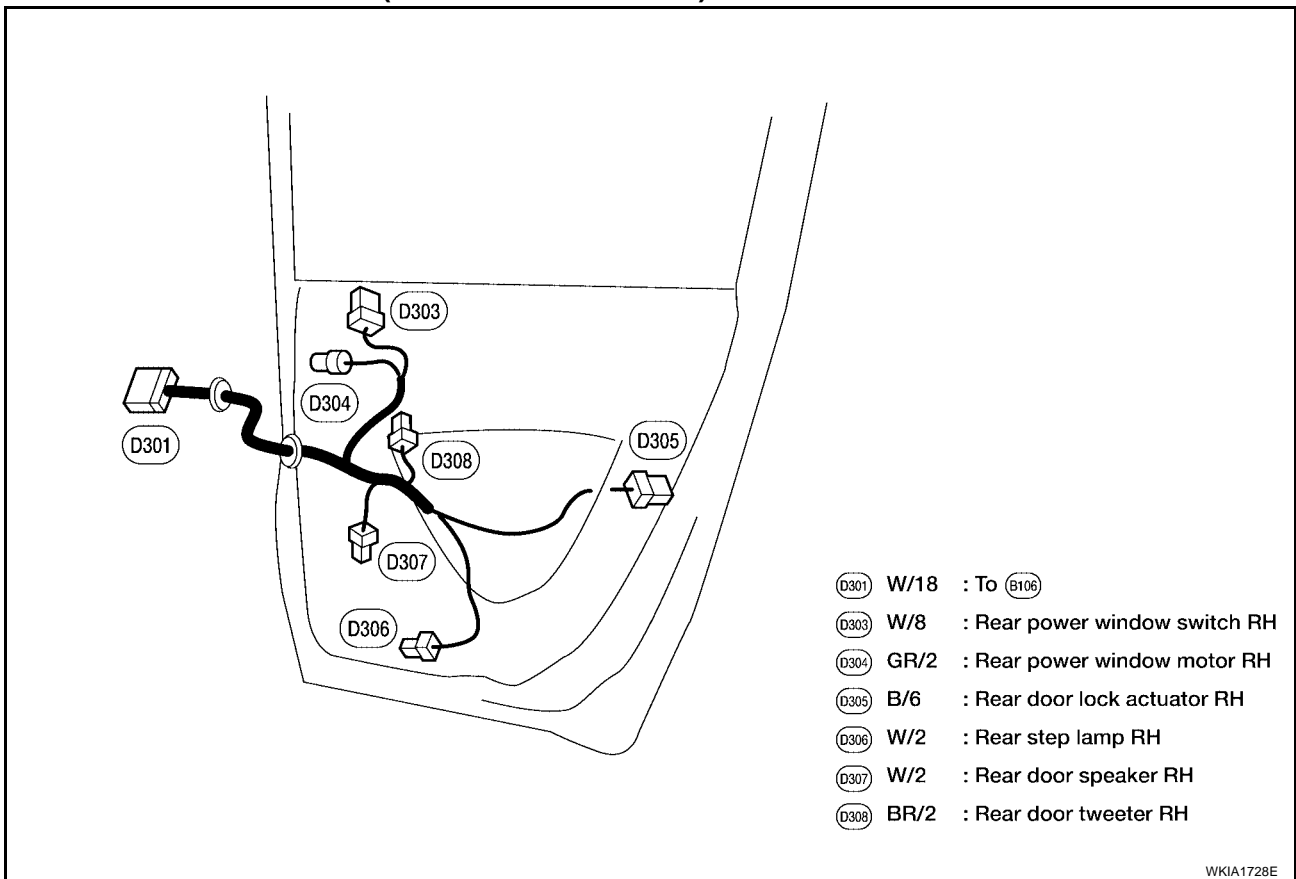

WKIA1728E

HARNESS

Wiring Diagram Codes (Cell Codes)

EKS00ARK

Use the chart below to find out what each wiring diagram code stands for. Refer to the wiring diagram code in the alphabetical index to find the location (page number) of each wiring diagram.

Code	Section	Wiring Diagram Name
A/C,M	MTC	Manual Air Conditioner
AF1B1	EC	Air Fuel Ratio Sensor 1 Bank 1
AF1B2	EC	Air Fuel Ratio Sensor 1 Bank 2
APPS1	EC	Accelerator Pedal Position Sensor
APPS2	EC	Accelerator Pedal Position Sensor
APPS3	EC	Accelerator Pedal Position Sensor
ABLS	BRC	Anti-Lock Brake System Limited Slip
ABS	BRC	Anti-Lock Brake System
ASC/BS	EC	ASCD Brake Switch
ASC/SW	EC	ASCD Steering Switch
ASCBOF	EC	ASCD Brake Switch
ASCIND	EC	ASCD Indicator
A/T	AT	A/T Assembly
AT/IND	DI	A/T Indicator Lamp
AUDIO	AV	Audio
AUTO/DP	SE	Automatic Drive Positioner
AUTO/L	LT	Auto Light Control
BACK/L	LT	Back-up Lamp
BRK/SW	EC	Brake Switch
CAN	EC	CAN Communication Line
CAN	LAN	CAN System
CHARGE	SC	Charging System
COOL/F	EC	Cooling Fan Control
COMBSW	LT	Combination Switch
COMM	AV	Audio Visual Communication System
COMPAS	DI	Compass and Thermometer
D/LOCK	BL	Power Door Lock
DIFLOC	DI	Rear Final Drive
DEF	GW	Rear Window Defogger
DTRL	LT	Headlamp - With Daytime Light System
DVD	AV	DVD Entertainment System
ECM/PW	EC	ECM Power Supply for Back-Up
ECTS	EC	Engine Coolant Temperature Sensor
ETC1	EC	Electric Throttle Control Function
ETC2	EC	Throttle Control Motor Relay
ETC3	EC	Throttle Control Motor
F/FOG	LT	Front Fog Lamp
F/PUMP	EC	Fuel Pump
FTTS	EC	Fuel Tank Temperature Sensor
FUELB1	EC	Fuel Injection System Bank 1
FUELB2	EC	Fuel Injection System Bank 2
H/LAMP	LT	Headlamp
HORN	WW	Horn
HSEAT	SE	Heated Seat
I/MIRR	GW	Inside Mirror (Auto Anti-Dazzling Mirror)
IATS	EC	Intake Air Temperature Sensor
IGNSYS	EC	Ignition System

HARNESS

ILL	LT	Illumination
INJECT	EC	Injectors
INT/L	LT	Room/Map, Vanity, Cargo, Personal, Foot, Step, and Puddle Lamps
KEYLES	BL	Remote Keyless Entry System
KS	EC	Knock Sensor
MAFS	EC	Mass Air Flow Sensor
MAIN	EC	Main Power Supply and Ground Circuit
METER	DI	Speedometer, Tachometer, Temp. and Fuel Gauges
MIL/DL	EC	Malfunction Indicator Lamp
MIRROR	GW	Door Mirror
MMSW	AT	Manual Mode Switch
NATS	BL	Nissan Anti-Theft System
NAVI	AV	Navigation System
O2H2B1	EC	Rear Heated Oxygen Sensor 2 Heater Bank 1
O2H2B2	EC	Rear Heated Oxygen Sensor 2 Heater Bank 2
O2S2B1	EC	Heated Oxygen Sensor 2 Bank 1
O2S2B2	EC	Heated Oxygen Sensor 2 Bank 2
P/SCKT	WW	Power Socket
PEDAL	AP	Adjustable Pedal System
PGC/V	EC	EVAP Canister Purge Volume Control Solenoid Valve
PHASE	EC	Camshaft Position Sensor (PHASE) (Bank 1)
PNP/SW	EC	Park/Neutral Position Switch
POS	EC	Crankshaft Position Sensor (POS)
POWER	PG	Power Supply Routing
PRE/SE	EC	EVAP Control System Pressure Sensor
PS/SEN	EC	Power Steering Pressure Sensor
RP/SEN	EC	Refrigerant Pressure Sensor
SEAT	SE	Power Seat
SEN/PW	EC	Sensor Power Supply
SHIFT	AT	A/T Shift Lock System
SONAR	DI	Rear Sonar System
SROOF	RF	Sunroof
SRS	SRS	Supplemental Restraint System
START	SC	Starting System
STOP/L	LT	Stop Lamp
T/TOW	LT	Trailer Tow
T/WARN	WT	Low Tire Pressure Warning System
TAIL/L	LT	Parking, License and Tail Lamps
T/F	TF	Transfer Case
TPS1	EC	Throttle Position Sensor
TPS2	EC	Throttle Position Sensor
TPS3	EC	Throttle Position Sensor
TRNSCV	BL	HOMELINK® Universal Transceiver
TURN	LT	Turn Signal and Hazard Warning Lamps
VDC	BRC	Vehicle Dynamic Control System
VEHSEC	BL	Vehicle security (theft warning) system
VENT/V	EC	EVAP Canister Vent Control Valve
WARN	DI	Warning Lamps
WINDOW	GW	Power Window
WIPER	WW	Front Wiper and Washer

ELECTRICAL UNITS LOCATION

PF2:25230

ELECTRICAL UNITS LOCATION

Electrical Units Location ENGINE COMPARTMENT

EKS00ARL

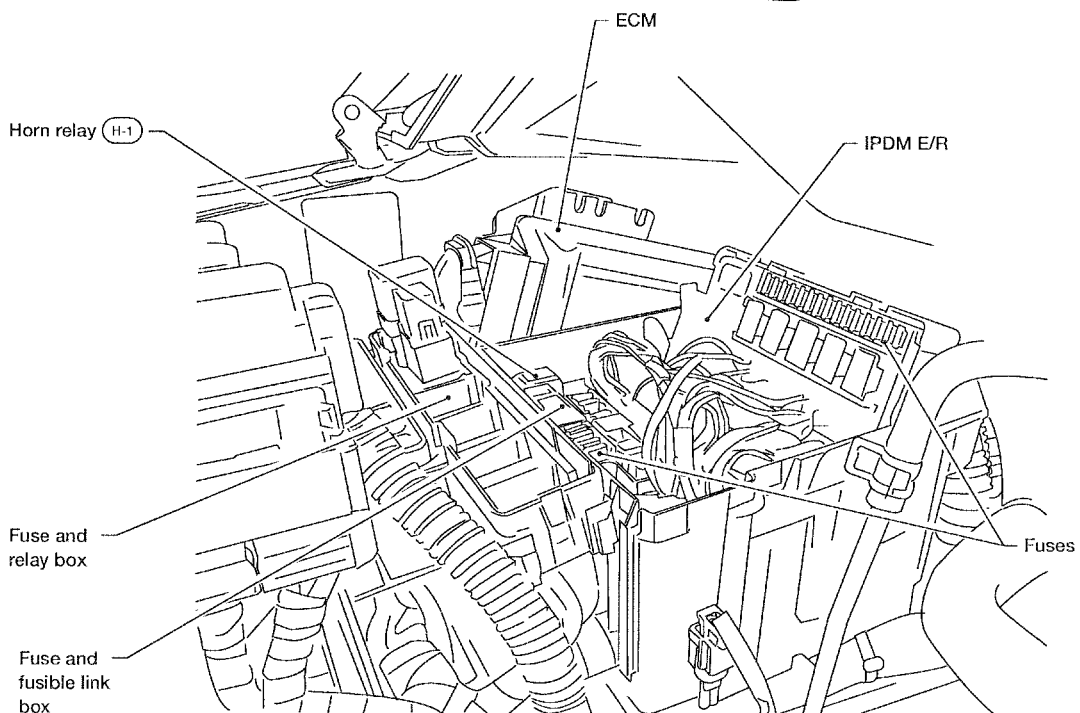
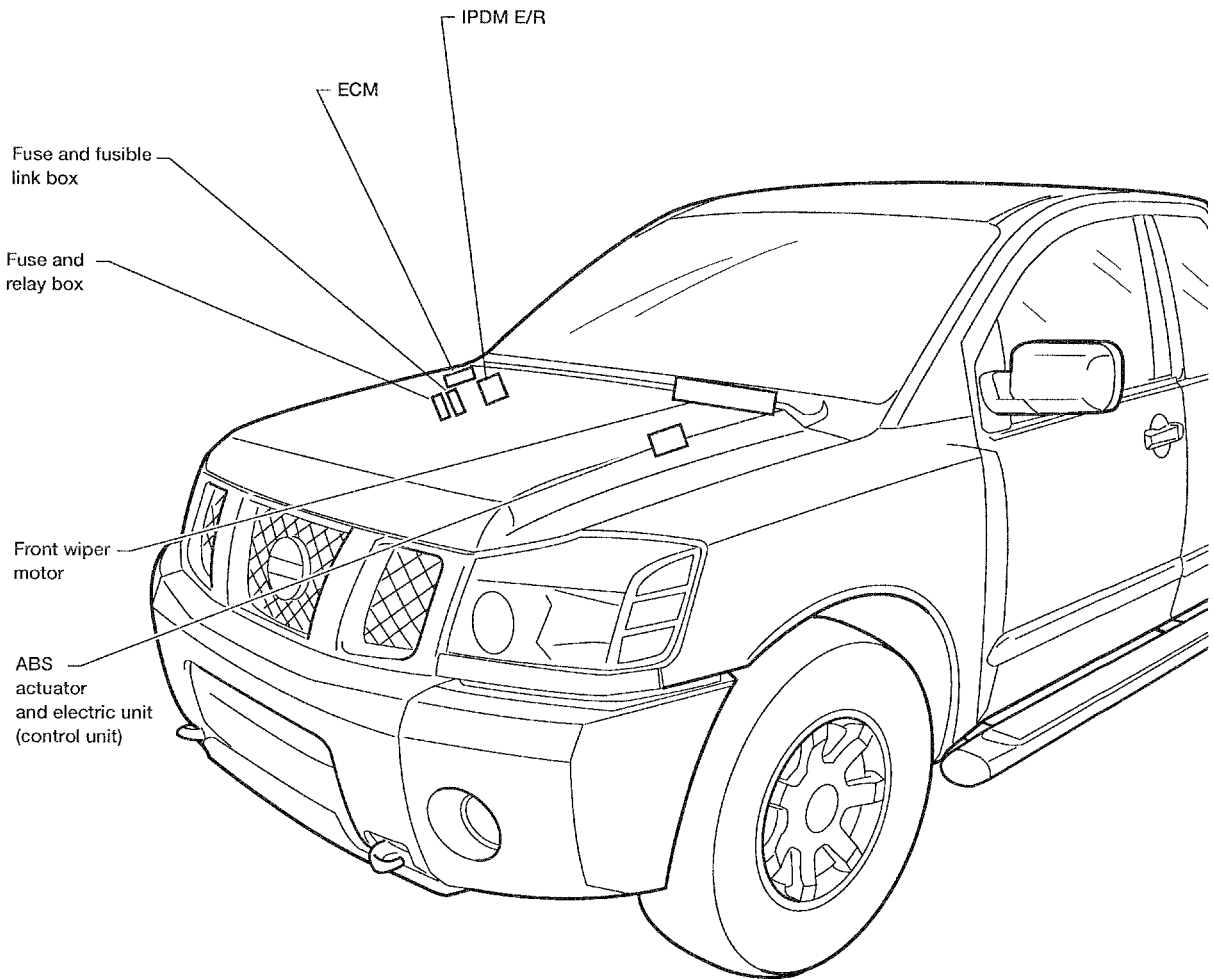

A

B

C

D

E

F

G

H

I

J

PG

L

M

ELECTRICAL UNITS LOCATION

PASSENGER COMPARTMENT

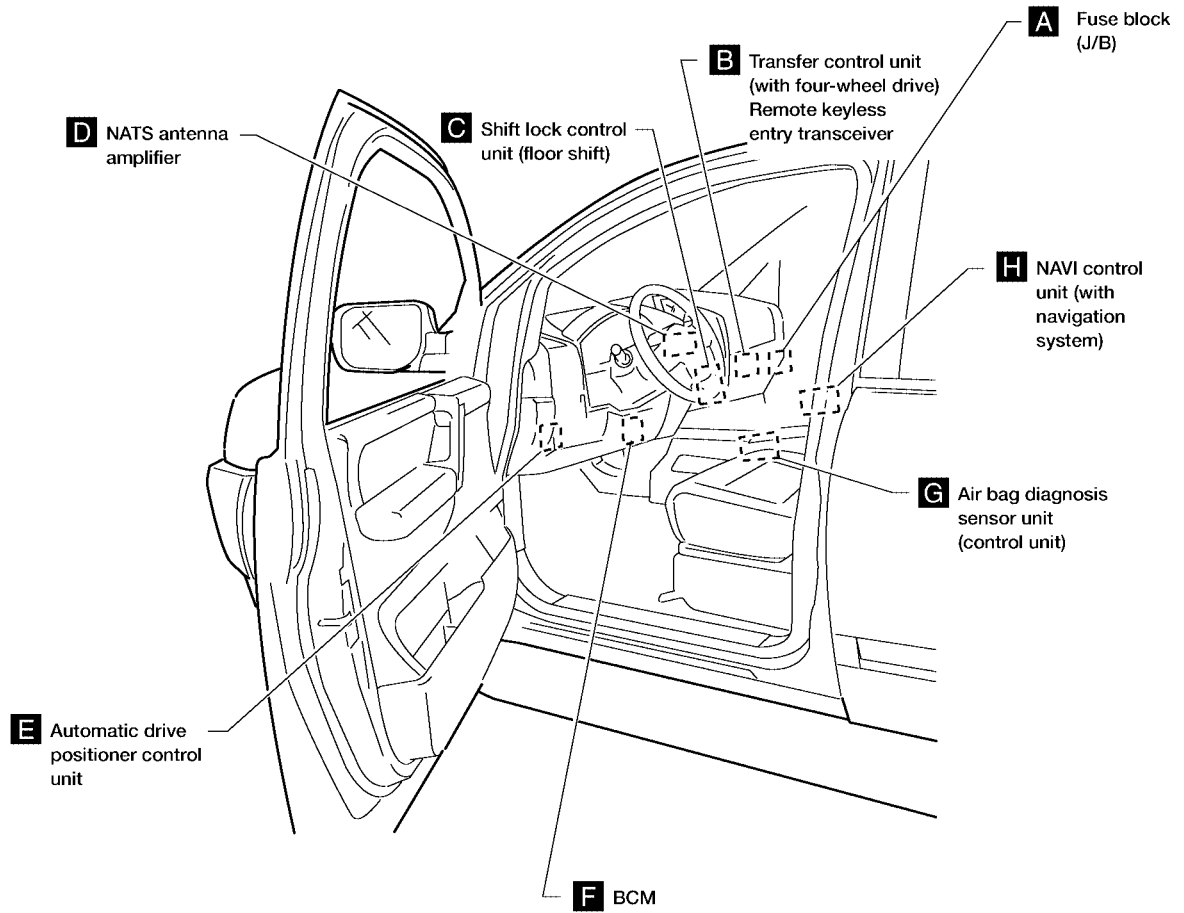

A Instrument panel side RH

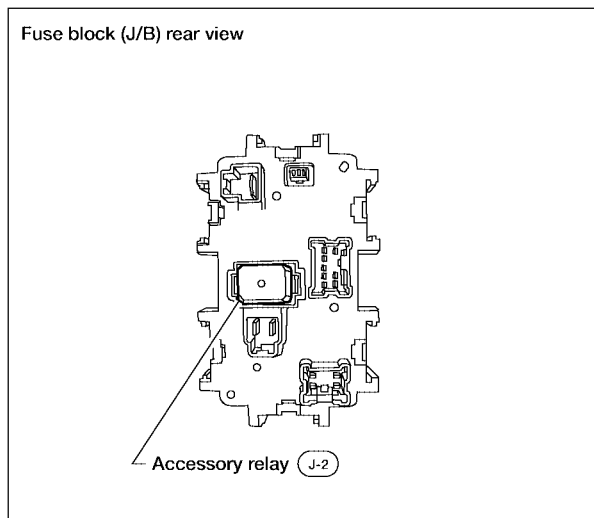
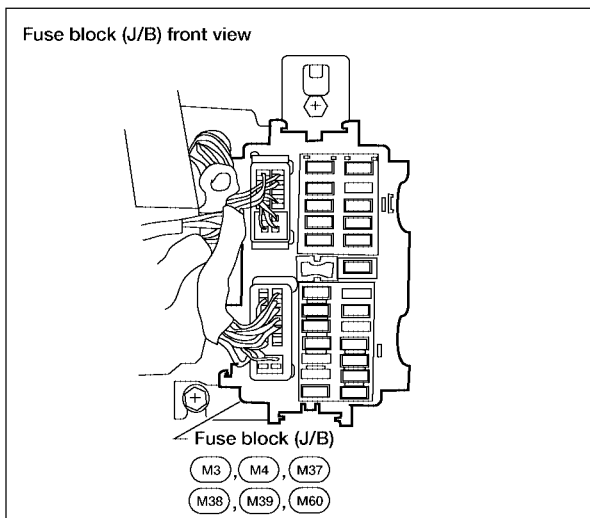

WKIA2872E

ELECTRICAL UNITS LOCATION

B View with instrument panel removed RH

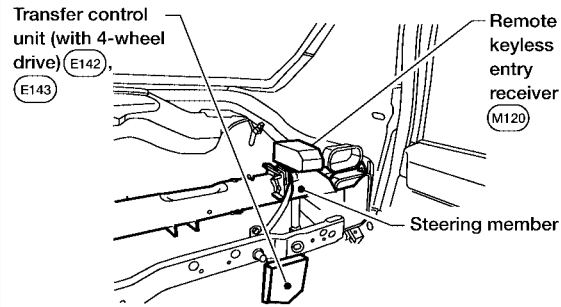

C View with instrument panel removed RH

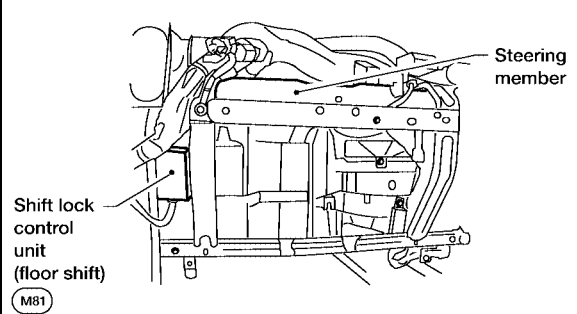

D View with lower driver instrument panel removed
NATS antenna amplifier (M21)

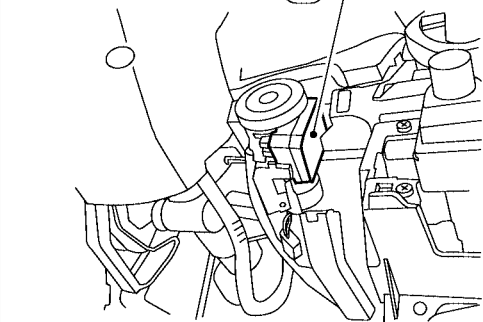

E View with steering member removed LH

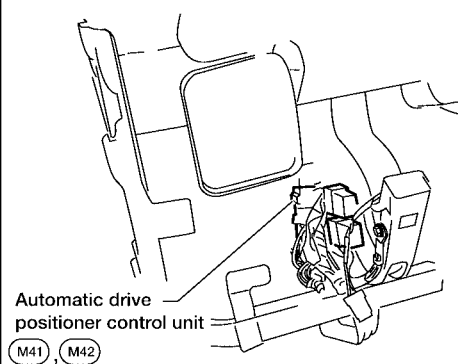

F View with instrument panel removed

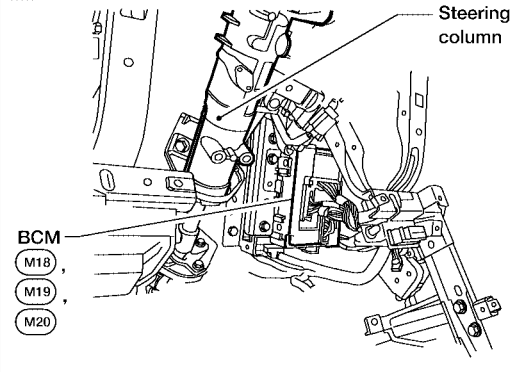

G View with center console removed

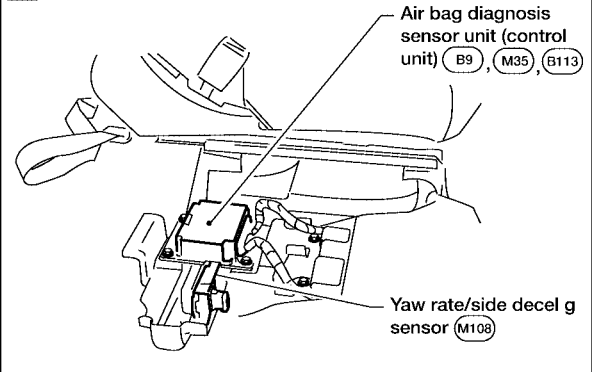

H View with passenger seat removed

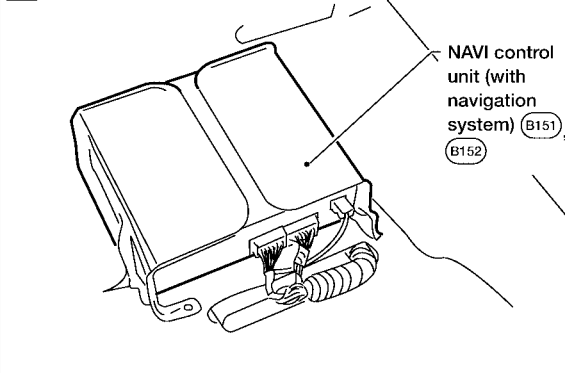

A
B
C
D
E
F
G
H
I
J
L
M

PG

WKIA1705E

ELECTRICAL UNITS LOCATION

Fuse

EKS00ARM

- If fuse is blown, be sure to eliminate cause of incident before installing new fuse.
- Use fuse of specified rating. Never use fuse of more than specified rating.
- Do not partially install fuse; always insert it into fuse holder properly.
- Remove fuse for "ELECTRICAL PARTS (BAT)" if vehicle is not used for a long period of time.

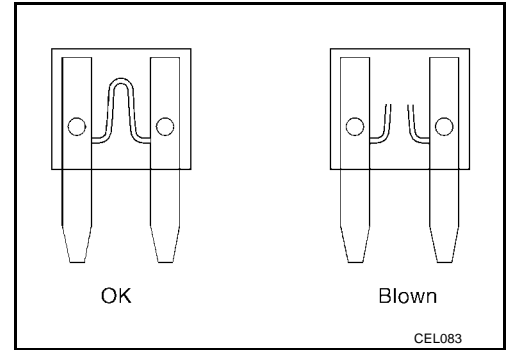

Fusible Link

EKS00ARO

A melted fusible link can be detected either by visual inspection or by feeling with finger tip. If its condition is questionable, use circuit tester or test lamp.

CAUTION:

- If fusible link should melt, it is possible that critical circuit (power supply or large current carrying circuit) is shorted. In such a case, carefully check and eliminate cause of incident.
- Never wrap outside of fusible link with vinyl tape.
- Never let fusible link touch any other wiring harness, vinyl or rubber parts.

Circuit Breaker (Built Into BCM)

EKS00ARO

For example, when current is 30A, the circuit is broken within 8 to 20 seconds.

A circuit breaker is used for the following systems:

- Power seat
- Power windows
- Power door locks
- Remote keyless entry system
- Power sunroof
- Rear window wiper

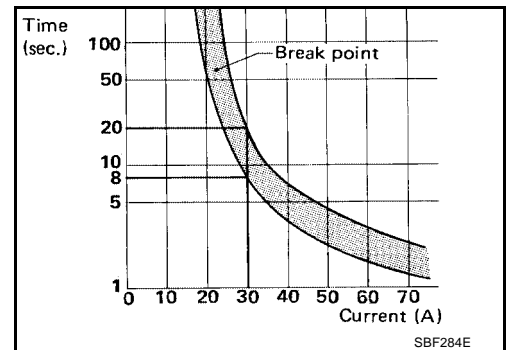

HARNESS CONNECTOR

PFP:B4341

EKS00ARP

HARNESS CONNECTOR

Description

HARNESS CONNECTOR (TAB-LOCKING TYPE)

- The tab-locking type connectors help prevent accidental looseness or disconnection.
- The tab-locking type connectors are disconnected by pushing or lifting the locking tab(s). Refer to the illustration below.

Refer to the next page for description of the slide-locking type connector.

CAUTION:

Do not pull the harness or wires when disconnecting the connector.

[Example]

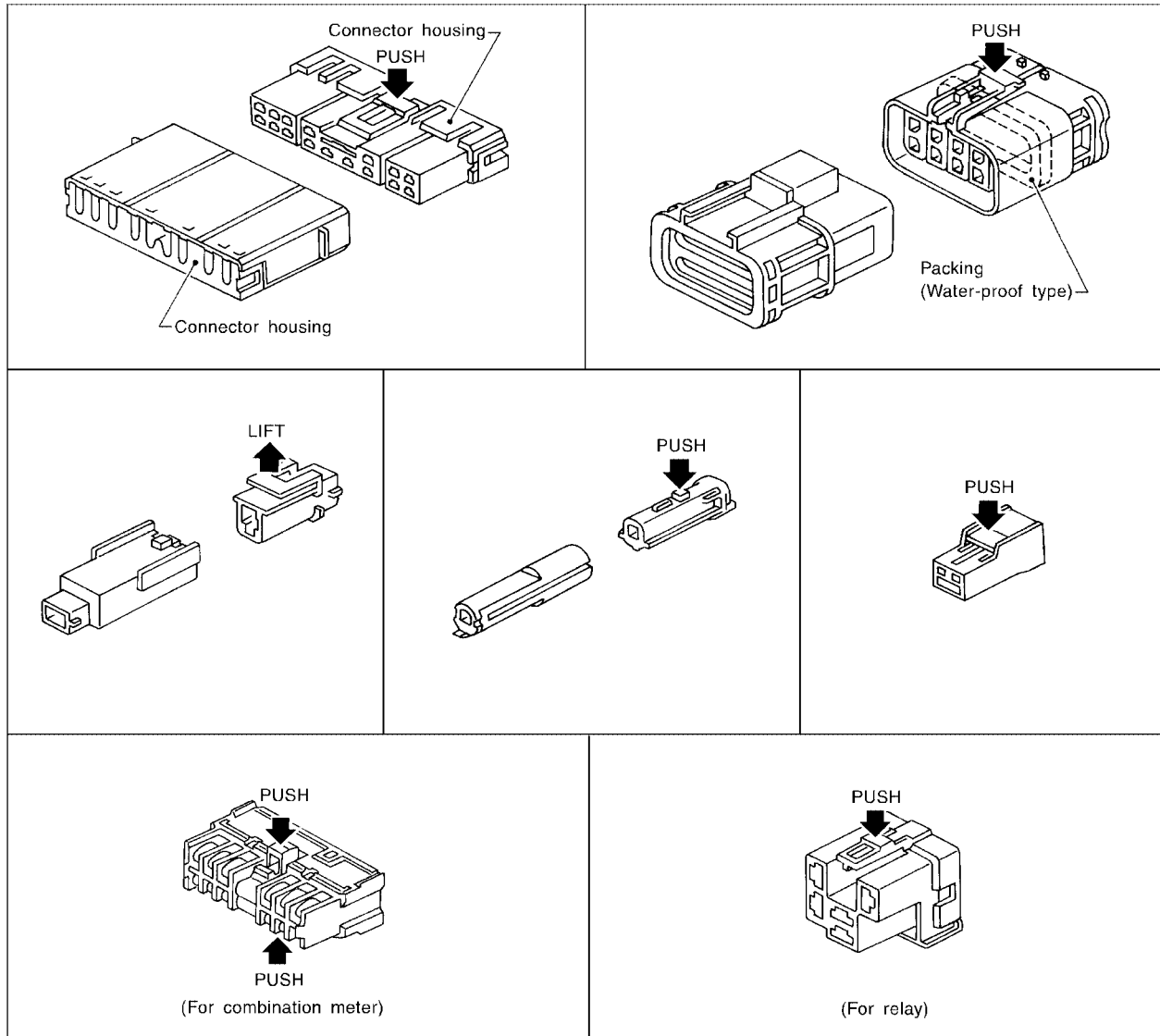

A
B
C
D
E
F
G
H
I
J
PG
L
M

HARNESS CONNECTOR

HARNESS CONNECTOR (SLIDE-LOCKING TYPE)

- A new style slide-locking type connector is used on certain systems and components, especially those related to OBD.
- The slide-locking type connectors help prevent incomplete locking and accidental looseness or disconnection.
- The slide-locking type connectors are disconnected by pushing or pulling the slider. Refer to the illustration below.

CAUTION:

- Do not pull the harness or wires when disconnecting the connector.
- Be careful not to damage the connector support bracket when disconnecting the connector.

[Example]

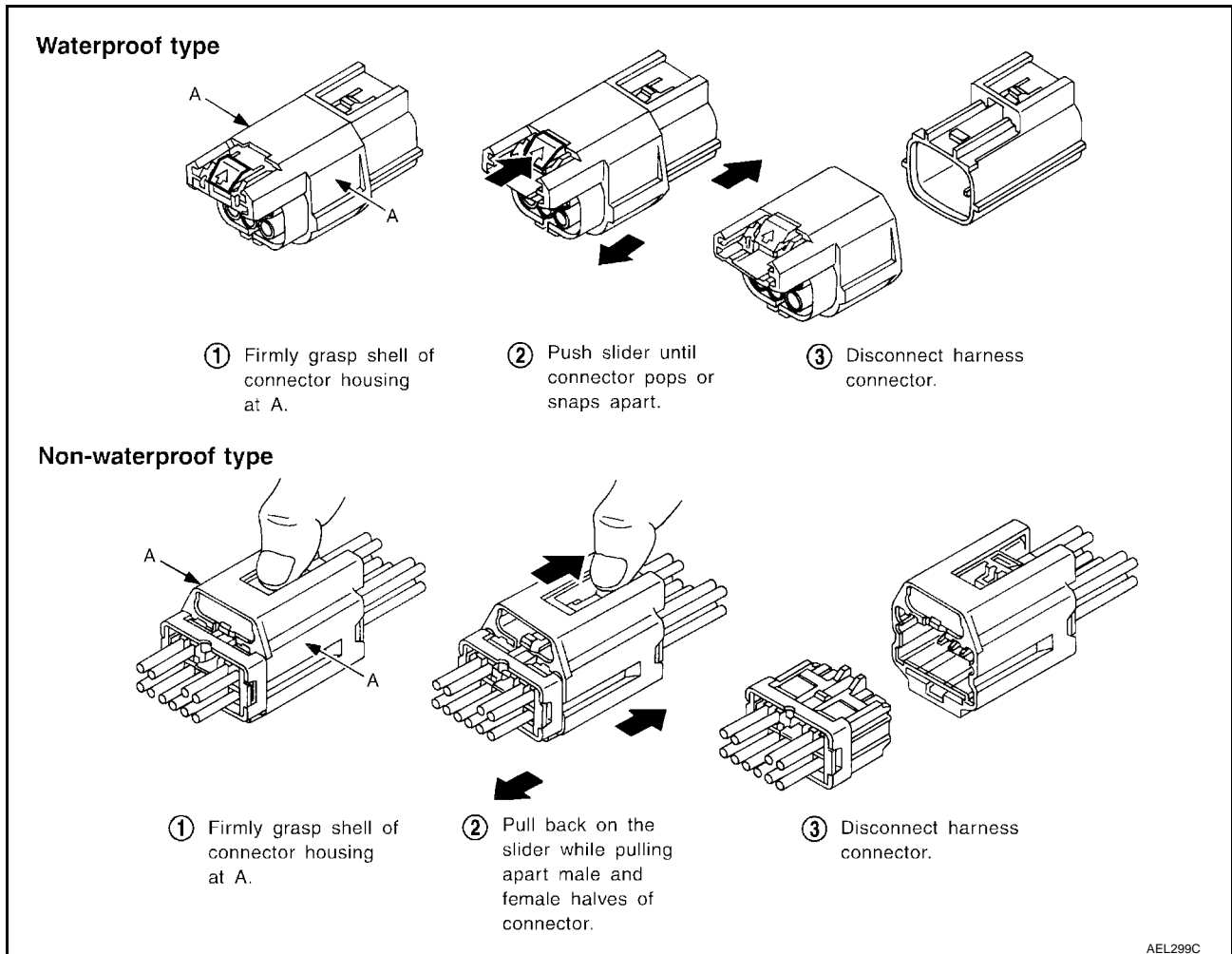

HARNESS CONNECTOR

HARNESS CONNECTOR (DIRECT-CONNECT SRS COMPONENT TYPE)

- SRS direct-connect type harness connectors are used on certain SRS components such as air bag modules and seat belt pre-tensioners.
- Always pull up to release black locking tab prior to removing connector from SRS component.
- Always push down to lock black locking tab after installing connector to SRS component. When locked, the black locking tab is level with the connector housing.

CAUTION:

- **Do not pull the harness or wires when removing connectors from SRS components.**

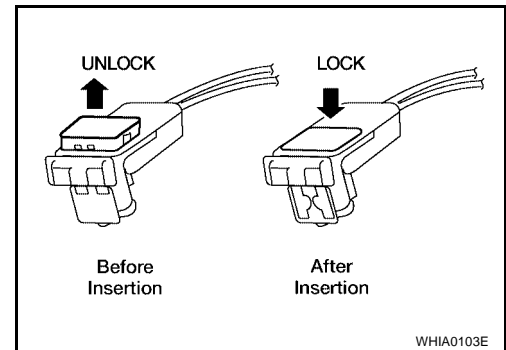

A

B

C

D

E

F

G

H

I

J

PG

L

M

ELECTRICAL UNITS

ELECTRICAL UNITS Terminal Arrangement

PF23710

EKS00AR0

BCM (BODY CONTROL MODULE)

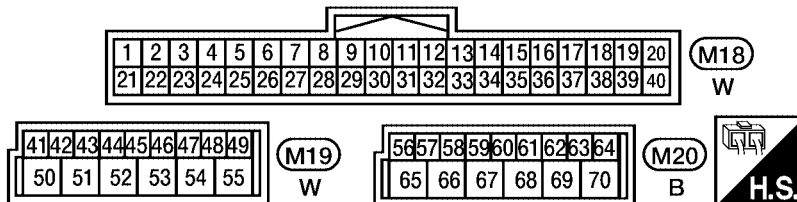

ABS ACTUATOR AND ELECTRIC UNIT (CONTROL UNIT)

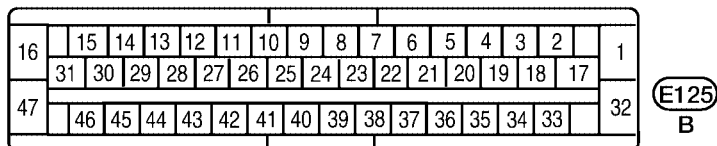

ECM

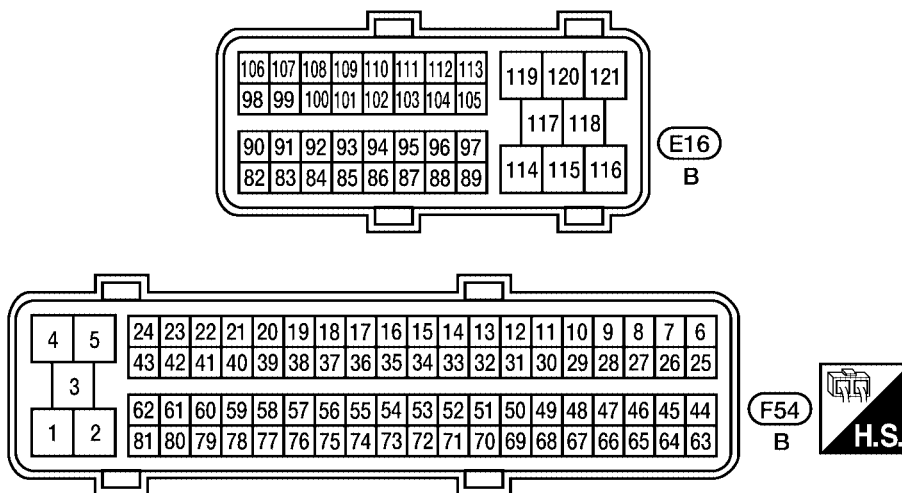

TRANSFER CONTROL UNIT

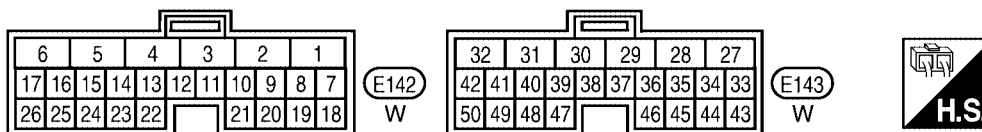

WKIA3648E

STANDARDIZED RELAY

PFP:25230

EKS00ARR

STANDARDIZED RELAY

Description

NORMAL OPEN, NORMAL CLOSED AND MIXED TYPE RELAYS

Relays can mainly be divided into three types: normal open, normal closed and mixed type relays.

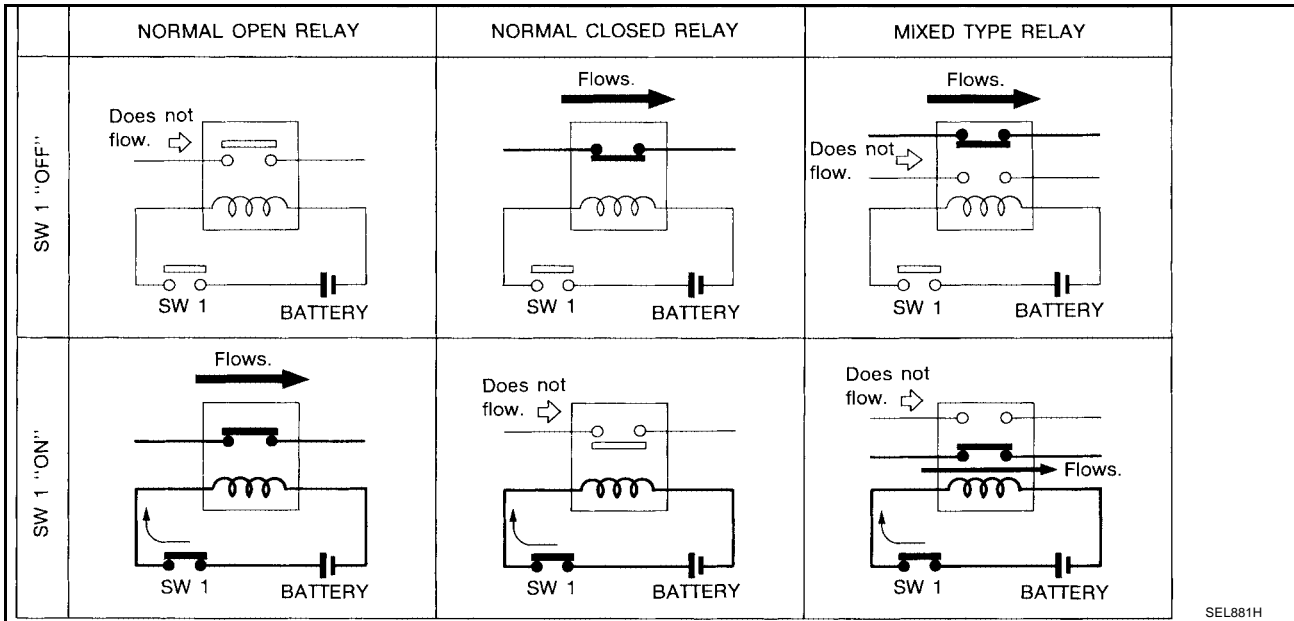

TYPE OF STANDARDIZED RELAYS

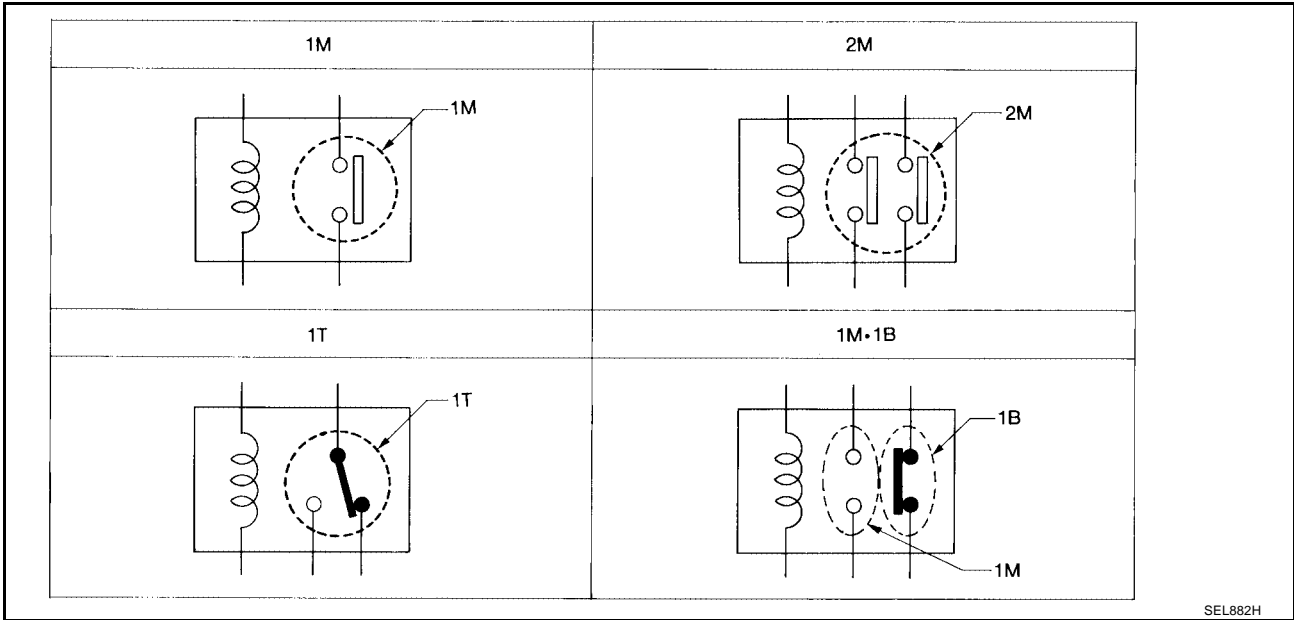

1M	1 Make	2M	2 Make
1T	1 Transfer	1M-1B	1 Make 1 Break

STANDARDIZED RELAY

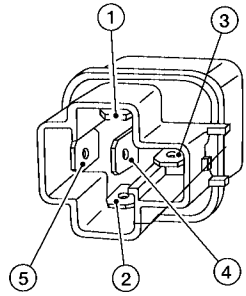
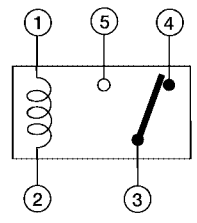
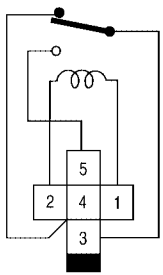
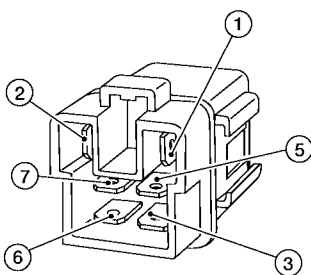
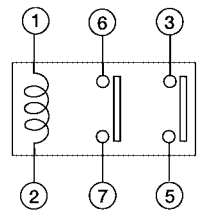
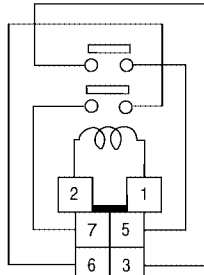
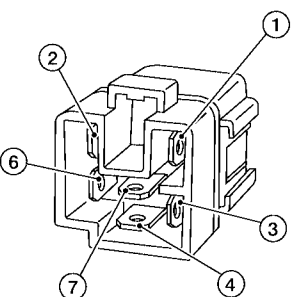
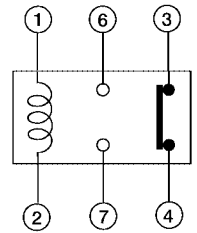
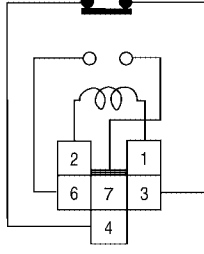
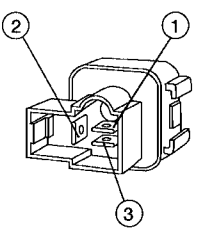
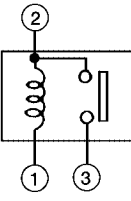
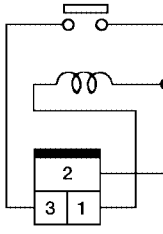
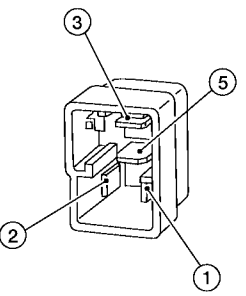
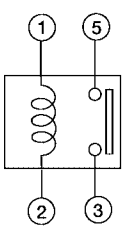
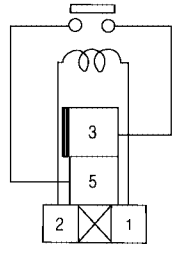
Type	Outer view	Circuit	Connector Symbol and connection	Case color
1T				BLACK
2M				BROWN
1M-1B				GRAY
1M				BLACK
				BLUE

The arrangement of terminal numbers on the actual relays may differ from those shown above.

WKIA0253E

SUPER MULTIPLE JUNCTION (SMJ)

SUPER MULTIPLE JUNCTION (SMJ)

PF:84341

Terminal Arrangement

EKS00ARS

A
B
C
D
E
F
G
H
I
J
PG
L
M

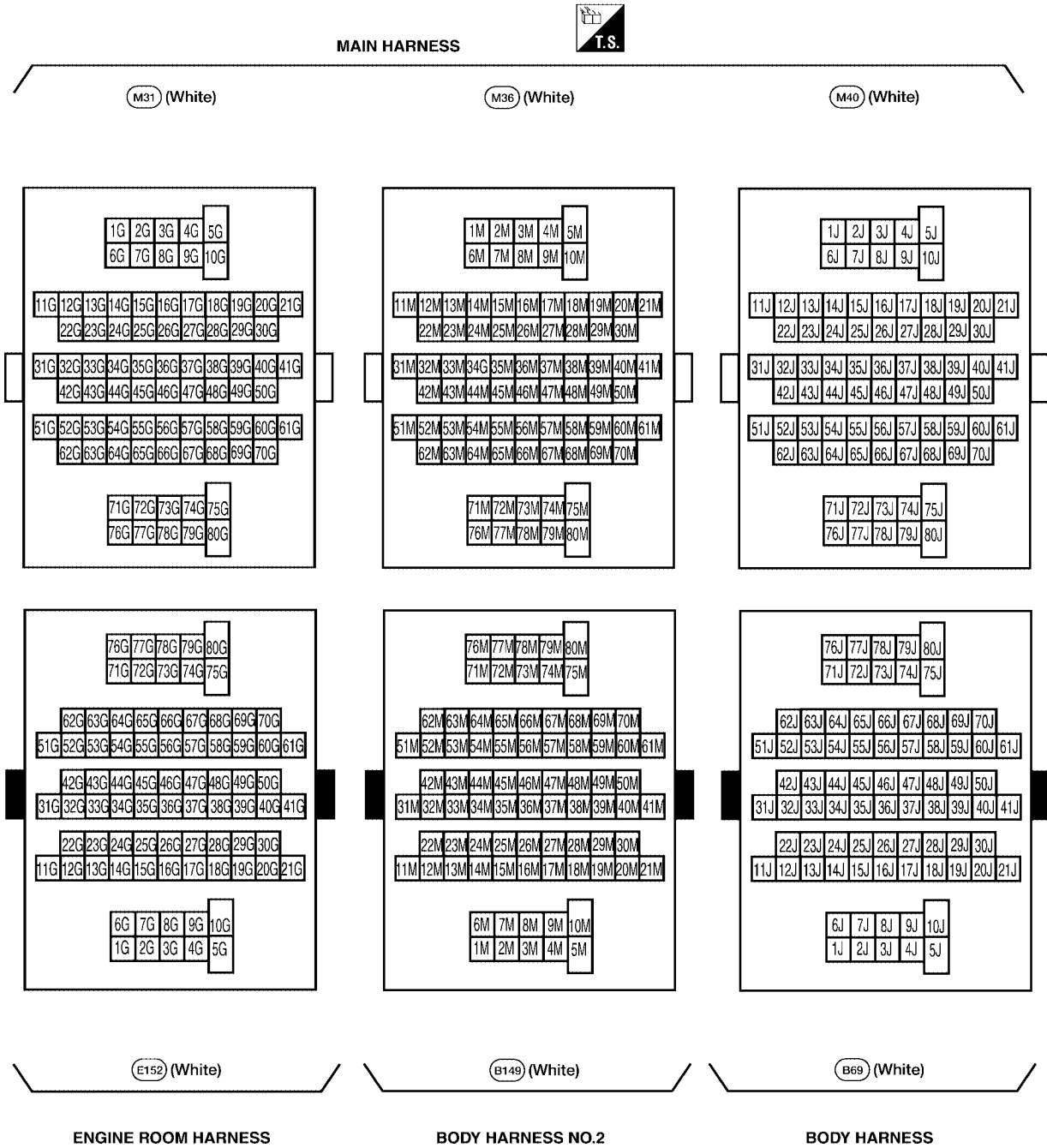

SUPER MULTIPLE JUNCTION (SMJ)

CHASSIS HARNESS



(C1) (Gray)

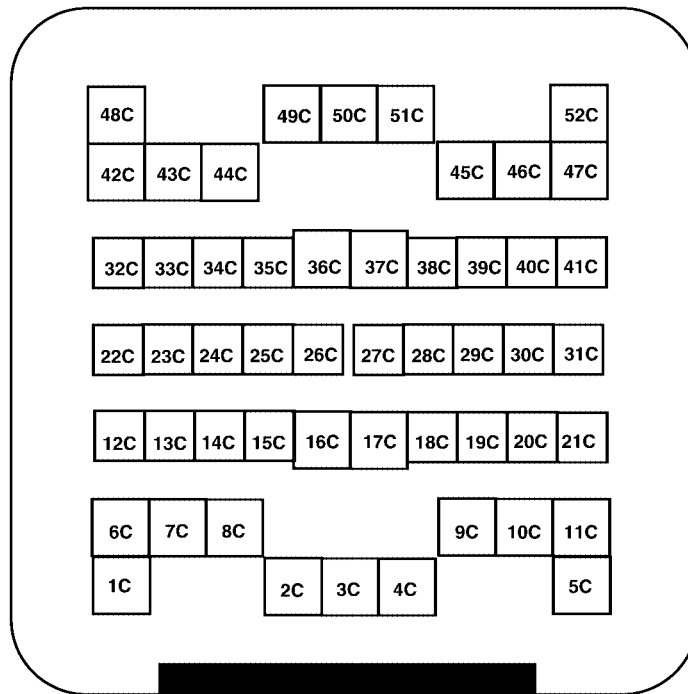
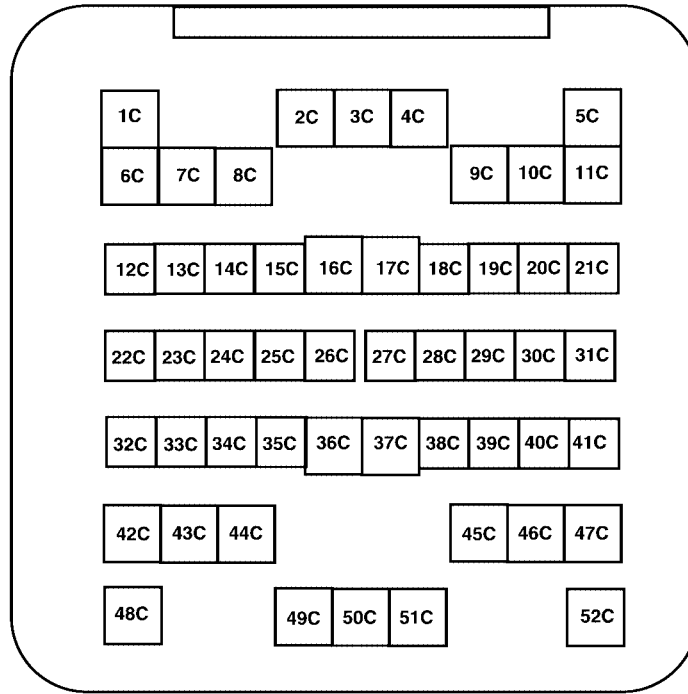

(E41) (Gray)

ENGINE ROOM HARNESS

WKIA1845E

FUSE BLOCK-JUNCTION BOX(J/B)

PF24350

EKS00ART

FUSE BLOCK-JUNCTION BOX(J/B) Terminal Arrangement

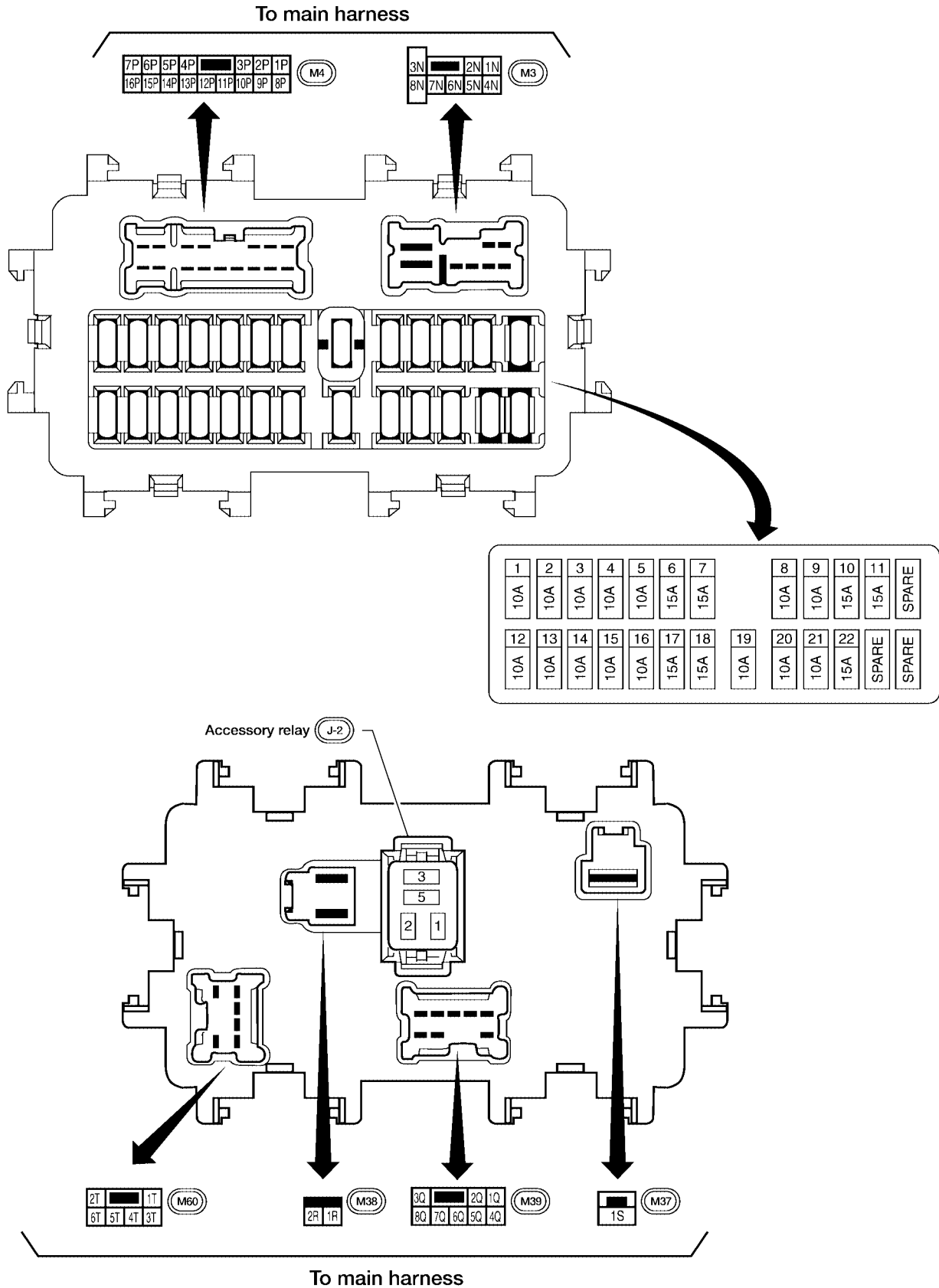

A
B
C
D
E
F
G
H
I
J
PG
L
M

FUSE AND FUSIBLE LINK BOX

FUSE AND FUSIBLE LINK BOX

PF24381

Terminal Arrangement

EKS00ARU

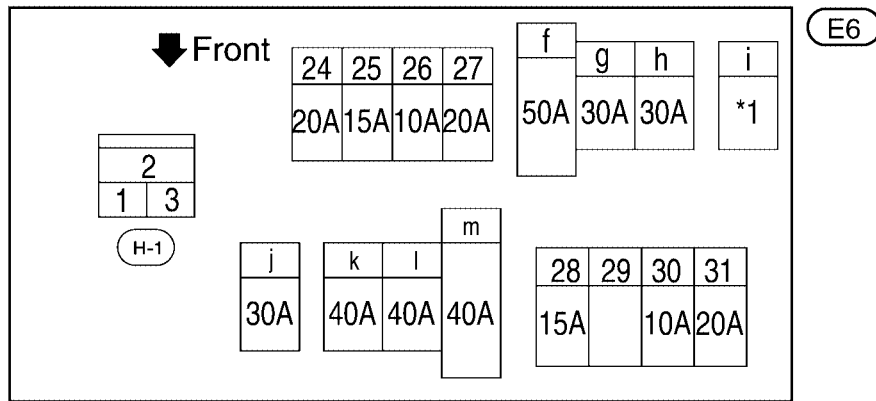

24 - 31: FUSE f - m: FUSIBLE LINK

*1 40A with VDC
30A without VDC

FUSE AND RELAY BOX

PF24012

EKS00ARV

FUSE AND RELAY BOX Terminal Arrangement

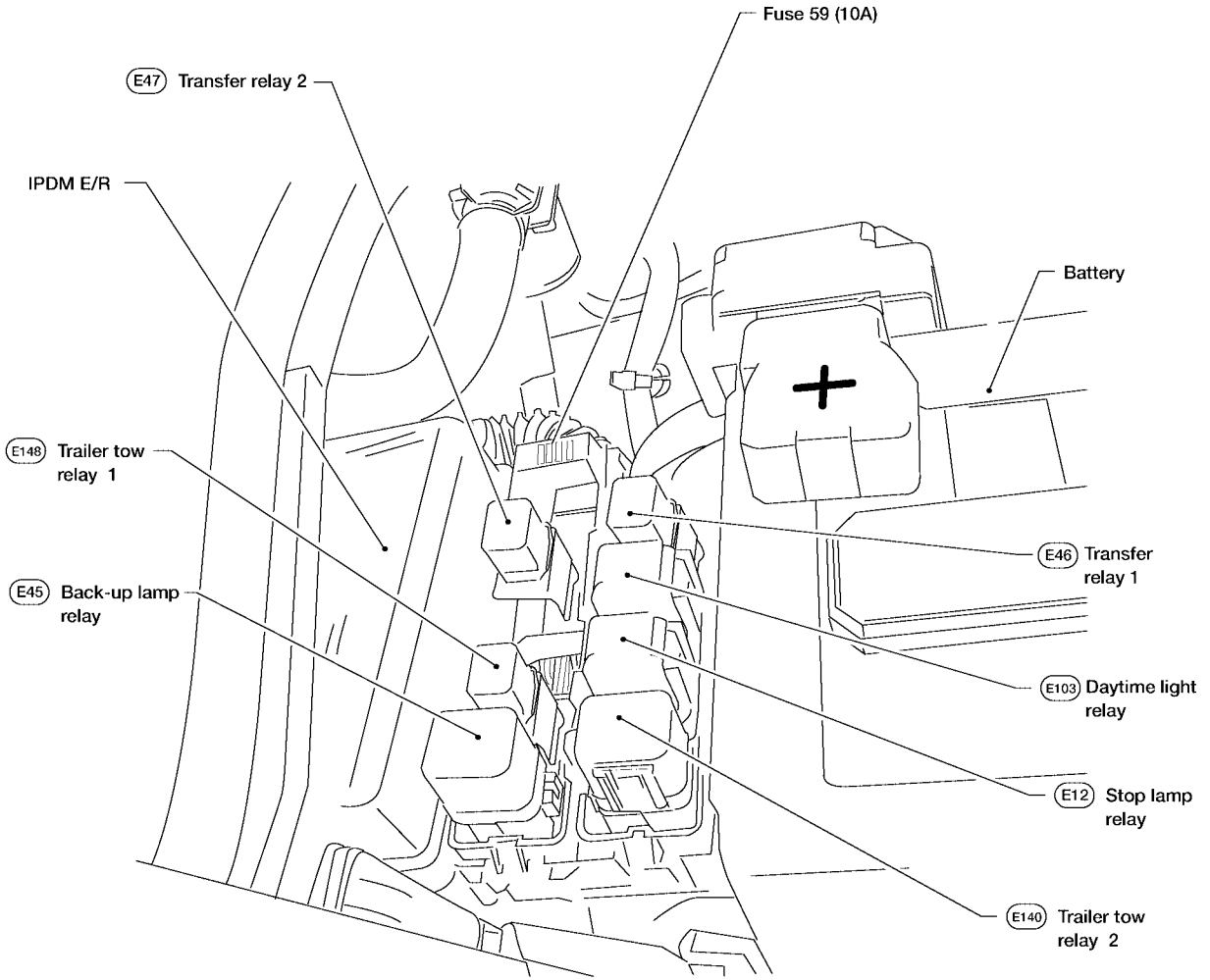

A
B
C
D
E
F
G
H
I
J
PG
L
M

WKIA2870E

FUSE AND RELAY BOX
